

## Classic Glider Bench

Please check contents before assembly. If any items are missing or damaged, **do not take the unit back to the store.** Please call customer service and we will save you time by correcting any problems.

### CARE INSTRUCTIONS

The Glider Bench has been conditioned for outdoor use with an oil-based color stain. To maintain the beauty and life expectancy of the chair, it is highly recommended that you treat the chair with weather proof coating (teak oil stain or weatherproof coating) once a year.

- Cover the Bench during harsh weather to keep it from weathering.
- Rinse any panels with water to clean.
- When assembling this furniture, please handle all panels and/or hardware with care to avoid any possibilities of damages and/or injuries.

#### COMPONENTS

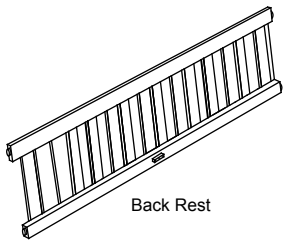

Back Rest

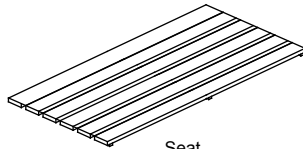

Seat

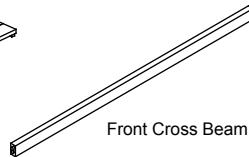

Front Cross Beam

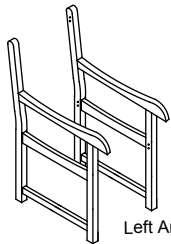

Left Arm Rest

Right Arm Rest

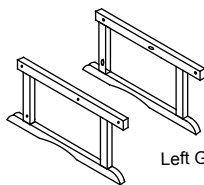

Left Glider Leg

Right Glider Leg



Glider Brackets

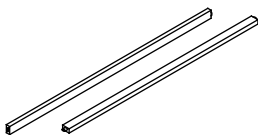

Glider Back Cross Beams

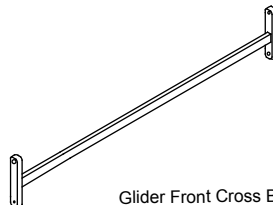

Glider Front Cross Beam

#### HARDWARE

- ① Screw x 10 Pcs (M7x60)mm
- ② Bolt x 8 Pcs (M6x20)mm
- ③ Washers x 8 Pcs
- ④ Locking Bolts x 8 Pcs
- ⑤ Screws x 2 Pcs (M4 x 30)mm
- ⑥ Allen Key x 2 Pcs

**NOTE:** Read all instructions before starting.

**Do not completely tighten any bolts until the unit is fully assembled and sitting on a level surface.**

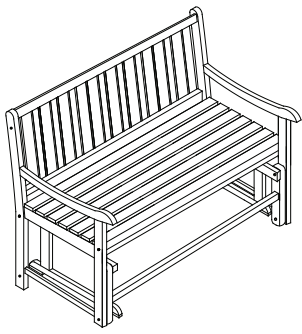

### Classic Glider Bench

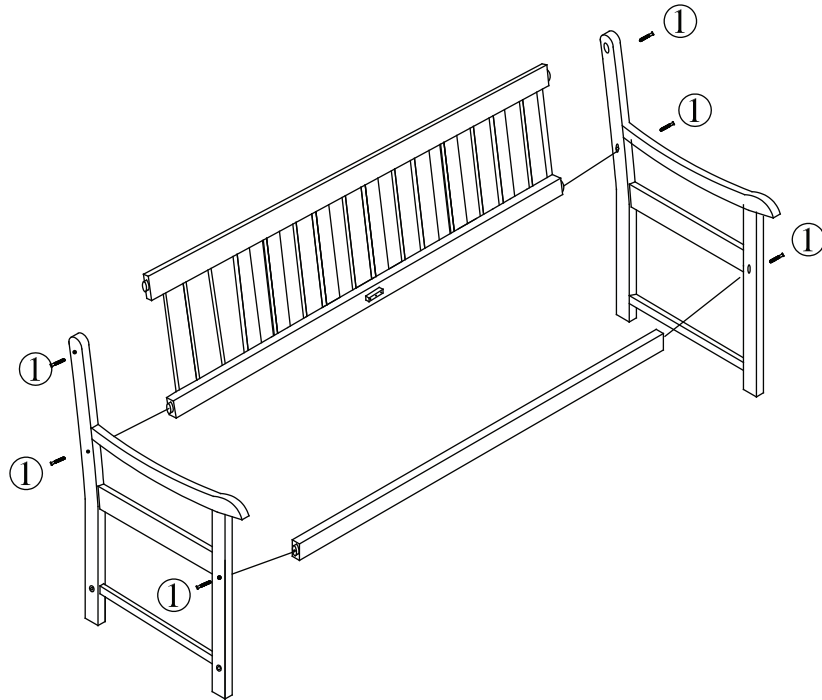

**Step 1:** Insert dowelled ends of Back Rest and Front Cross Beam into Left and Right Arm Rests. Secure with Screws (1) using appropriate Allen Key (6).

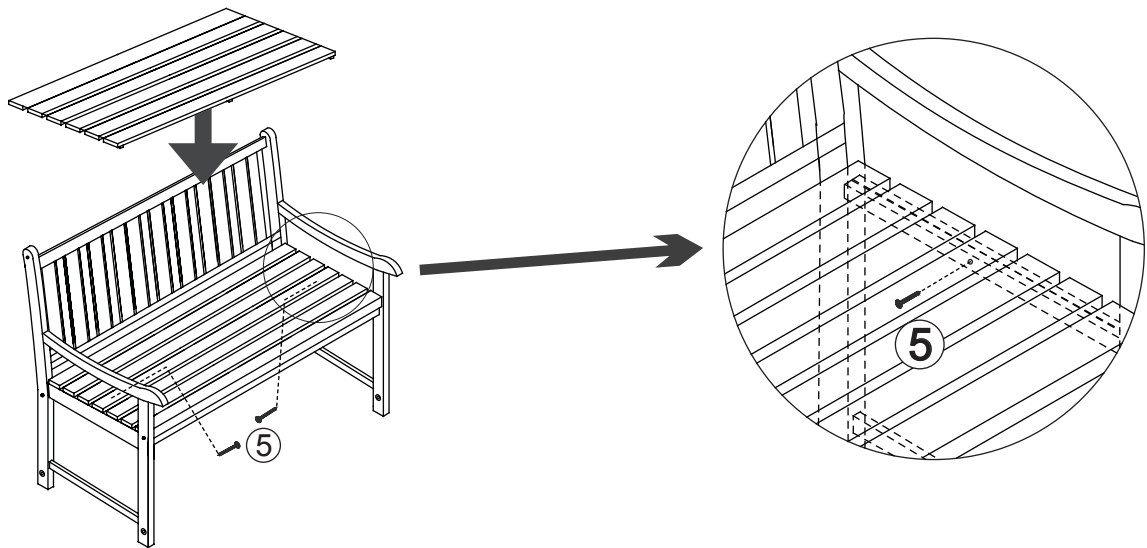

**Step 2:** Insert Seat into place. Secure with 2 Screws (5) underneath the seat using a Phillips Screwdriver.

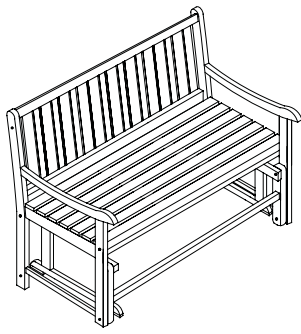

### Classic Glider Bench

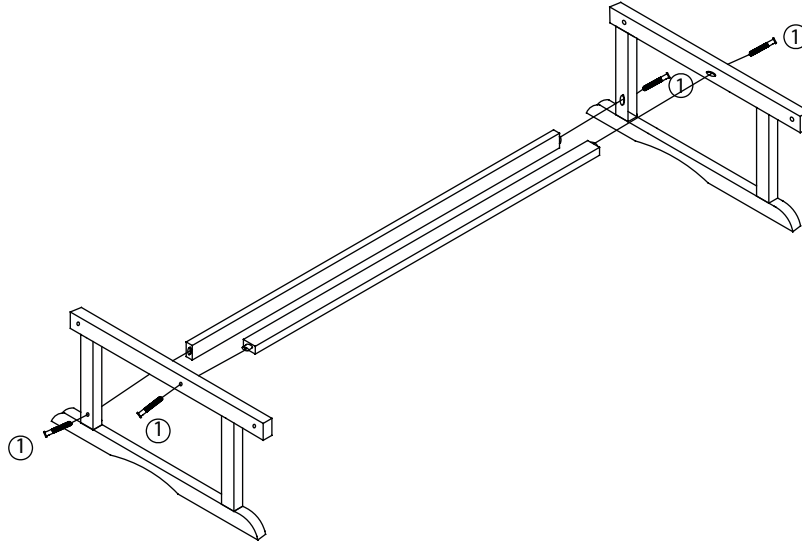

**Step 3:** Assemble Glider Back Cross Beams to Right and Left Glider Legs. Secure with 4 Screws (1) using appropriate Allen Key (5).

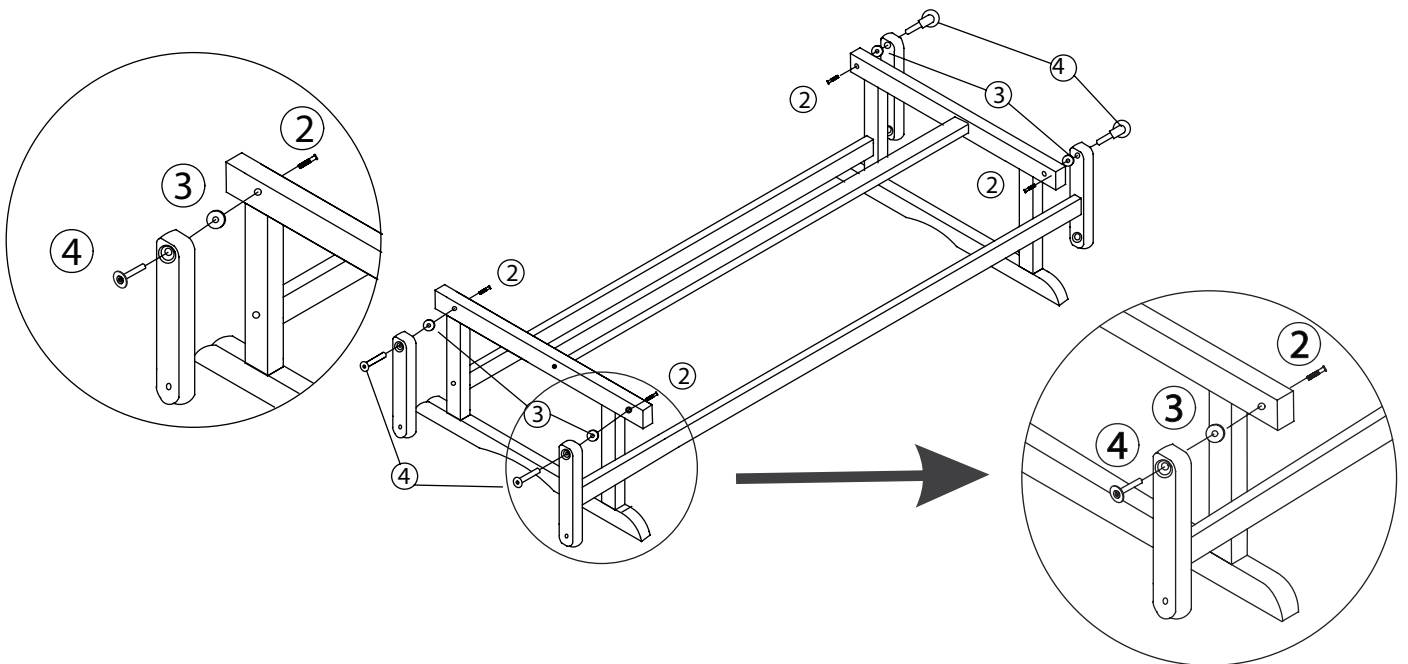

**Step 4:** Assemble Glider Brackets and Glider Front Cross Beam to Glider Legs. Secure with Bolt (2), Washer (3) and Locking Bolt (4) using appropriate Allen Key (6). Please reference highlighted area for the correct location of the Bolts, Washers and Locking Bolts to complete this step.

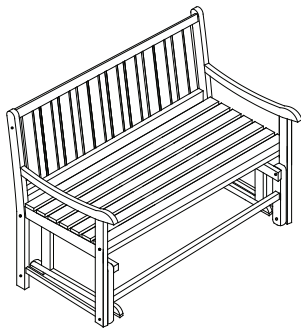

### Classic Glider Bench

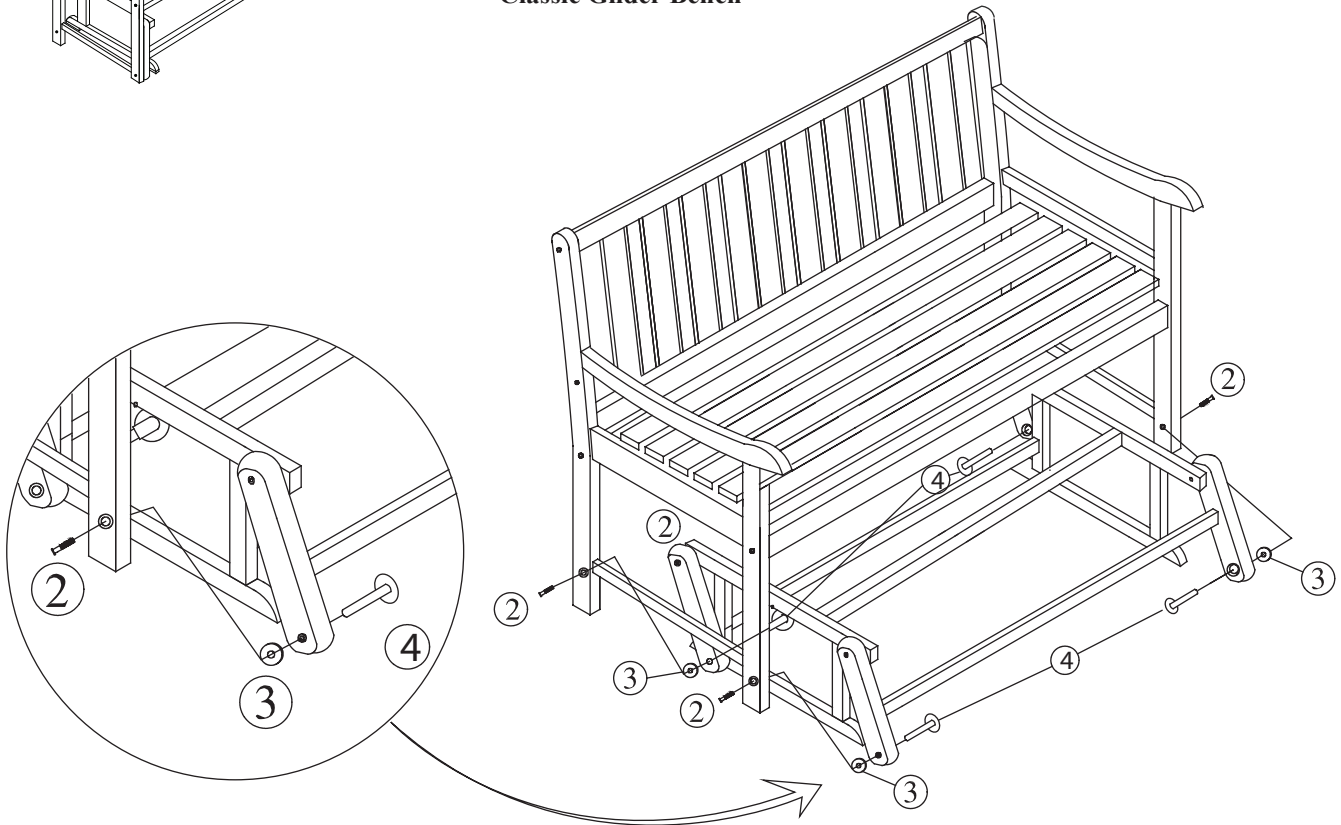

**Step 4:** Place the completed Bench portion over the Glider portion. Secure the Glider Brackets to the legs of the Bench using Bolt (2), Washer (3) and Locking Bolt (4) at each leg. Please reference the highlighted area for correct placement of hardware at each leg.

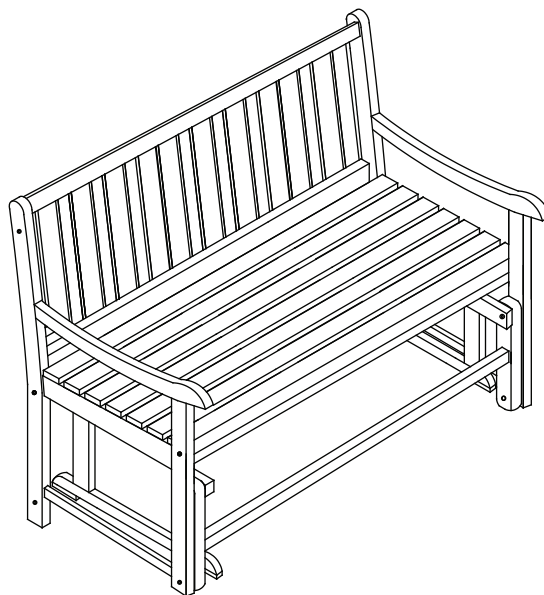

**Step 5:** Tighten all Screws (1) and Bolts (2) using appropriate Allen Keys (6) to complete assembly.