

ASSEMBLY INSTRUCTION

A Chair Back **B** Seat Frame **C** Left Supporter **D** Right Supporter



1 pc



1 pc



1 pc



1 pc

E Front Leg **F** Seat **G** Pan Head Bolt 1/4", 5/8" **H** Lock Washer



2 pcs



1 pc



8 pcs



8 pcs

I Flat Washer **J** Flat Head Bolt 1/4", 1" **K** Wood Screw M5, 3/4" **L** Allen Wrench



8 pcs



6 pcs



3 pcs



1 pc

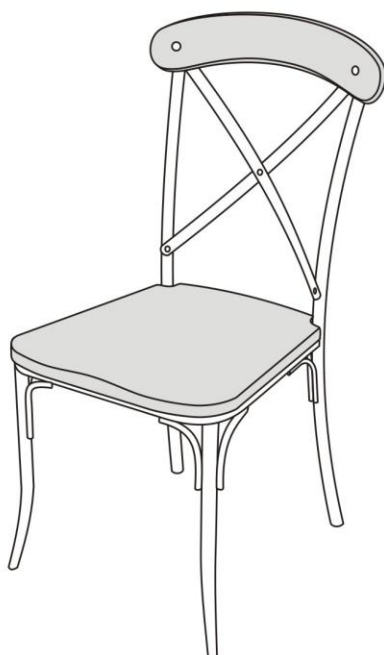

This page lists all the contents included in the box. Please take the time to identify the hardware as well as the individual components to this product. As you unpack and prepare for assembly, place the contents on a carpeted or padded area to protect them from damage.

1 Attach Seat Frame (B) to the Chair Back (A), insert Pan Head Bolt (G), Lock Washer (H), Flat Washer (I), and Allen Wrench (L).

2 Align the Left Supporter (C) and Right Supporter (D) to the Seat Frame (B), and Chair Back (A), assemble with Pan Head Bolt (G), Lock Washer (H), Flat Washer (I) and Allen Wrench (L).

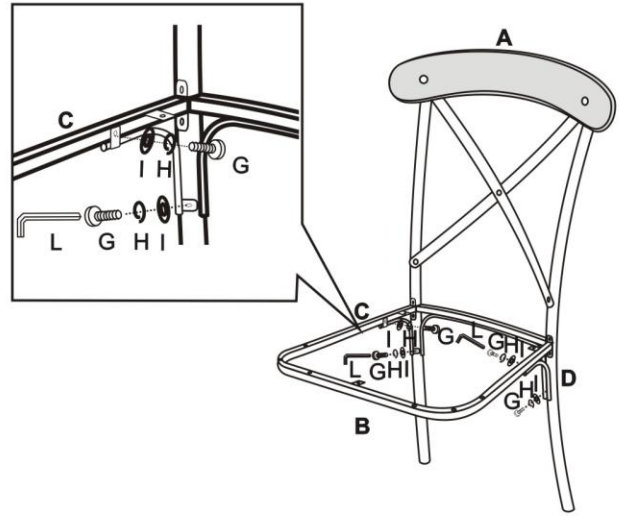
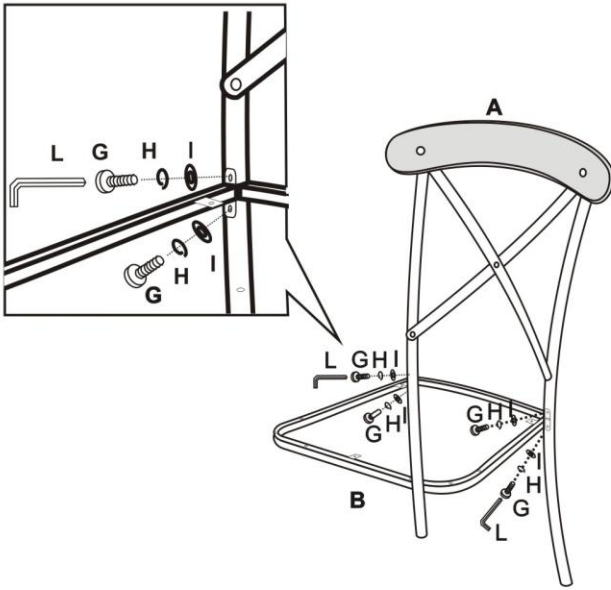

3 Attach Front Leg (E) to the Seat Frame (B), insert Flat Head Bolt (J) and tighten with Allen Wrench (L). Then tighten all bolts using Allen Wrench (L).

4 Attach the Seat (F) to the Seat Frame (B) and tighten with Wood Screw (K).

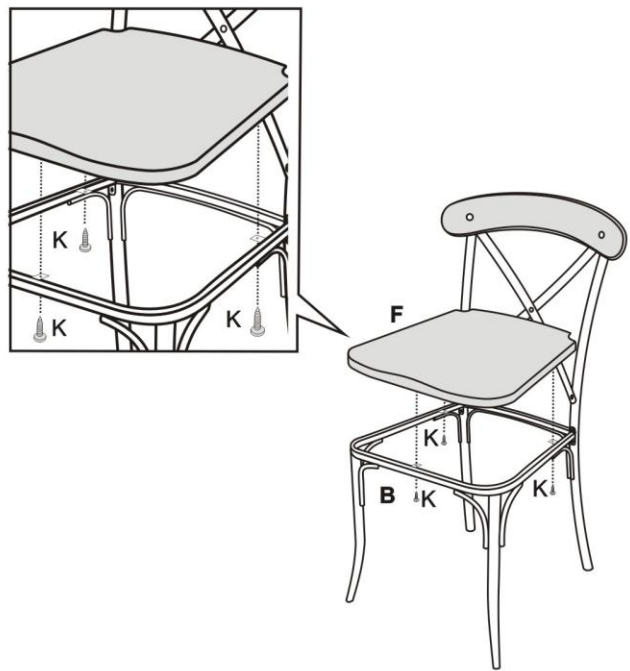
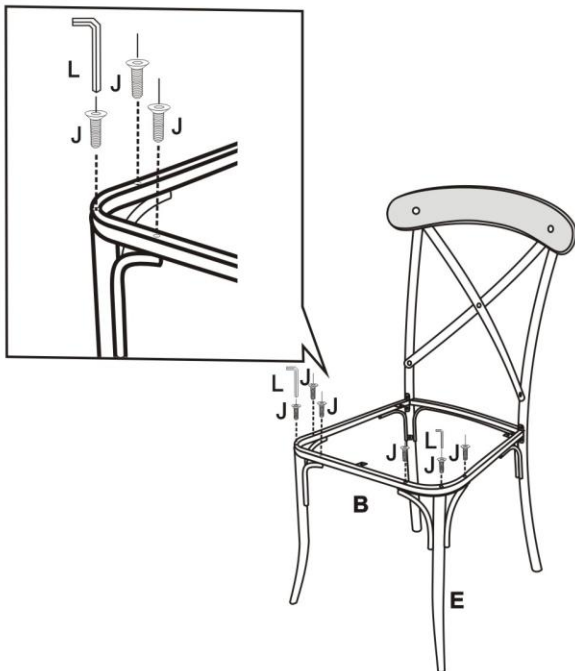

Cleaning & Care

Treat surface with care. Surface is resistant to scratches but is not scratch resistant. Clean surfaces with a dry or damp soft cloth. Do not use abrasive cleaners. Hardware may loosen over time. Periodically check that all connections are tight.