

Product installation Manual



Notice:

1. Rated voltage 110V, 50Hz, light source power $\leq 40W$
2. When installation should avoid scratching the surface of the lamp and wires. please must wear gloves.
3. The red wire of the lamps, should be connected to the live wire, variegated wire to neutral wire, the wire with Mark "PE" to the earth wire.
4. Do not install on the ceiling which failed to dry. The environment should be ventilated dry.
5. The Lamps shall not be close to the acid, alkali containing corrosive chemical substances and gases; Shall not be washed with water, only wipe with a clean soft cloth.
6. Must be installed by professional electrician.
7. Before installing, cleaning and replacing the bulbs, please turn off the power.

Step One:

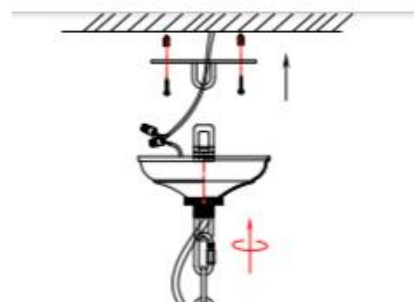

① put the plain washers on the self tapping screw, then tapping screws pass through the hanging plate hole and clockwise fasten, (as shown in the picture)

Step Two:

① Connect the input line and make sure insulation protection, (as shown in the picture)
② Fix the lamp body with hanging plate screws (as shown in the picture)

Step Three:



① Place the lampshade into the hardware plate.

② Lock the screw on the hardware plate to fix the lampshade