

Lift Top Coffee Table

Instruction Manual

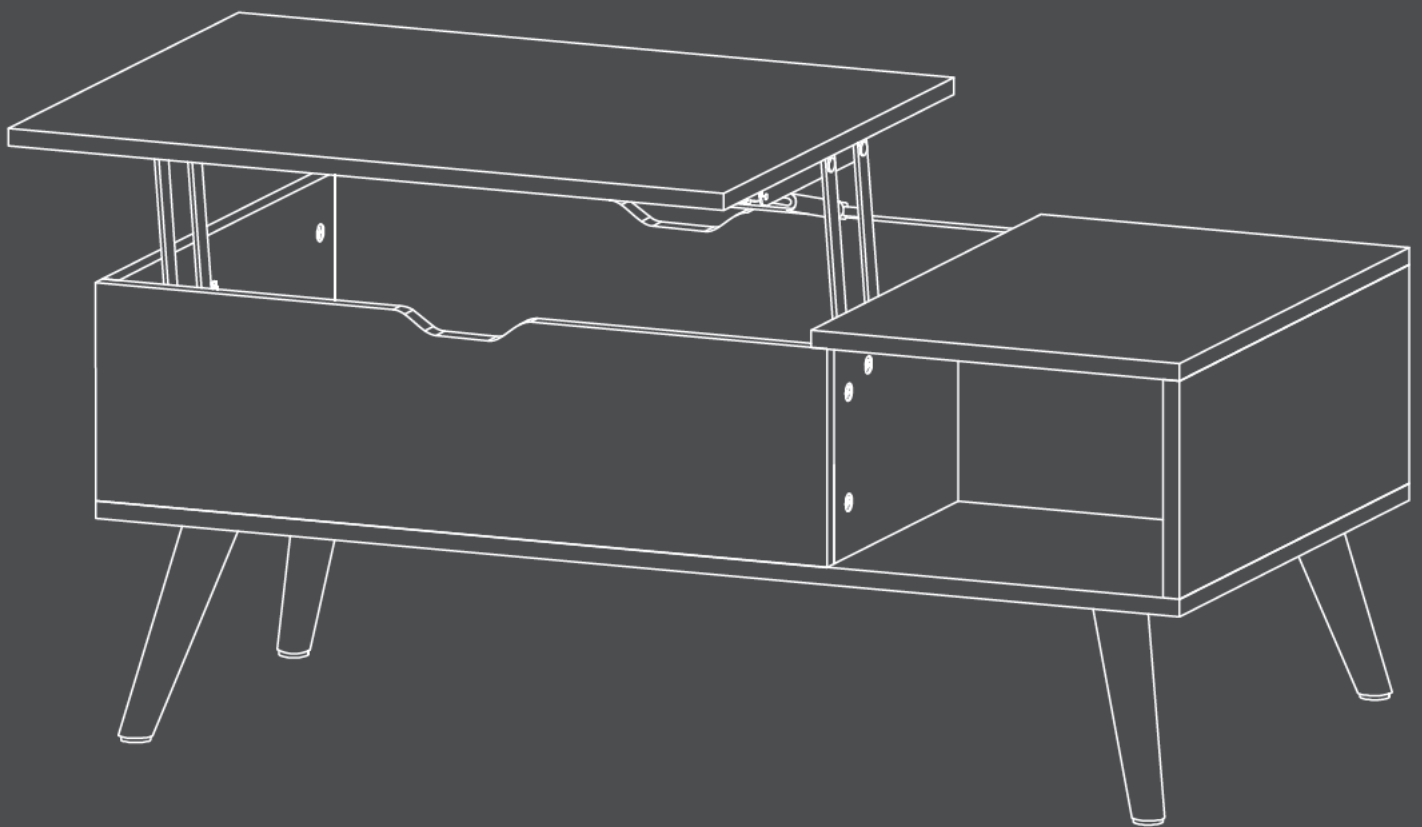

1 Component List

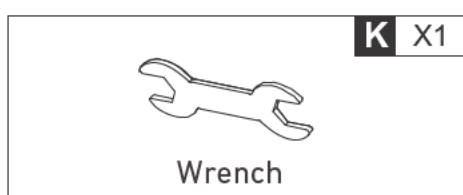
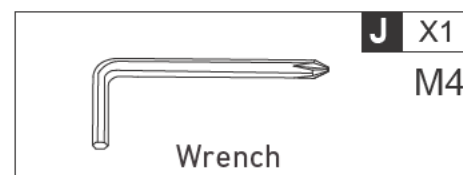
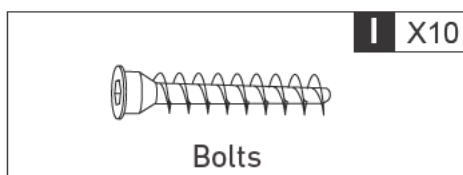
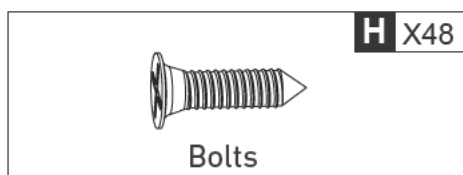
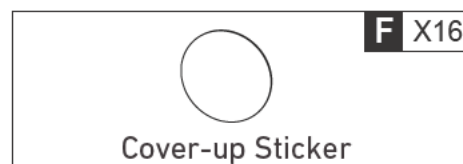
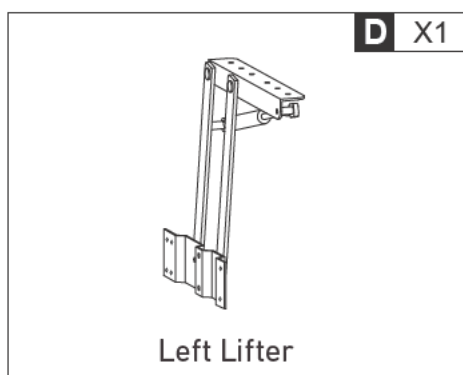
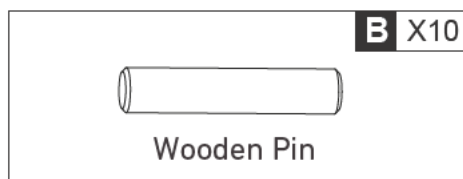
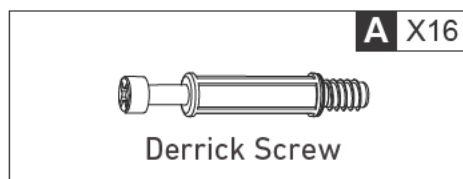
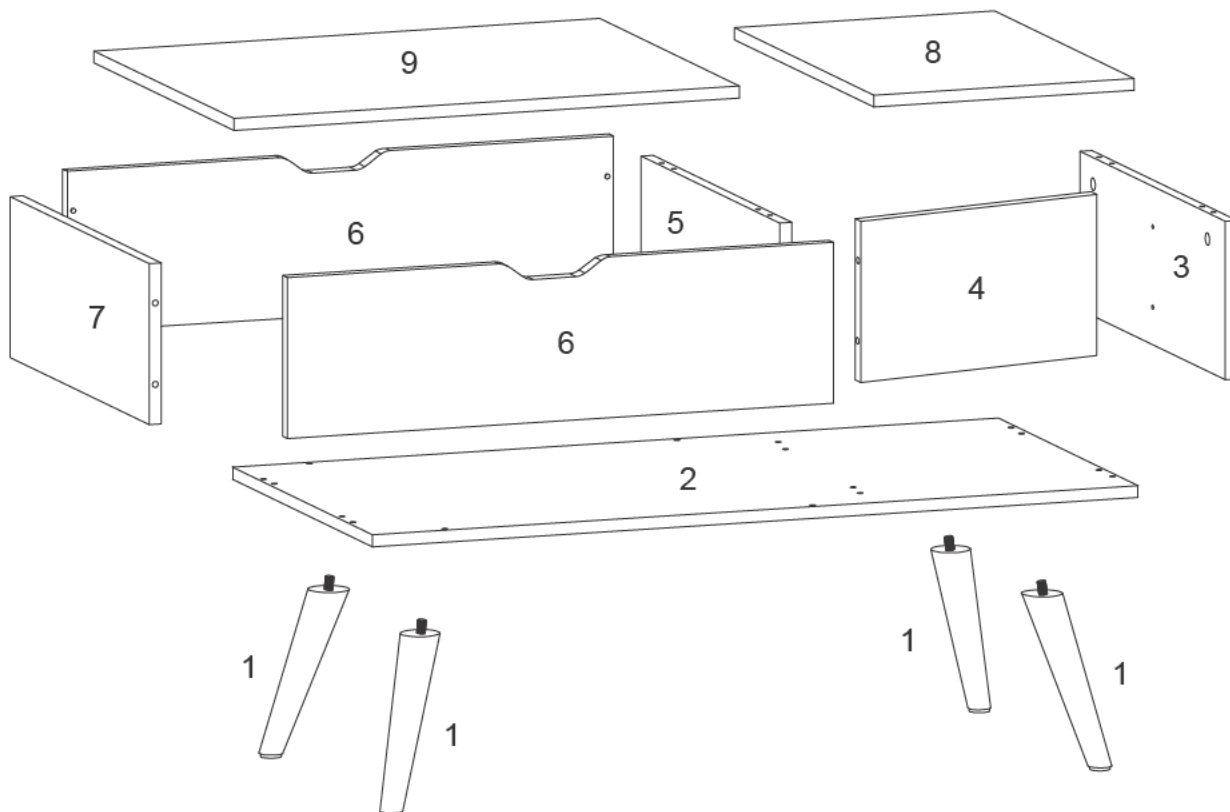

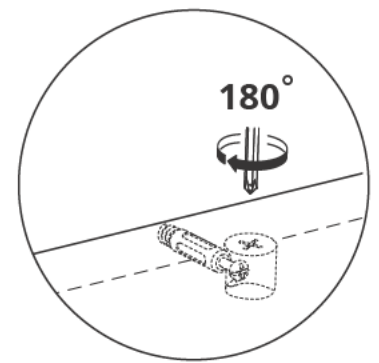
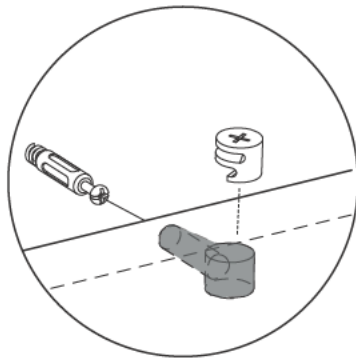
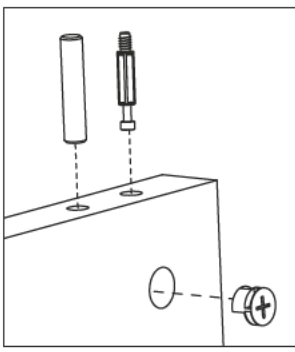

NOTE:

1. As shown, make sure each part is in the correct position.
2. Make sure the gap of the Eccentric Wheel is aligned with the Derrick Screw, and then tighten it completely.

Step 1

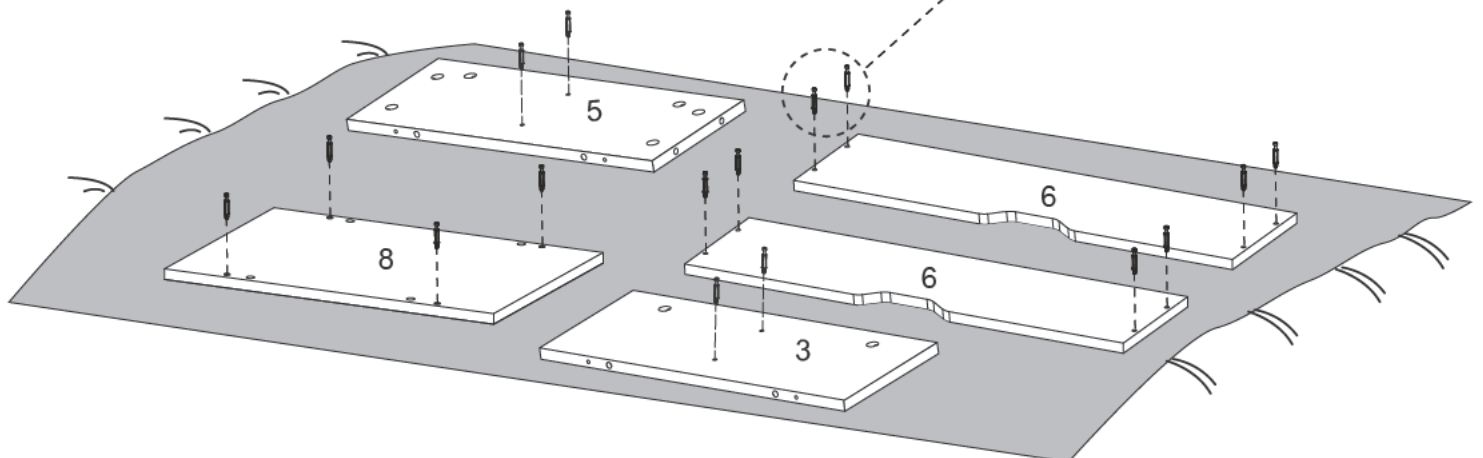
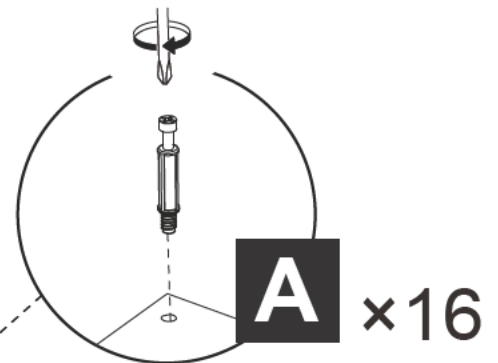
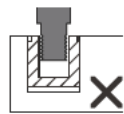
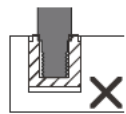
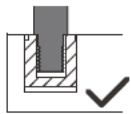
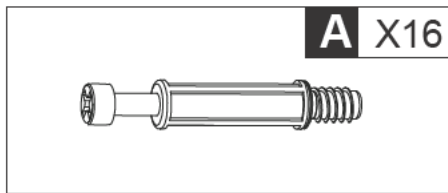

Fix Derrick Screw (A)*16 to Board (3), (5), (6)*2, (8) as shown.

NOTE:

1. Put a blanket under the board to avoid scratch or damage.
2. Please do not screw Derrick Screw (A) too deep or too shallow.

Step 2

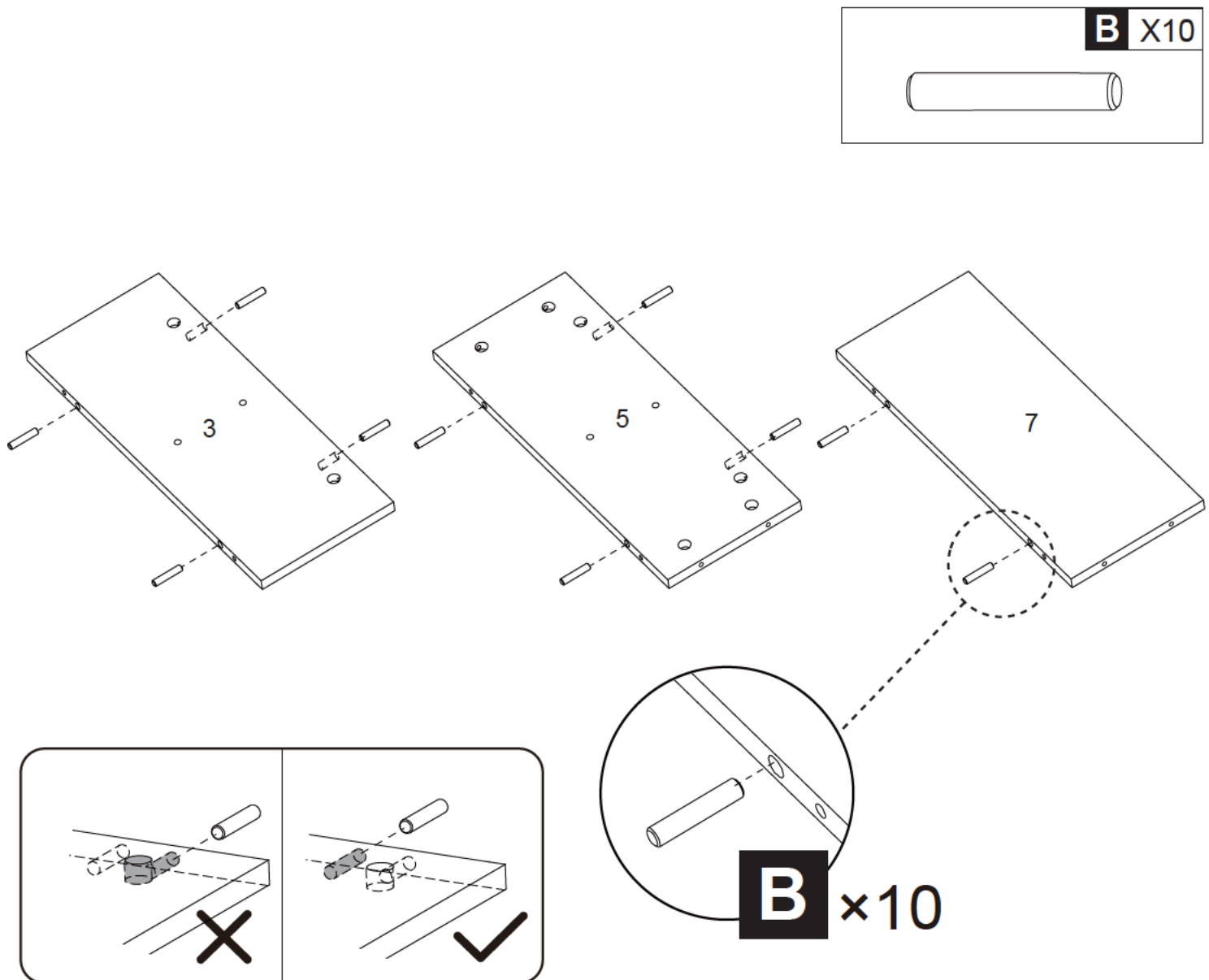

Attach Wooden Pin (**B**)*10 to Board (**3**), (**5**) and (**7**).

NOTE:

Install Wooden Pin (**B**) into the inner holes, not the outer holes.

Step 3

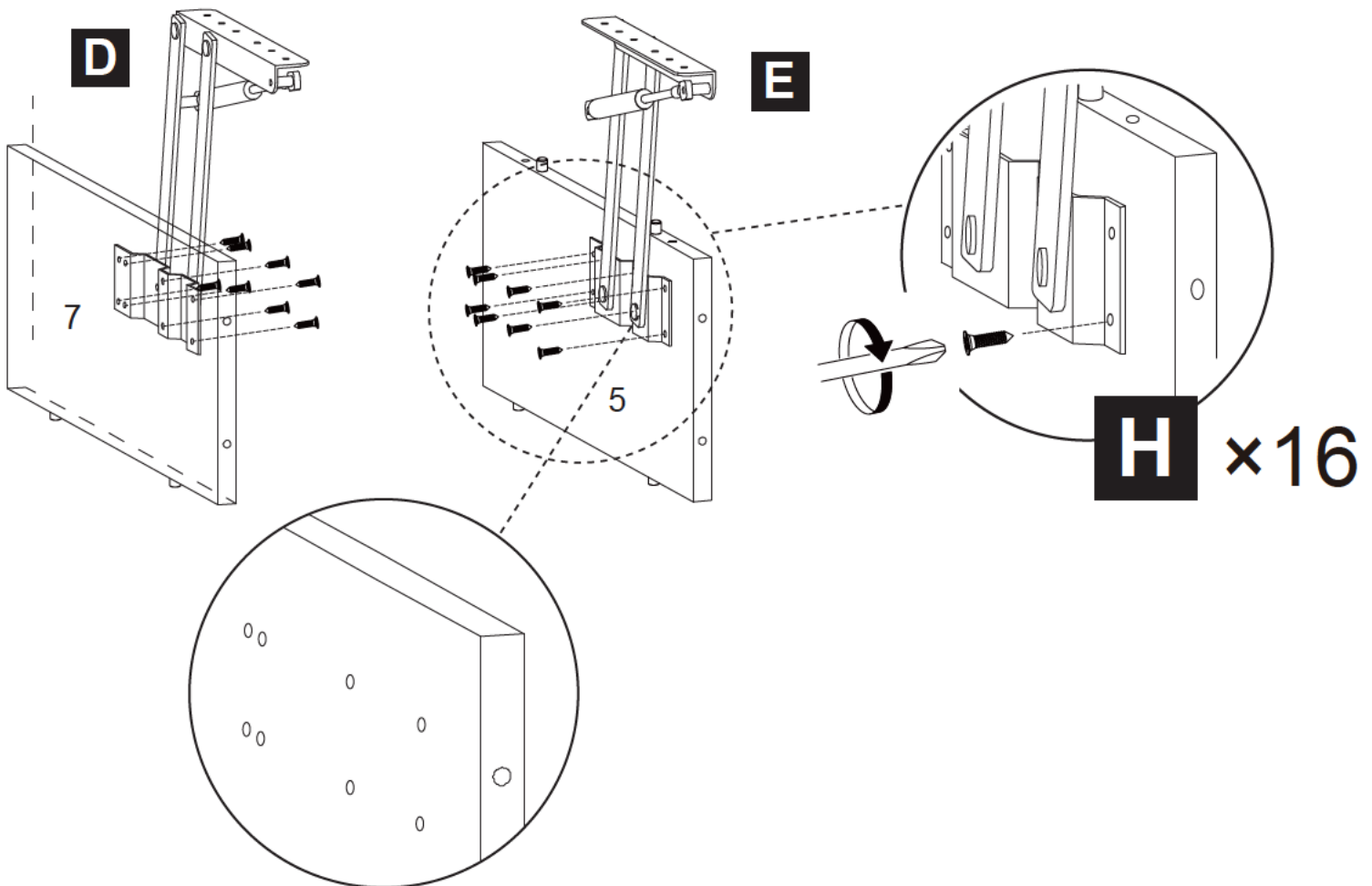
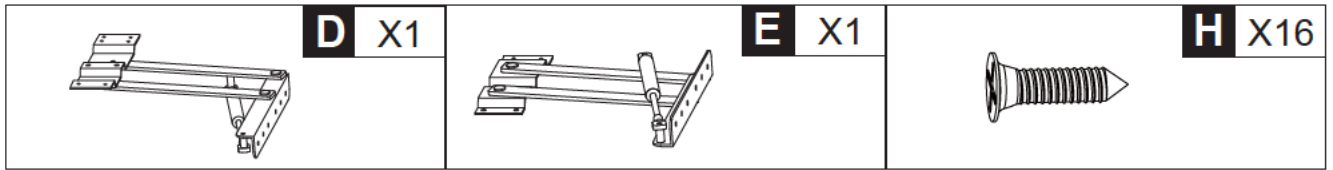

Using Bolts **(H)*16**, install Left Lifter **(D)** to the pre-drilled holes on the inside of Board **(7)**, and Right Lifter **(E)** to the pre-drilled holes on the inside of Board **(5)**.

Step 4

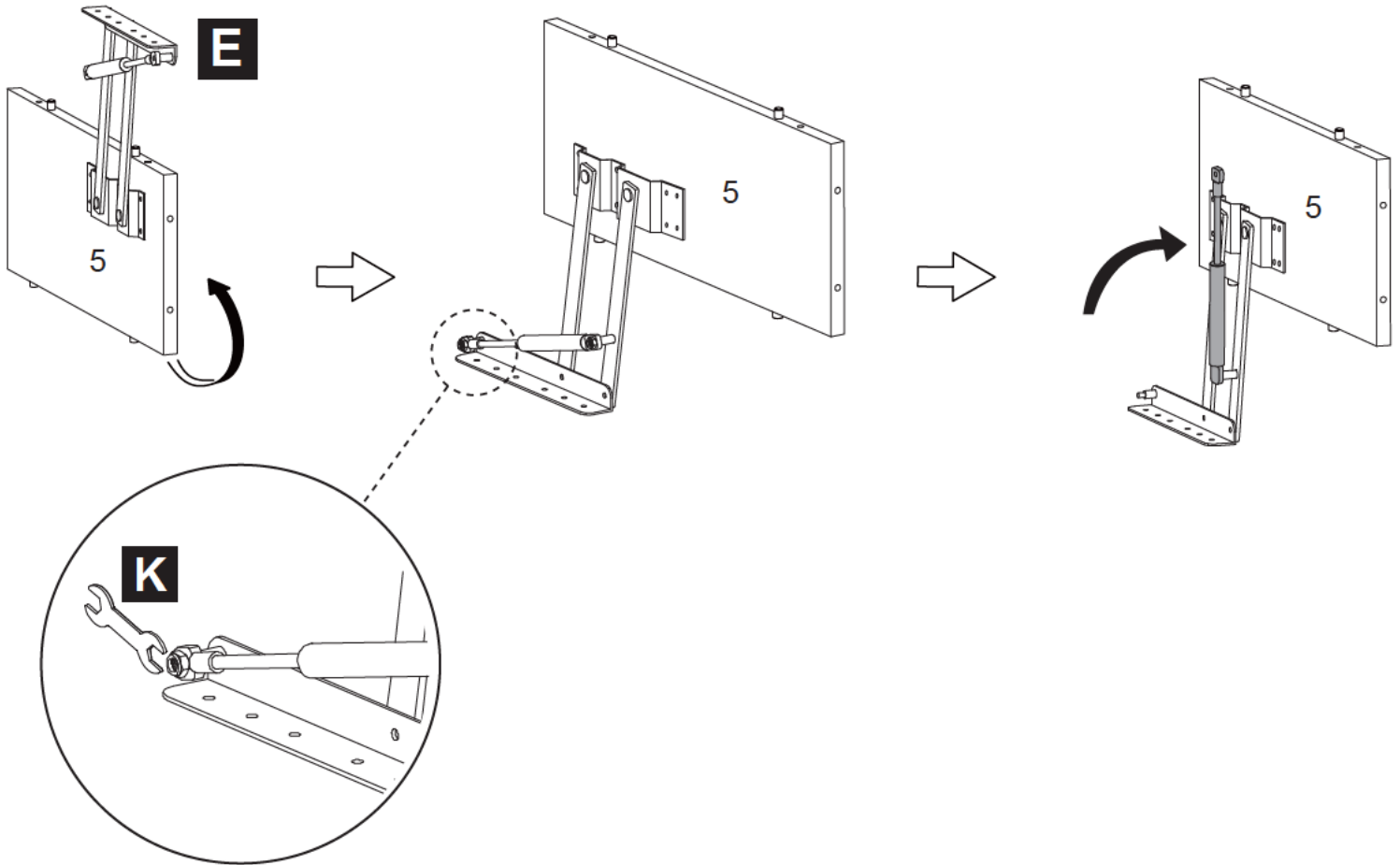
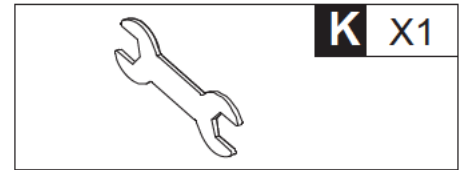

With Right Lifter (**E**) facing down, use Wrench (**K**) to unscrew the nut at the connection, then lift the damping rod.

Prepare Left Lifter (**D**) and Board (**7**) in the same way.

Step 5

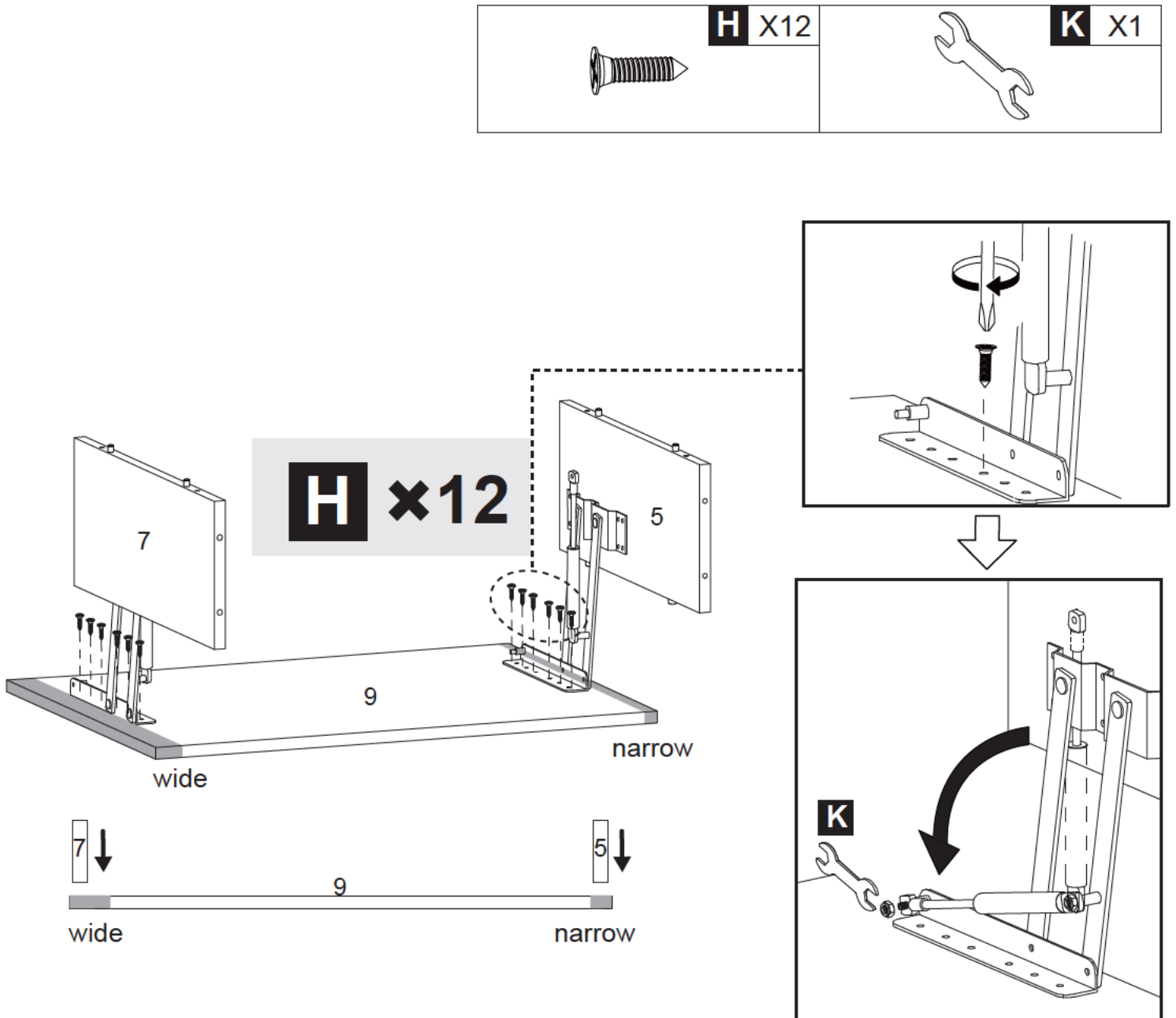

Using Bolts **(H)*12**, install Left Lifter **(D)** to the “wide” side of Board **(9)** and Right Lifter **(E)** to the “narrow” side of Board **(9)**, then lower the damping rod and re-tighten the nut with Wrench **(K)**.

Step 6

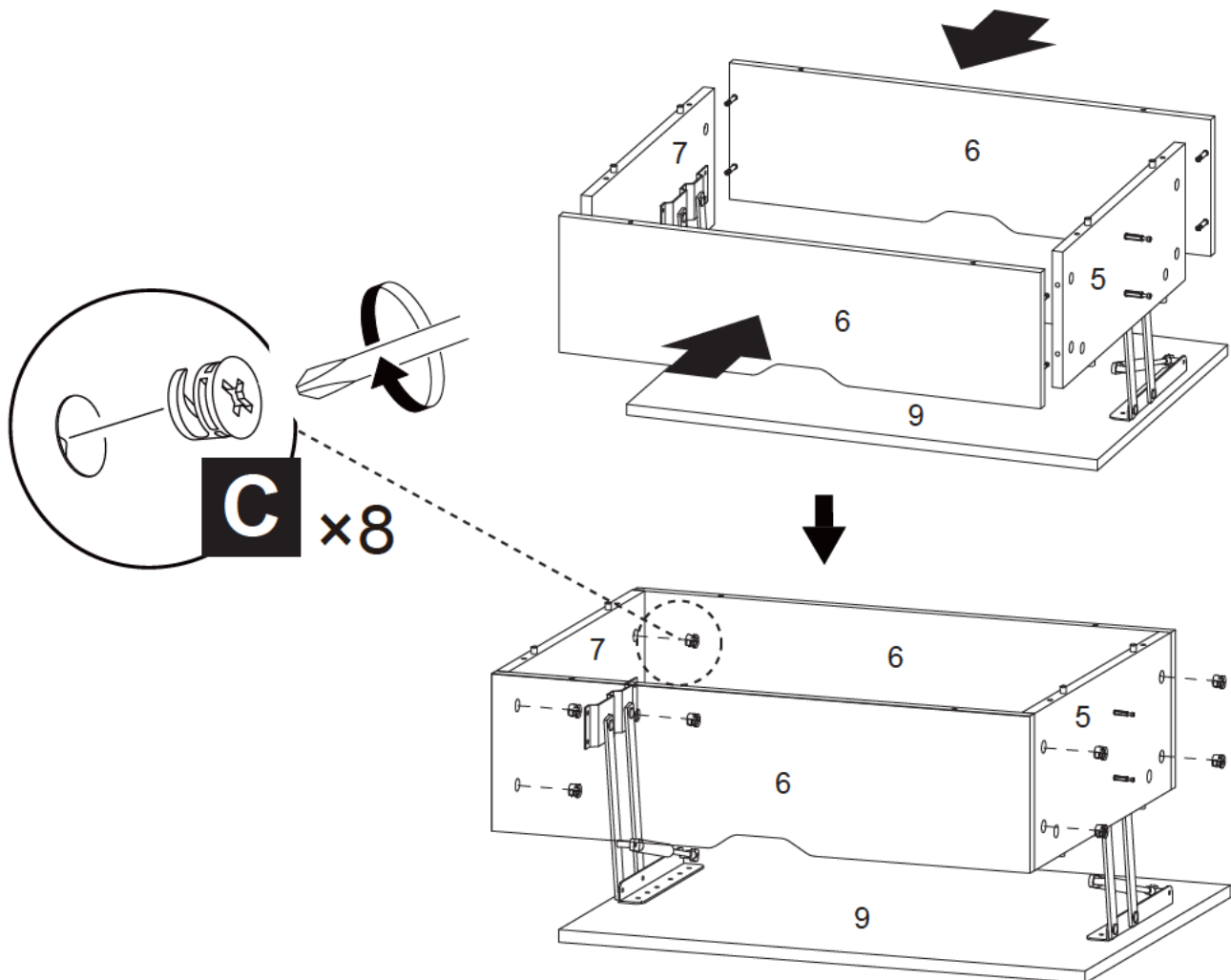
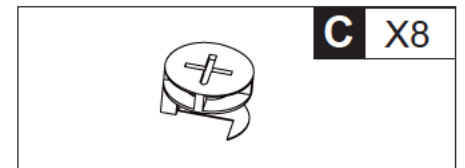

With the notched side of Board **(6)** facing down, install Board **(6)*2** to Boards **(5&7)** with Eccentric Wheel **(C)*8**.

NOTE:

The screw holes of Board **(7)** are on the inside and the screw holes of Board **(5)** are on the outside.

Step 7

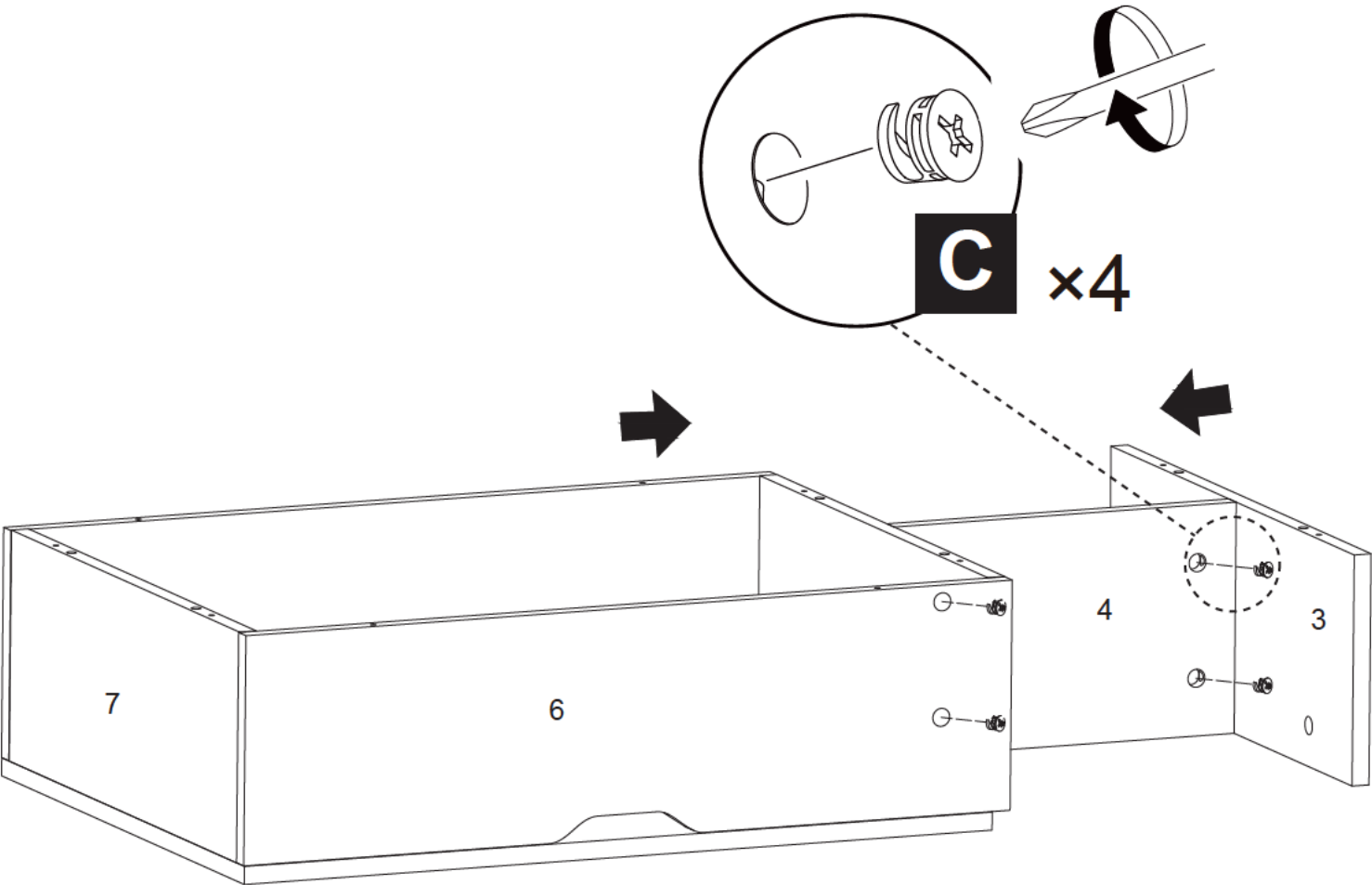

As shown, install Board (4) to Board (5), and install Board (3) to Board (4) with Eccentric Wheel (C)*4.

Step 8

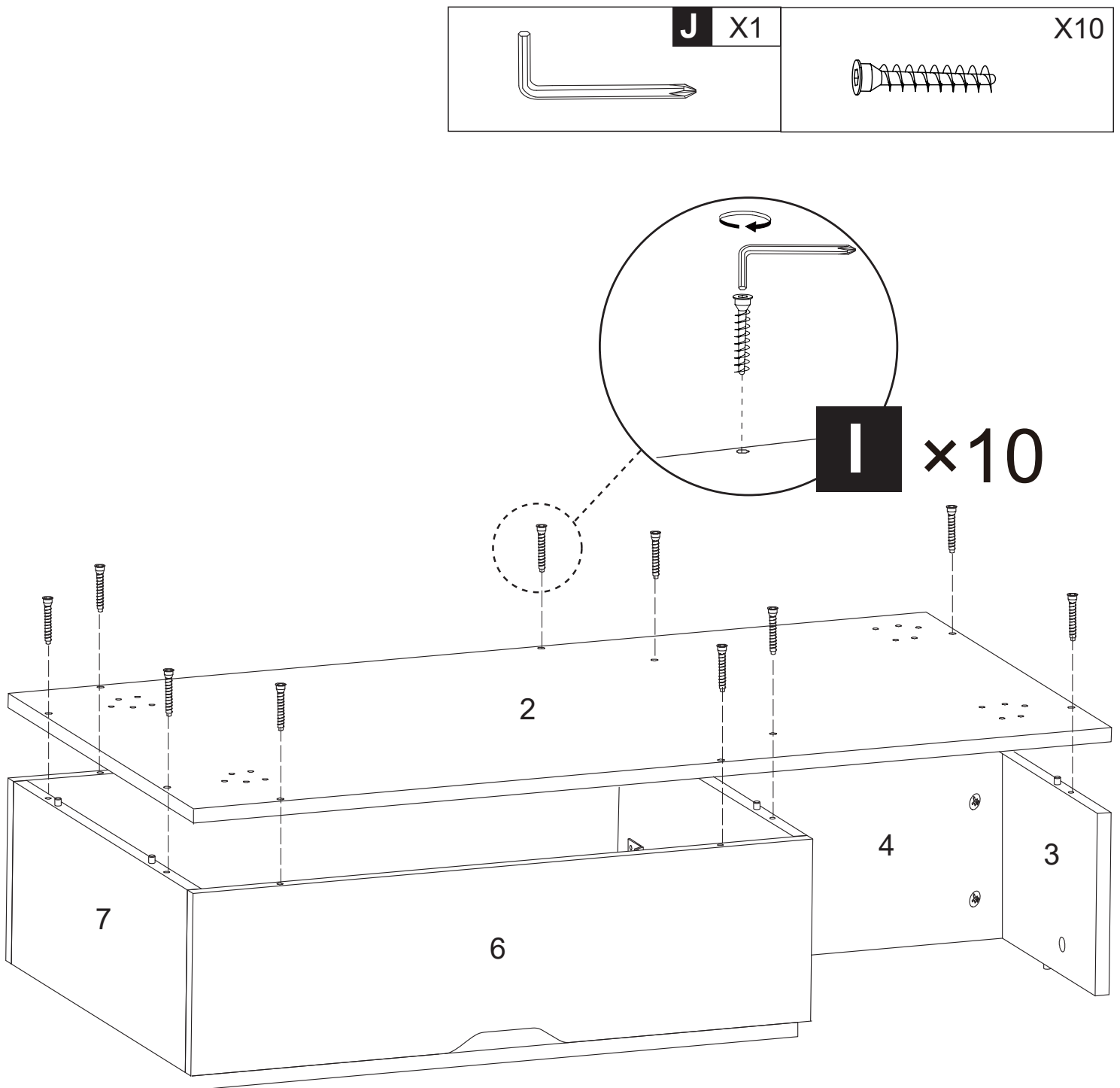

Using Wrench (**J**), install Board (**2**) to the completed frame with Bolts (**I**)*10.

Step 9

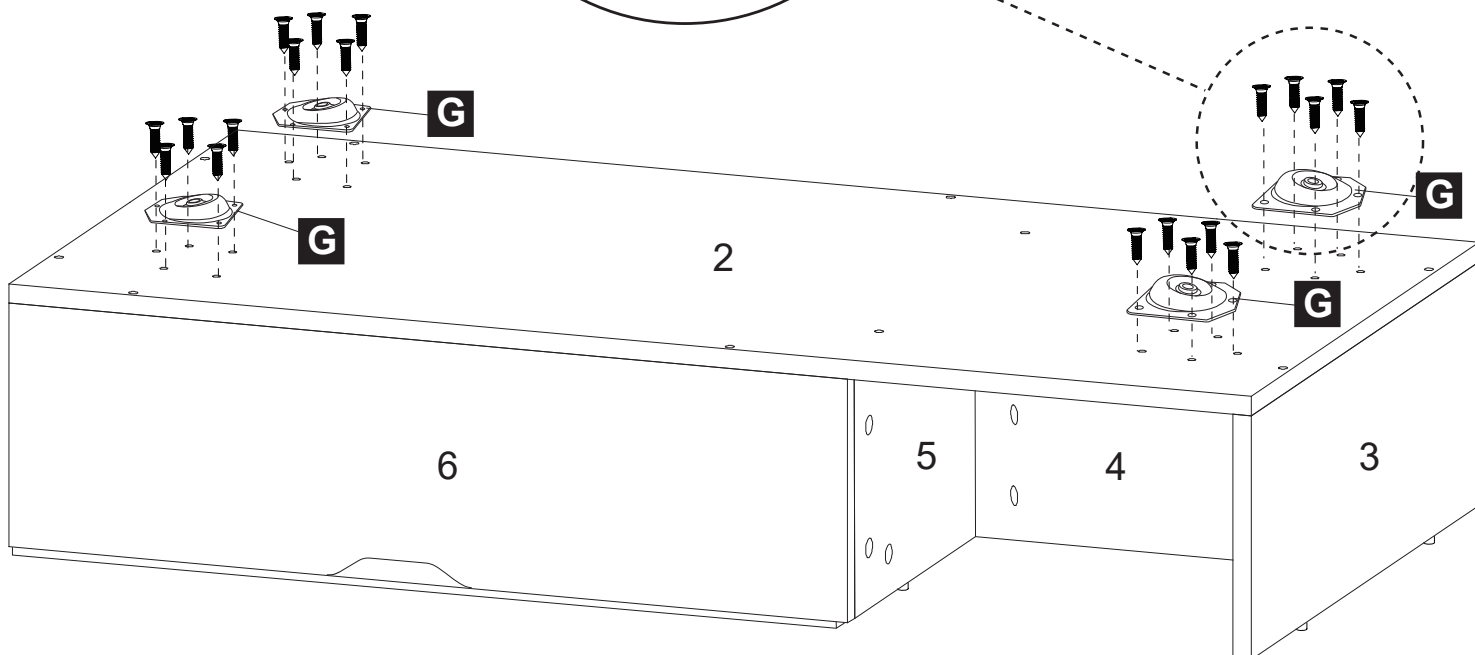
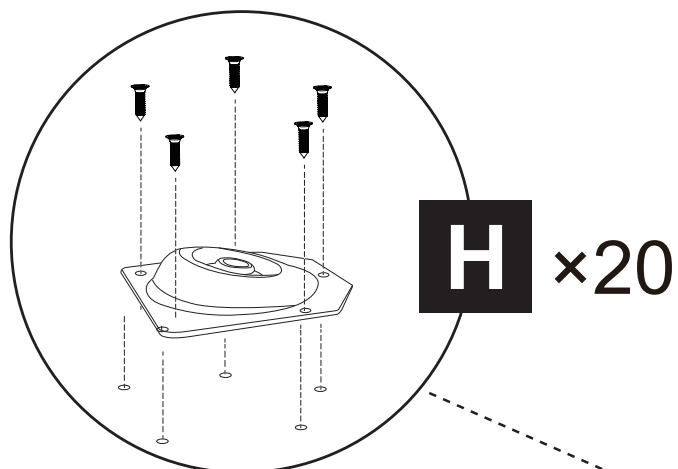
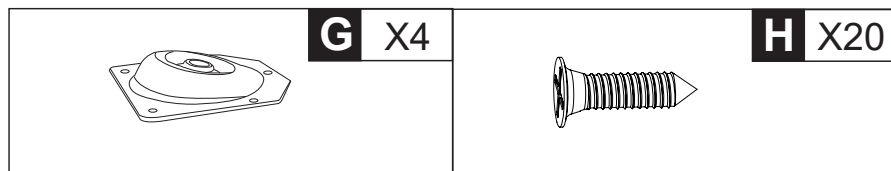

Using Bolts **(H)*20**, install Solid Wood Foot Connector **(G)*4** to the four corners of Board **(2)**.

NOTE:

The Wooden Foot Connector **(G)*4** faces outward.

Step 10

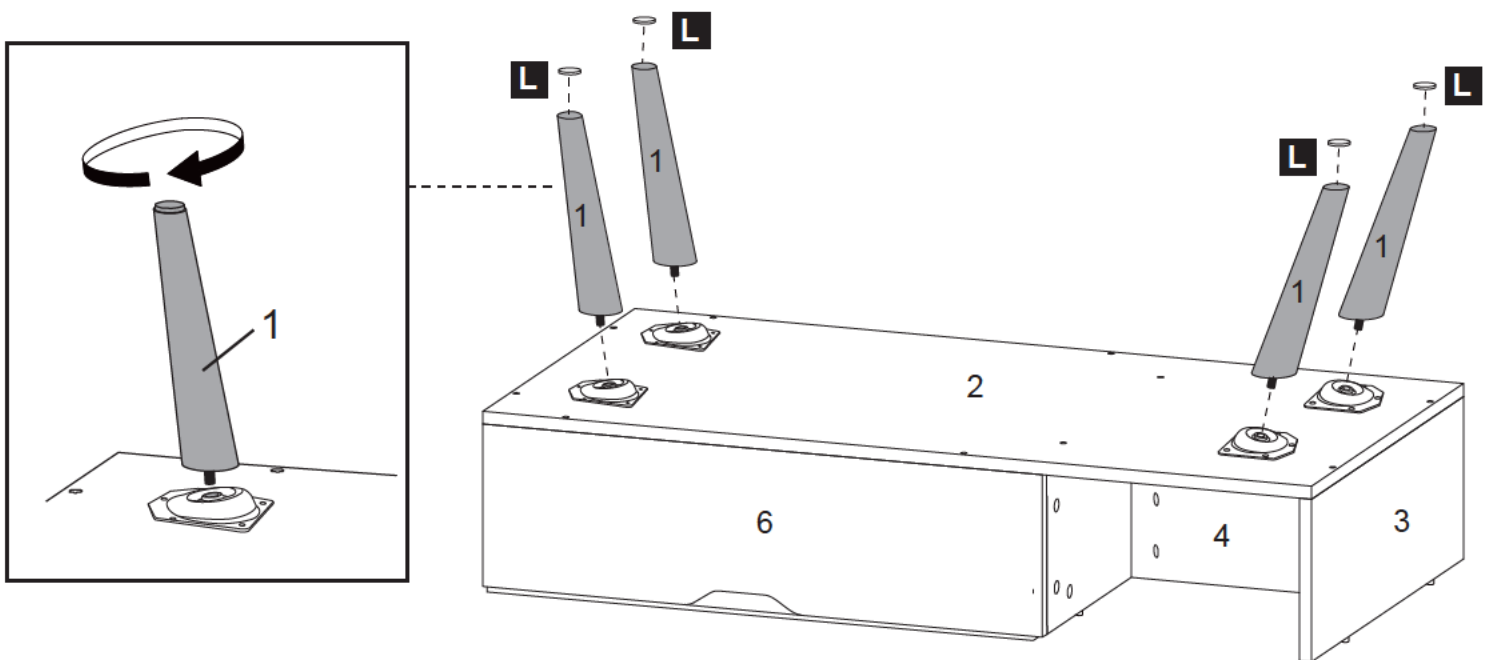
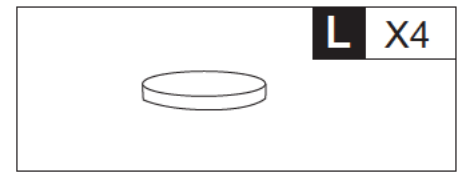

Tighten Wooden Leg (1)*4 completely, and glue Silicone Foot Pad (L)*4 on the bottom of it.

NOTE:

Please wait for 3 minutes until Silicone Foot Pad (L) are completely glued.

Step 11

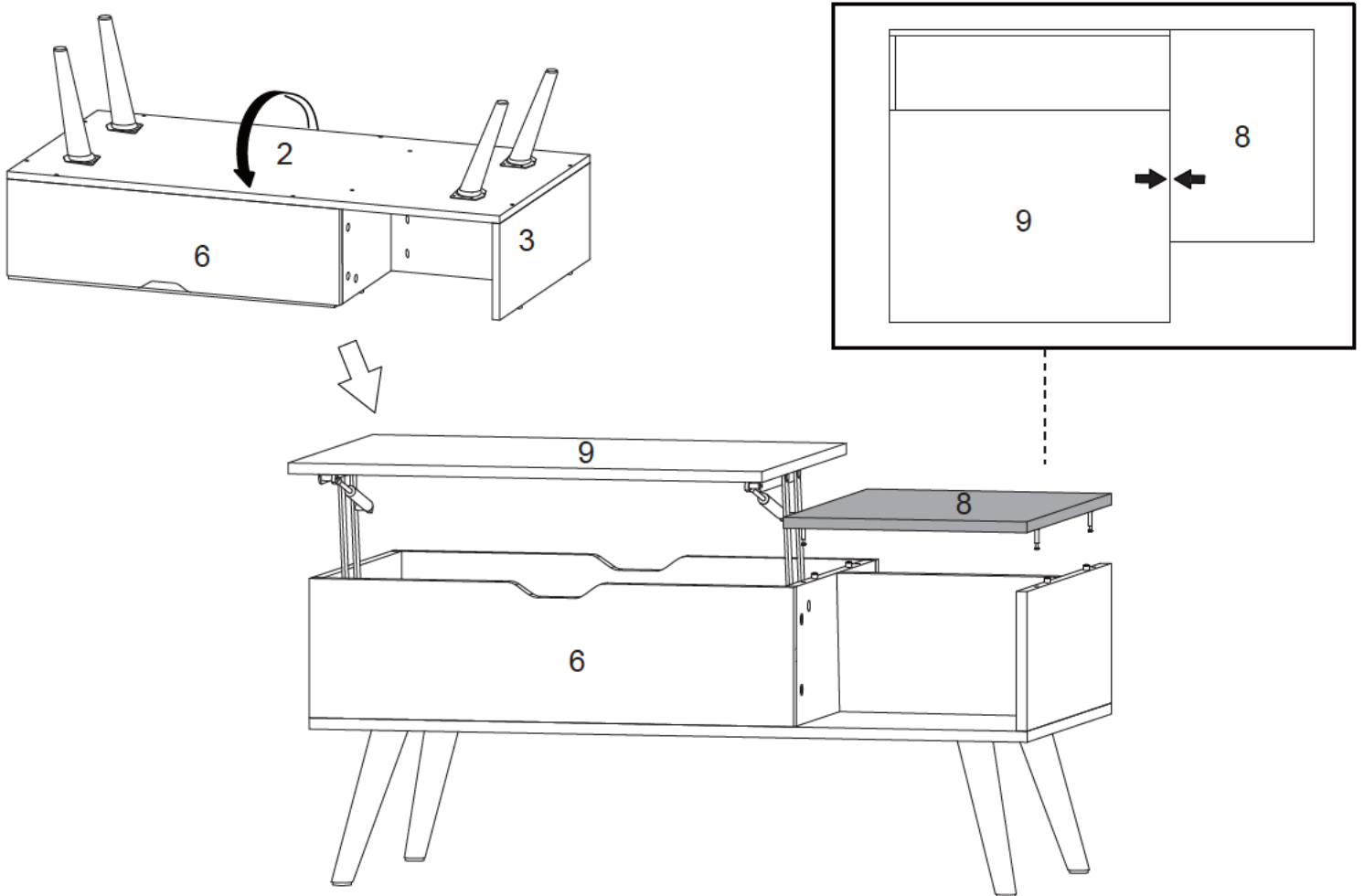

Attach Board (8) to Boards (3&5).

NOTE:

Make sure arrows on Board (9) and Board (8) point to each other.

Step 12

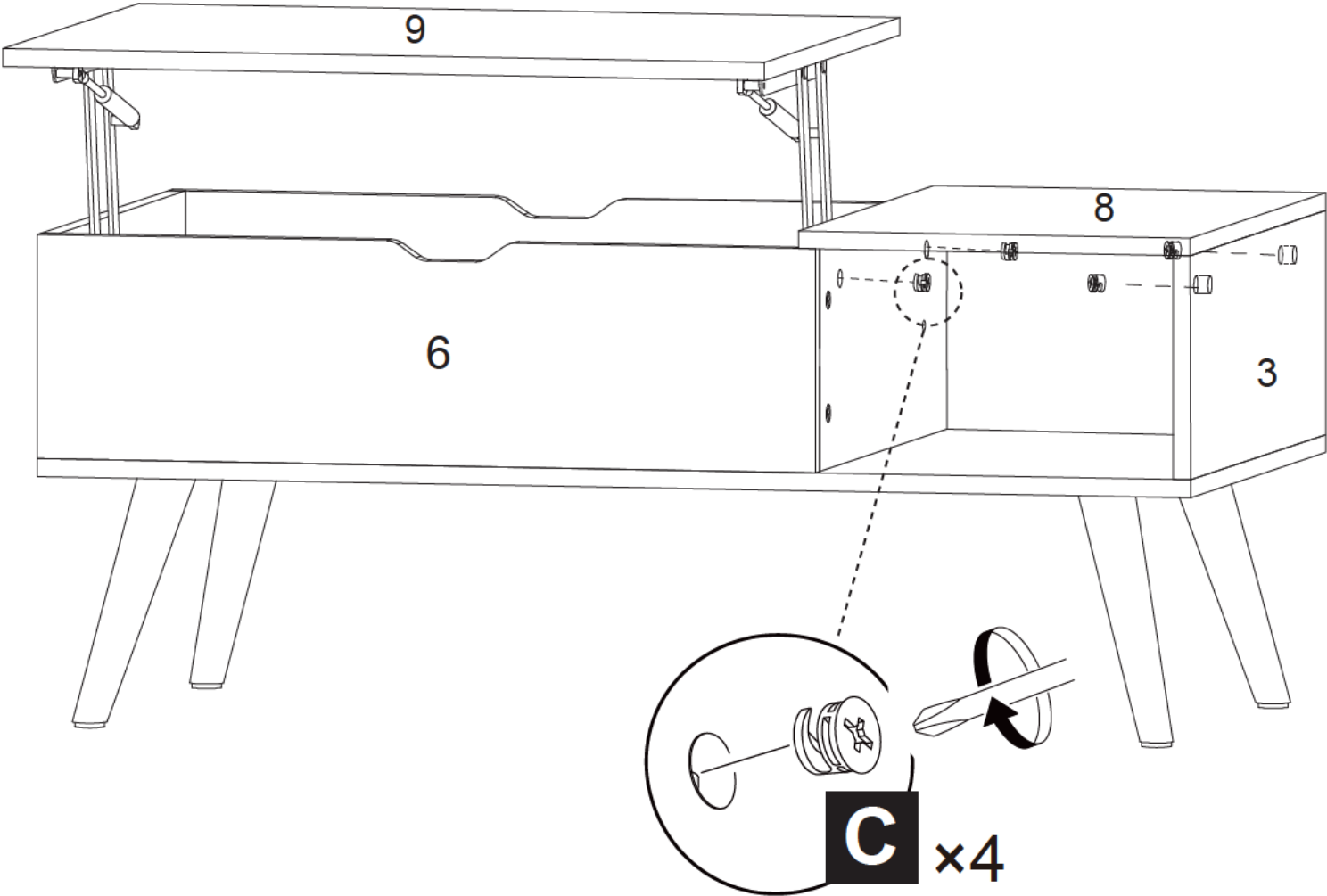
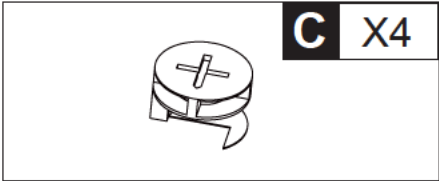

Tighten Eccentric Wheel (C)*4 and make sure Board (8) is fixed.

Step 13

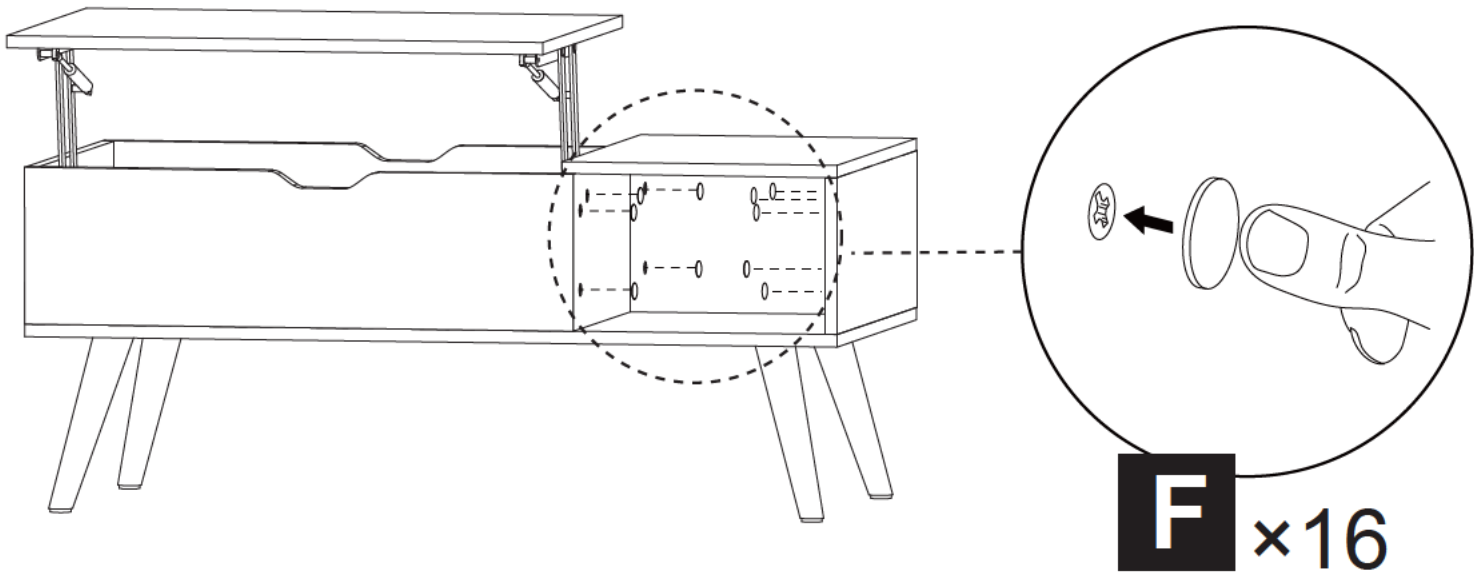
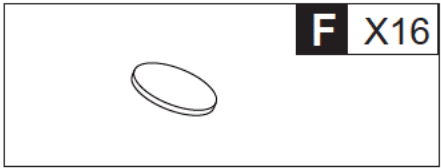

As shown, use Cover-up Sticker **(F)*16** to cover the exposed part of bolts.

