

ASSEMBLY INSTRUCTION
INSTRUCTIONS DE MONTAGE

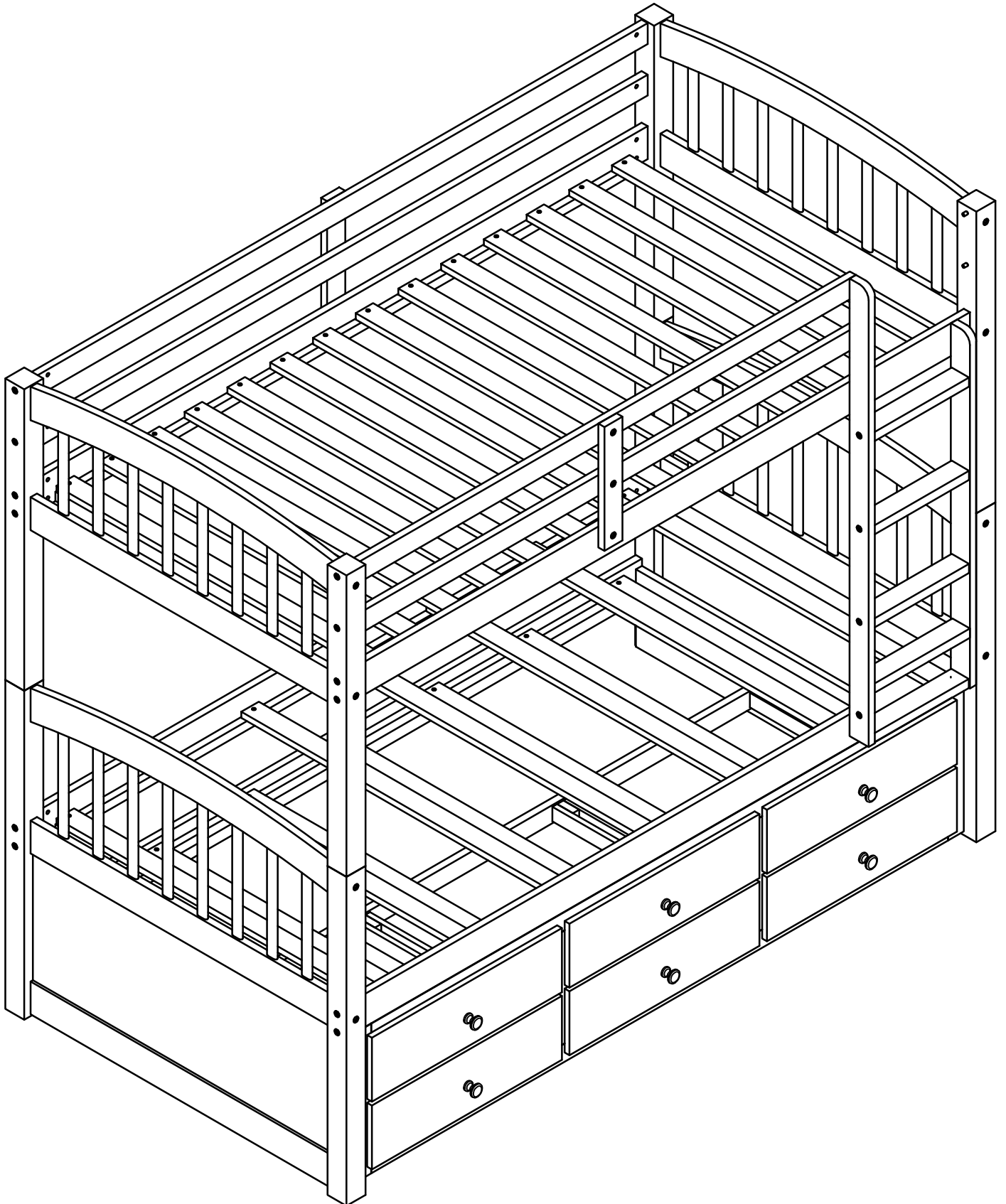

! SAFETY WARNINGS !

1. This bed is designed for use only mattress (es) meeting the following specifications on the upper bunk, and lower bunk

Upper bed

Bed Type	Length	Width	Thickness
<i>Twin Standard</i>	<i>74" - 75"</i>	<i>38 1/2"</i>	<i>6" max</i>

Lower bed

Bed Type	Length	Width	Thickness
<i>Twin Standard</i>	<i>74" - 75"</i>	<i>38 1/2"</i>	<i>8" max</i>

2. Replacement parts, including additional guardrails, maybe obtained from any of our dealers
3. Follow the information on the warnings appearing on the upper bunk bed end structure and on the carton. Do not remove warning label from bed
4. Always use the recommended size mattresses or mattress supports, or both, to help prevent the likelihood of entrapment or falls.
5. Surface of mattress must be at least 5" (127mm) below the upper edge of guardrails
6. Do not allow children under 6 years of age to use the upper bunk.
7. Periodically check and ensure that the guardrail, ladder, and other components are in their proper position, free from damage, and that all connectors are tight.
8. Do not allow horseplay on or under the bed and prohibit jumping on the bed.
9. Always use the ladder for entering and leaving the upper bunk.
10. Do not use substitute part. Contact the manufacture or dealer for replacement part
11. Use of a night light may provide added safety precaution for a child using the upper bunk..
12. Always use guardrails on both long sides of the upper bunk. If the bunk bed will be placed next to the wall, the guardrail that runs the full length of the bed should be placed against the wall to prevent entrapment between the bed and wall.
13. The use of water or sleep flotation mattresses is prohibited
14. STRANGULATION HAZARD - Never attach or hang items to any part of the bunk bed that are not designed for use with the bed; for example, but not limited to, hook, belts and jump ropes
15. Keep these instruction for future reference
16. Prohibit more than one person on upper bunk
17. We recommend assembling your bunk bed on the shipping carton to protect your floor or carpet
18. Be certain all staples are out of the box before beginning assembly on the shipping carton.

! AVERTISSEMENTS DE SÉCURITÉ !

1. Ce lit est conçu pour utiliser uniquement des matelas répondant aux spécifications suivantes sur le lit supérieur, et couchette inférieure

Lit supérieur

Type de lit	Longueur	Largeur	Épaisseur
Twin Standard	74" - 75"	38 1/2"	6" max

Lit inférieur

Type de lit	Longueur	Largeur	Épaisseur
Twin Standard	74" - 75"	38 1/2"	8" max

2. Les pièces de rechange, y compris les garde-corps supplémentaires, peuvent être obtenues auprès de l'un de nos revendeurs.
3. Suivez les informations sur les avertissements apparaissant sur la structure d'extrémité supérieure du lit superposé et sur le carton. Ne retirez pas l'étiquette d'avertissement du lit.
4. Utilisez toujours des matelas ou des supports de matelas de taille recommandée, ou les deux, pour éviter tout risque de coincement ou de chute.
5. La surface du matelas doit être à au moins 5" (127 mm) sous le bord supérieur des garde-corps.
6. Ne laissez pas les enfants de moins de 6 ans utiliser le lit supérieur.
7. Vérifiez et assurez-vous périodiquement que le garde-corps, l'échelle et les autres composants sont dans leur position correcte, exempts de dommages et que tous les connecteurs sont bien serrés.
8. Ne permettez pas les chahuts sur ou sous le lit et interdisez de sauter sur le lit.
9. Utilisez toujours l'échelle pour entrer et sortir du lit supérieur.
10. N'utilisez pas de pièce de rechange. Contactez le fabricant ou le revendeur pour une pièce de rechange.
11. L'utilisation d'une veilleuse peut fournir une mesure de sécurité supplémentaire pour un enfant utilisant le lit supérieur.
12. Utilisez toujours des garde-corps sur les deux côtés longs du lit supérieur. Si le lit superposé doit être placé à côté du mur, le garde-corps qui s'étend sur toute la longueur du lit doit être placé contre le mur pour éviter tout coincement entre le lit et le mur.
13. L'utilisation de matelas flottants à eau ou de sommeil est interdite.
14. **RISQUE D'ÉTRANGULATION** - N'attachez ou ne suspendez jamais d'objets à une partie du lit superposé qui ne sont pas conçus pour être utilisés avec le lit ; par exemple, mais sans s'y limiter, des crochets, des ceintures et des cordes à sauter.
15. Conservez ces instructions pour référence future.
16. Interdire plus d'une personne sur la couchette supérieure.
17. Nous vous recommandons d'assembler votre lit superposé sur le carton d'expédition pour protéger votre sol ou votre tapis.
18. Assurez-vous que toutes les agrafes sont sorties de la boîte avant de commencer l'assemblage sur le carton d'expédition.



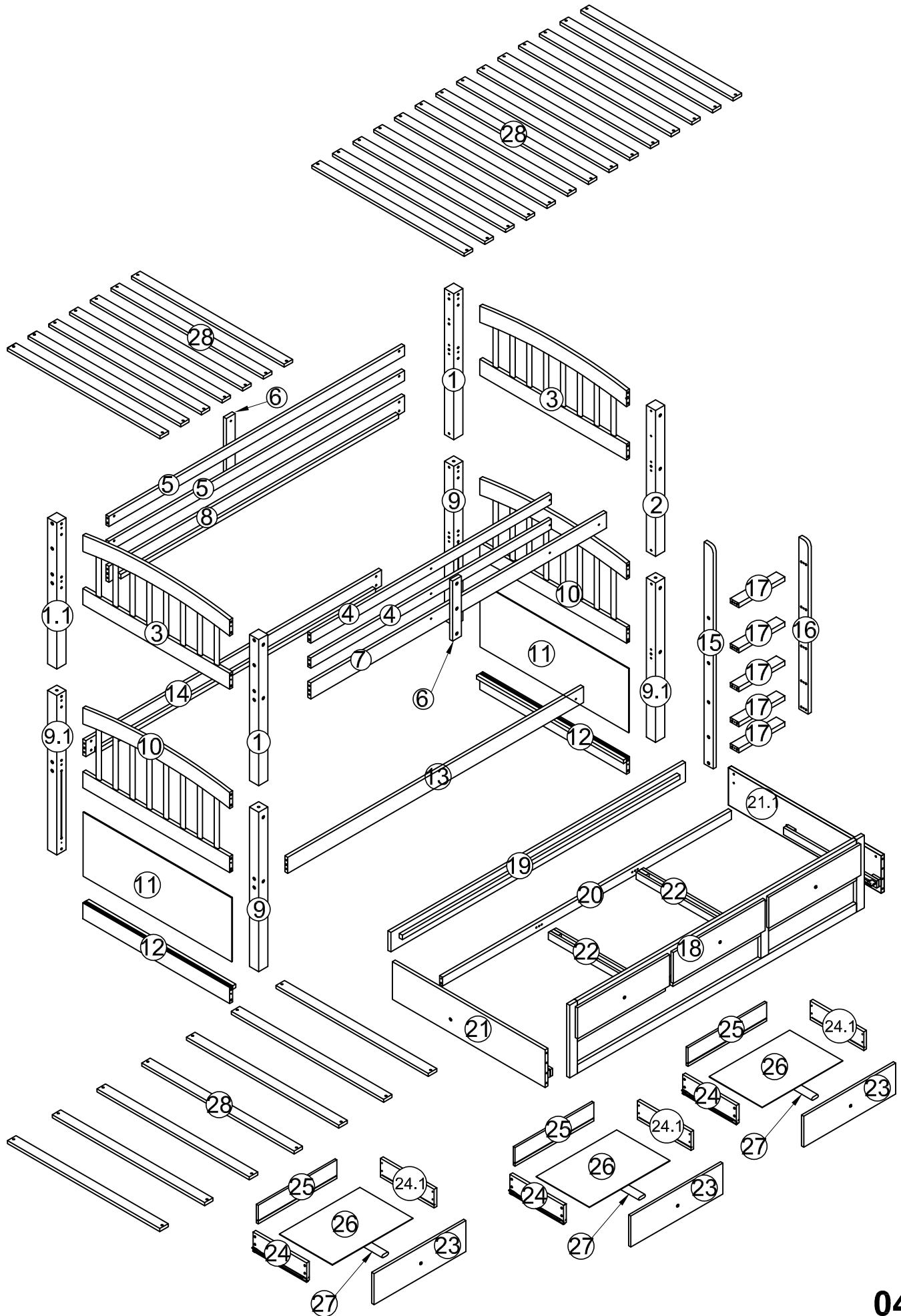

ASSEMBLY INSTRUCTION

INSTRUCTIONS DEMONTAGE



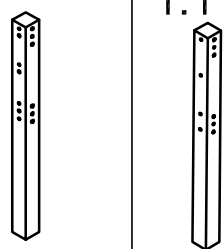

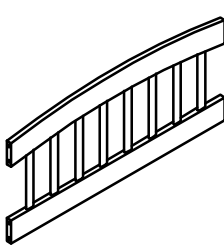
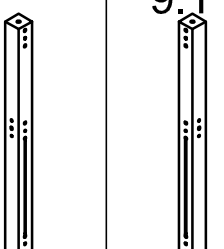

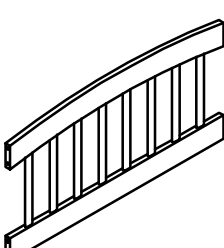
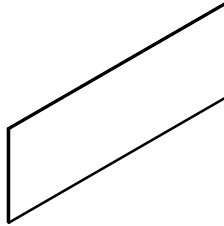
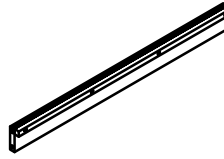
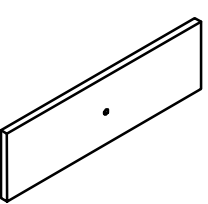
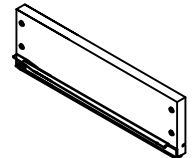
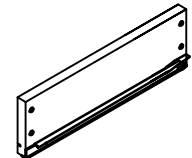
Part List & Hardware List Box 1

Liste des pièces et liste du matériel

<p>1</p>  <p>2pcs Upper Legs haut des jambes</p>	<p>1.1</p>  <p>1pc Upper Legs-1pc haut des jambes</p>	<p>2</p>  <p>Upper Legs-1pc haut des jambes</p>	<p>3</p>  <p>wood frame-2pcs cadre en bois</p>	<p>9</p>  <p>2pcs Upper Legs haut des jambes</p>
<p>9.1</p>  <p>2pcs Upper Legs haut des jambes</p>	<p>10</p>  <p>wood frame-2pcs cadre en bois</p>	<p>11</p>  <p>Panel-2pcs Planche</p>	<p>12</p>  <p>WoodBar-2pcs Barres de bois</p>	<p>23</p>  <p>Panel-2pcs Planche</p>
<p>24</p>  <p>Panel-3pcs Planche</p>	<p>24.1</p>  <p>Panel-3pcs Planche</p>			

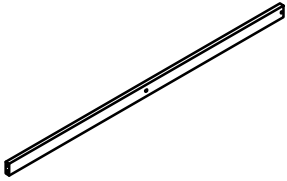
Part List Box 2

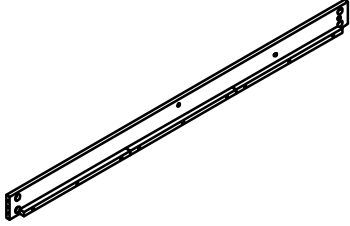
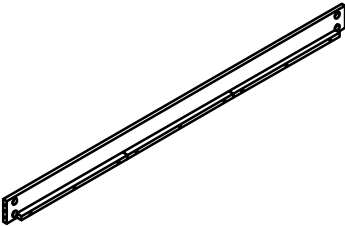
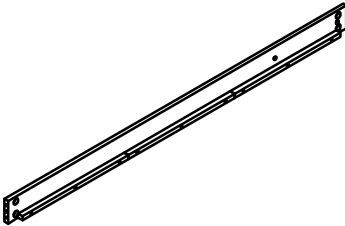
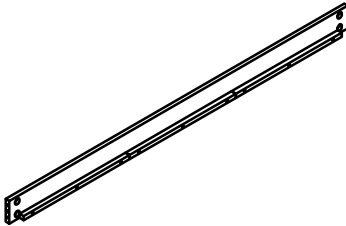
Liste des pièces

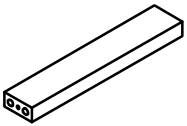
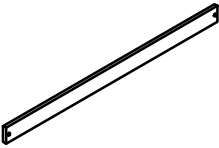
<p>4</p>  <p>WoodBar-2pcs Barres de bois</p>	<p>5</p>  <p>WoodBar-2pcs Barres de bois</p>	<p>6</p>  <p>WoodBar-2pcs Barres de bois</p>	<p>7</p>  <p>WoodBar-1pc Barres de bois</p>
<p>8</p>  <p>Side rail-1pc barrière latérale</p>	<p>13</p>  <p>Side rail-1pc barrière latérale</p>	<p>14</p>  <p>Side rail-1pc barrière latérale</p>	<p>15</p>  <p>WoodBar-1pc Barres de bois</p>
<p>16</p>  <p>WoodBar-1pc Barres de bois</p>	<p>17</p>  <p>WoodBar-5pcs Barres de bois</p>	<p>28</p>  <p>Slats-28pcs Lattes</p>	





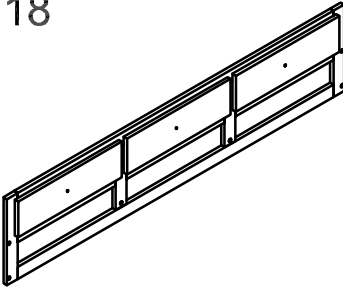
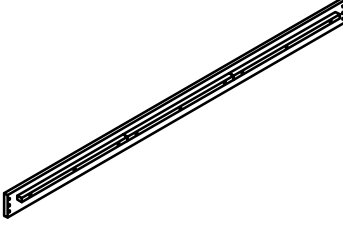
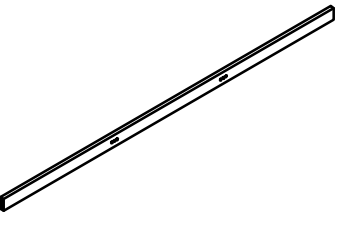
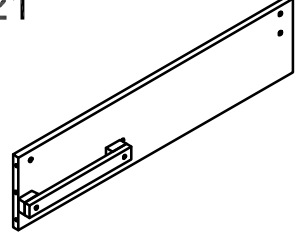
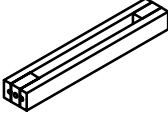
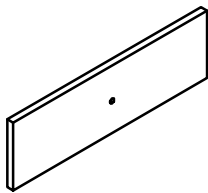
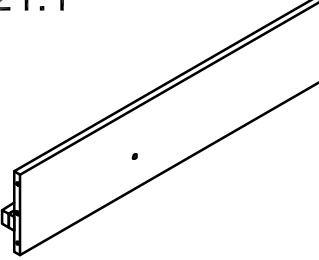
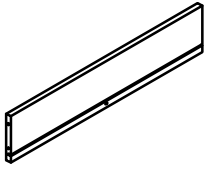
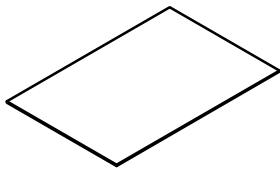
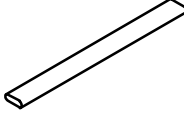



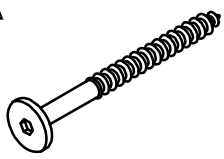
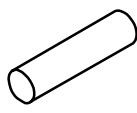
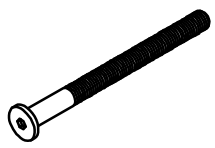

Part List Box 3

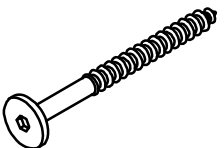
Liste des pièces

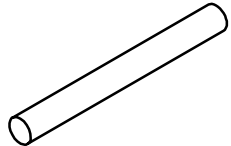
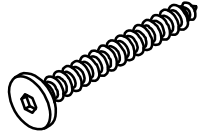
<p>18</p>  <p>wood frame-1pc cadre en bois</p>	<p>19</p>  <p>WoodBar-1pc Barres de bois</p>	<p>20</p>  <p>WoodBar-1pc Barres de bois</p>	<p>21</p>  <p>Panel-1pc Planche</p>
<p>22</p>  <p>WoodBar-2pcs Barres de bois</p>	<p>23</p>  <p>Panel-1pc Planche</p>	<p>21.1</p>  <p>Panel-1pc Planche</p>	<p>25</p>  <p>Panel-3pcs Planche</p>
<p>26</p>  <p>Panel-3pcs Planche</p>	<p>27</p>  <p>WoodBar-3pcs Barres de bois</p>		

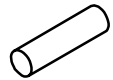
Hardware List Box 1

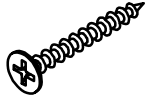
Liste du matériel

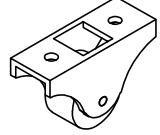
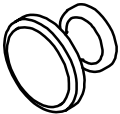
<p>A</p>  <p>Screws 1/4" x 100mm -20pcs Vis</p>	<p>B</p>  <p>Wood dowel Ø10 x 40 mm - 74pcs Cheville en bois</p>	<p>C</p>  <p>Bolts Ø1/4" x 100 mm - 22pcs Boulon</p>	<p>D</p>  <p>Ø1/4" x 13 mm Horizontal-Hole bolts-30pcs Boulons à trou horizontal</p>	<p>E</p>  <p>Screws 1/4" x 30mm - 6pcs Vis</p>
<p>W</p>  <p>Small Bplt-6pcs petit boulon</p>	<p>G</p>  <p>Wood dowel Ø12 x 110 mm - 4pcs Cheville en bois</p>	<p>H</p>  <p>Screws 1/4" x 50mm -12pcs Vis</p>	<p>I</p>  <p>Bolts Ø1/4" x 35 mm - 10pcs Boulon</p>	<p>J</p>  <p>Wood dowel Ø8 x 30 mm - 16pcs Cheville en bois</p>
<p>K</p>  <p>Bolts Ø1/4" x 70mm-8pcs Boulon</p>	<p>P</p>  <p>Allen Key - 1pc Clé Allen</p>	<p>M</p>  <p>Wood Screws M4 x 30mm - 91pcs Les vis à bois</p>	<p>N</p>  <p>Wood Screws M4 x 20mm - 8pcs Les vis à bois</p>	<p>O</p>  <p>Wheels-4pcs Roues</p>
<p>Q</p>  <p>Knots-6pcs Noeuds</p>				

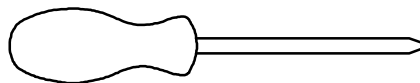

Assembly Tools Required (Not Included)
Outils d'assemblage requis (Non Inclus)

STEP 1:

Étape 1:

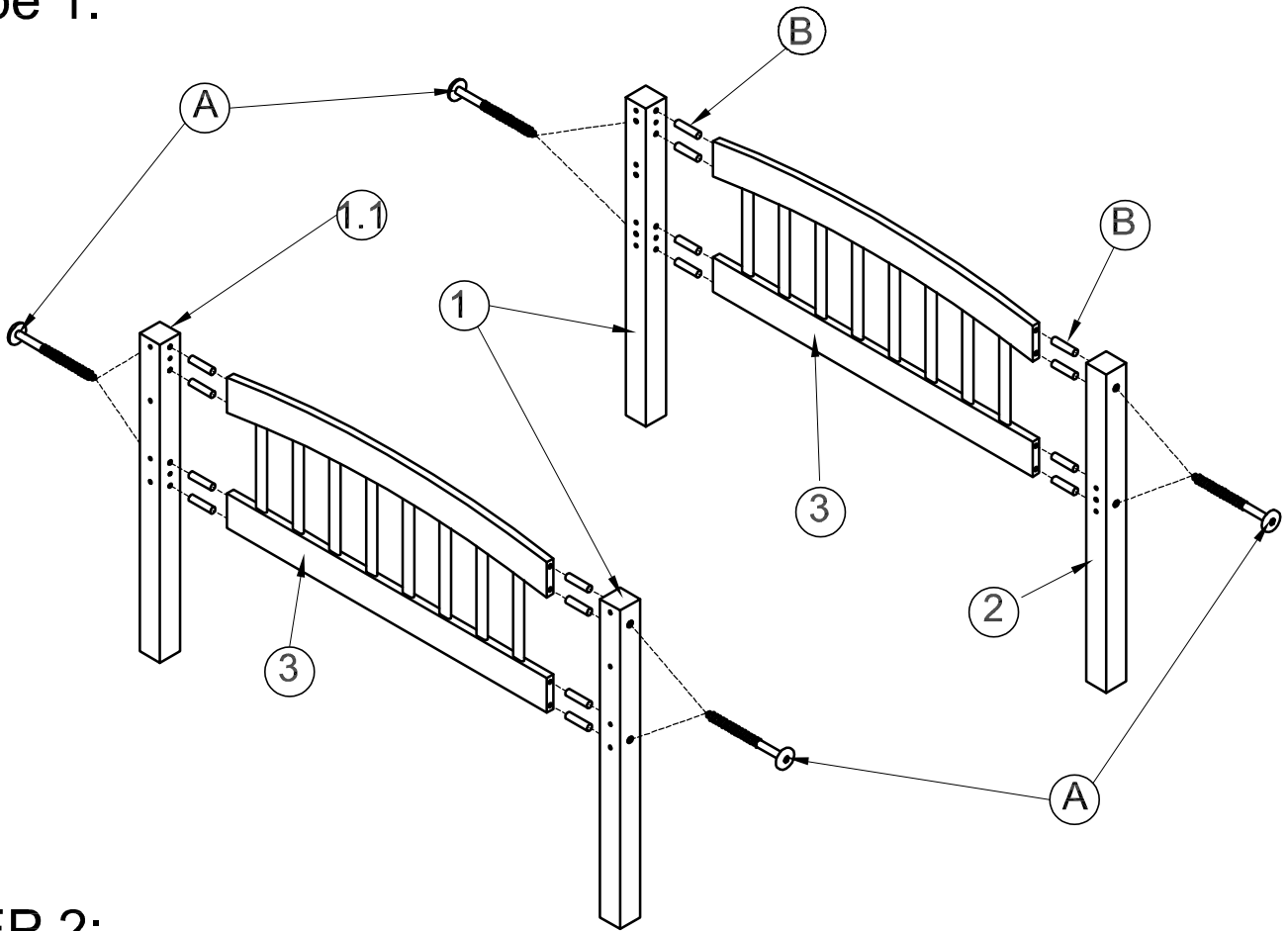

STEP 2:

Étape 2:

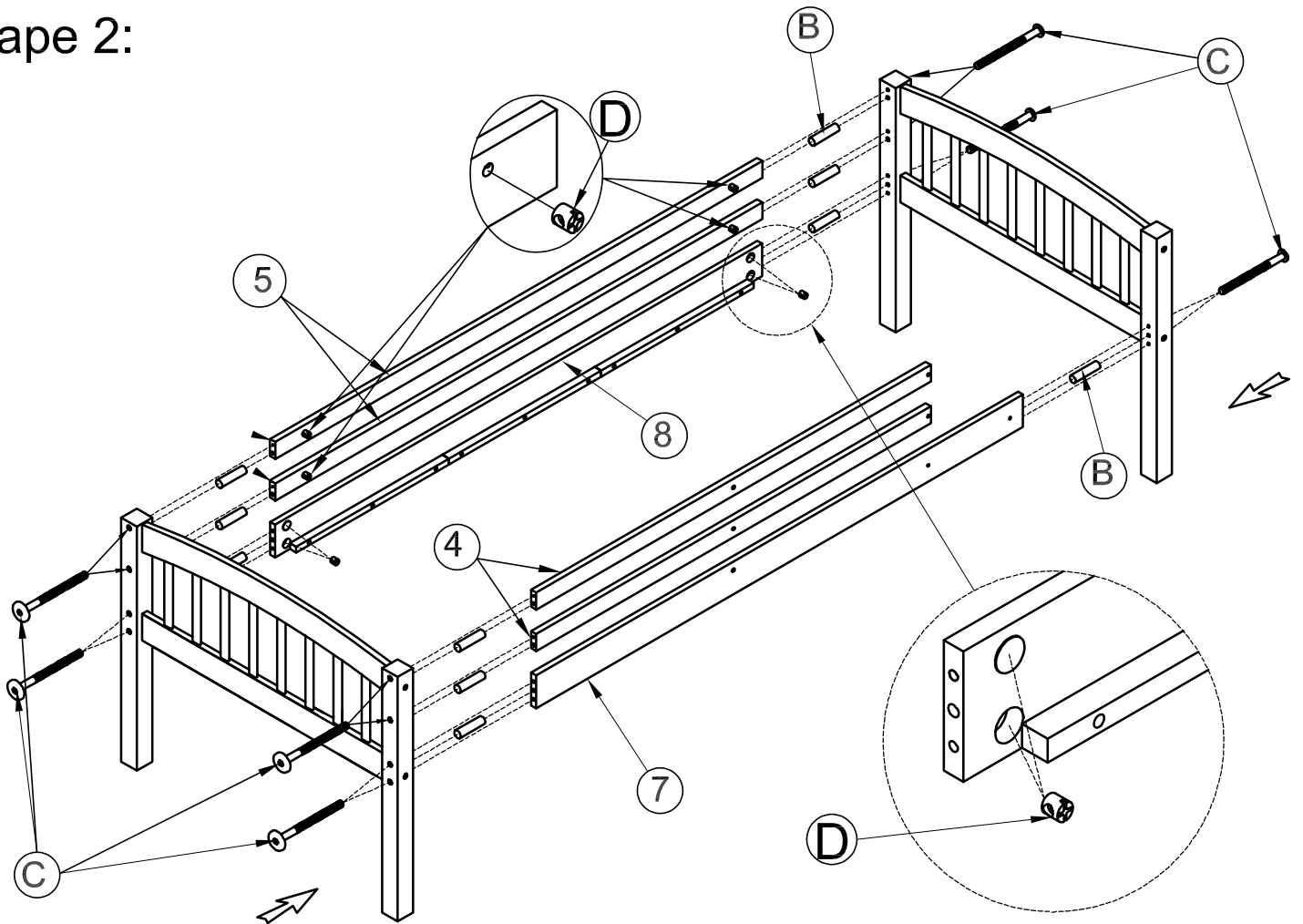

STEP 3:

Étape 3:

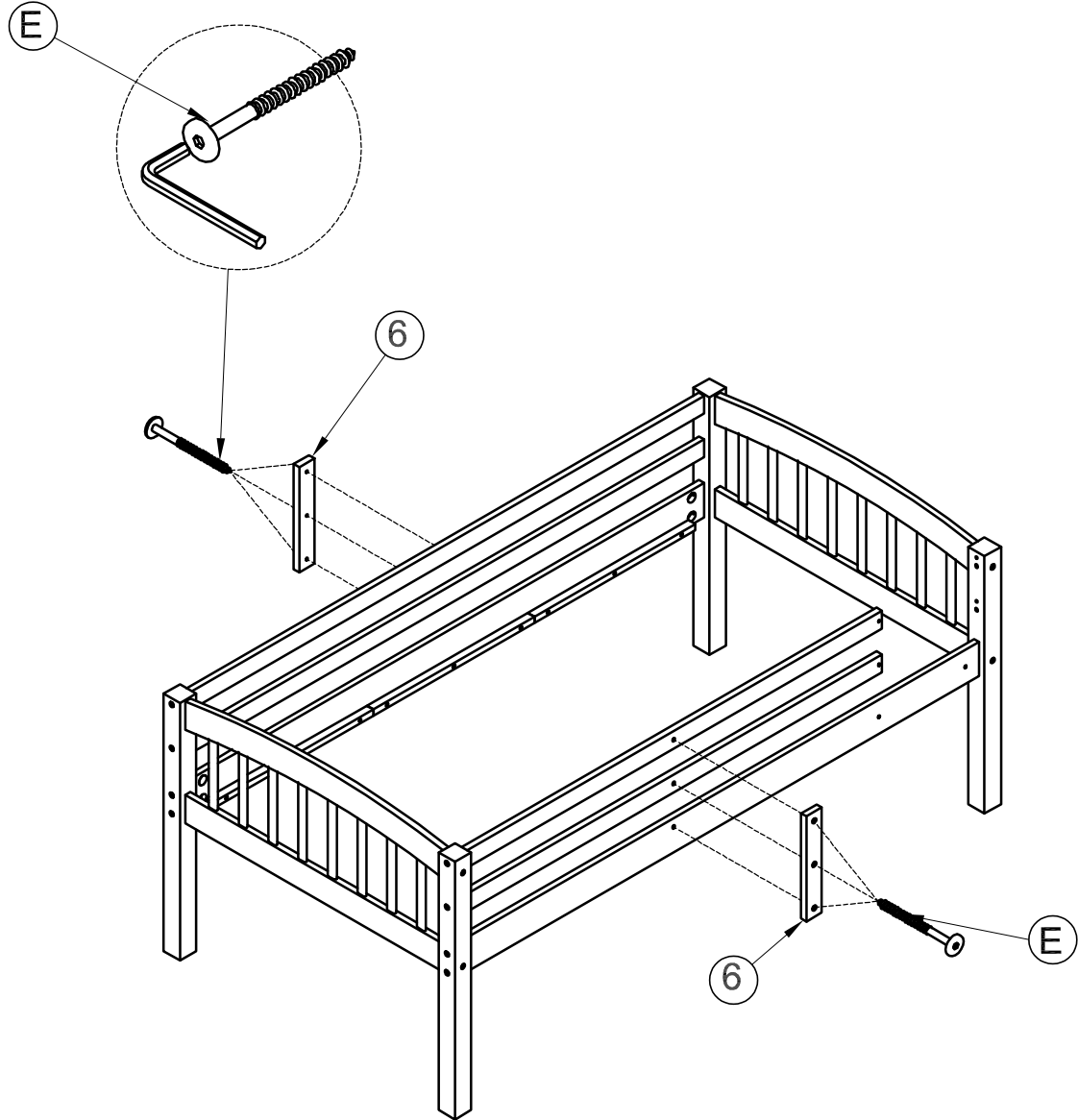

STEP 6:

Étape 6:

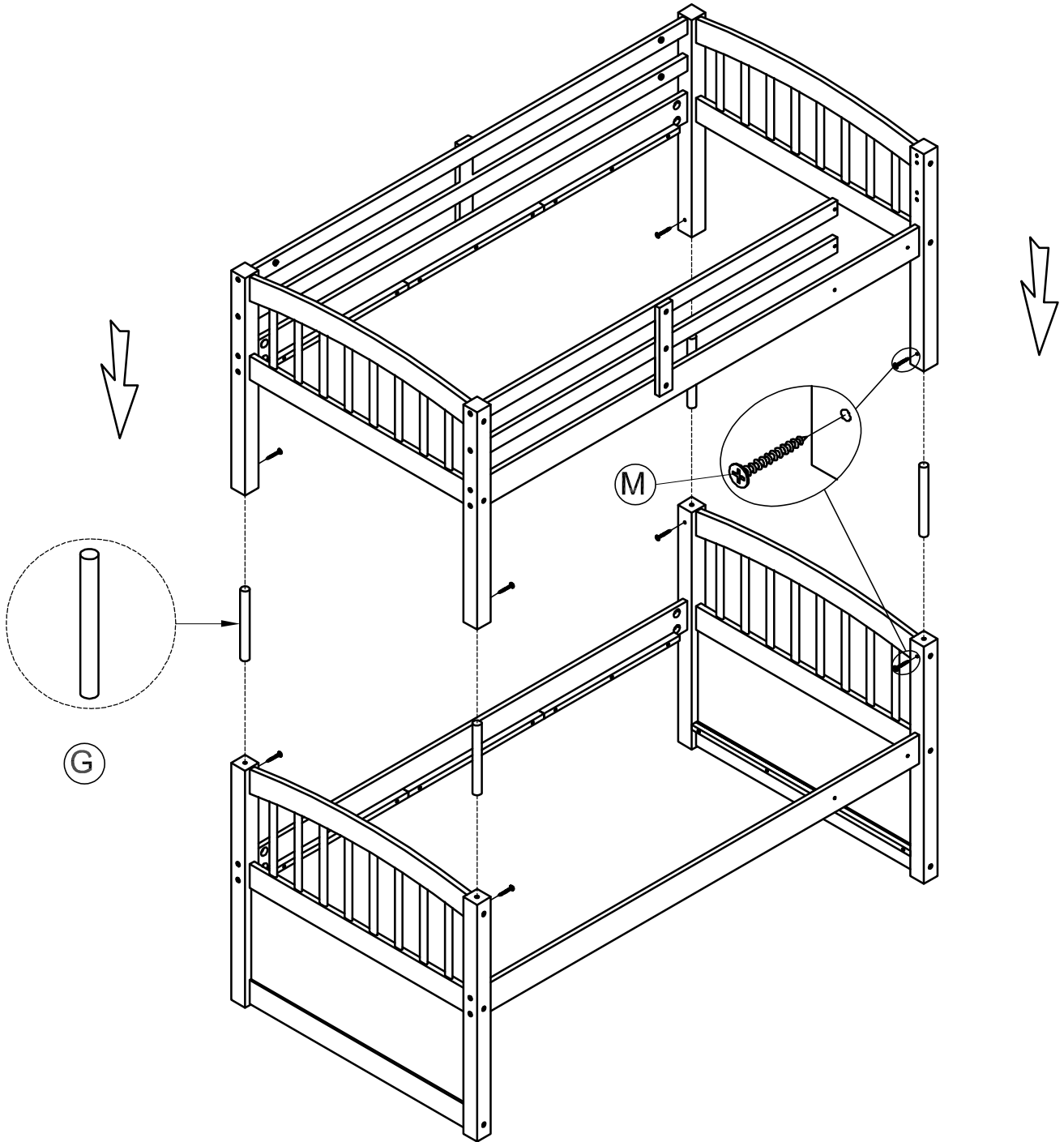

STEP 7:

Étape 7:

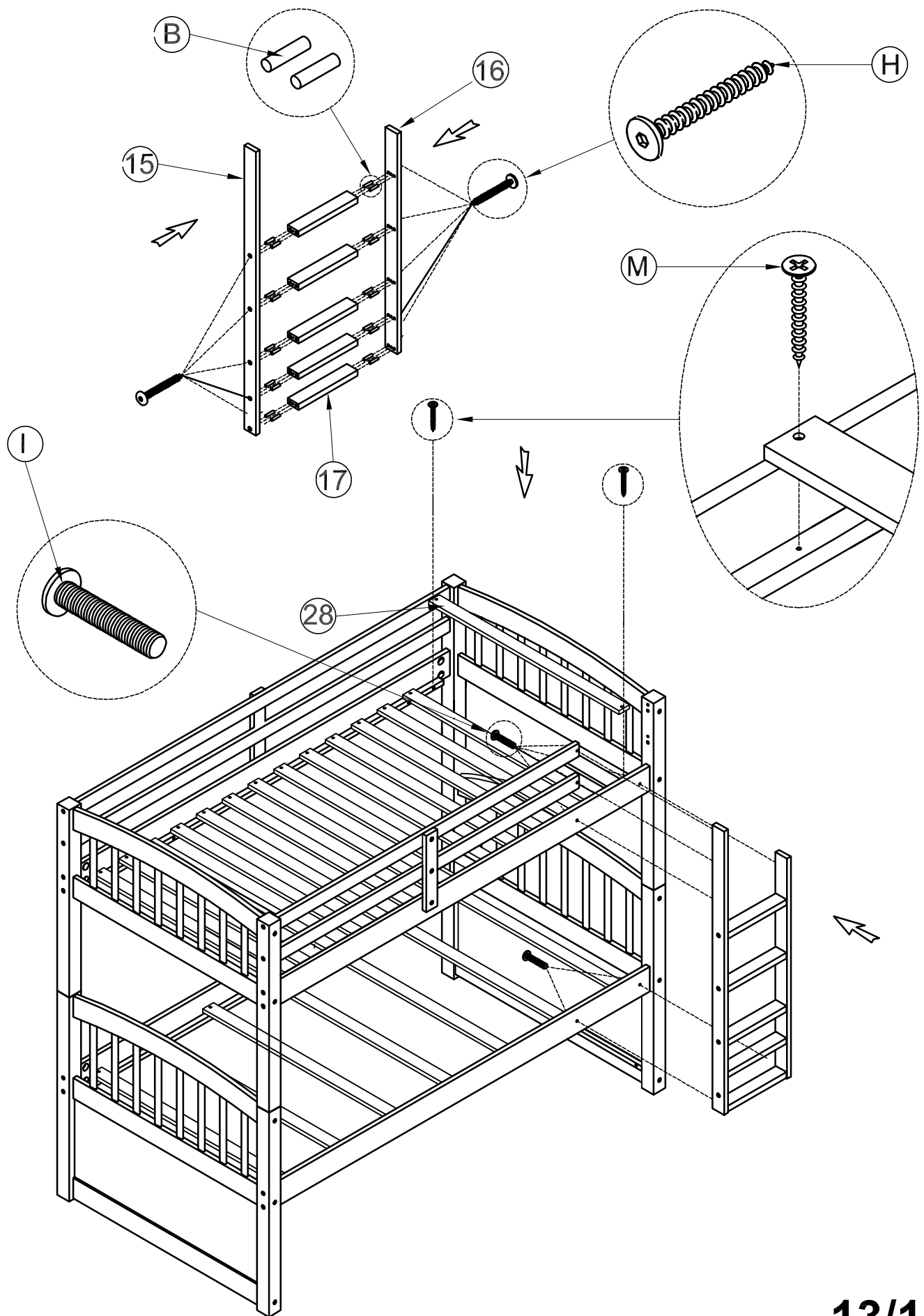

STEP 8:

Étape 8:

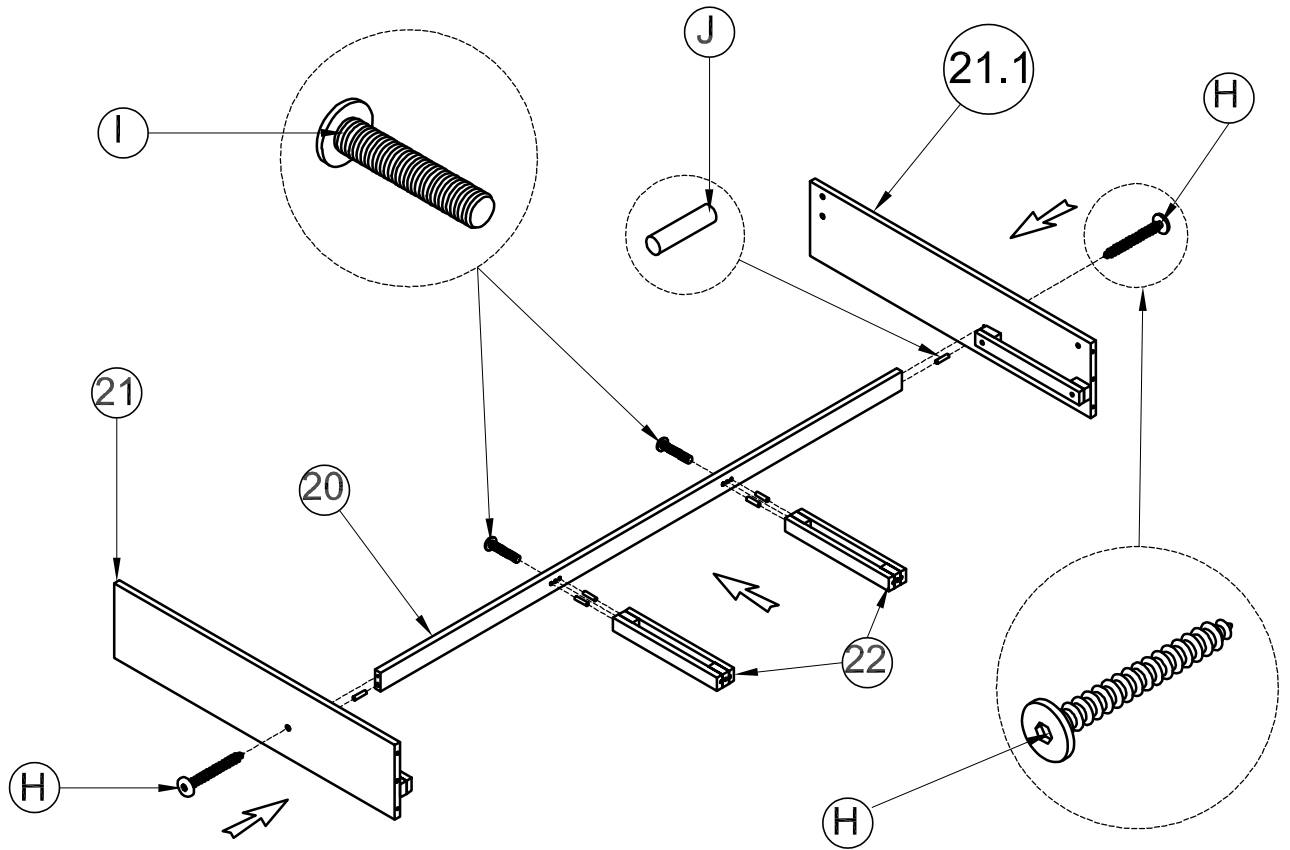

STEP 9:

Étape 9:

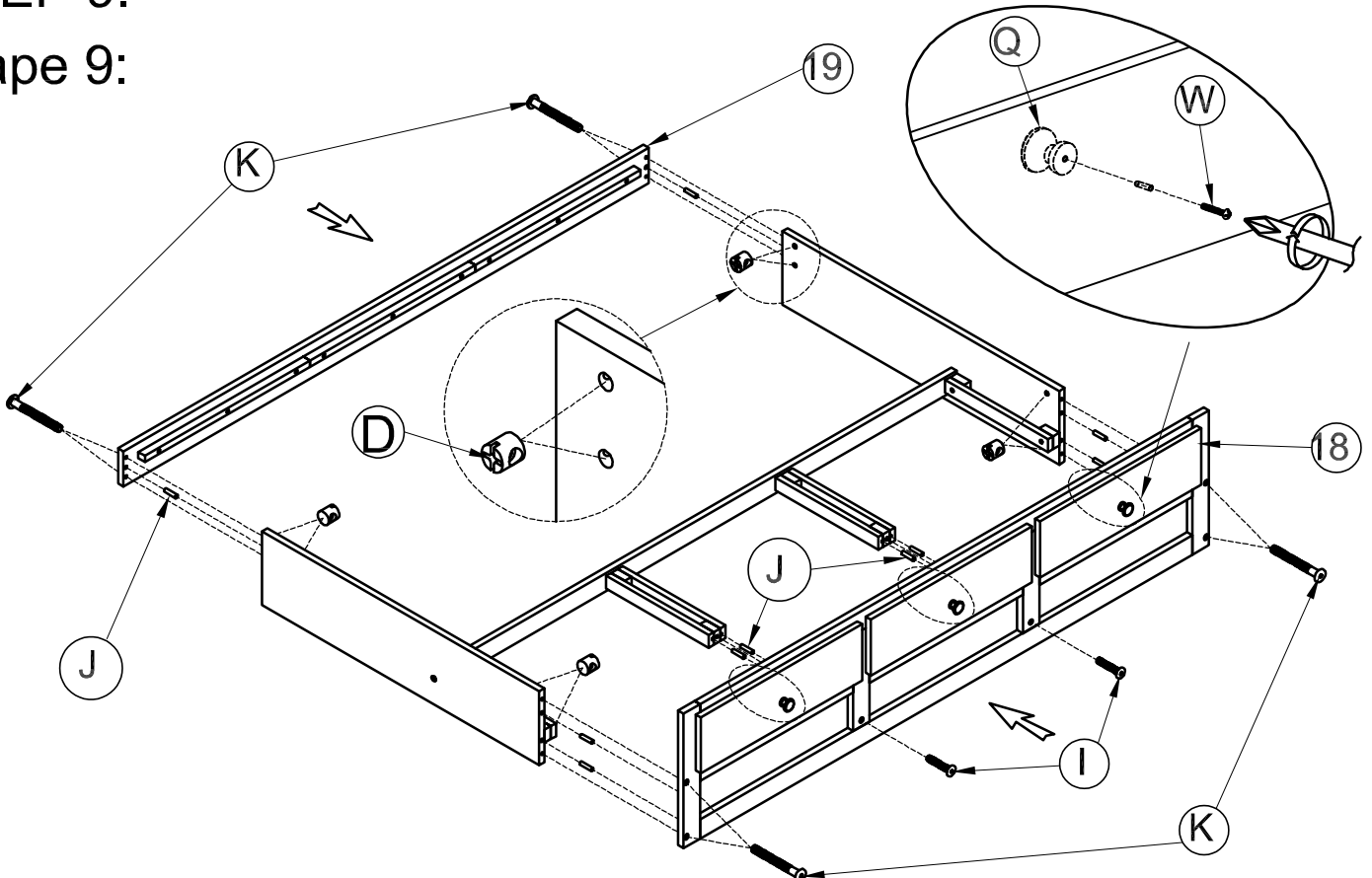

STEP 10:

Étape 10:

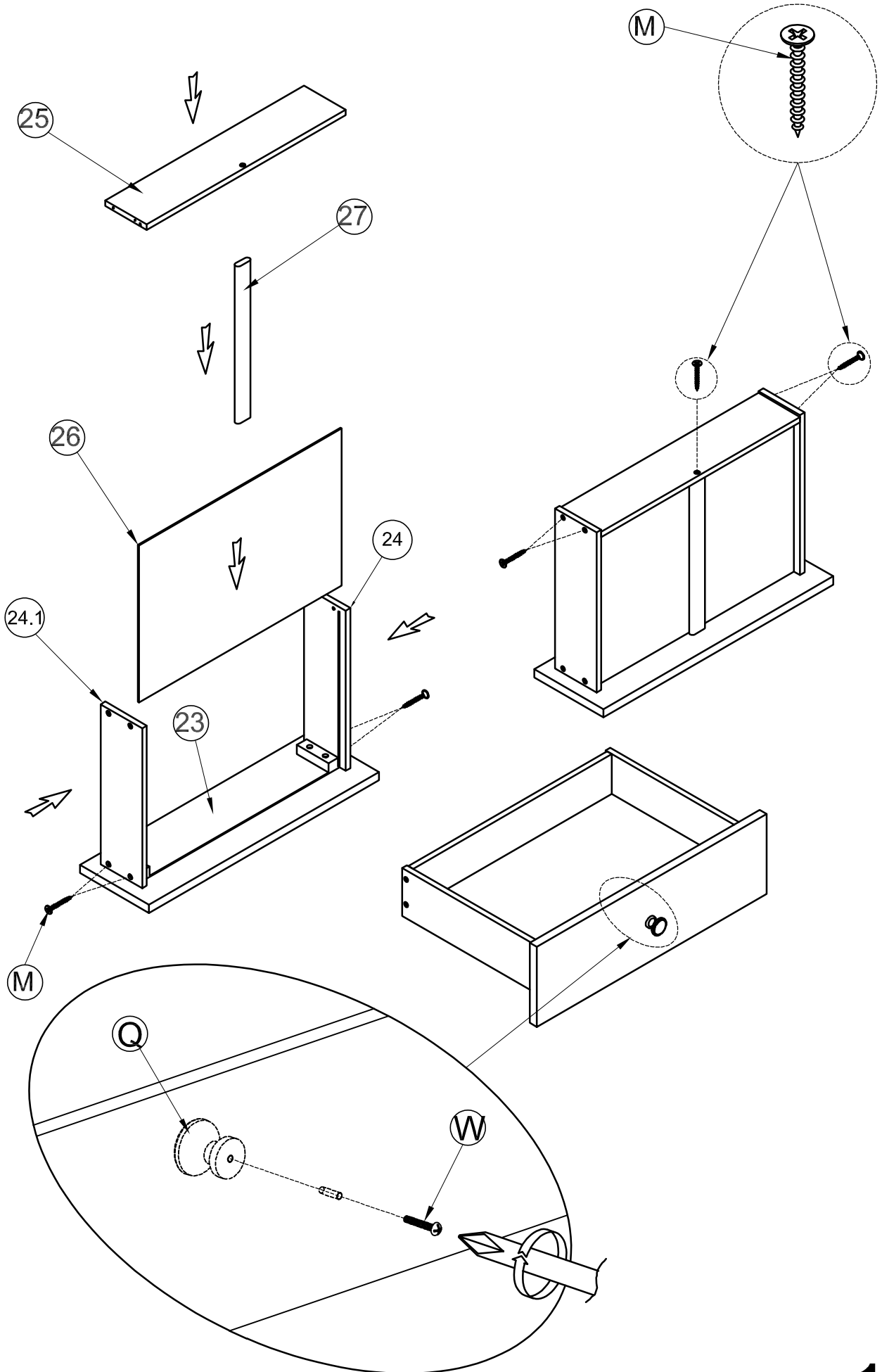

STEP 11:

Étape 11:

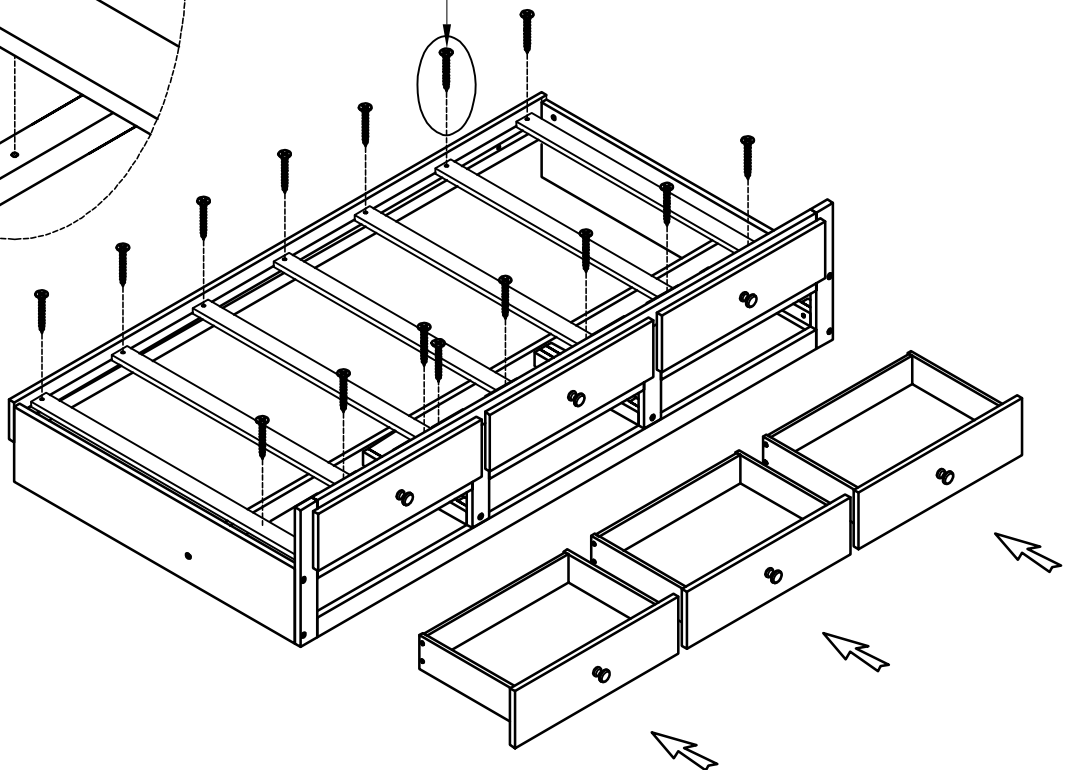
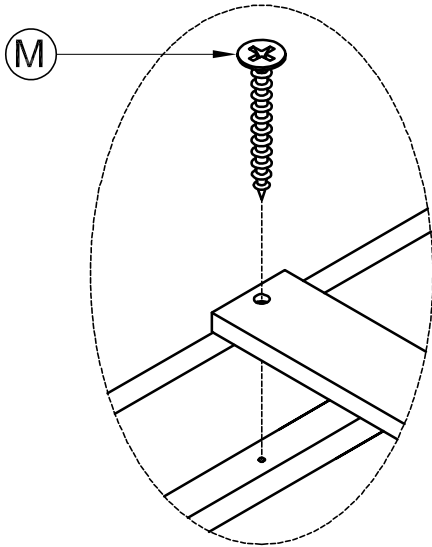
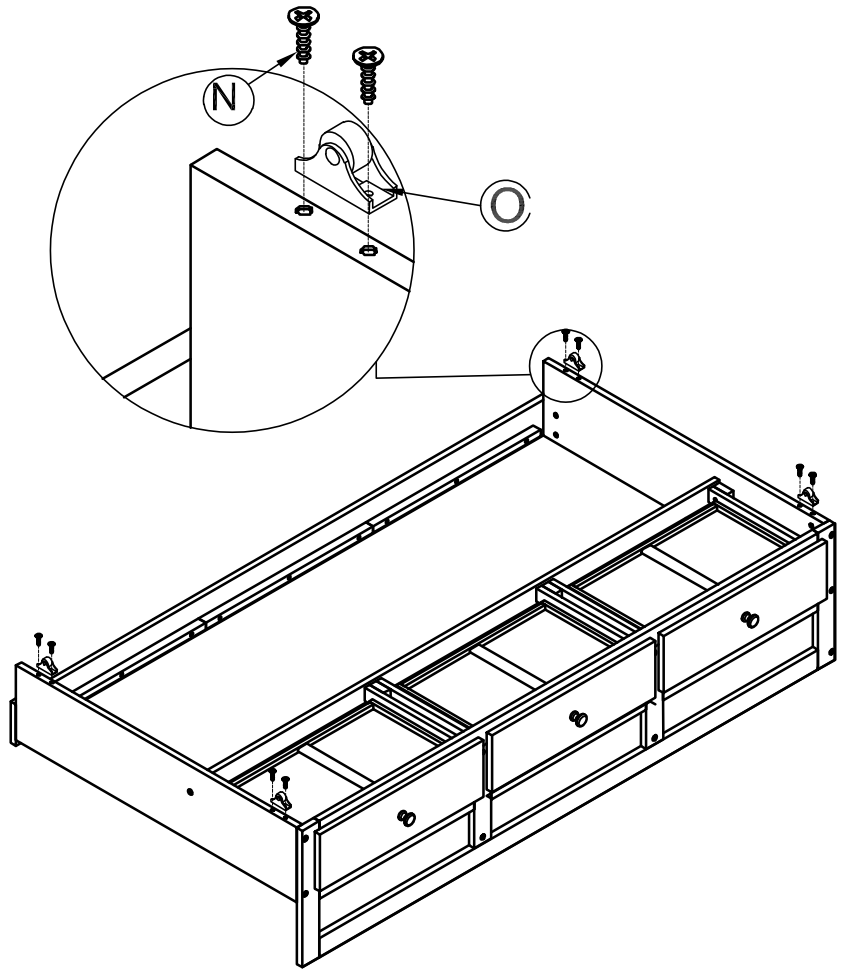

STEP 12:

Étape 12:

