

WF300681//WF300682

ASSEMBLY INSTRUCTION

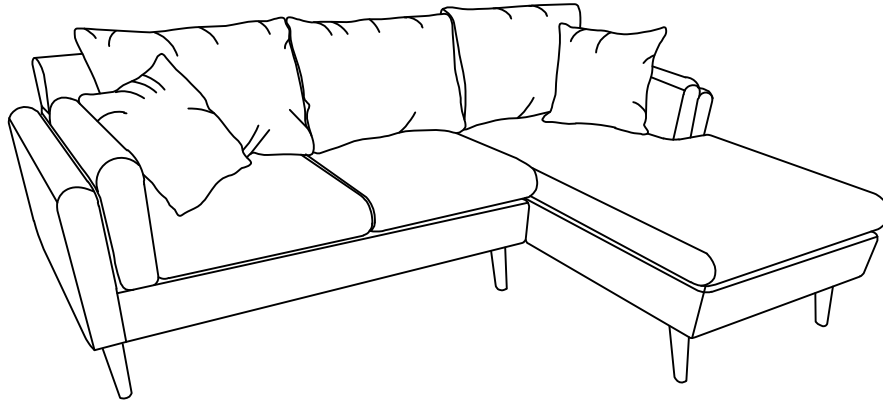

WF300682

WF300681

PARTS

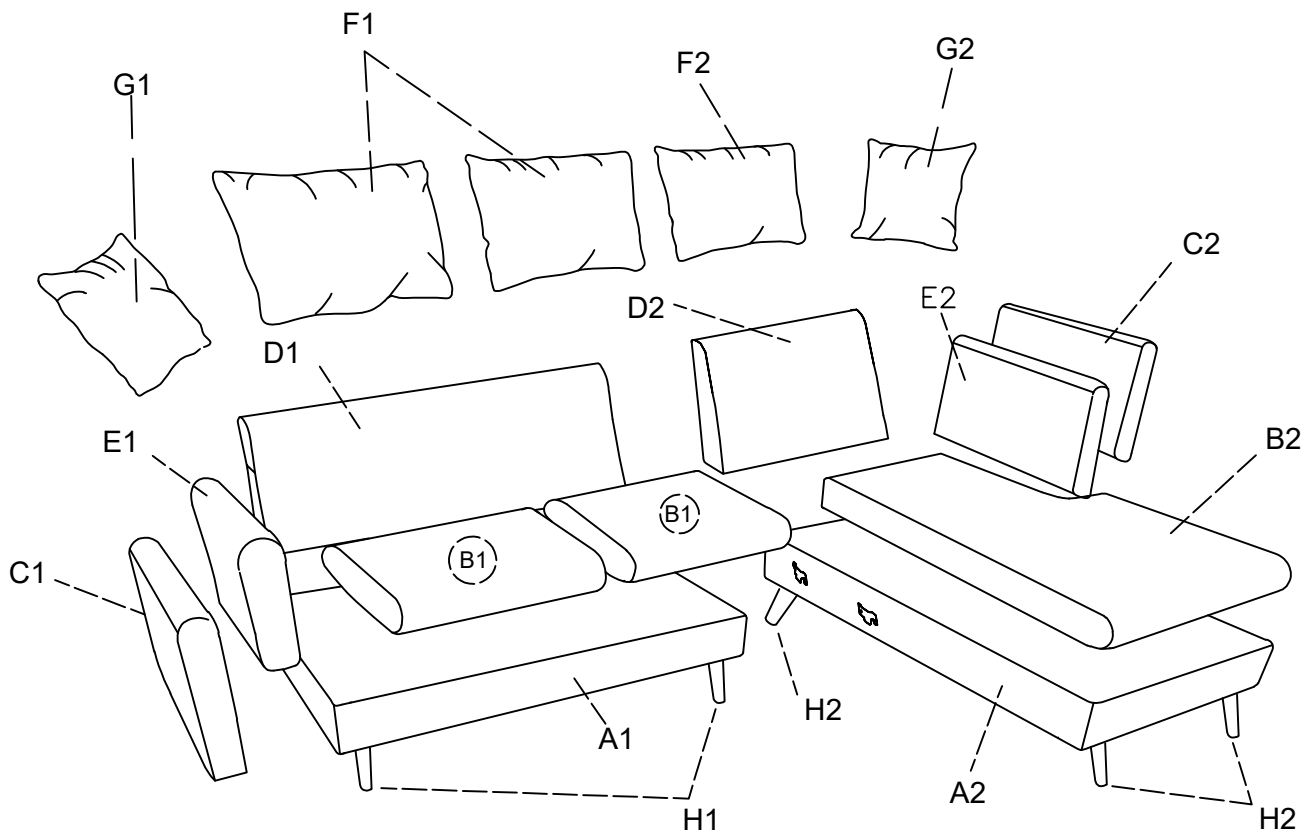

PART LIST

WF300682

A1

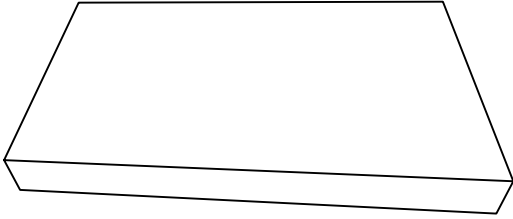

Loveseat Frame x 1

E1

E2

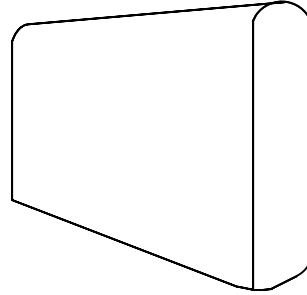

Side Rest x2

C1

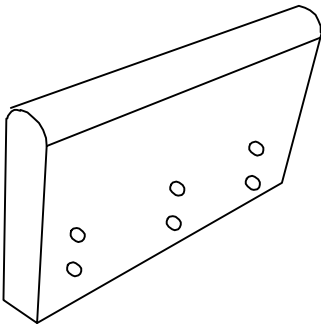

Side Frame x 1

D2

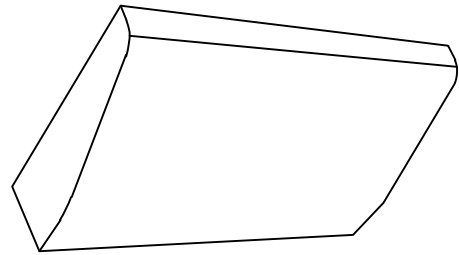

Back Frame x 1

D1

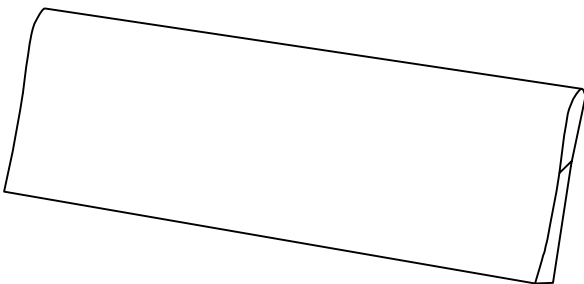

Back Frame x 1

I



Center Leg x 1

H1



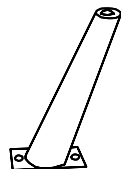





H2

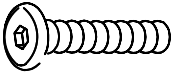

Leg x 8

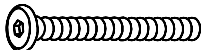
HARDWARE LIST

WF300682

<p>①</p>  <p>Bolts 5/16"*25mm x 16</p>	<p>②</p>  <p>Spring washer 5/16"*13mm*1.5mm x 16</p>	<p>③</p>  <p>Flat Washer 5/16"*19mm*1.5mm x 16</p>	<p>④</p>  <p>Allen Key 5mm*60mm x 1</p>
<p>⑤</p>  <p>Bolts 1/4"*50mm x 24</p>	<p>⑥</p>  <p>Spring washer 1/4"*11mm*1.5mm x 24</p>	<p>⑦</p>  <p>Flat Washer 1/4"*16mm*1.5mm x 24</p>	<p>⑧</p>  <p>Allen Key 4mm*60mm x 1</p>

Step 1: Place the Loveseat Frame upside down. Unwrap the lining fabric to take out the part as show below:

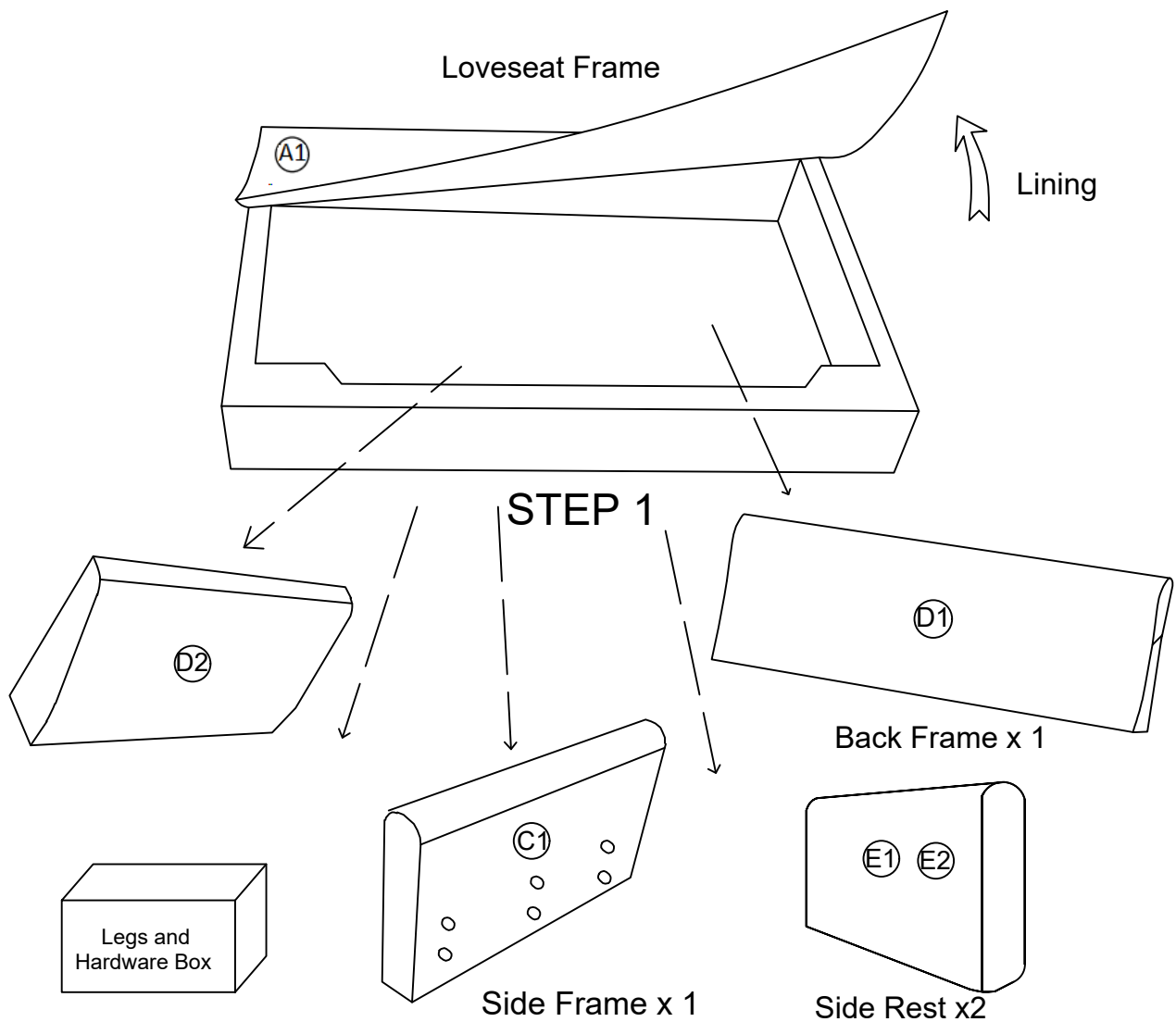

LOVESEAT FRAME

WF300682

Step 2: Unbox the legs and hardware out of the box. Aligned the leg (H1), tighten the bolt (1) with-in the flat washer (3) and spring washer (2). Clockwise turning by allen key (4), do not over tight. Repeat same method till all legs assembled.

Step 3: Turning the center leg (I) to the frame.

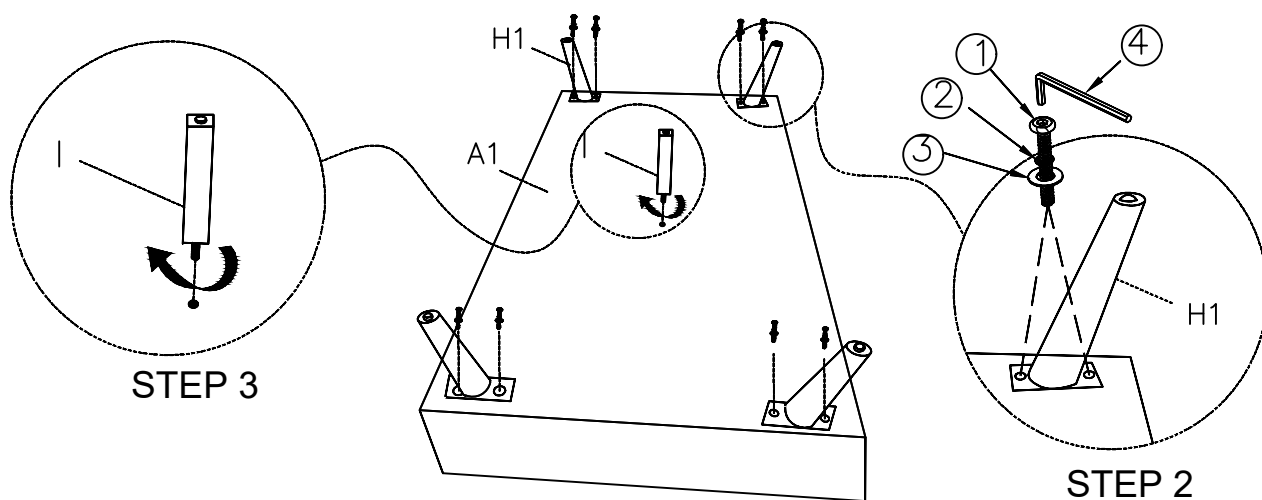

Step 4: Aligned the side frame (C1) and back frame (D1), tighten the bolt (5) with-in the flat washer (7) and spring washer (6), Clockwise turning by allen key (8), do not over tight.

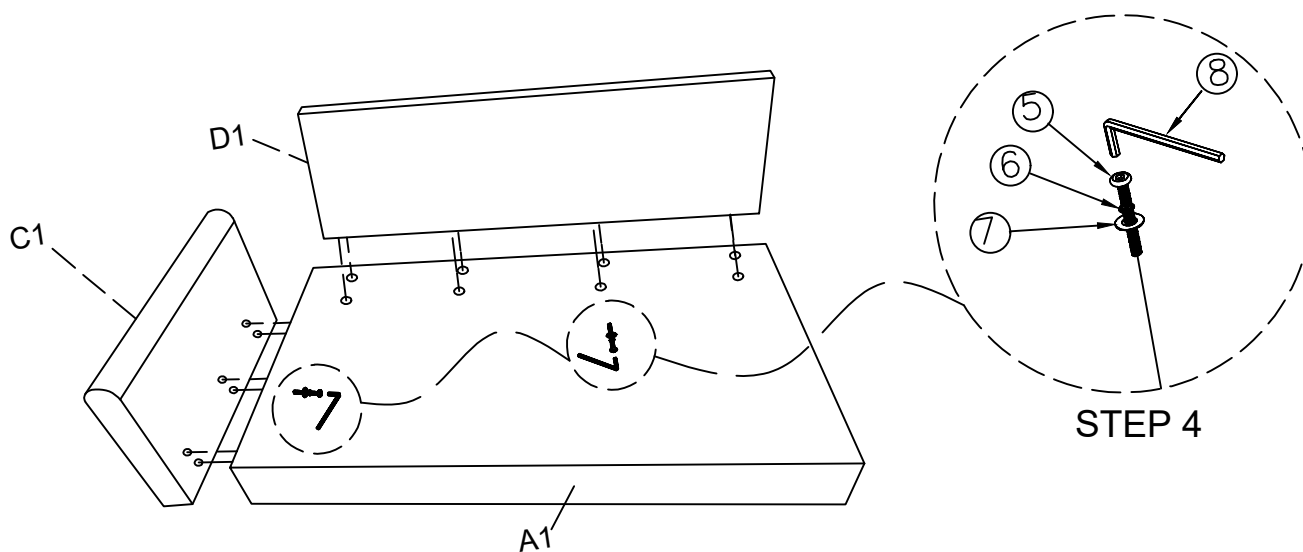

PART LIST

WF300681

A2

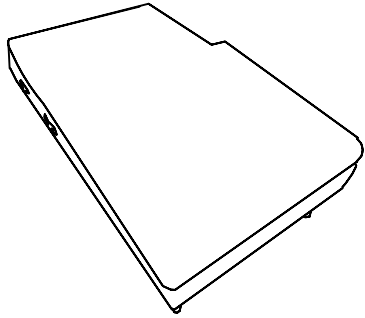

Seat Frame x 1

C2

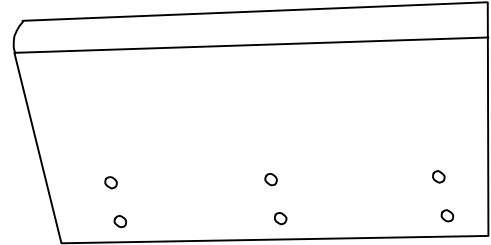

Side Frame x 1

B2

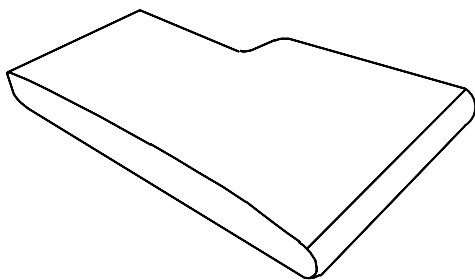

Seat Cushion x 1

F1
F2

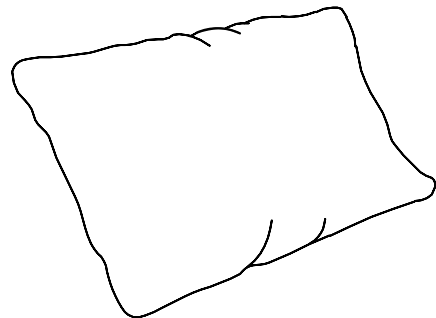

Back Pillow x3
(F1 x 2pcs; F2 x 1pc)

B1

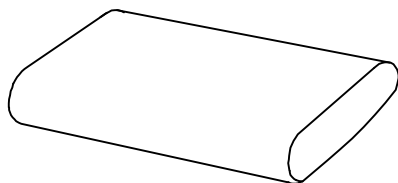

Seat Cushion x 2

G1
G2

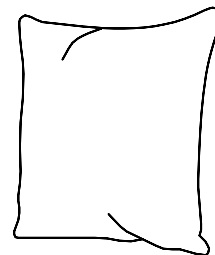

Pillow x2

HARDWARE LIST

WF300681

Step 1: Place the Seat Frame upside down. Unwrap the lining fabric to take out the parts as show below:

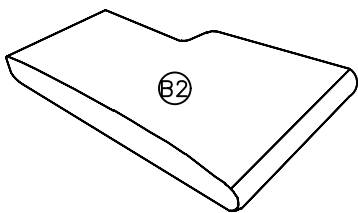
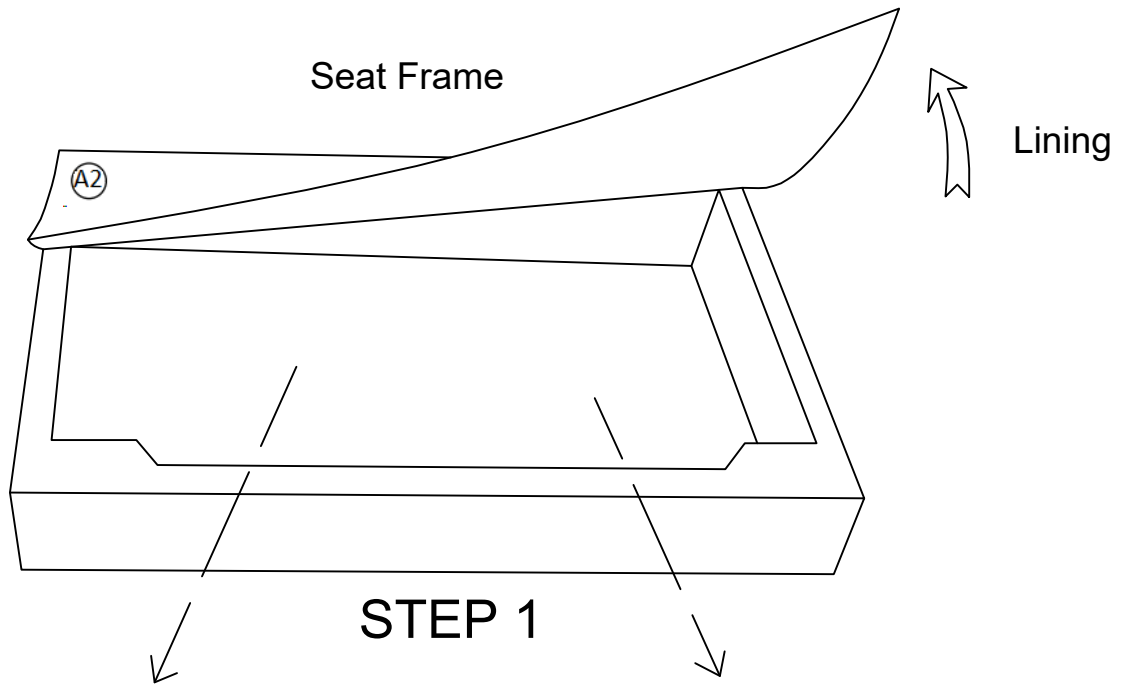

Seat Cushion x 1

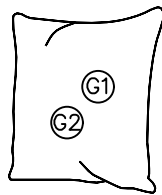

Pillow x 2

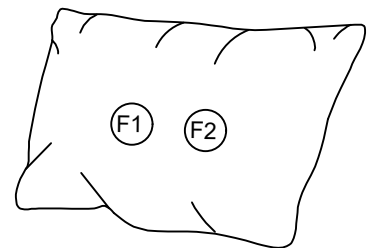

Back Pillow x 3

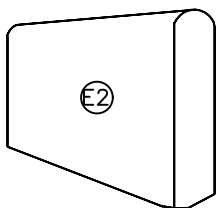

Side Rest x 1

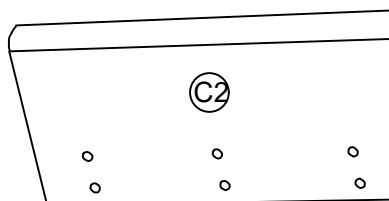

Side Frame x 1

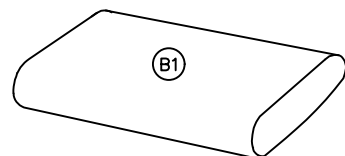

Seat Cushion x 2

SEAT FRAME

WF300681

Step 2: Aligned the leg (H2), tighten the bolt (1) with-in the flat washer (3) and spring washer (2), Clockwise turning by allen key (4), do not over tight. Repeat same method till all legs assembled.

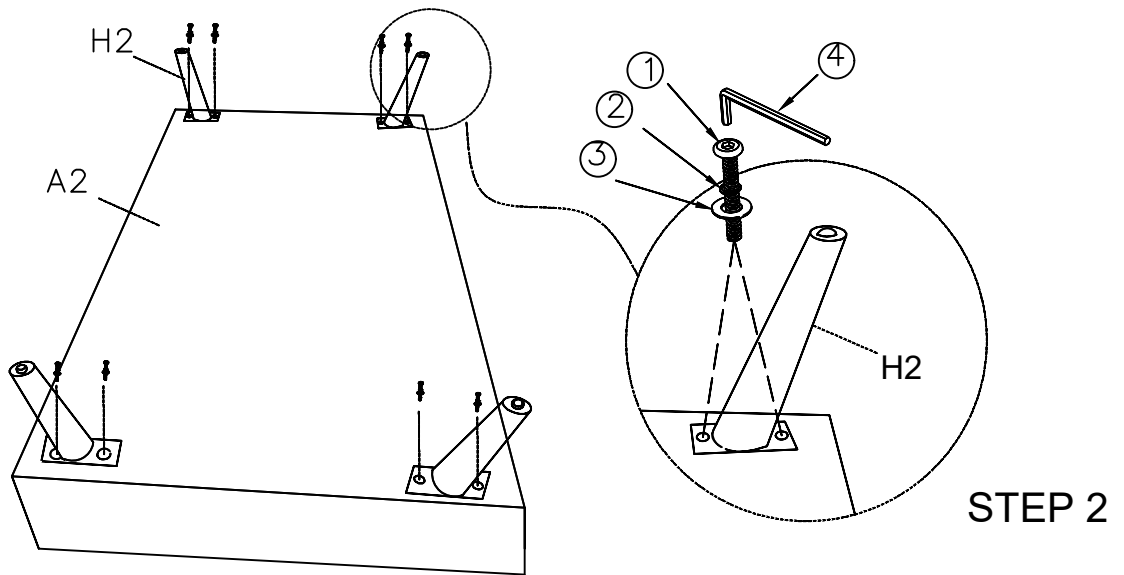

Step 3: Aligned the side frame (C2) and back frame (D2), tighten the bolt (5) with-in the flat washer (7) spring washer (6). Clockwise turning by allen key (8), do not over tight.

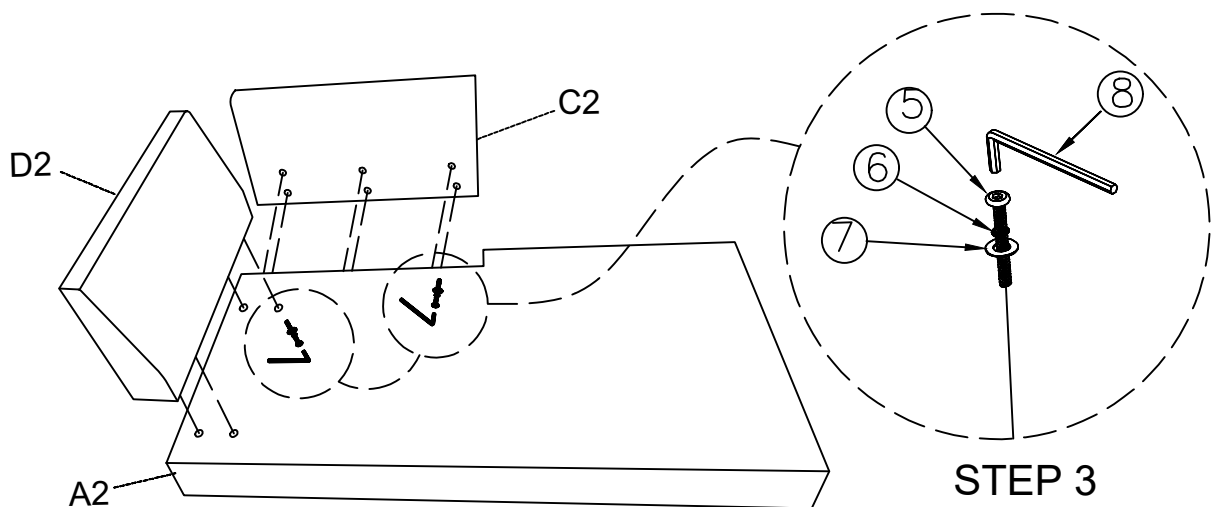

COMPLETE

WF300681 & WF300682

Connect WF300681 and WF300682 by the 2 sets bracket attached, as diagram shown

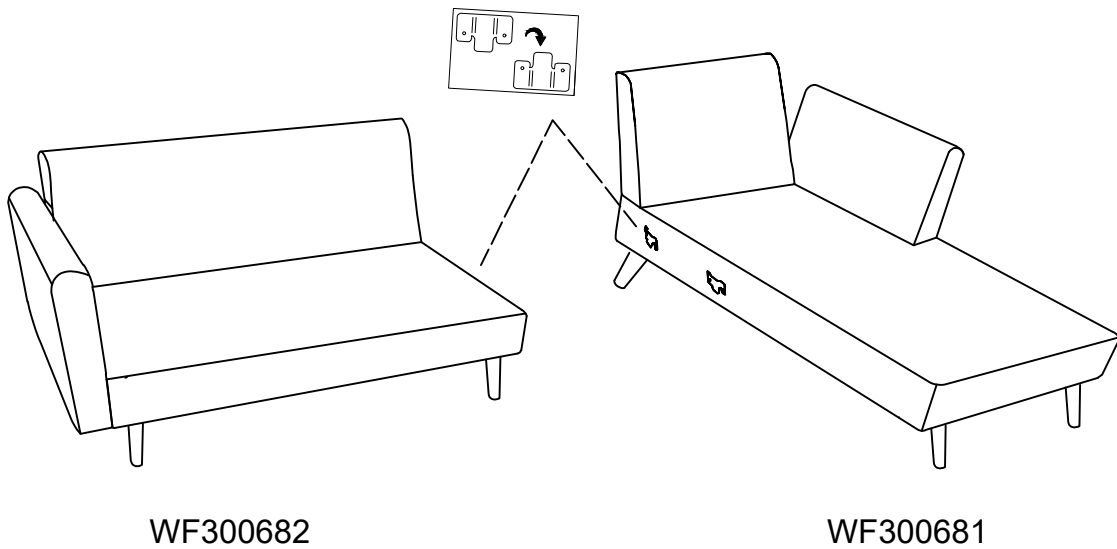

Complete: Insert Seat Cushion (B1, B2) to the Seat frame as shown.
Place Side Rest (E1, E2) and Pillow (G1, G2) on the Side frame.
Place Back Pillow (F1, F2) on the Back frame.

