

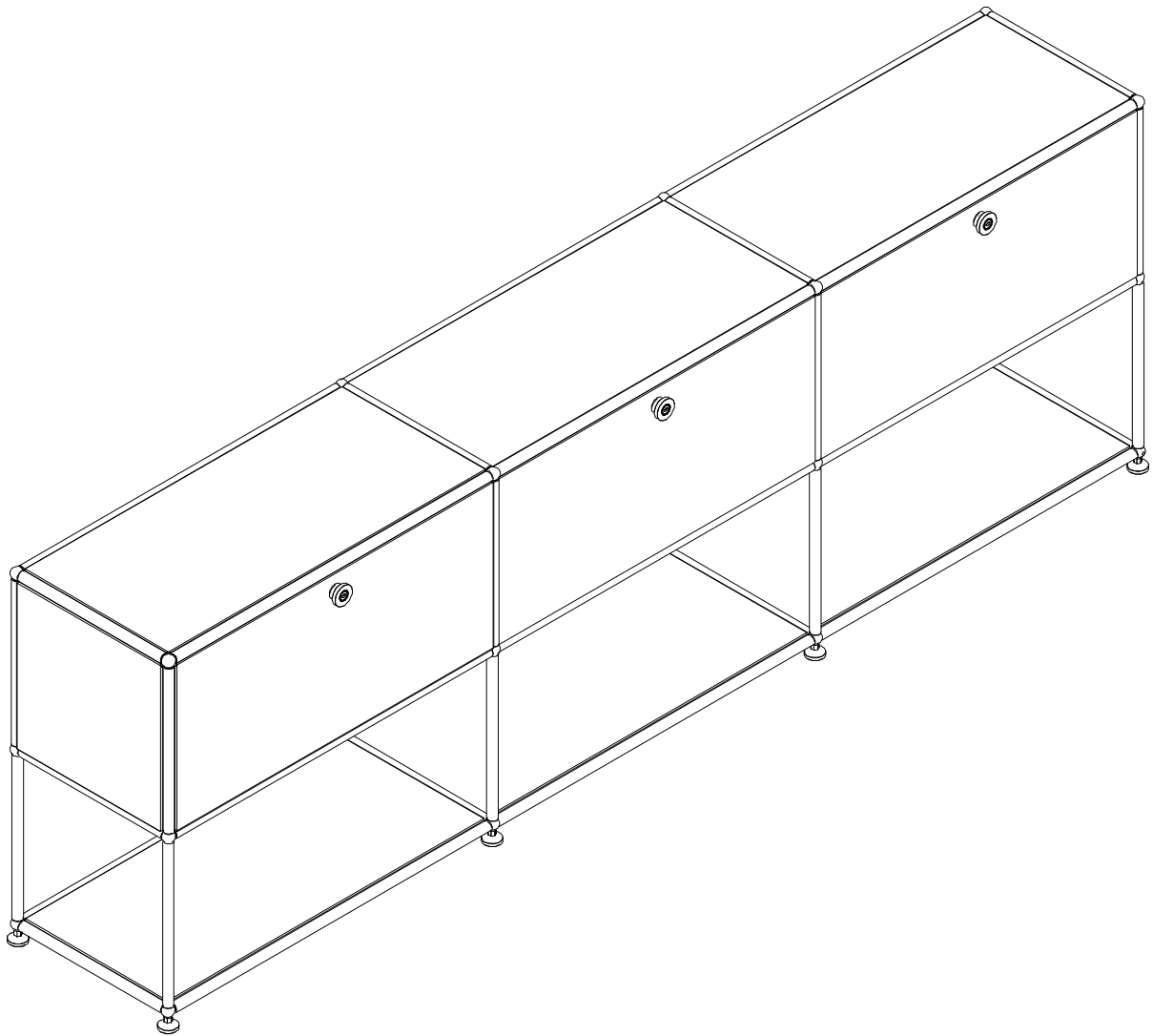

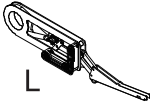

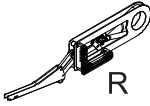

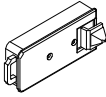

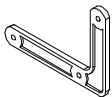
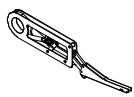

ASSEMBLY INSTRUCTIONS

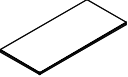

Storage Cabinets Type G

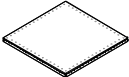
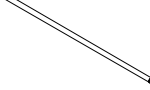

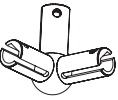
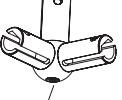
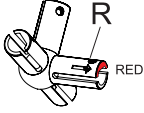
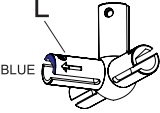

Part List

①	②	③	④	⑤	⑥	⑦	⑧
							
x1	x3	x3	x2	x2	M3x28 x6	M4x25 x6	M4x14 x6

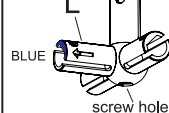
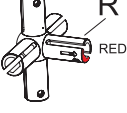
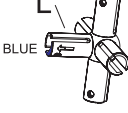
A	B	C	D	E1	E2	F	G
							
x12	x3	x2	x2	Long x18	Short x28	x3	x8

H1	H2	J1	J2	K1	K2	L1	L2
							
x4	x4	x4	x4	x2	x2	x2	x2

M	N	II
		
x92	x1	x1

Step1

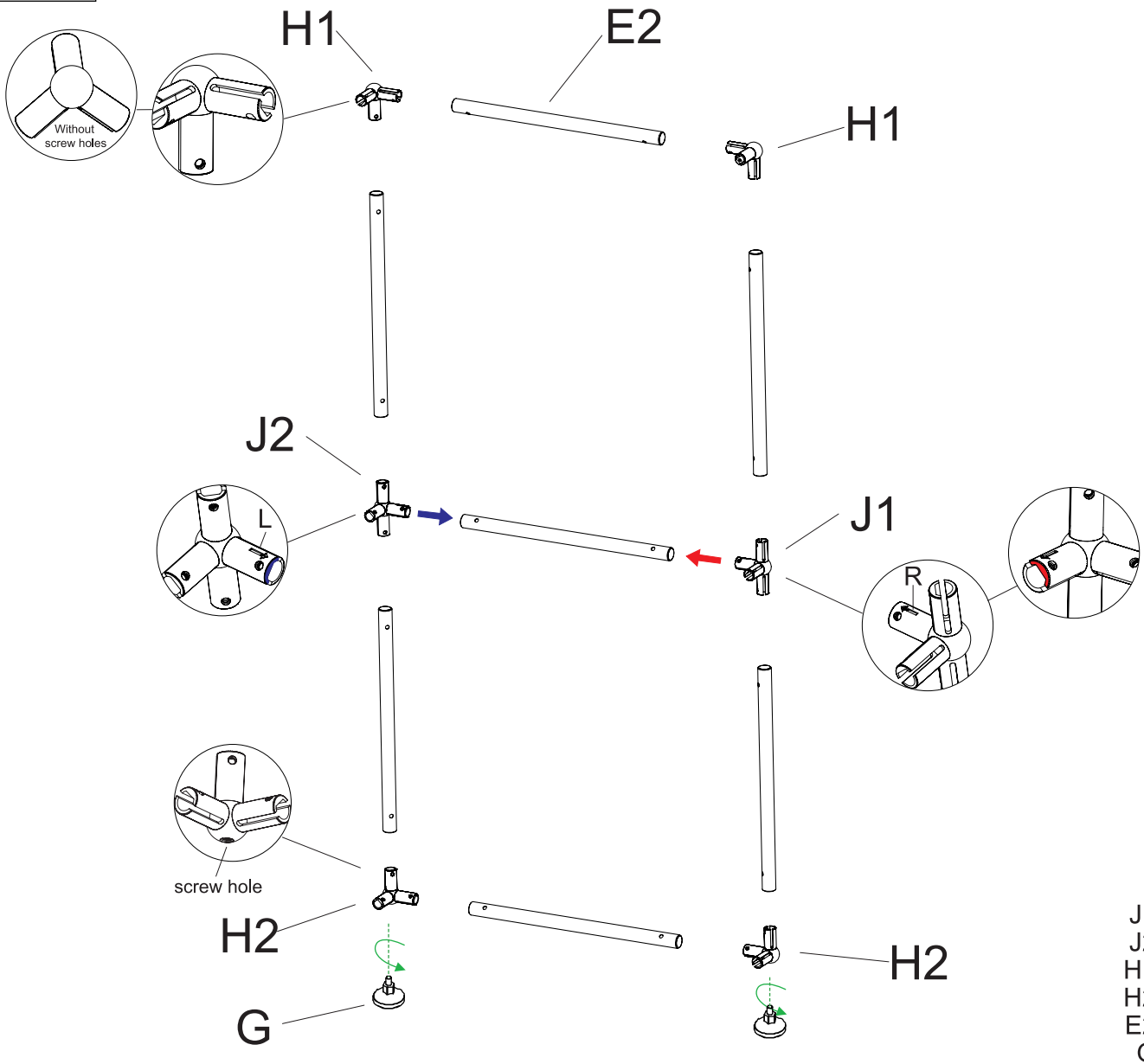

- J1x1
- J2x1
- H1x2
- H2x2
- E2x7
- Gx2

Step2

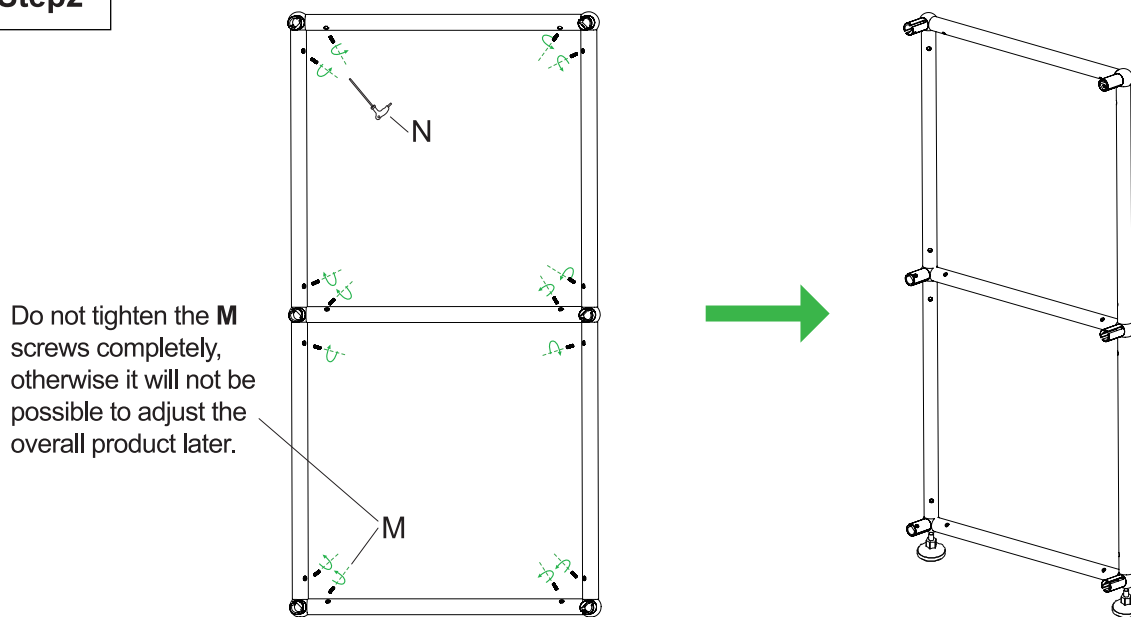

Do not tighten the **M** screws completely, otherwise it will not be possible to adjust the overall product later.

- Mx14
- Step2x2

Step3

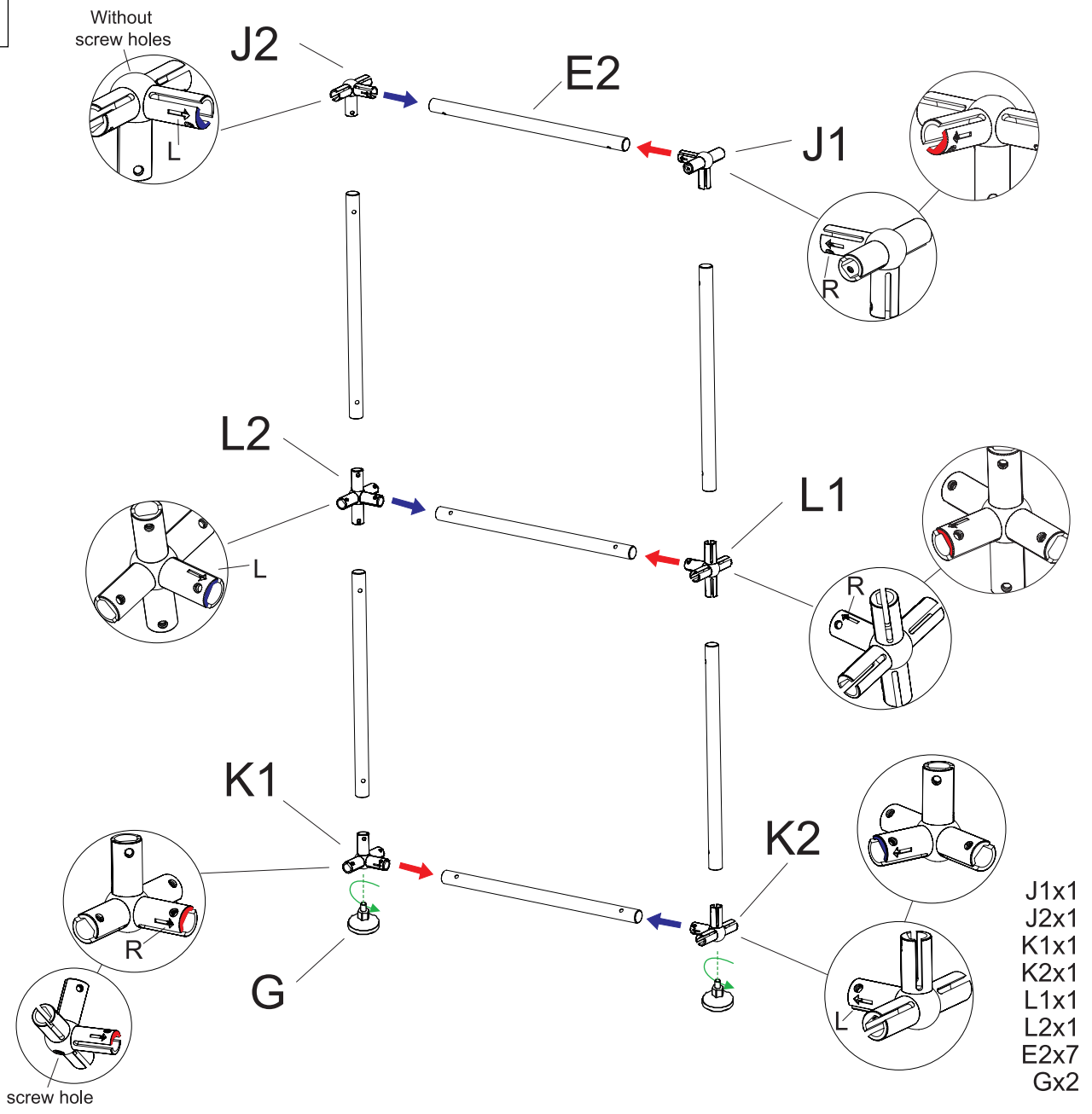

Step4

Do not tighten the **M** screws completely, otherwise it will not be possible to adjust the overall product later.

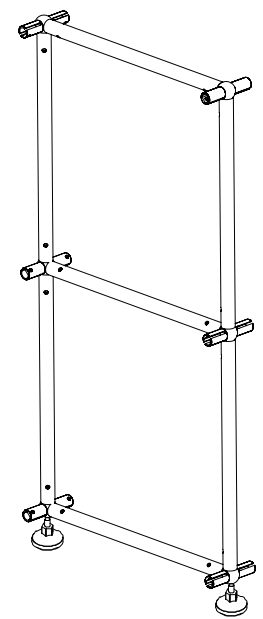
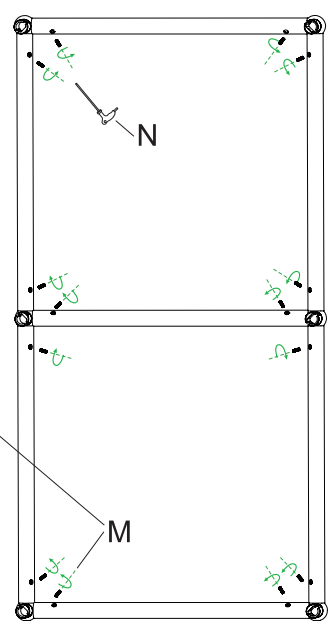

Mx14
Step4x2

Step5

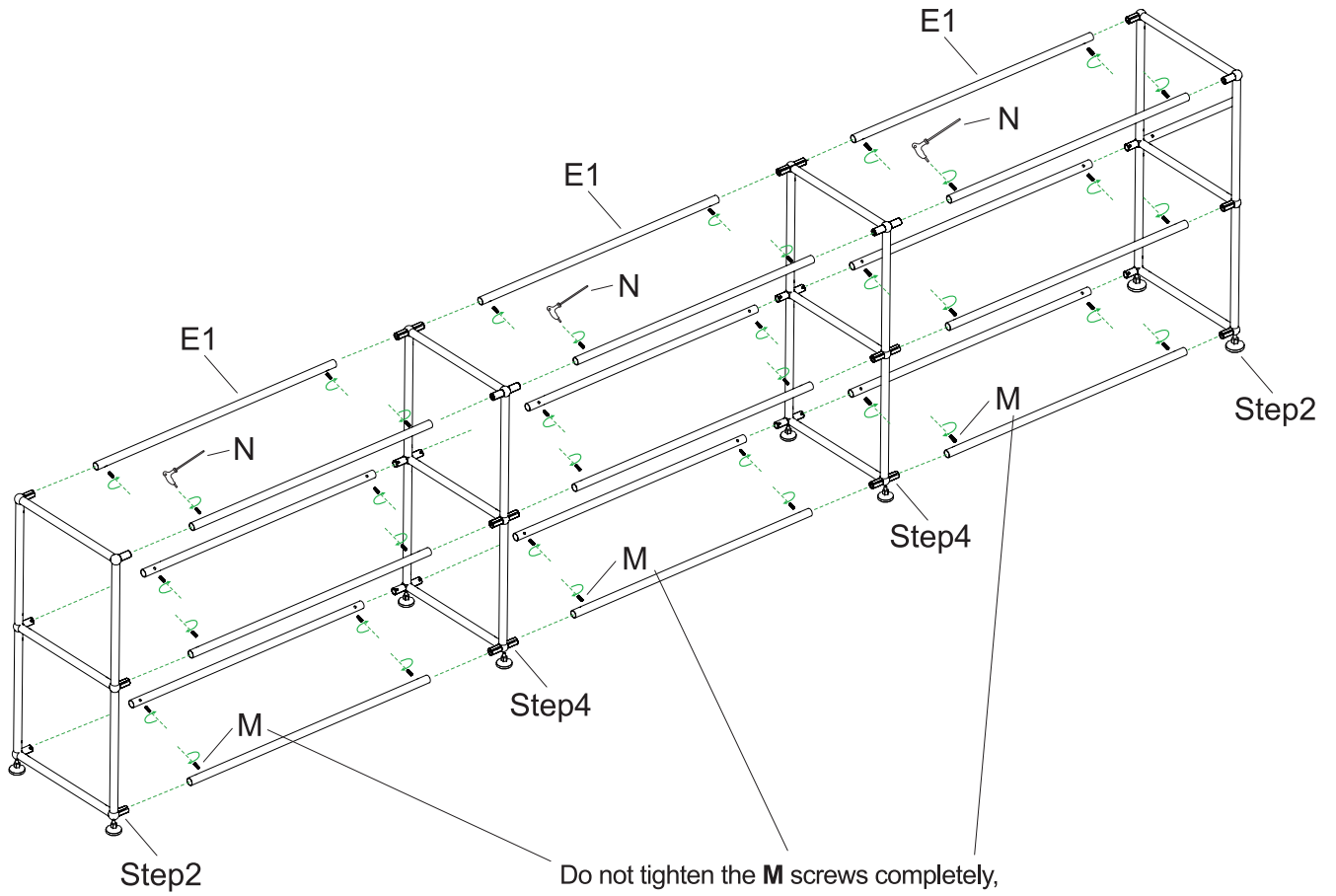

Step6

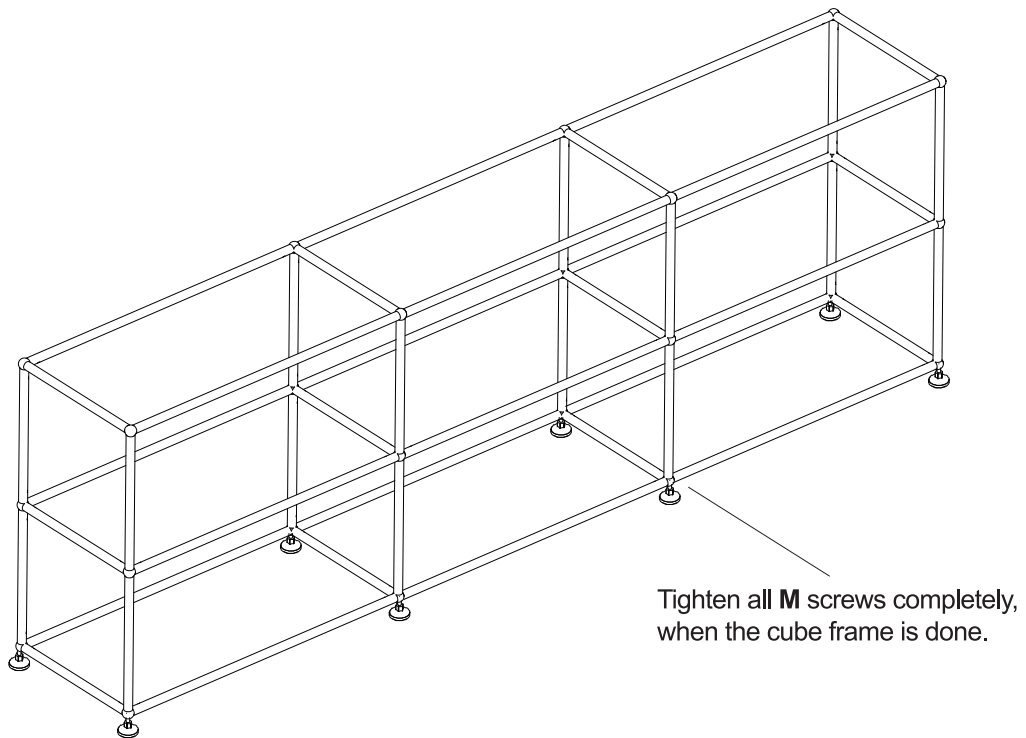

Step7

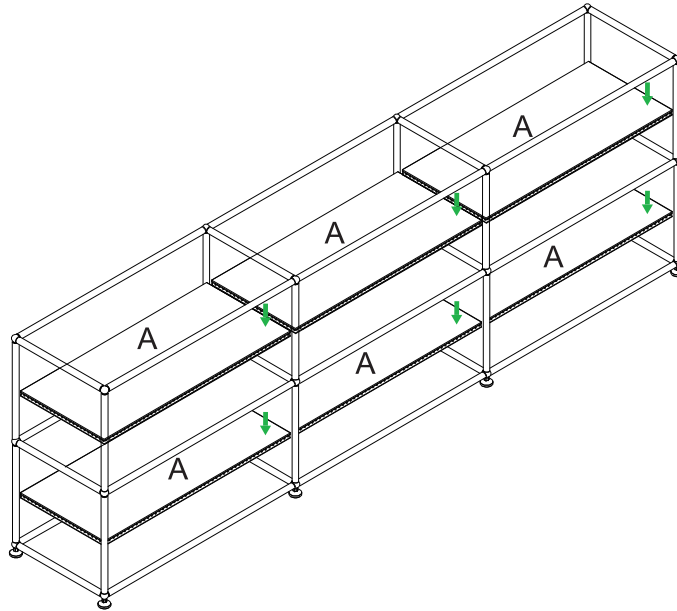

Ax6

Step8

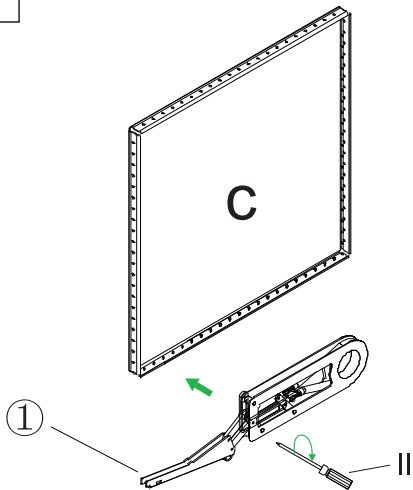

Partially unscrew the three screws in ① before installing it on the metal panel.

Cx1
①x1
Step8x1

Step9

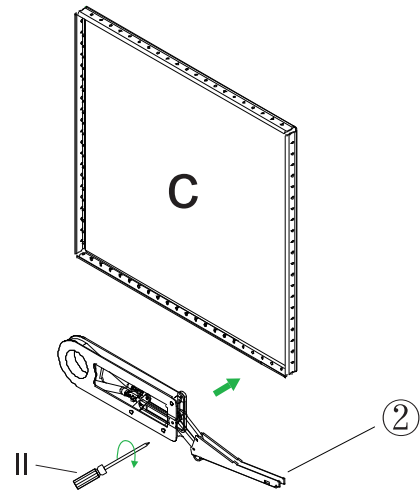

Partially unscrew the three screws in ② before installing it on the metal panel.

Cx1
②x1
Step9x1

Step10

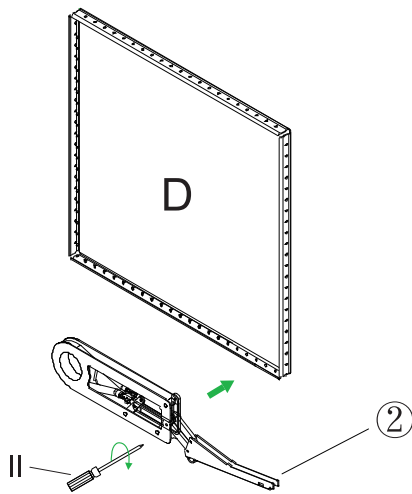

Partially unscrew the three screws in ② before installing it on the metal panel.

Dx1
②x1
Step10x2

Step11

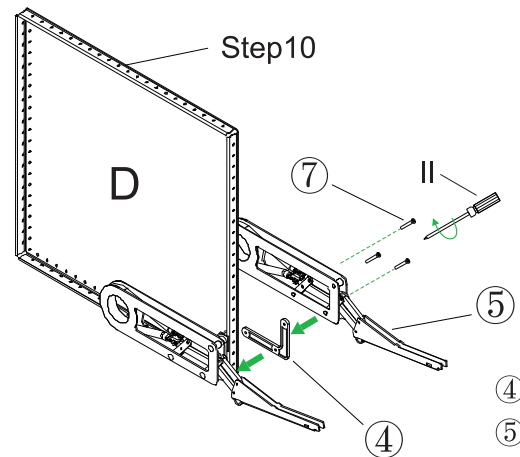

④x1
⑤x1
⑦x3
Step10x1
Step11x2

Step12

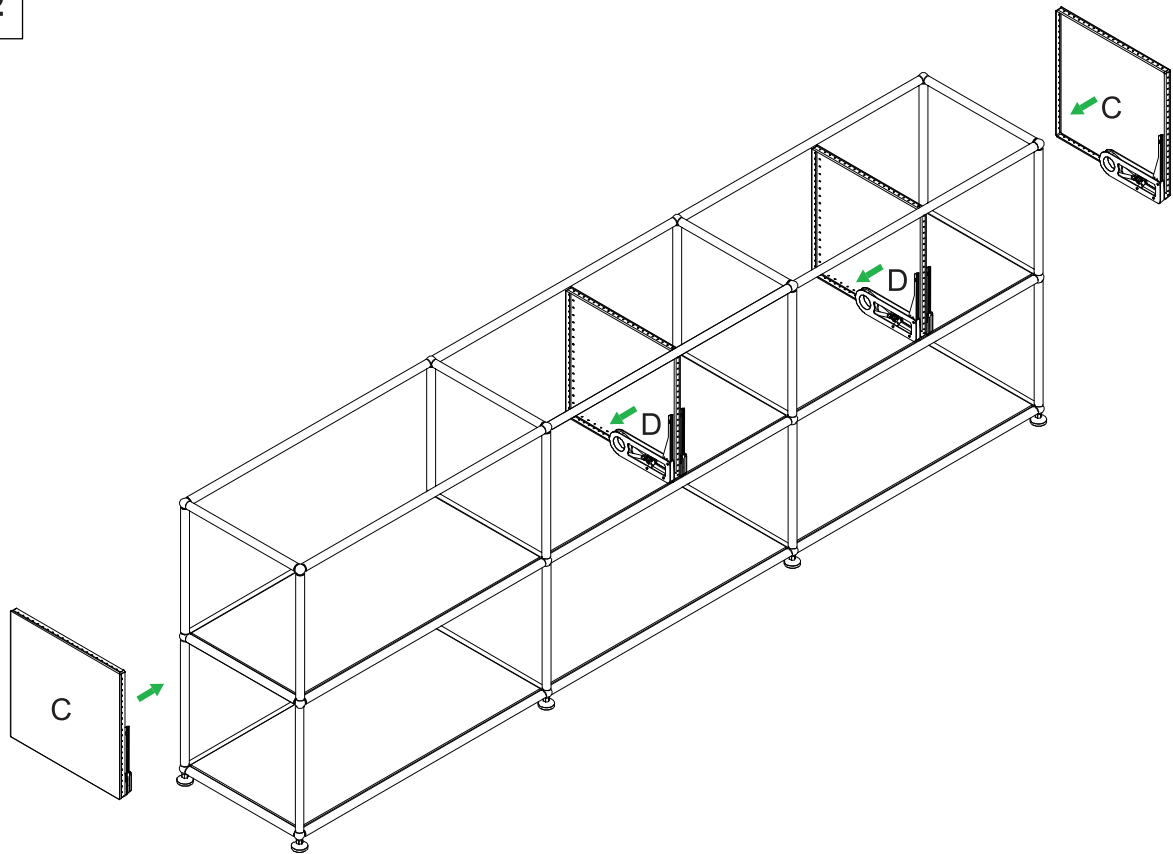

Step8x1
Step9x1
Step11x2

Step13

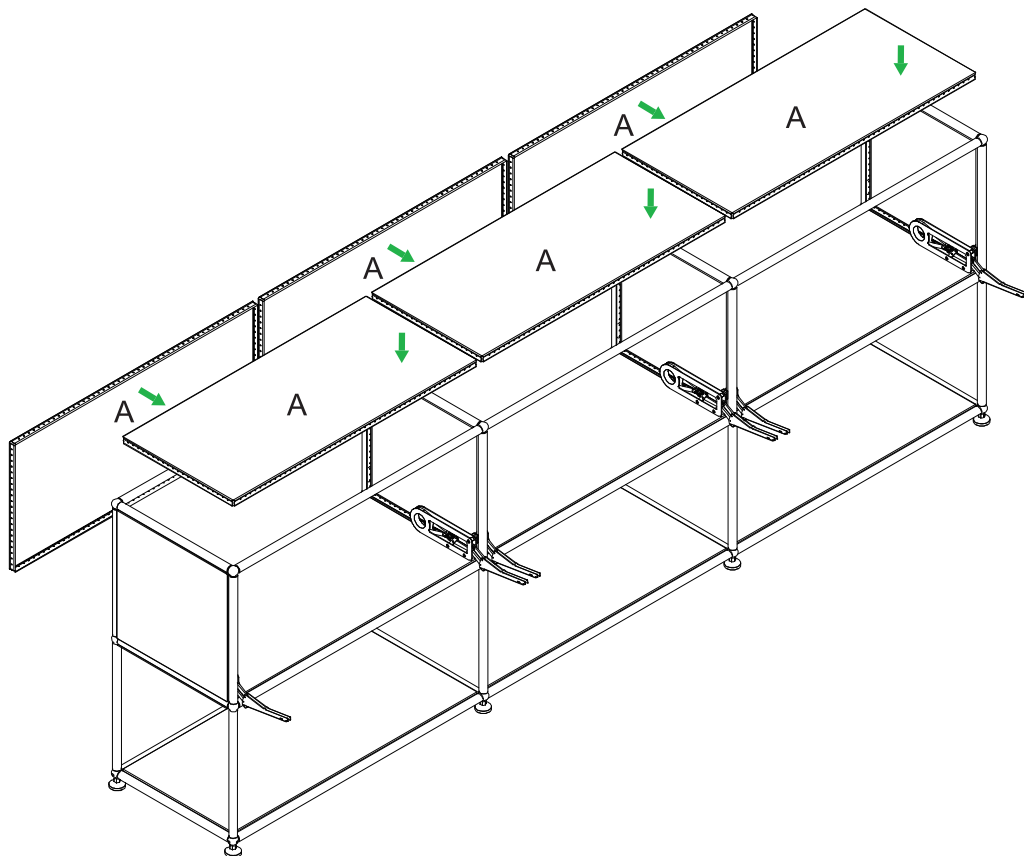

Ax6

Step14

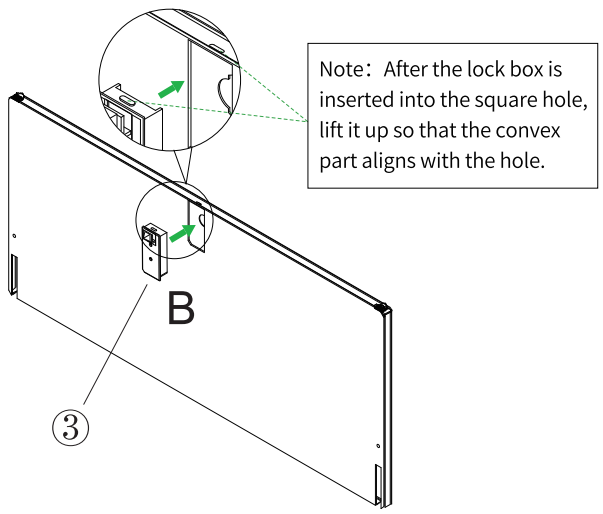

③x1
Bx1

Step15

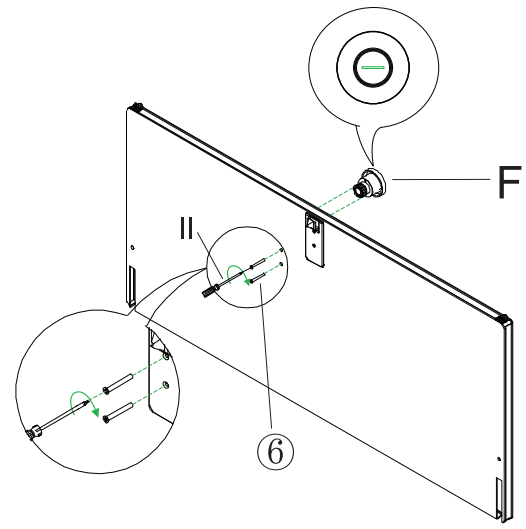

⑥x2
Fx1
Step15x3

Step16

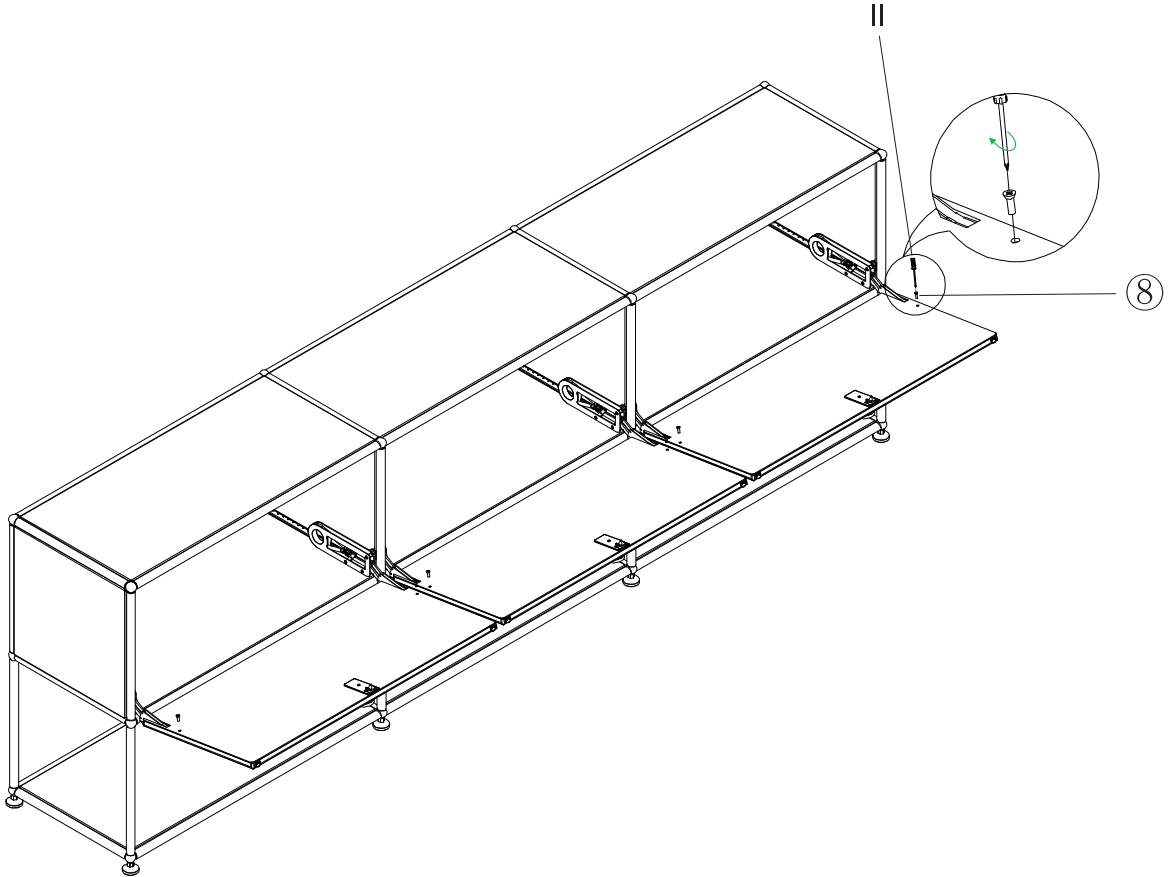

⑧x6

Finish

