

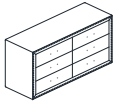





# ASSEMBLY INSTRUCTION

ITEM :

**BOX OF DRESSER  
DRESSER**

ITEM	DRAWING	DESCRIPTION	QTY
A		DRESSER	1
B		LEG	4
C		SUPPORT LEG (Located in the bottom drawer)	1
D		TIPPING RESTRAINT (Affix to wall behind dresser) *Located in the 1st right side front Drawer of the Dresser	1

**BOX OF DRESSER  
HARDWARE LIST**

ITEM	DRAWING	DESCRIPTION	QTY
1		JCBC SCREW M6x20mm	8
2		L-KEY M4x65mm	1

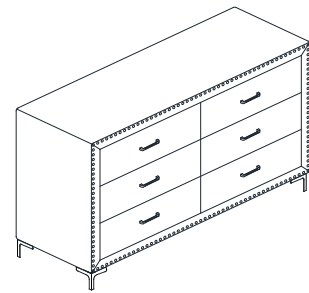

COMPLETED DRESSER ASSEMBLY

**STEP 1**

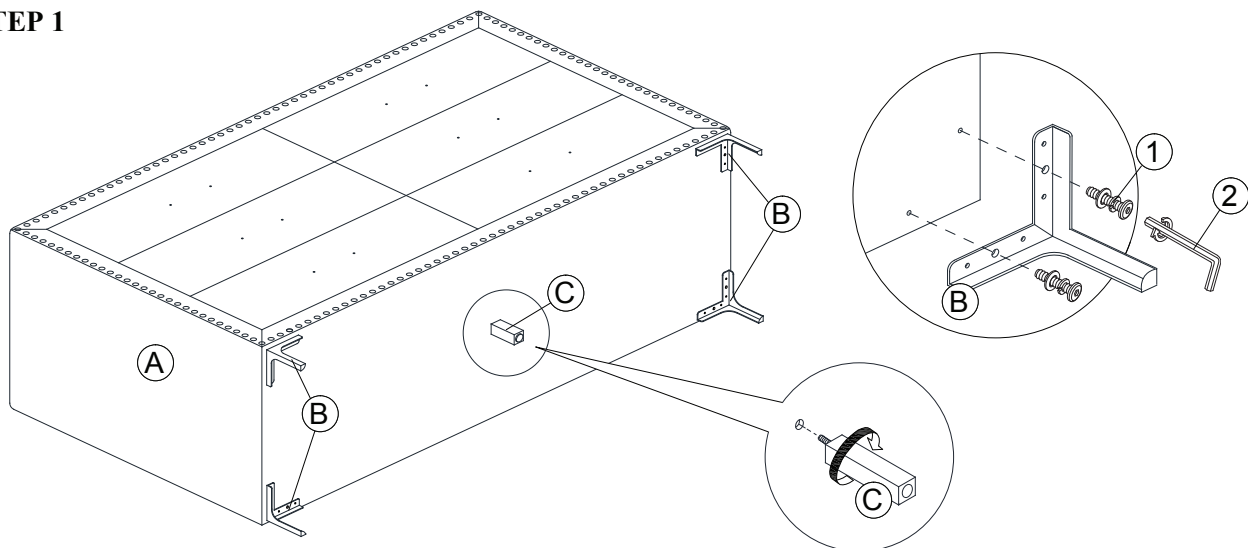

**STEP 2**

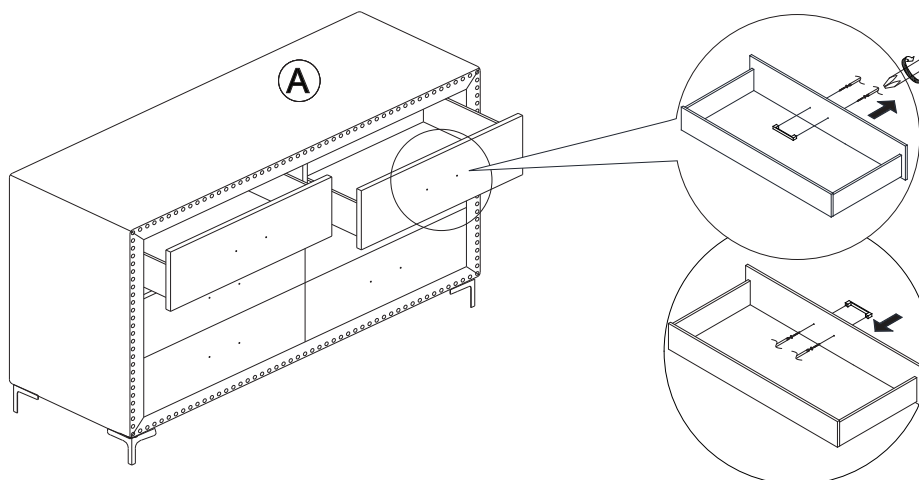

THE HARDWARE ID LOCATED IN THE PACKING ITEMS

THE ANTI TIPPING HARDWARE IS LOCATED IN THE 1ST RIGHT SIDE FRONT DRAWER OF THE DRESSER.

NOTE : MUST TIGHT SCREWS PERIODICALL WITH USE SCREWS MAY BECOME LOOSE.  
CHECK TIGHTNESS OF ALL SCREWS EVERY 6-8 WEEKS.

**MADE IN MALAYSIA**