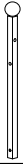

Photo Tree
(PY022101)

PARTS

Bracket ① x1



Bracket ② x2



Bracket ③ x1



Plank base ④ x1



Rotary ⑤ x1

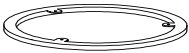

Small flat iron ⑥ x4

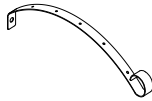

Large flat iron ⑦ x4

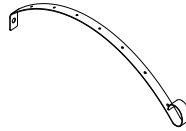

Photo clips ⑧ x30



A x3



M6*12mm Screw

B x4



M6*25mm Screw

C x4



Nuts

D x7



M4*15mm Screw

E x1

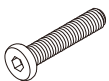

M6*40mm Screw



Allen Key x1



Wrench x1

HARDWARE

PARTS OVERVIEW

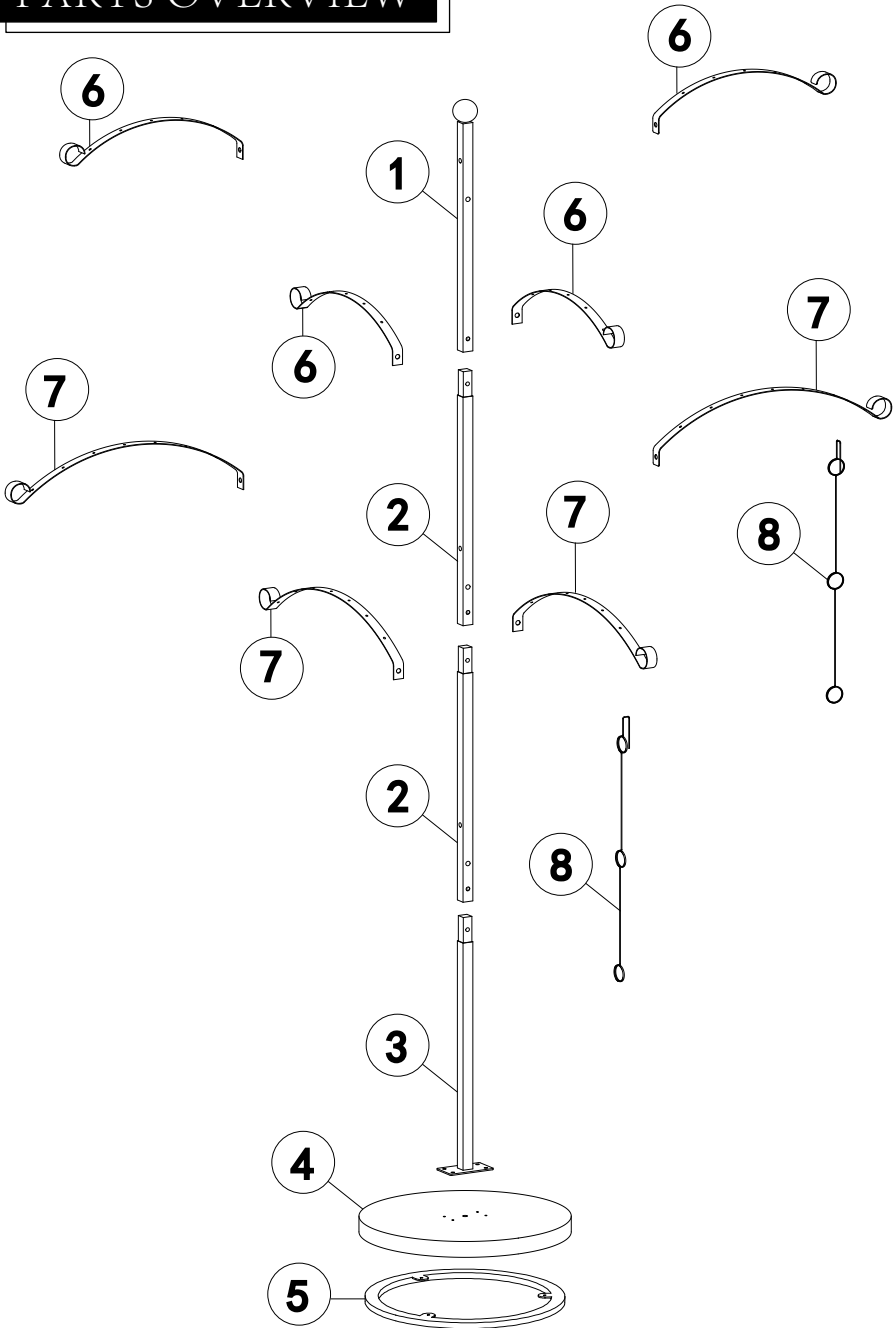

STEP 1

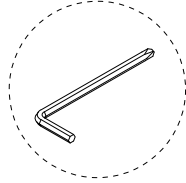
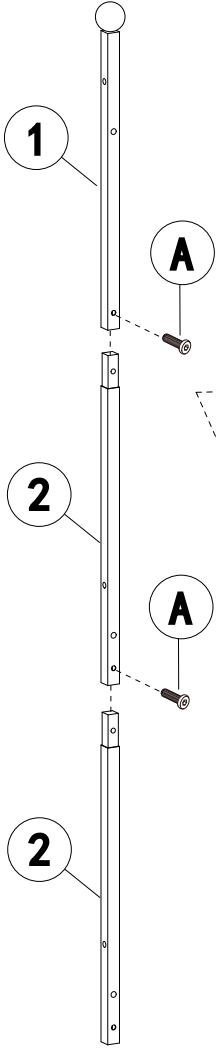
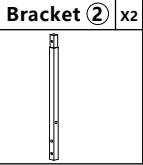
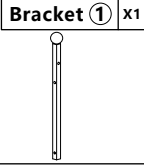
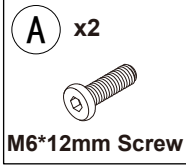

Use Allen Key

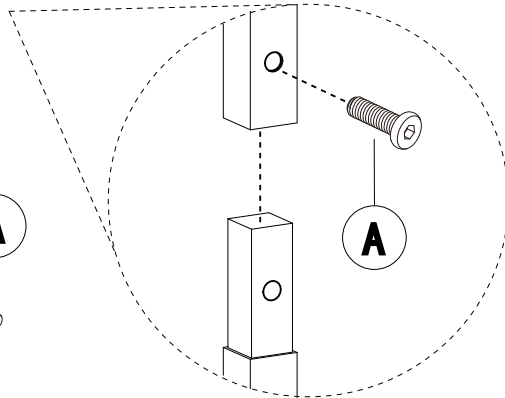

Find the parts and screws corresponding to the serial number, assemble them by aligning the holes according to the illustration, please tighten the screws.

STEP 2

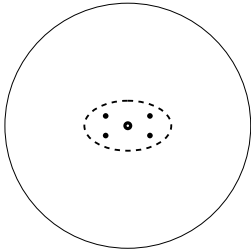
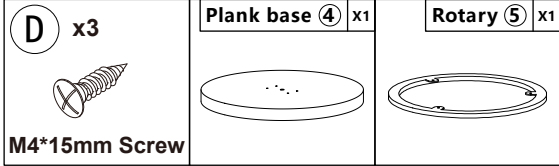

(Front)

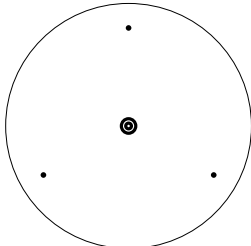

(Back)

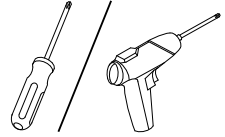

Use your own normal driver or electric driver

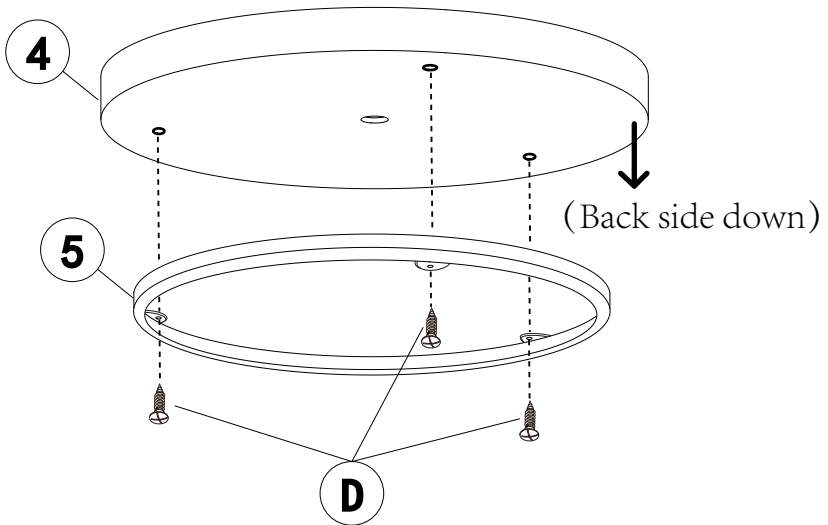

Distinguish between the front and back based on the holes in the planks.

Find the parts and screws corresponding to the serial number, assemble them by aligning the holes according to the illustration, please tighten the screws.

STEP 3

D x4



M4*15mm Screw

E x1

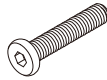

M6*40mm Screw

Bracket ③ x1

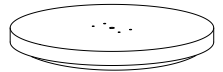

(STEP 2)

(1)

3

D

STEP 2

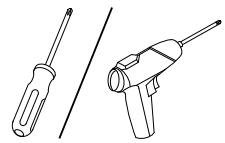
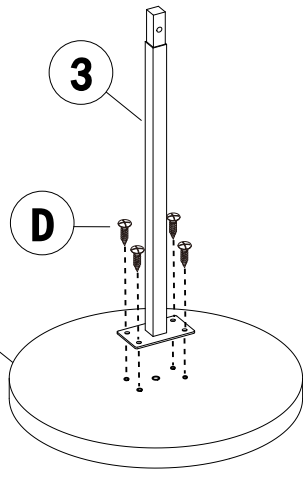

Use your own normal driver or electric driver

Find the parts and screws corresponding to the serial number, assemble them by aligning the holes according to the illustration, please tighten the screws.

(2)

3

STEP 2

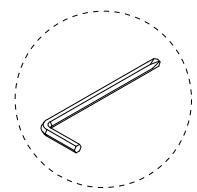
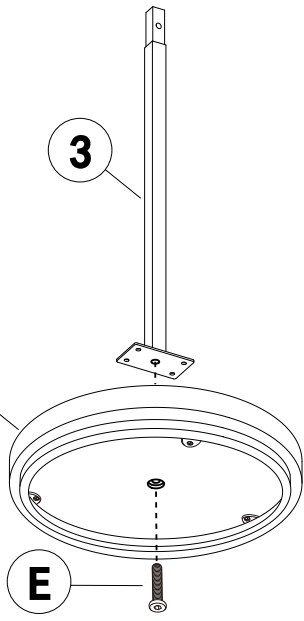

Use Allen Key

Find the parts and screws corresponding to the serial number, assemble them by aligning the holes according to the illustration, please tighten the screws.

STEP 4

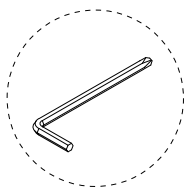
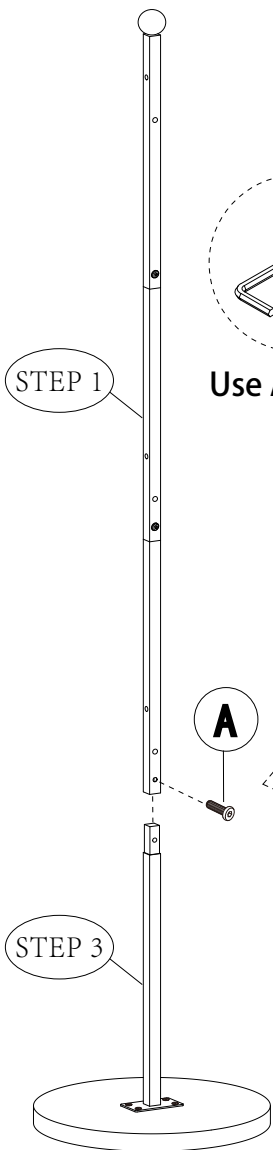
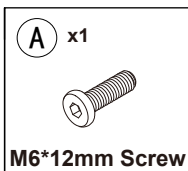

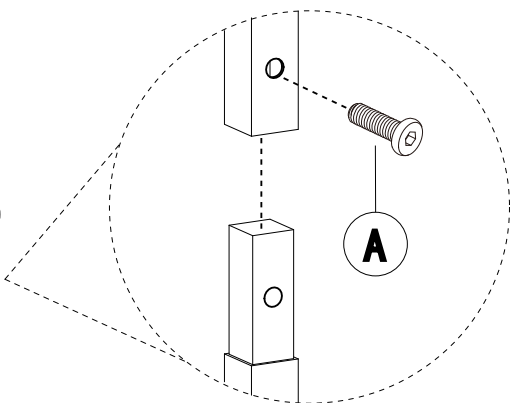
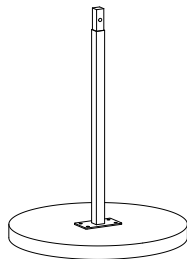

Use Allen Key



Find the parts and screws corresponding to the serial number, assemble them by aligning the holes according to the illustration, please tighten the screws.

STEP 5

B x2

M6*25mm Screw

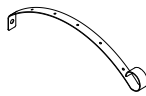
C x2

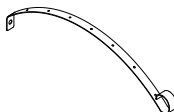
Nuts

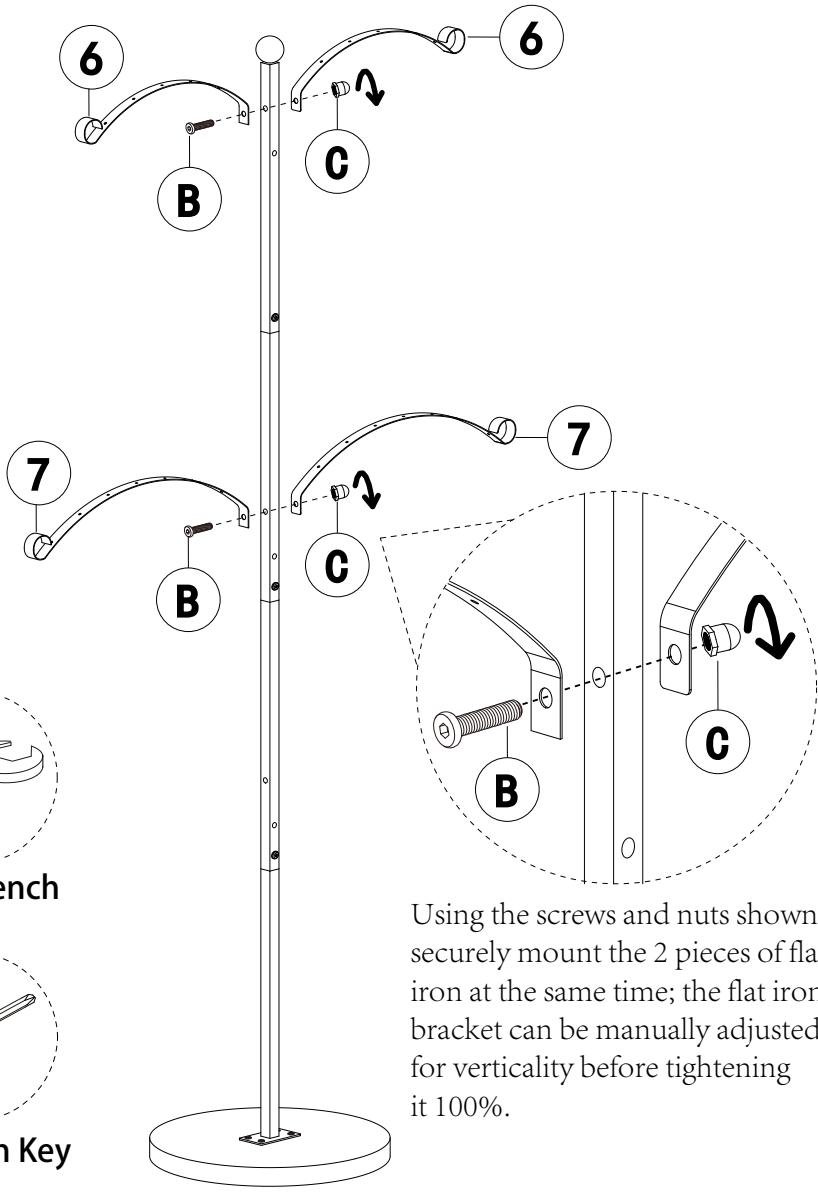
Small flat iron **6** x2

Large flat iron **7** x2



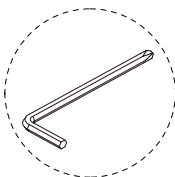

Use Wrench



Use Allen Key

Using the screws and nuts shown, securely mount the 2 pieces of flat iron at the same time; the flat iron bracket can be manually adjusted for verticality before tightening it 100%.

STEP 6

B x2

M6*25mm Screw

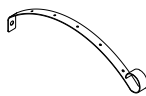
C x2

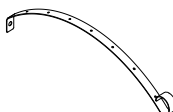
Nuts

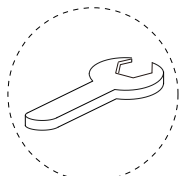
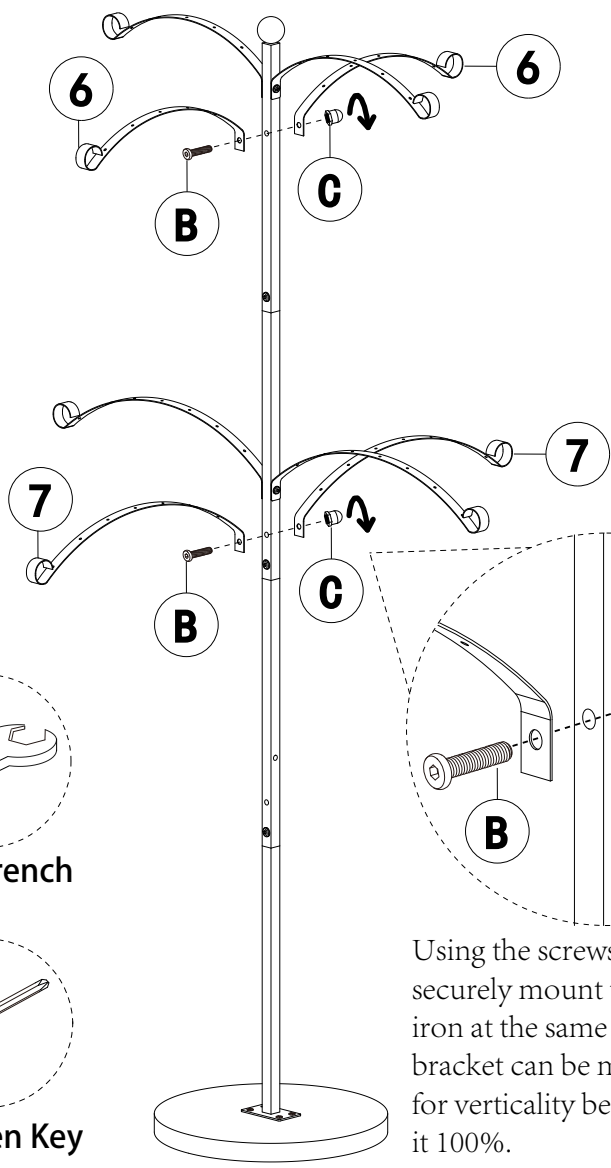
Small flat iron **6** x2

Large flat iron **7** x2

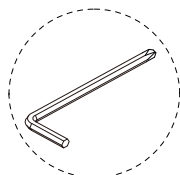

Use Wrench



Use Allen Key

Using the screws and nuts shown, securely mount the 2 pieces of flat iron at the same time; the flat iron bracket can be manually adjusted for verticality before tightening it 100%.

STEP 7

Photo clips ⑧ x30

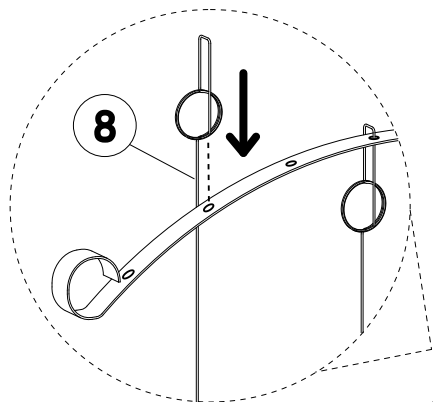

Use the photo clips to hold the photos you want to display, and then hang them in any holes of the flat iron bracket.

You can hang as many photo holders as you need. If the clips are slightly distorted, they can be adjusted manually.

