

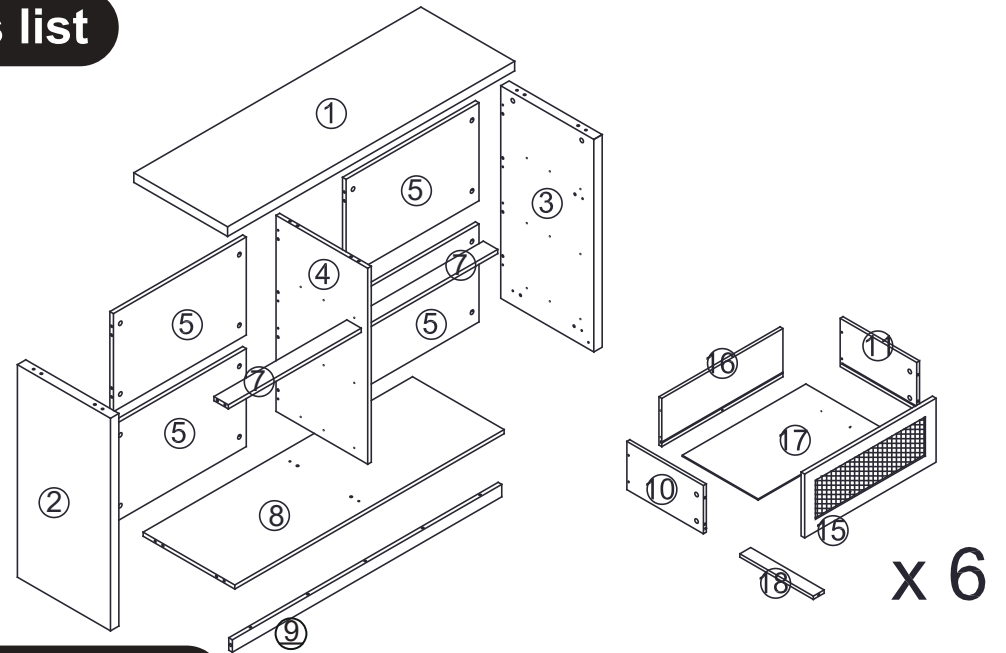

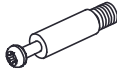









Parts list

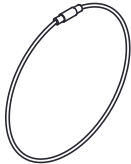

Hardware list

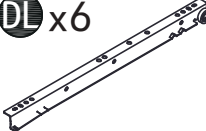
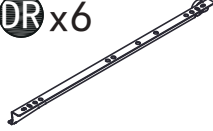
A x65 	B x65 	C x24 $\phi 8*30\text{MM}$ 	D x32 $\phi 4*35\text{MM}$ 	E x84 $\phi 3*12\text{MM}$ 
F x6 	G x65 	H x2    	I x5 $\phi 8*50\text{MM}$ 	
DL x6 	DR x6 	J x2  	CR x6 	
CL x6 				

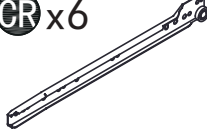
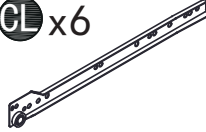
Step 1

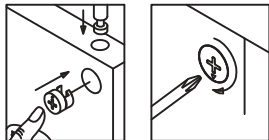
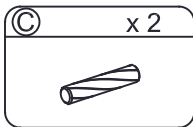
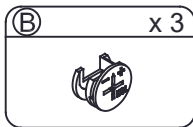
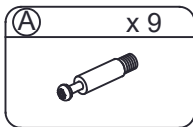
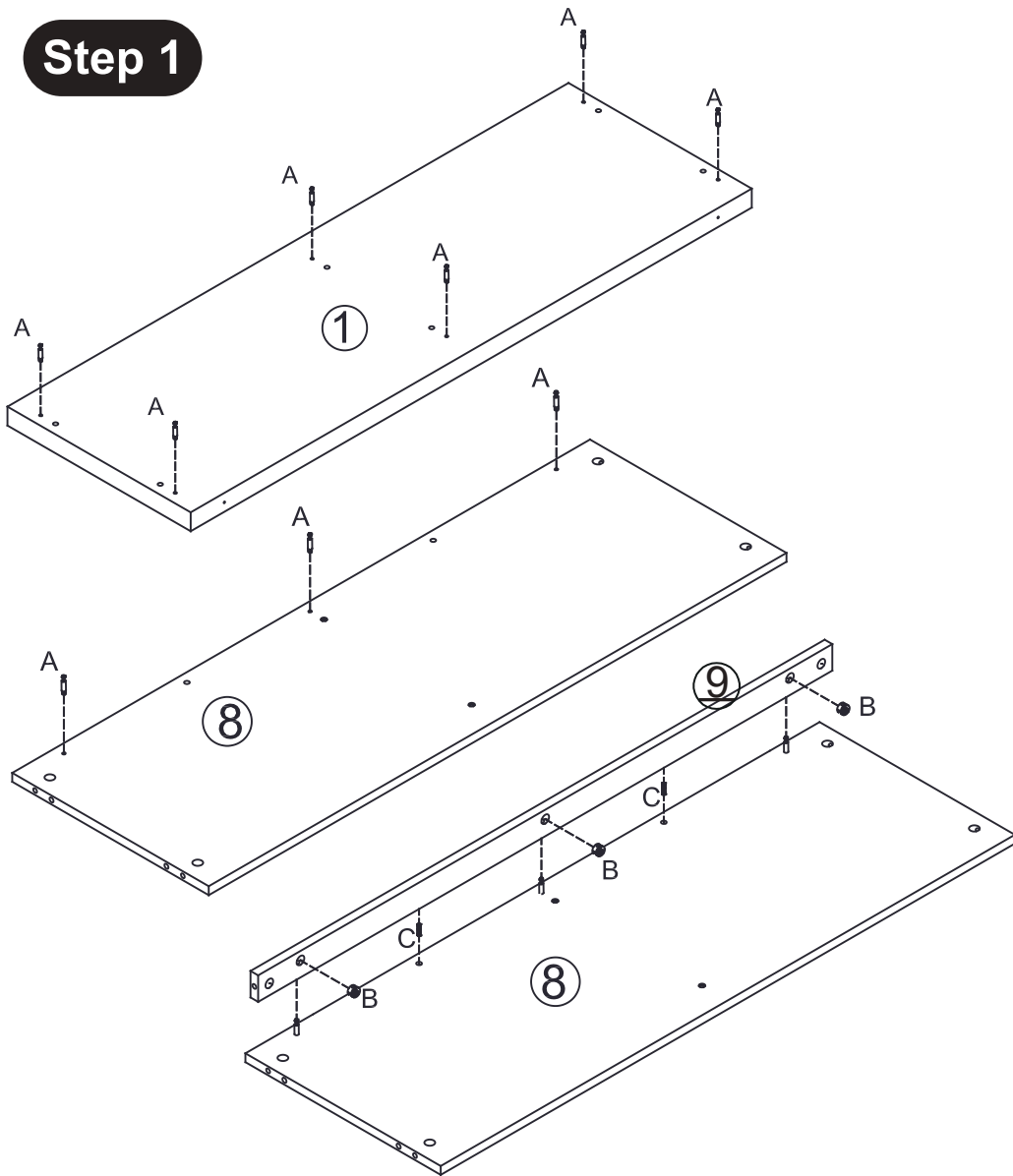

Step 2

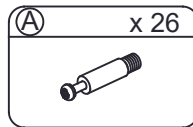
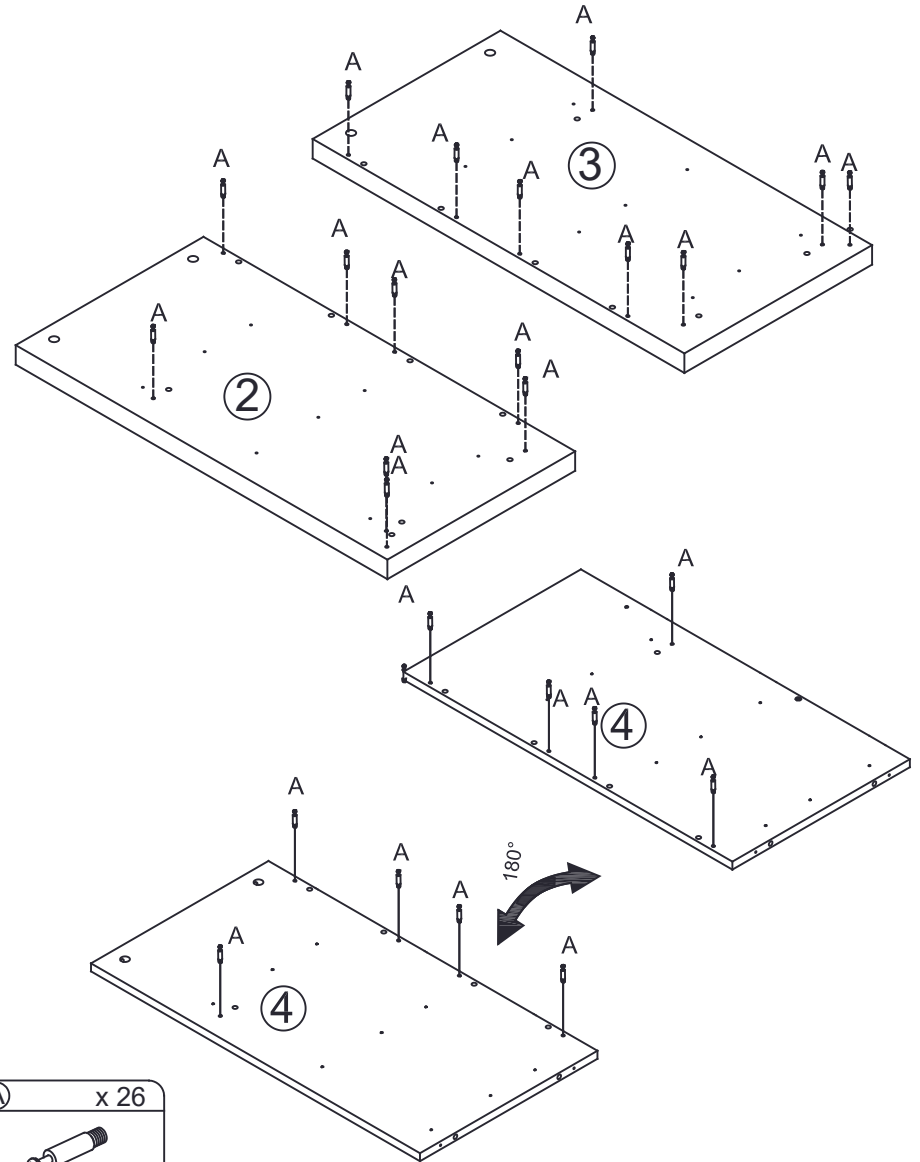

Step 3

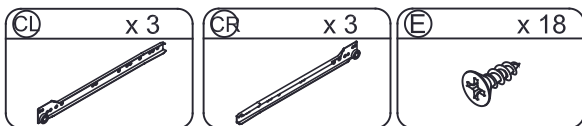
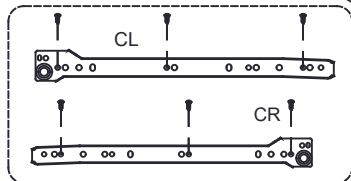
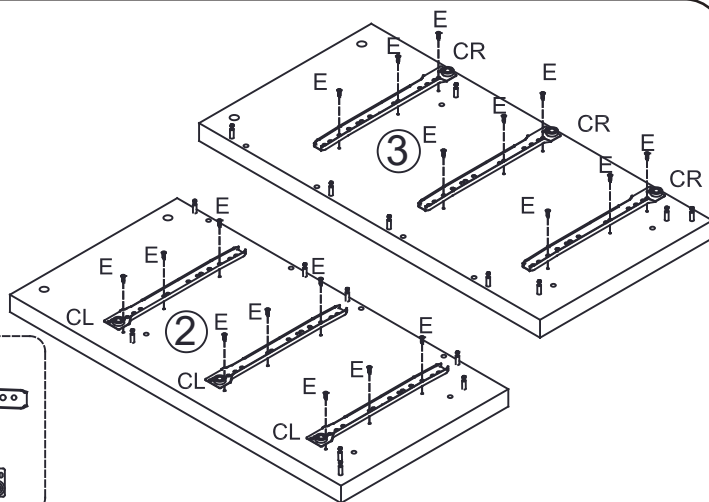

Step 5

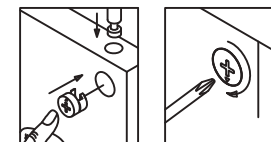
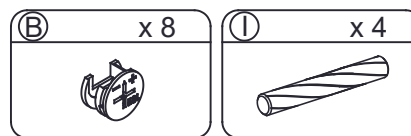
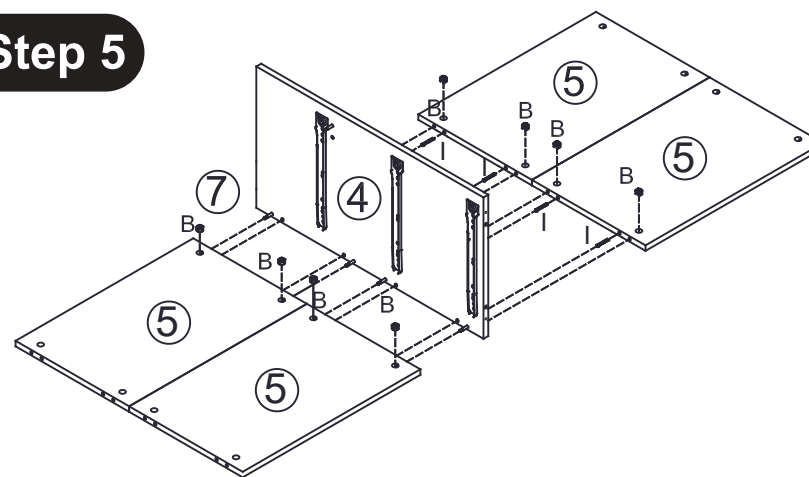

Step 4

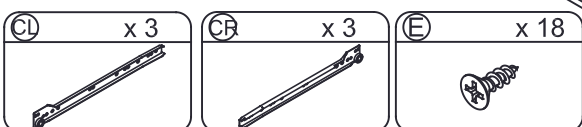
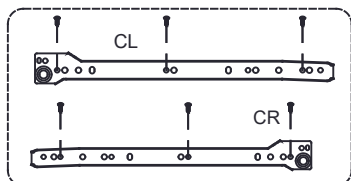
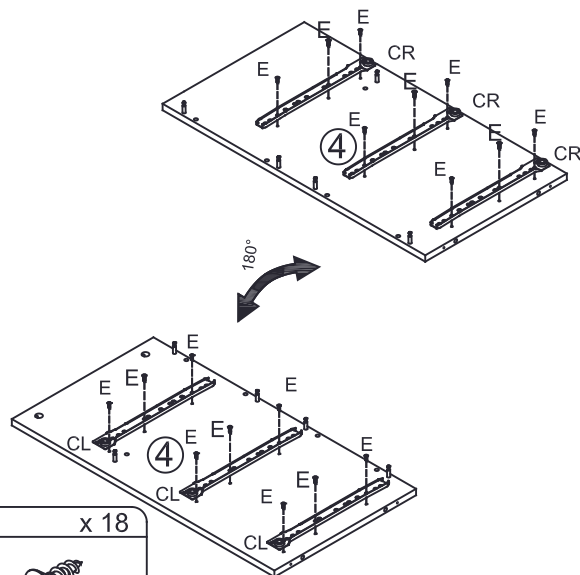

Step 6

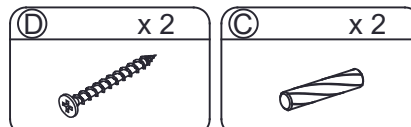
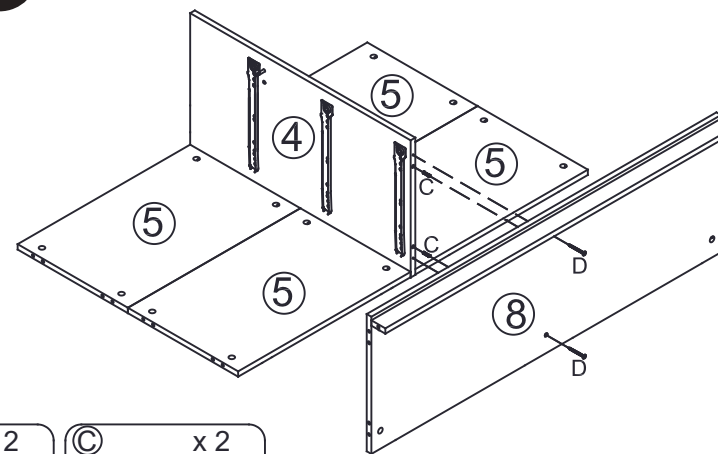

Step 7

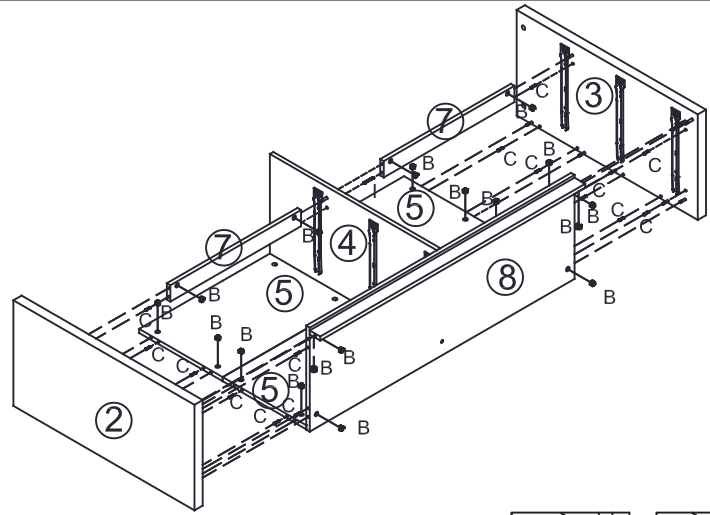

- (B) x 18
- (C) x 14
- (1) x 1

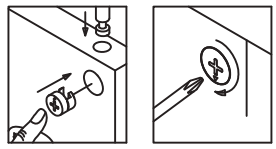

Step 9

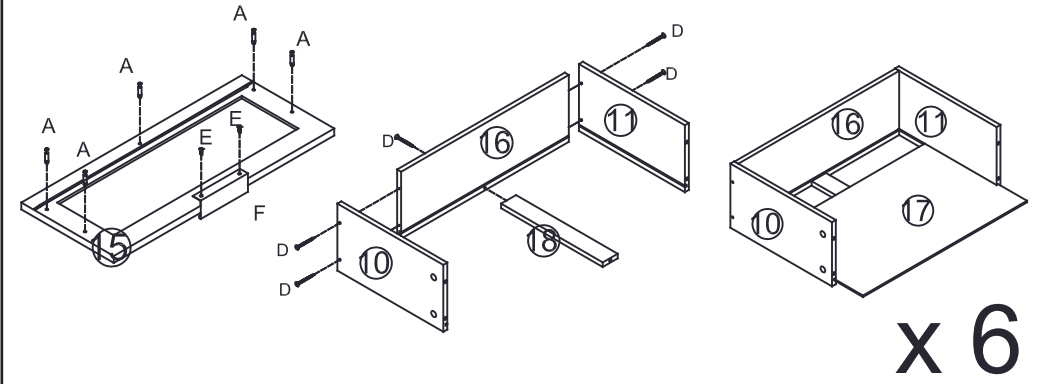

- (A) x 30
- (E) x 12
- (F) x 6
- (D) x 30

x 6

Step 8

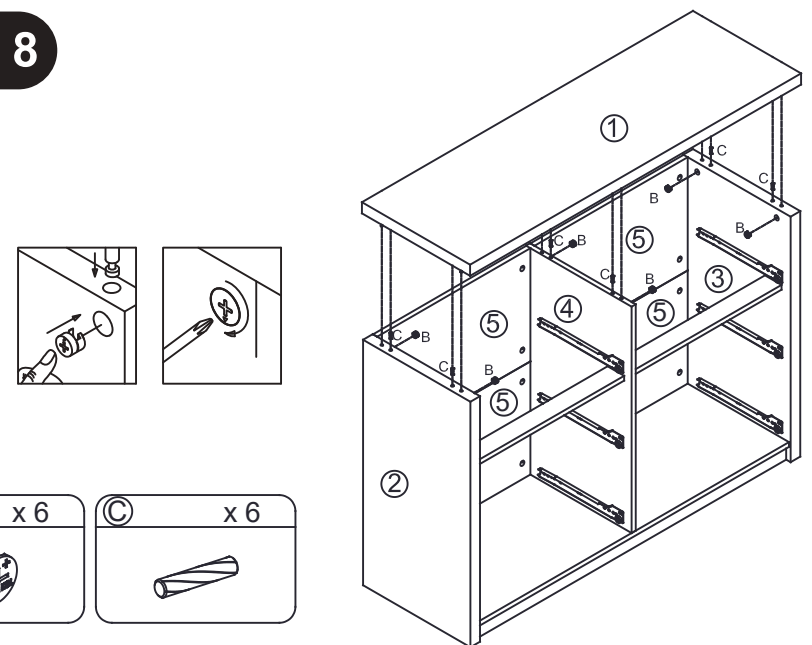

- (B) x 6
- (C) x 6

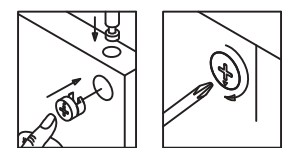

Step 10

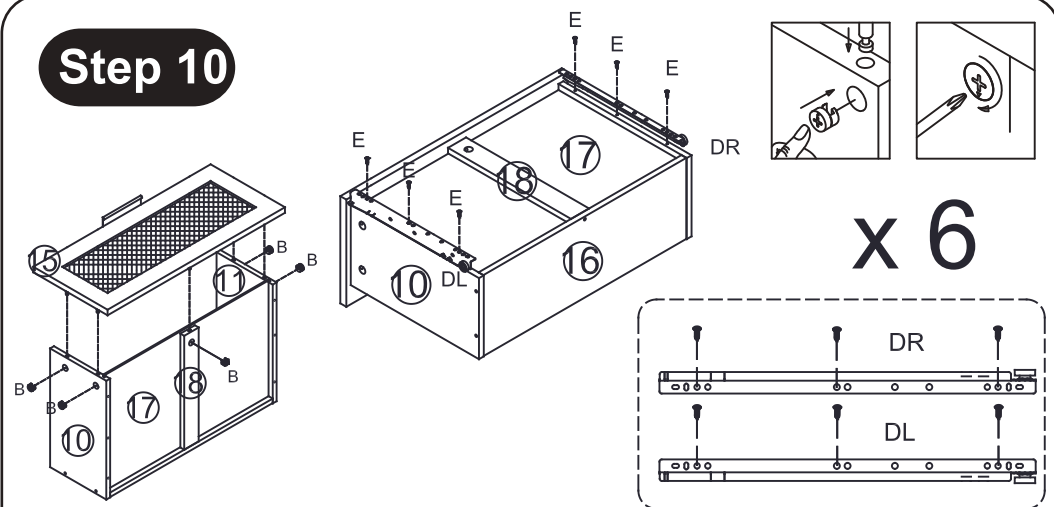

- (DR) x 6
- (DL) x 6
- (E) x 36
- (B) x 30

x 6

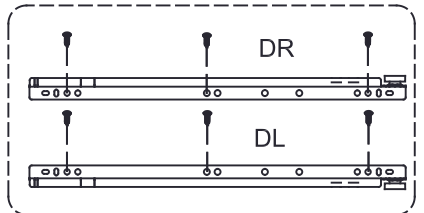

Step 11

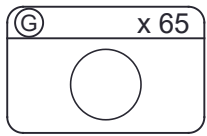
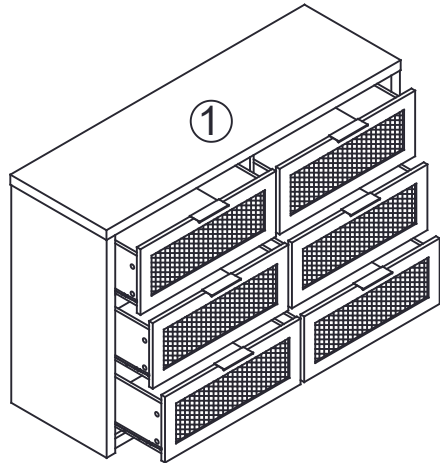
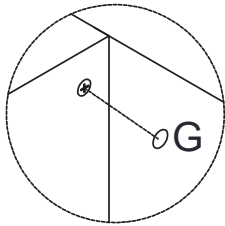

Step 13

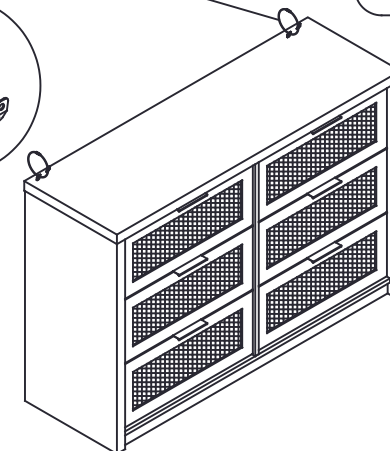
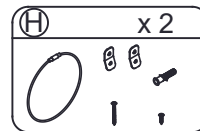
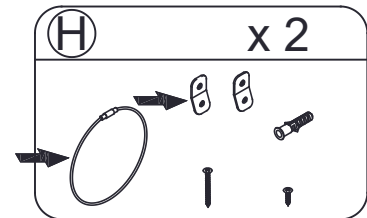
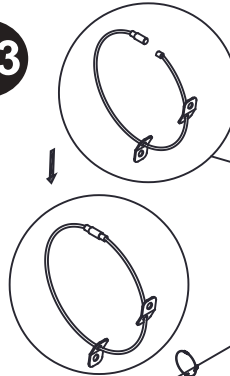

Step 12

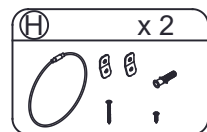
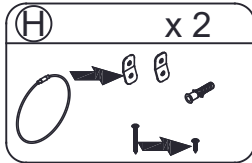
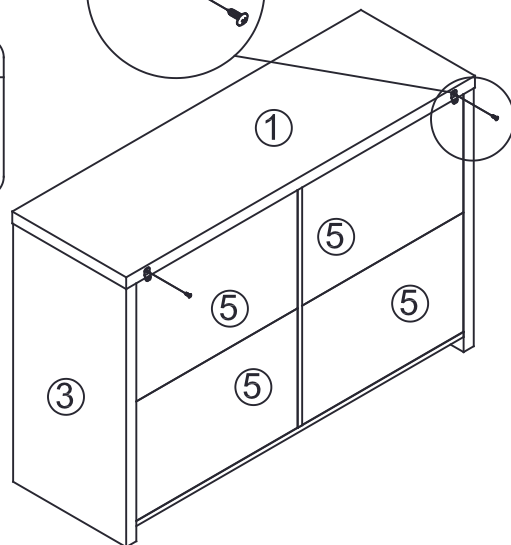
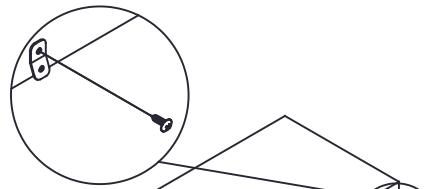

Step 14

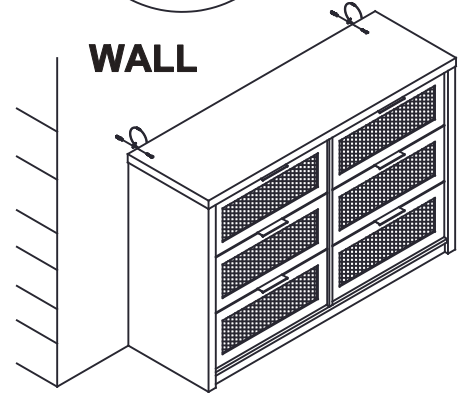
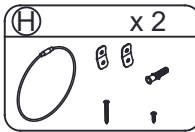
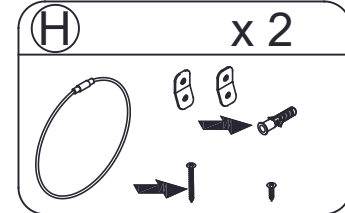
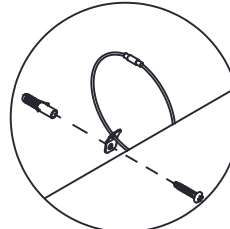
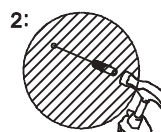
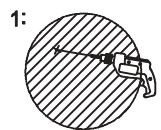



WARNING



Children have died from furniture tipover. To reduce the risk of furniture tipover:

- **ALWAYS** install Anti-tip device provided.
- **NEVER** put a TV on this product.
- **NEVER** allow children to stand, climb or hang on drawers, doors, or shelves.
- **NEVER** open more than one drawer at a time.
- **Place heaviest items in the lowest drawers.**



*This is a permanent label.
Do not remove!*

Adjusting the door

- Before adjusting the hinge, please check whether the cabinet is skewed.
- If the skew can not be repaired, please remove the anti-tipping device first, then adjust the cabinet to vertical position.
- Please adjust the hinge with the door open.
- Please operate it with more than 2 people, one person holds the door and the other one adjusts the screw.

Components Name

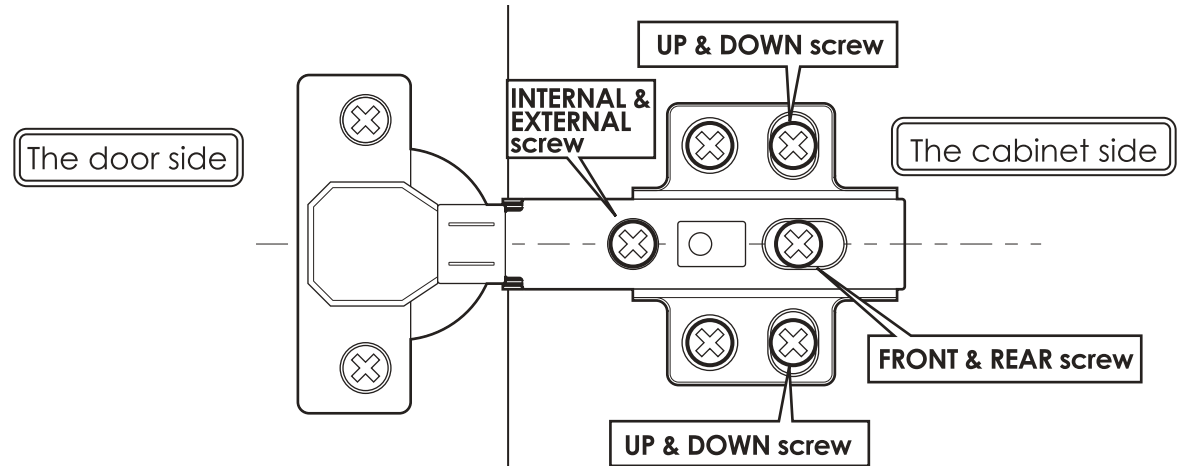

Obvious gaps between doors or Doors don't look closed

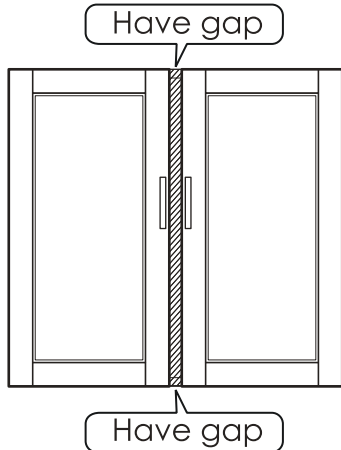

1 Turn "internal & external screw" to the right can make the door approach inside. Please adjust the doors little by little.

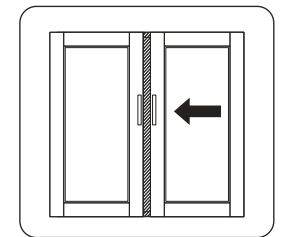
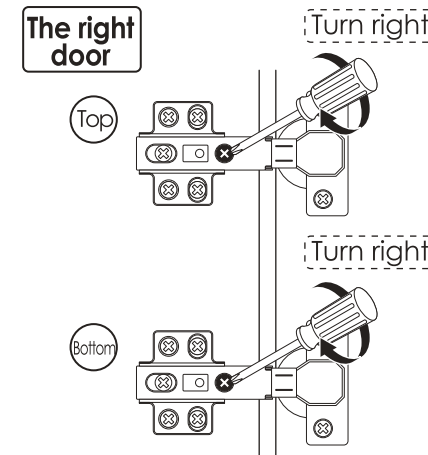
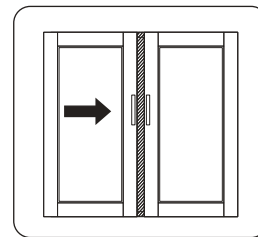
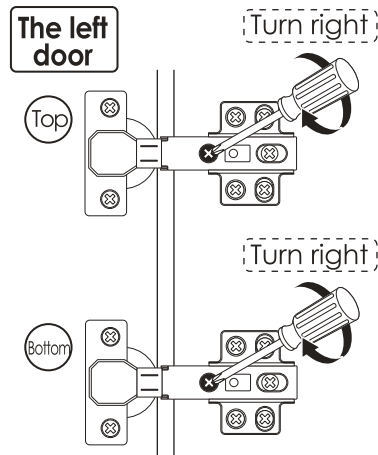

※ If the 2 doors are overlap, please turn the "internal & external screw" to the left.

When door is crooked



Please take the following steps to adjust first.

- 1 Rotate the "front and rear screws" to the left

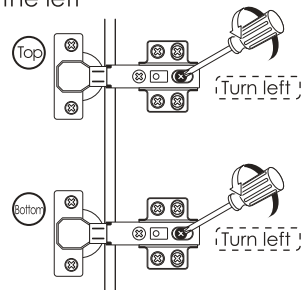

※ After adjusting the "front and rear screw", the door still does not change, please turn the "internal & external screw" to the right Slightly.

- 2 Push the door to the cabinet

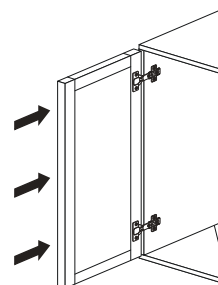

- 3 Rotate the "front and rear screws" to the right

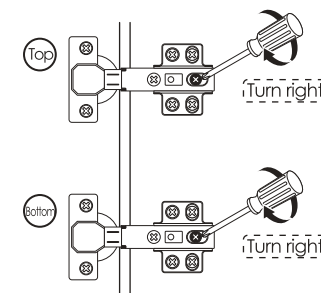

When door is leaning

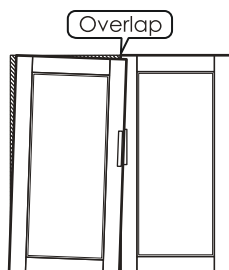

- 1 Turn "internal & external screw" to the left can make the top of the door tilted outward.

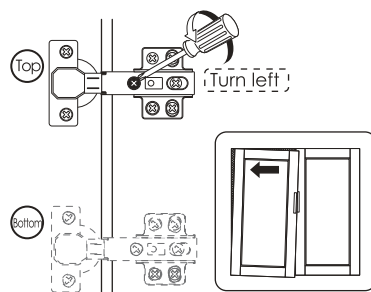

Protruding to the upside

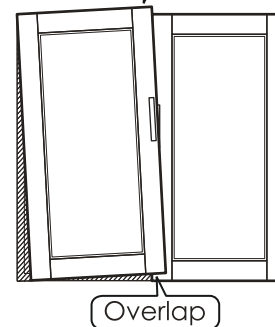

- 1 Turn "internal & external screw" to the left can make the bottom of the door tilted outward.

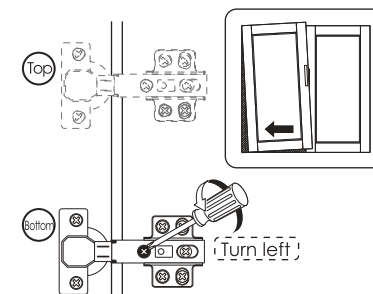

When the door is higher on top

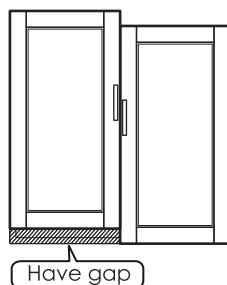

- 1 Turn "up & down screw" to the left

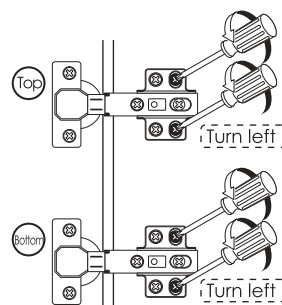

- 2 Lower the door's height so that 2 doors are of the same height.

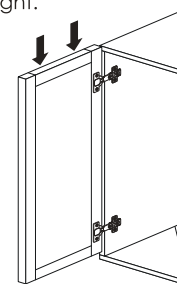

- 3 Turn "up & down screw" to the right

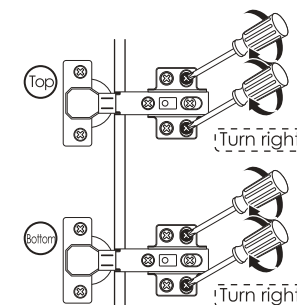

※ If the door is lower on bottom, please lift up the left door slightly on step 2

※ **Stay Scratch-Free: Safeguard Your Furniture by Assembling on Carpet.**

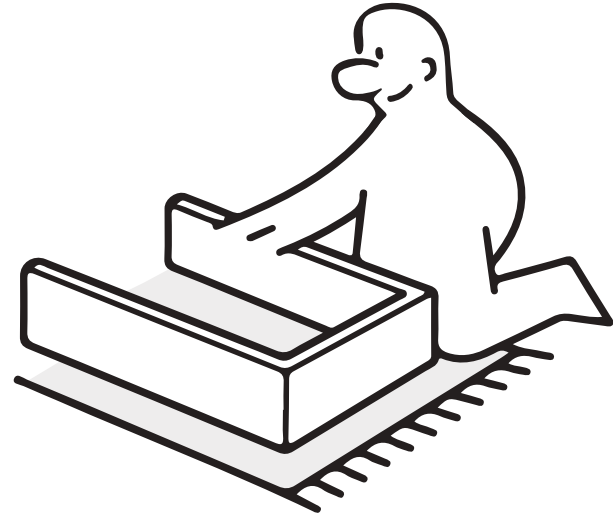
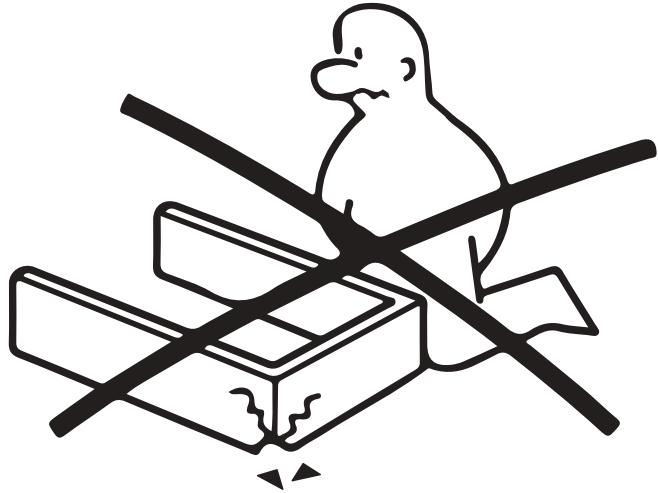

※ **Stuck in Assembly Limbo? Contact Our Support Team for Quick Solutions!**

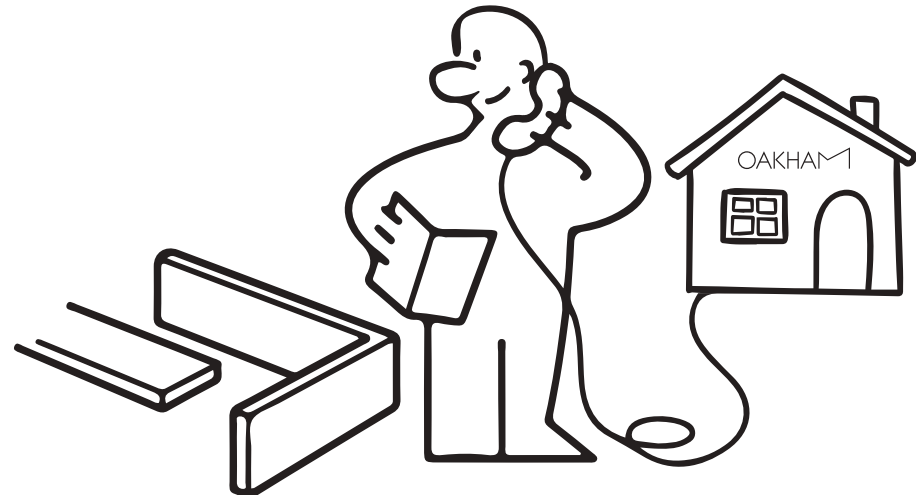
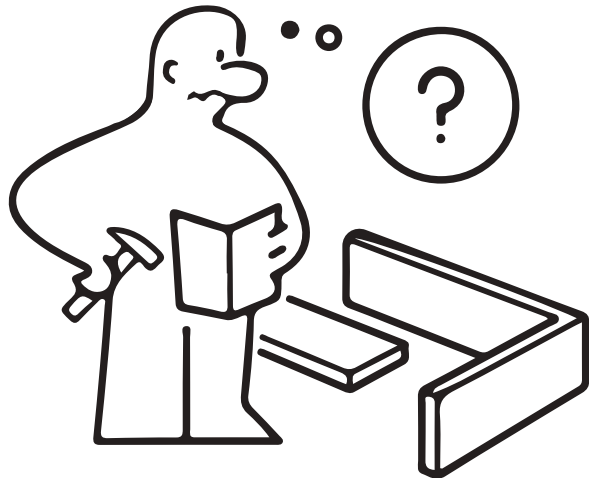

THANK YOU!

For purchasing from us

Despite our reinforced packaging, transit mishandling can sometimes occur. In the rare event that your product arrives damaged, we're here to assist you. **If your product is in perfect condition, you can disregard this message.**

If you discover any damage upon receipt of your package, please contact our after-sales mailbox immediately at our website.

Additionally, we kindly request your assistance in filing a claim against the shipping carrier for the mishandling of your package. Please help us by providing clear photos as follows:

- ☆ Complete Shipping Label: Take a clear image of the entire shipping label affixed to the package with visible and legible text and barcodes.
- ☆ Exterior Packaging Damage: Capture a comprehensive photo showing the damaged exterior of the shipping package.
- ☆ Interior Item Damage: Provide images focusing on the damaged areas of product

Your cooperation is invaluable, and we assure you that we're committed to resolving this issue promptly. Your satisfaction remains our top priority.

Thank you for your understanding and assistance.

Best regards,

Customer Support Team

Example:

