

# ASSEMBLY INSTRUCTIONS



VERSION-01

## Notice:

1. Please unbox the item from the side with an open label and put a carpet on the floor to avoid scratching it.
2. Follow the installation instructions carefully. before installation, please ensure that all accessories are present. For large items, we advise you to install them with 2 or more people for faster and safer installation.
3. Do not fully tighten the screws during initial assembly. Fully tighten the screws only once all pieces are correctly assembled.
4. Do not stand, climb, or swing on the product.
5. If you encounter any problems during installation, please contact our customer service.







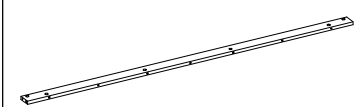
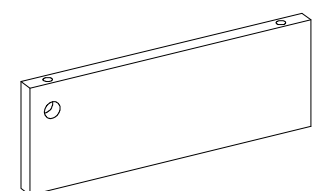
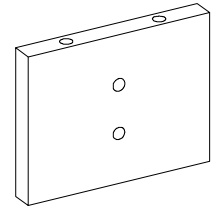
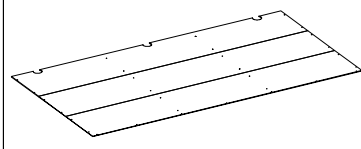
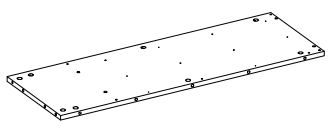
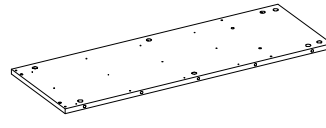
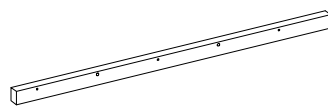
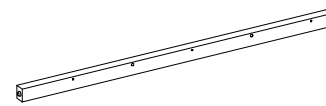
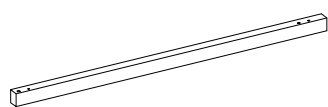
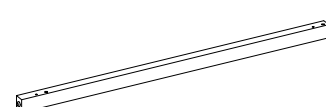

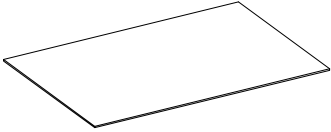
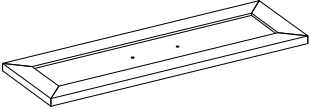
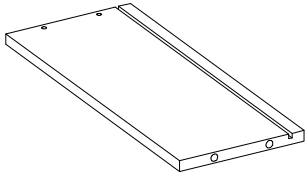
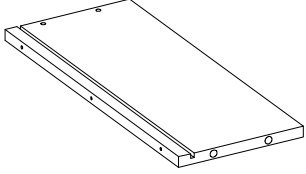
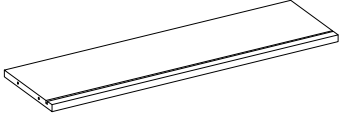
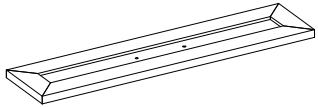
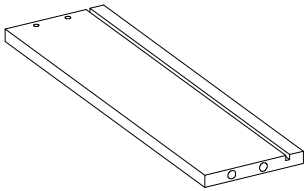
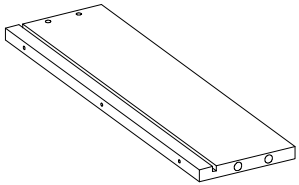
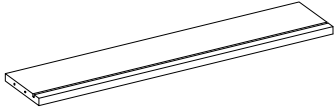

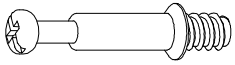

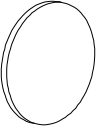
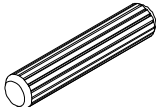
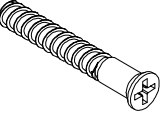
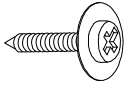

**SAFETY TIPS:**  
 Static charge may cause dust on foam - clean with a dry or damp cloth.  
 Small foam strands may be present - handle gently and dispose of properly.  
 Do not burn or incinerate. Check local recycling guidelines.

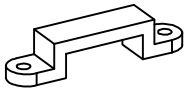
Item no.	Reference Image	Qty.	Item no.	Reference Image	Qty.
1		×1	2		×1
3		×2	4		×2
5		×1	6		×1

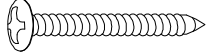
Item no.	Reference Image	Qty.	Item no.	Reference Image	Qty.
<b>7</b>		<b>×2</b>	<b>8</b>		<b>×2</b>
<b>9</b>		<b>×2</b>	<b>10</b>		<b>×1</b>
<b>11</b>		<b>×1</b>	<b>12</b>		<b>×1</b>
<b>13</b>		<b>×1</b>	<b>14</b>		<b>×1</b>
<b>15</b>		<b>×1</b>	<b>16</b>		<b>×1</b>

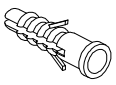
Item no.	Reference Image	Qty.	Item no.	Reference Image	Qty.
<b>17</b>		<b>×12</b>	<b>18</b>		<b>×9</b>
<b>19</b>		<b>×9</b>	<b>20</b>		<b>×9</b>
<b>21</b>		<b>×9</b>	<b>22</b>		<b>×3</b>
<b>23</b>		<b>×3</b>	<b>24</b>		<b>×3</b>
<b>25</b>		<b>×3</b>			

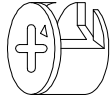
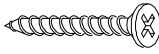
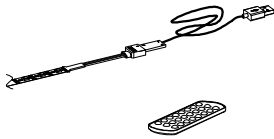
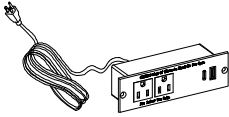
Item no.	Reference Image	Qty.	Item no.	Reference Image	Qty.
<b>A</b>		× 98 <sub>+2</sub>	<b>B</b>	 φ15x11mm	× 50 <sub>+2</sub>
<b>C</b>	 φ30mm	× 98 <sub>+2</sub>	<b>D</b>	 φ8x30mm	× 50 <sub>+2</sub>
<b>E</b>	 φ5*50mm	× 10 <sub>+2</sub>	<b>F</b>	 φ3.5x12mm	× 31 <sub>+2</sub>
<b>G</b>		× 12	<b>H</b>	 φ4x8mm	× 24 <sub>+2</sub>
<b>I</b>	 φ3x8mm	× 20 <sub>+2</sub>	<b>J</b>		× 9 <sub>+2</sub>
<b>K</b>		× 2	<b>L</b>	 φ4x35mm	× 2
<b>M</b>	 φ4x12mm	× 2	<b>N</b>		× 2

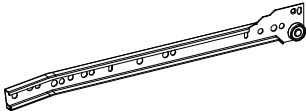
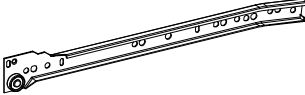
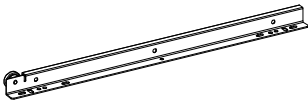
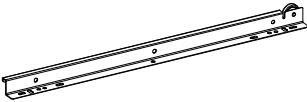
Item no.	Reference Image	Qty.	Item no.	Reference Image	Qty.
<b>O</b>	 ø15x9.5mm	× 48+2	<b>P</b>	 ø4x38mm	× 48+2
<b>Q</b>		× 1	<b>R</b>		× 1
<b>S</b>	 ø3.5x12mm	× 144+2			
<b>CR</b>		× 12	<b>CL</b>		× 12
<b>DR</b>		× 12	<b>DL</b>		× 12



Tips: The number after "+" represents the spare hardware.

# Explosion Diagram

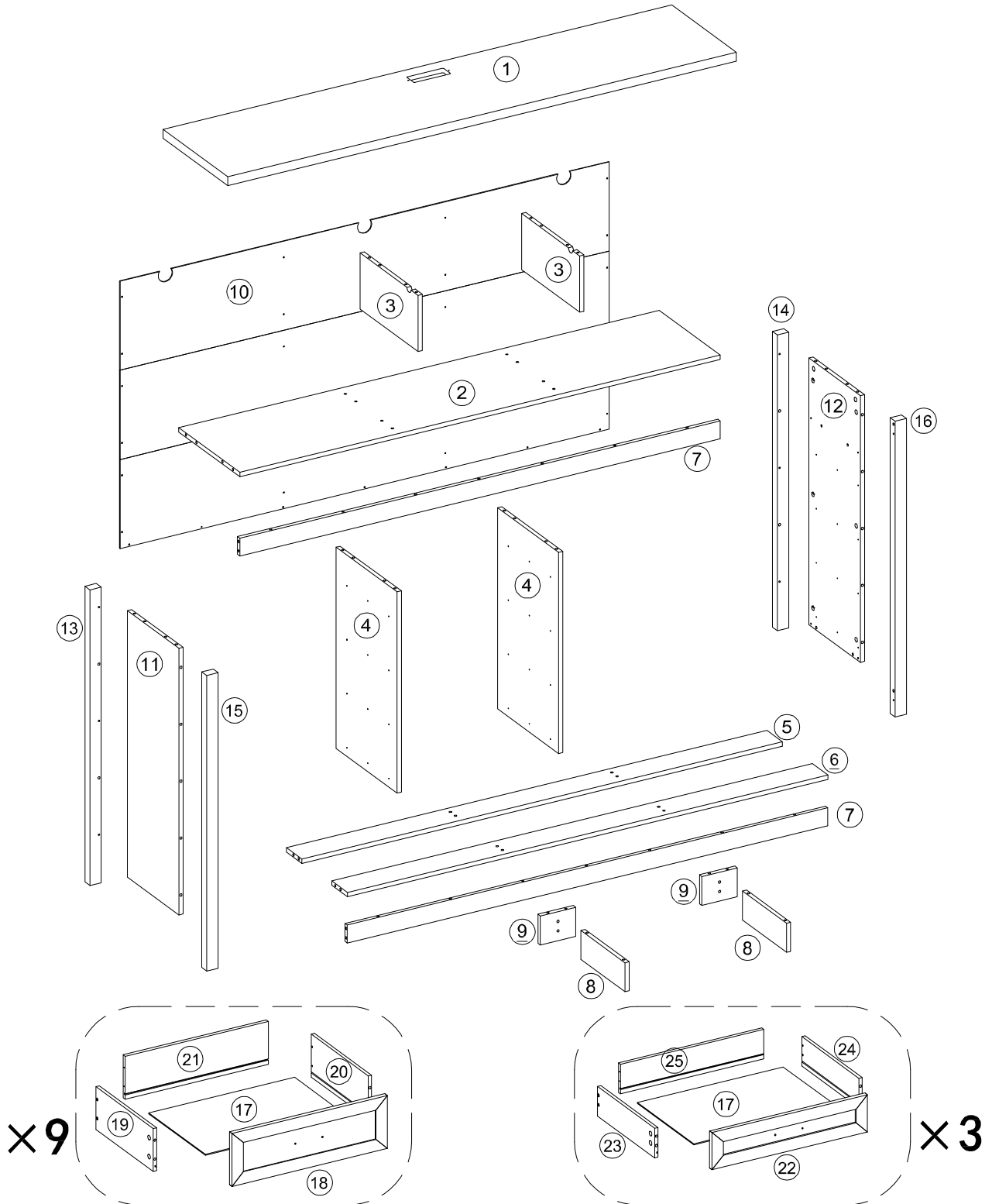

Explosion Diagram

PACKED "A"

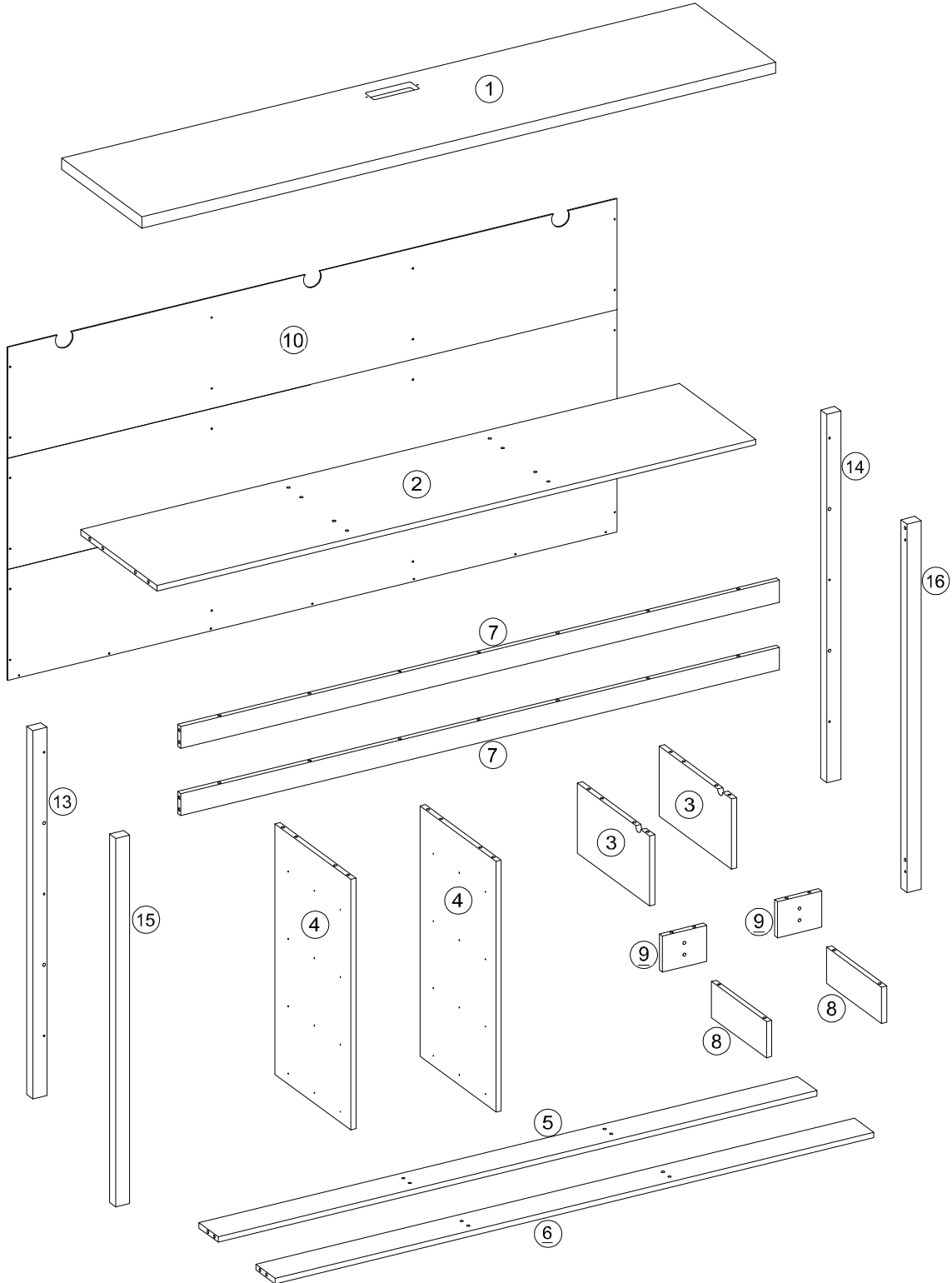

Explosion Diagram

PACKED "B"

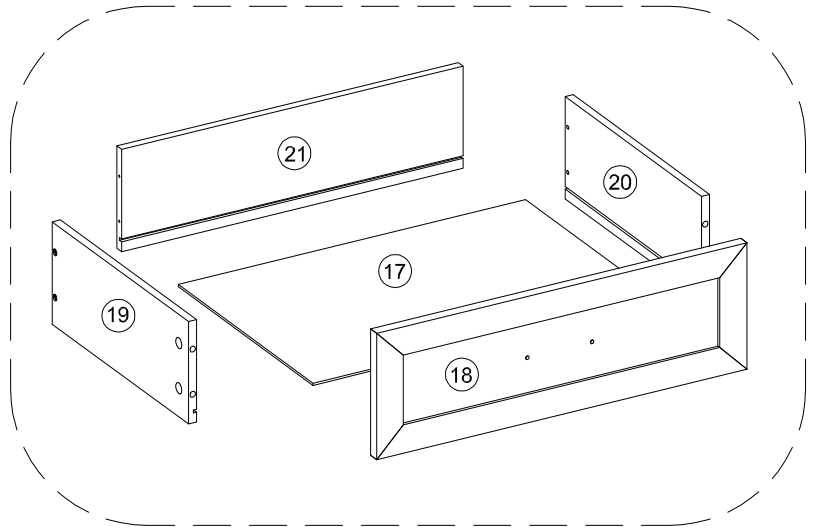
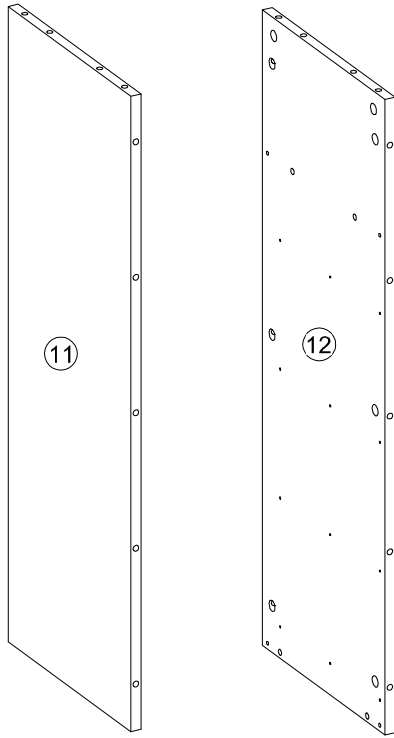

**×9**

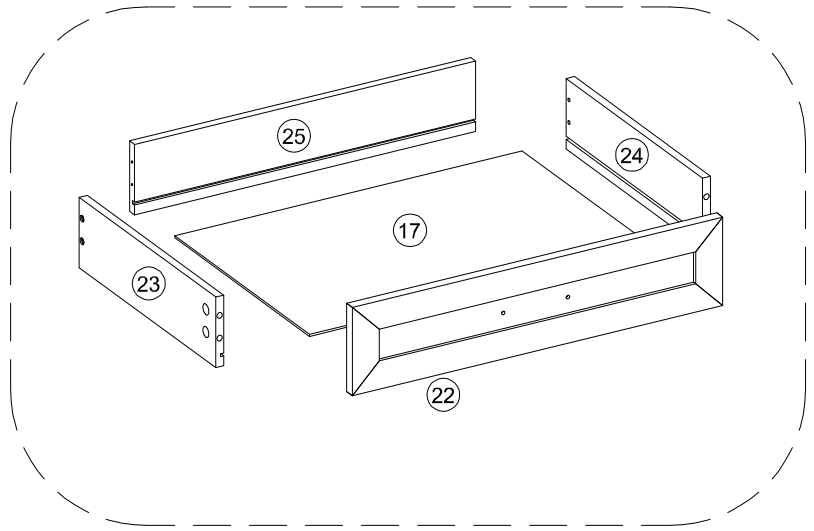

**×3**

# 1



Dx4

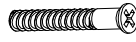

Ex4

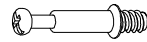

Ax4

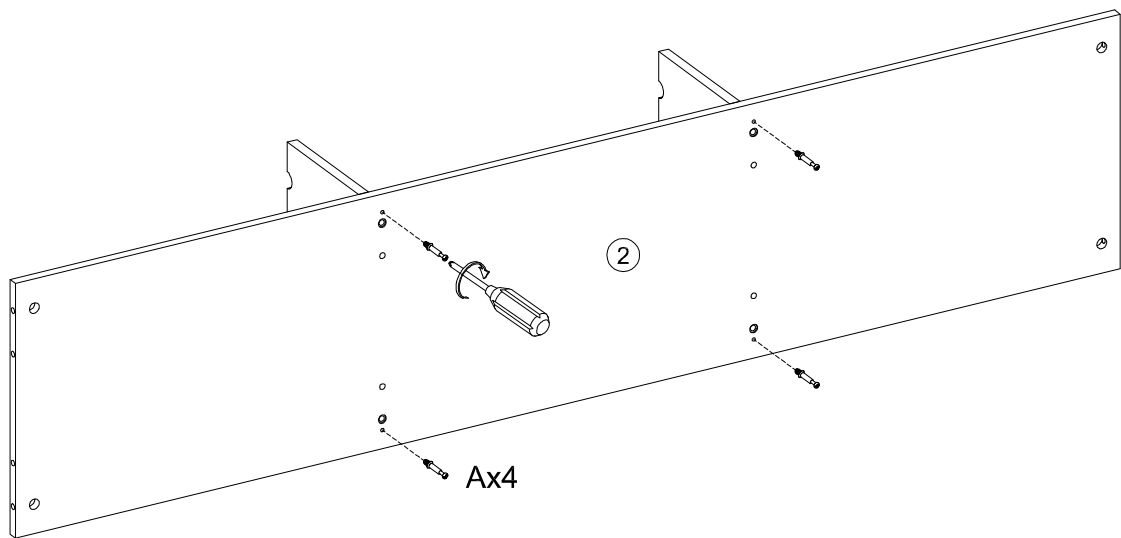
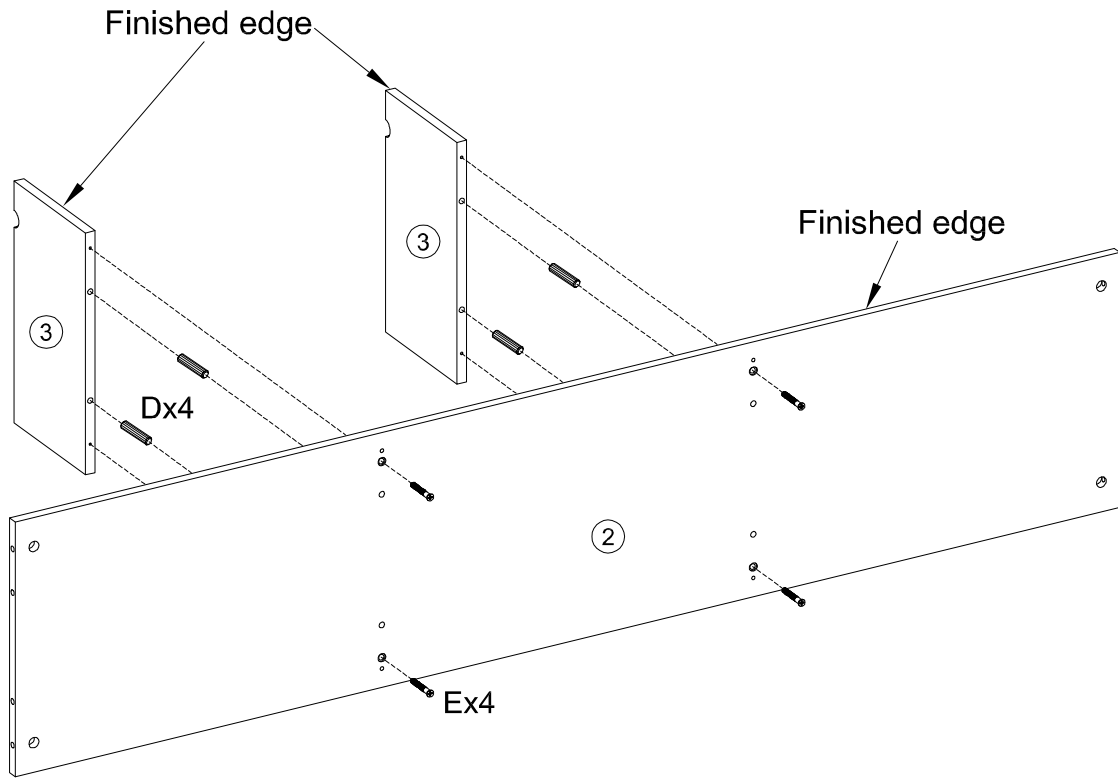

2



CLx8

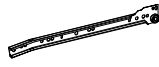

CRx8



Sx48

×2

CL

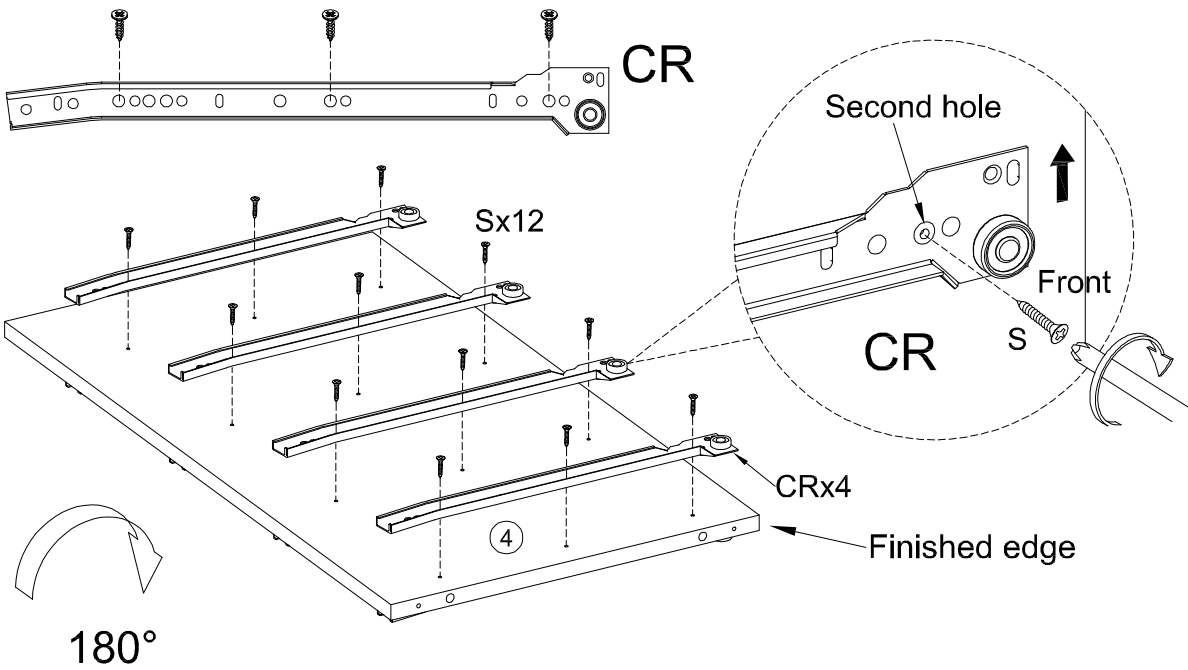
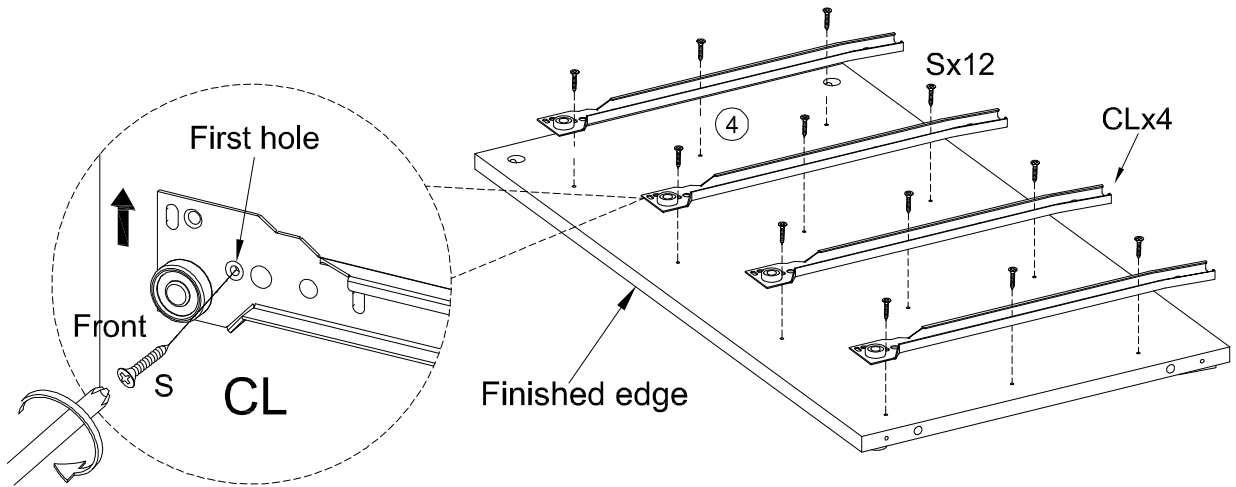
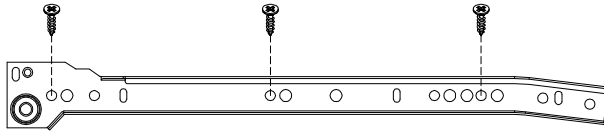

# 3



Dx4



Bx4

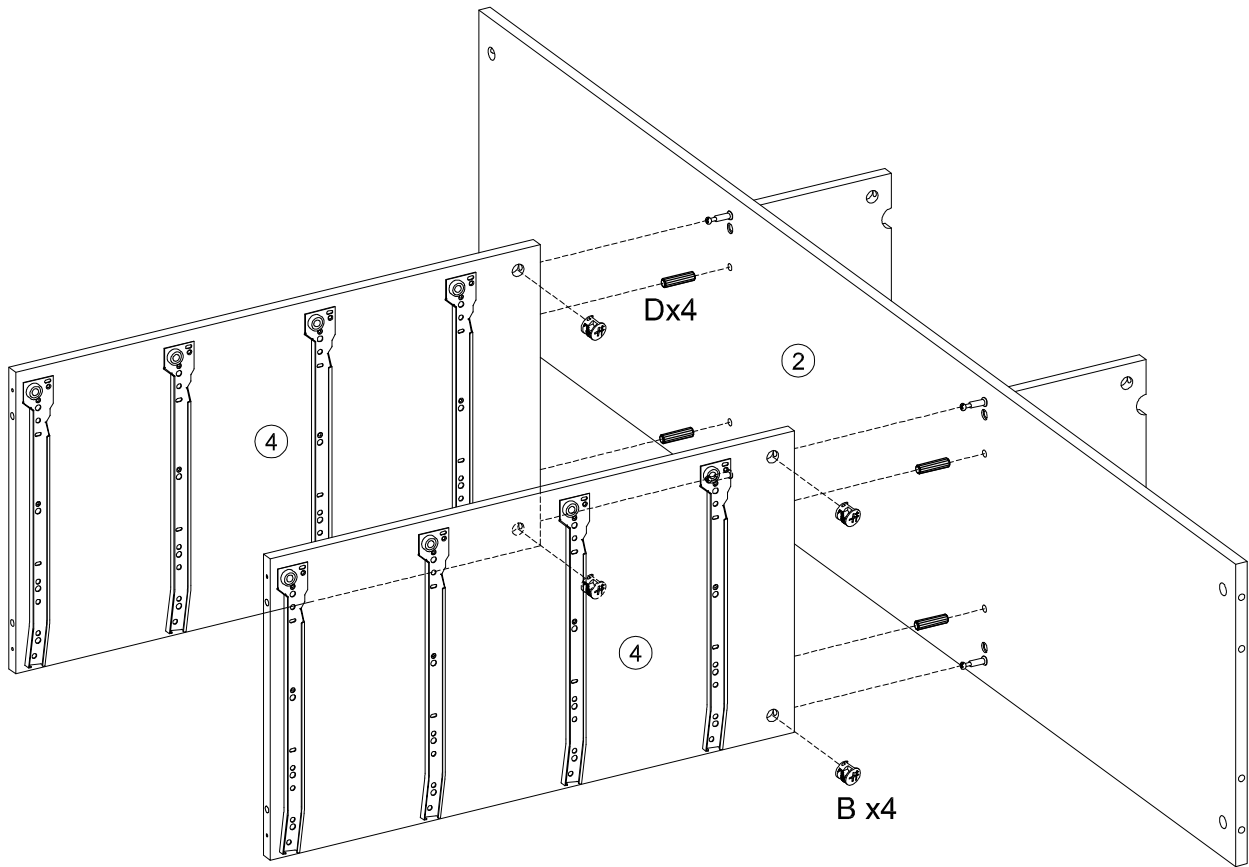
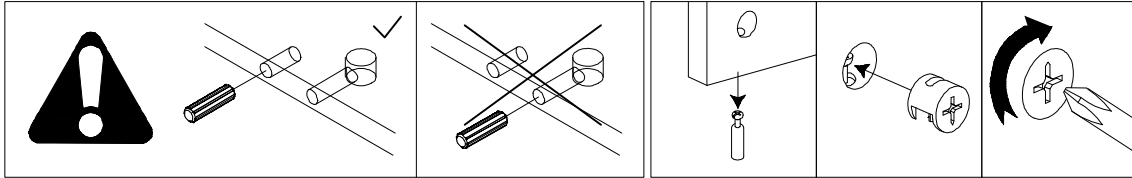

# 4

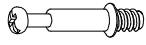

Ax4

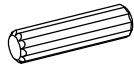

Dx3



Bx4

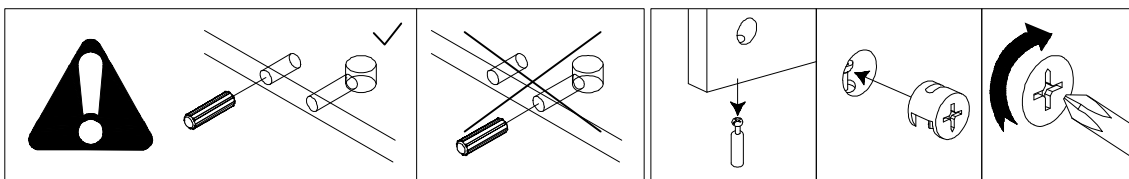
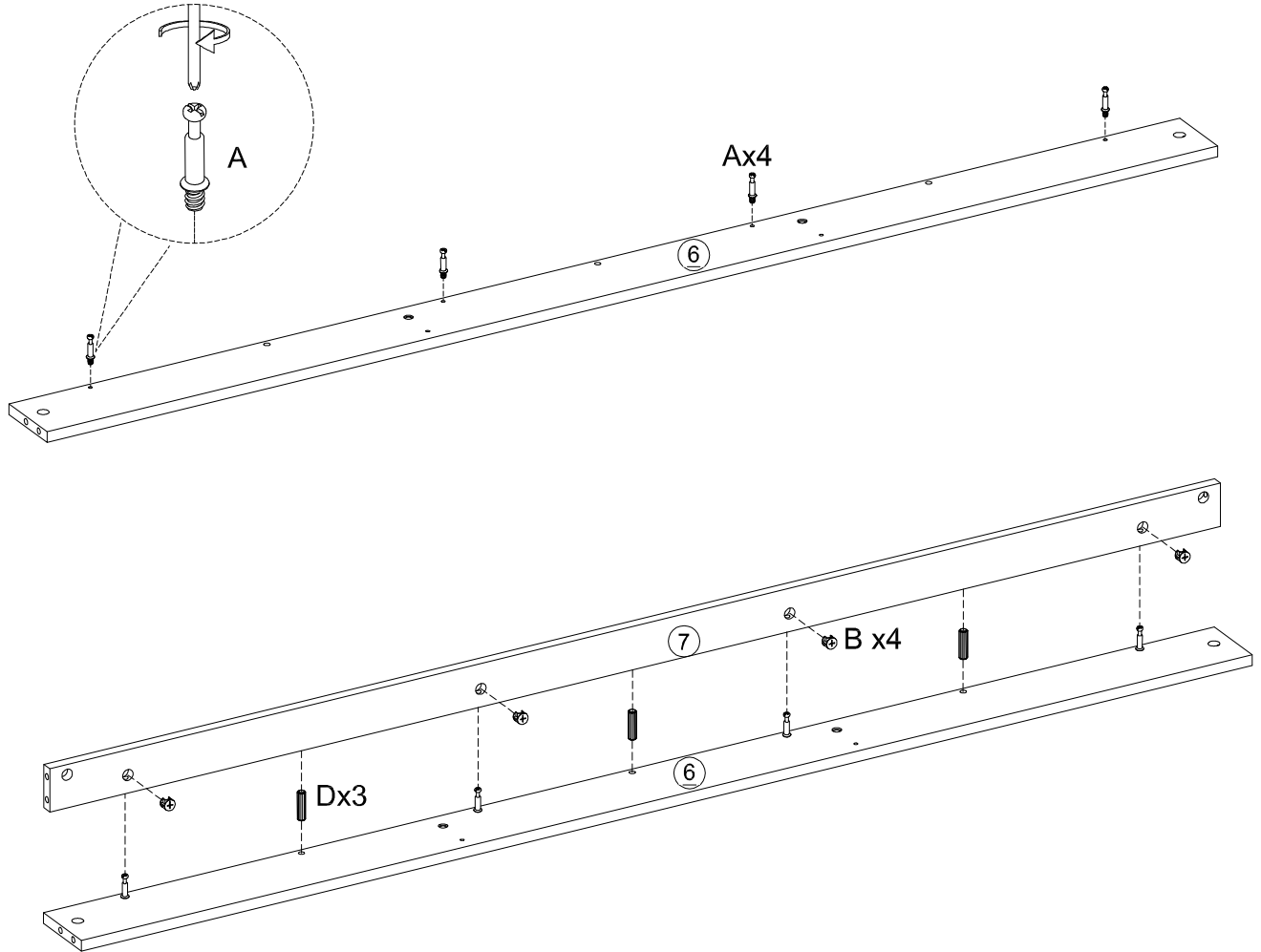

5



Dx4

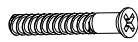

Ex4

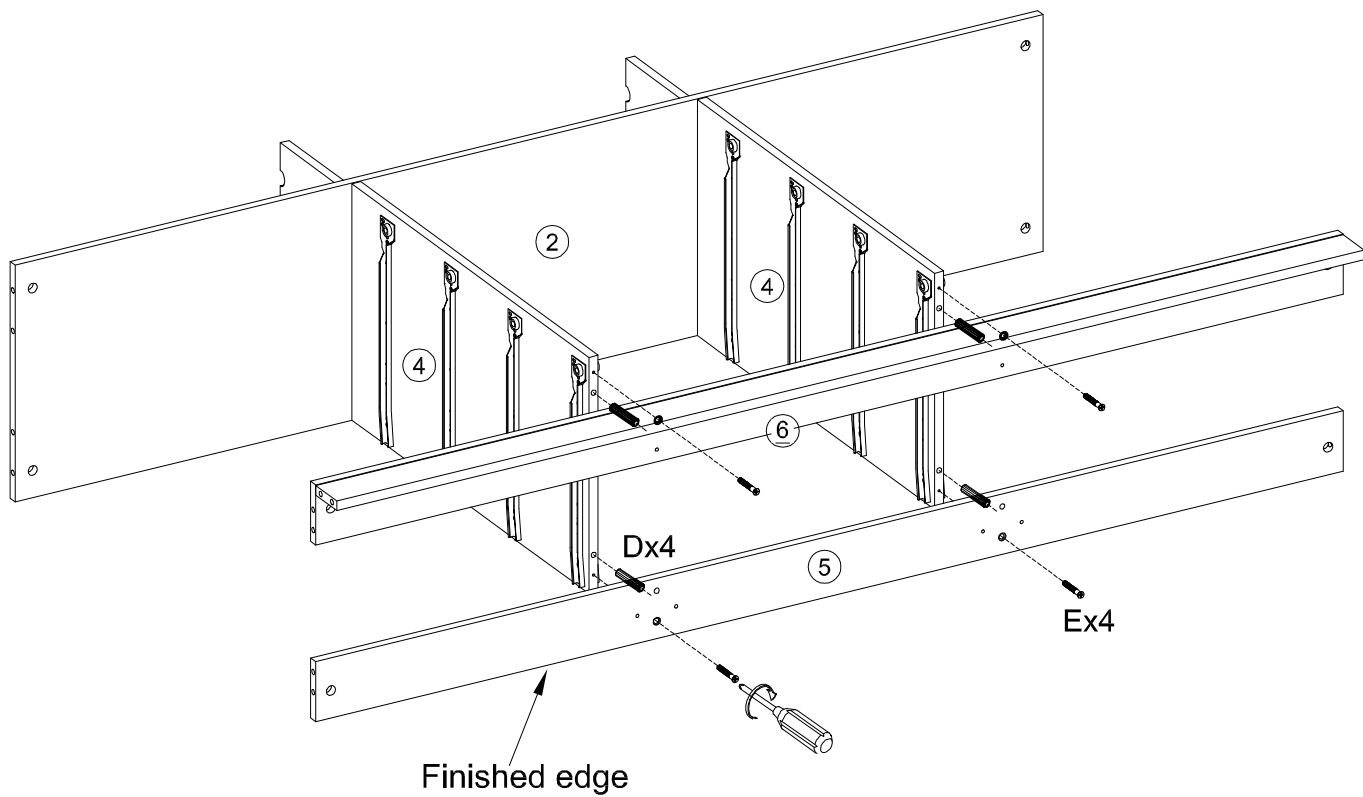

# 6

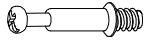

Ax16

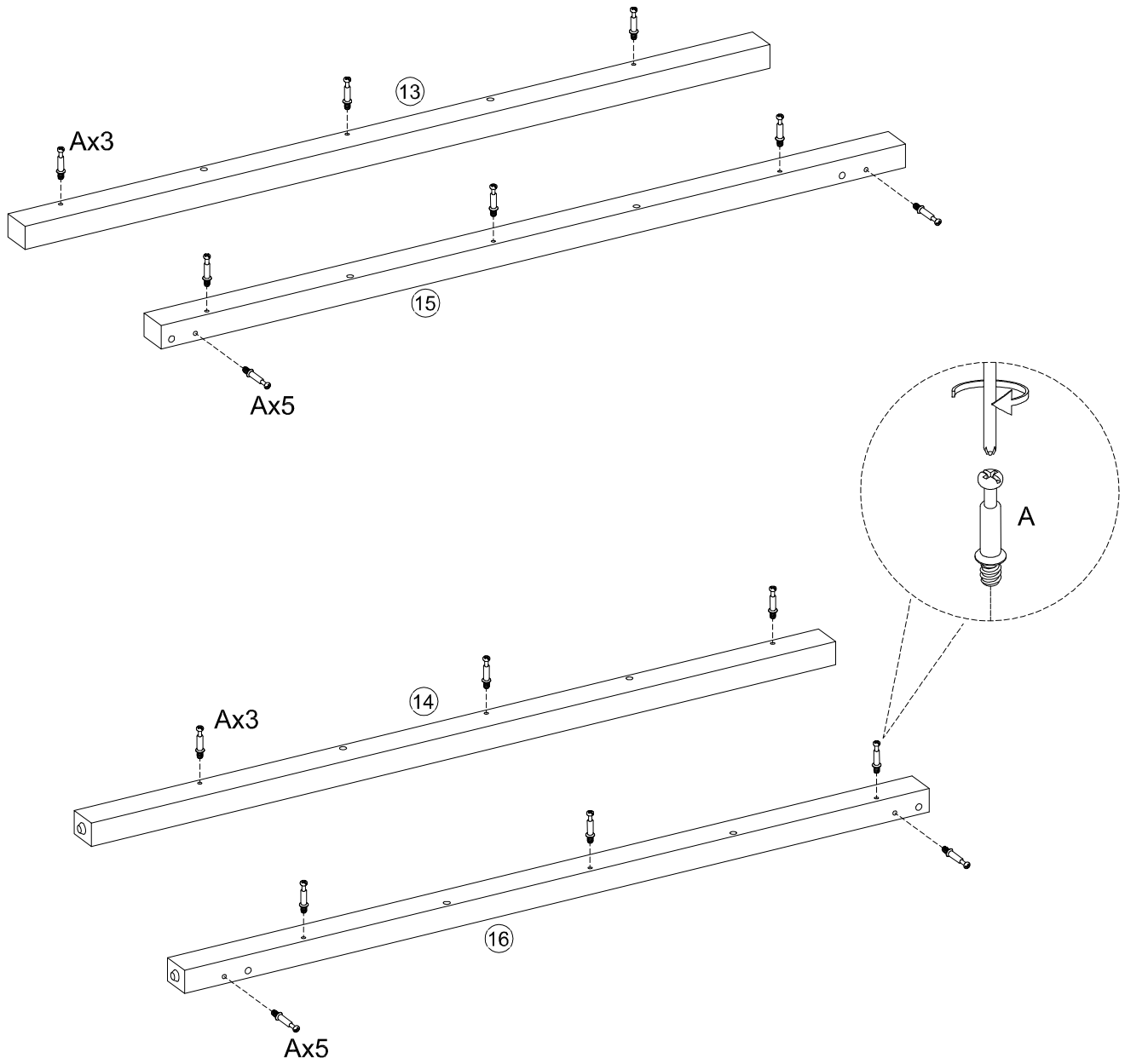

7

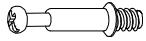

Ax8

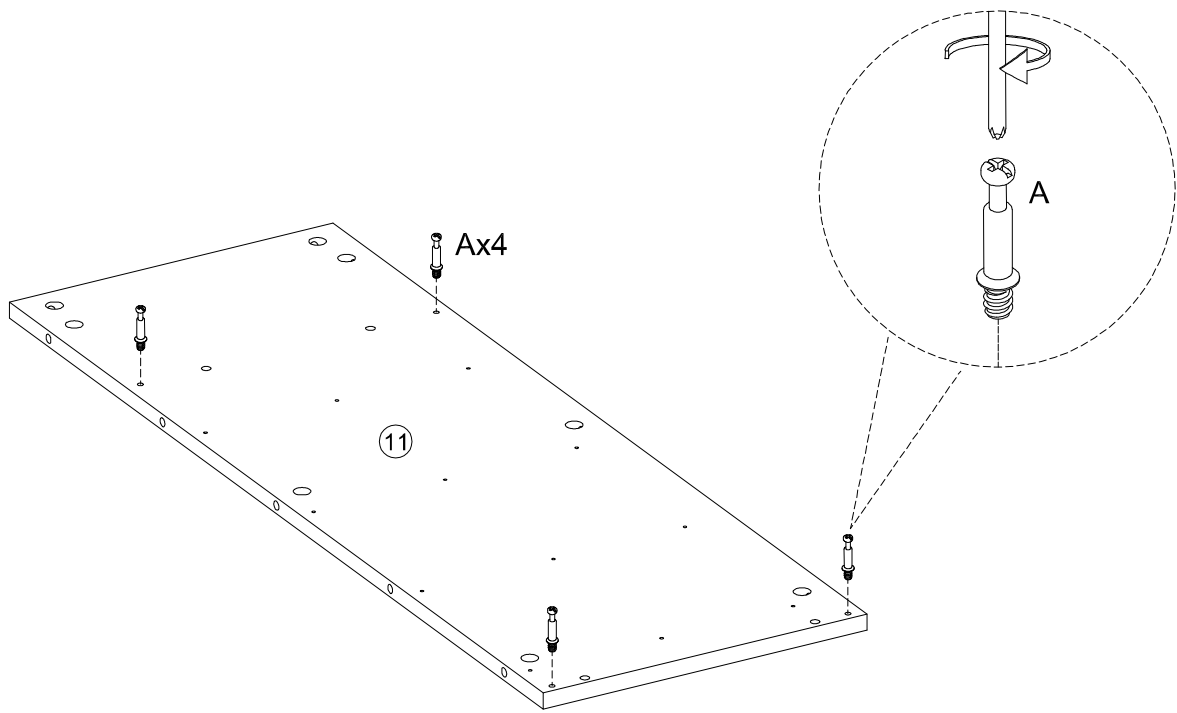
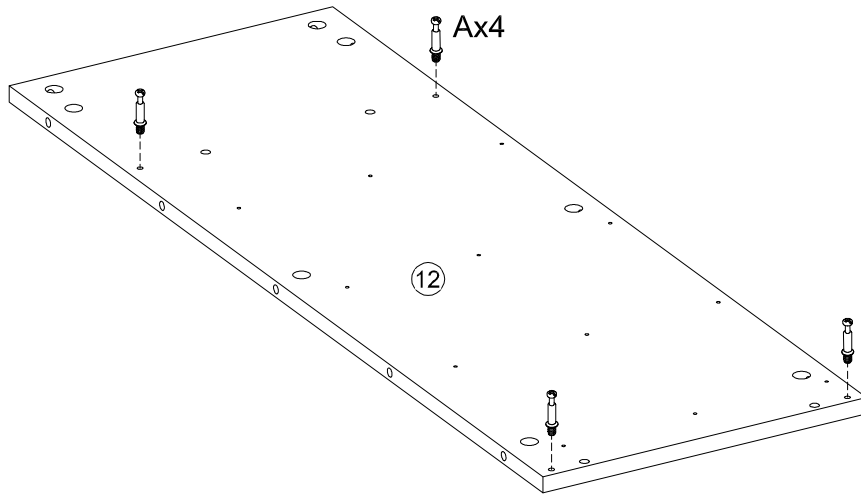

# 8



Dx8



Bx12

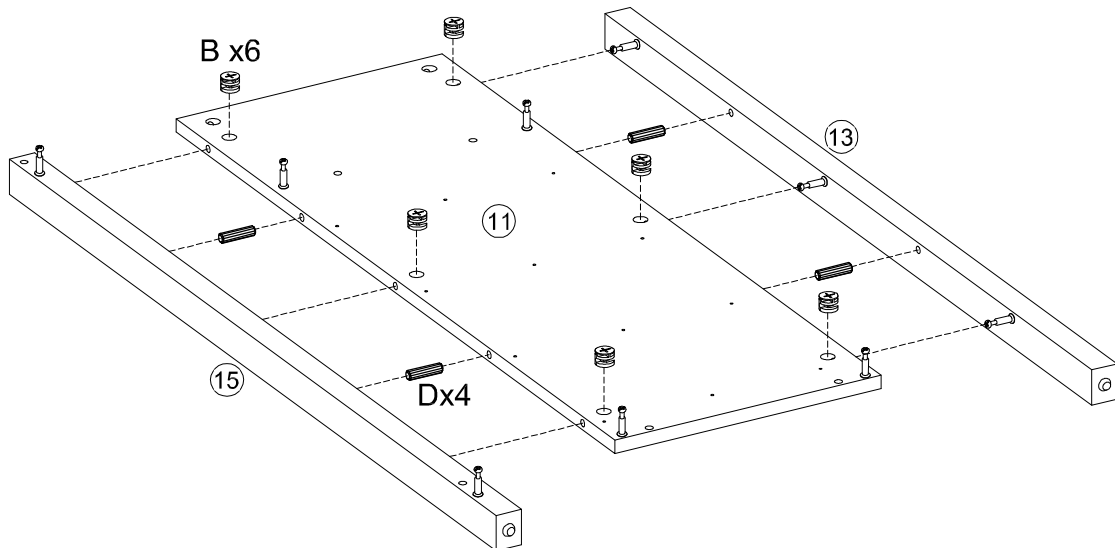
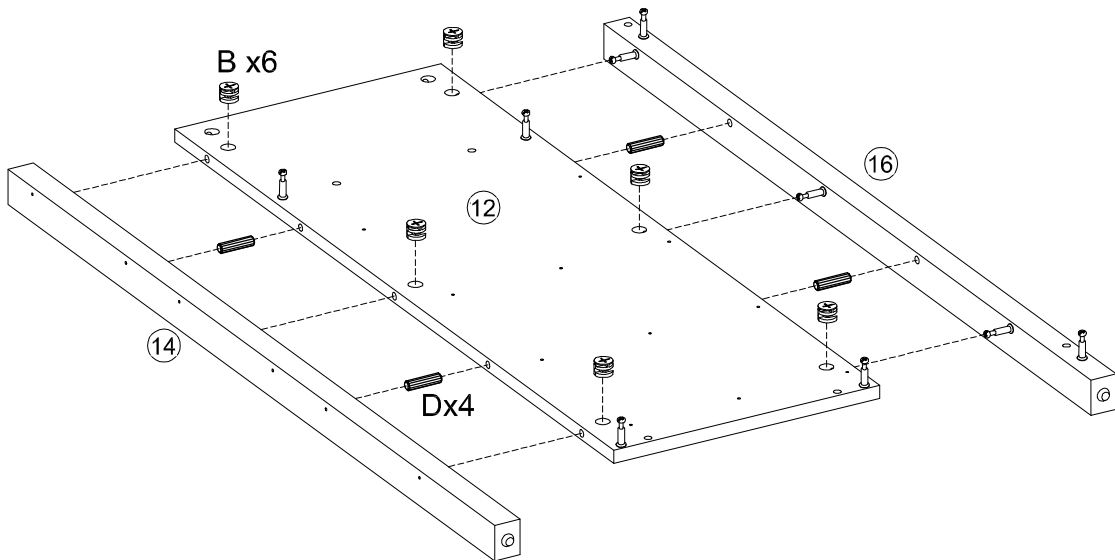
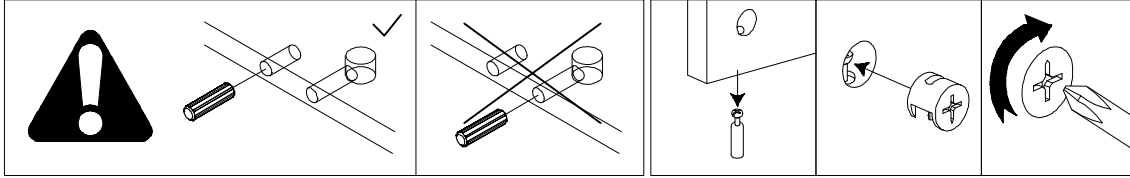

9

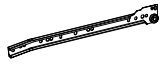

CRx4



Sx12

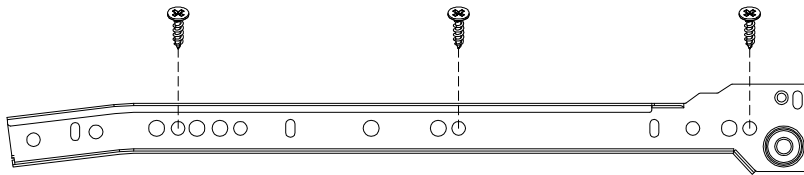

CR

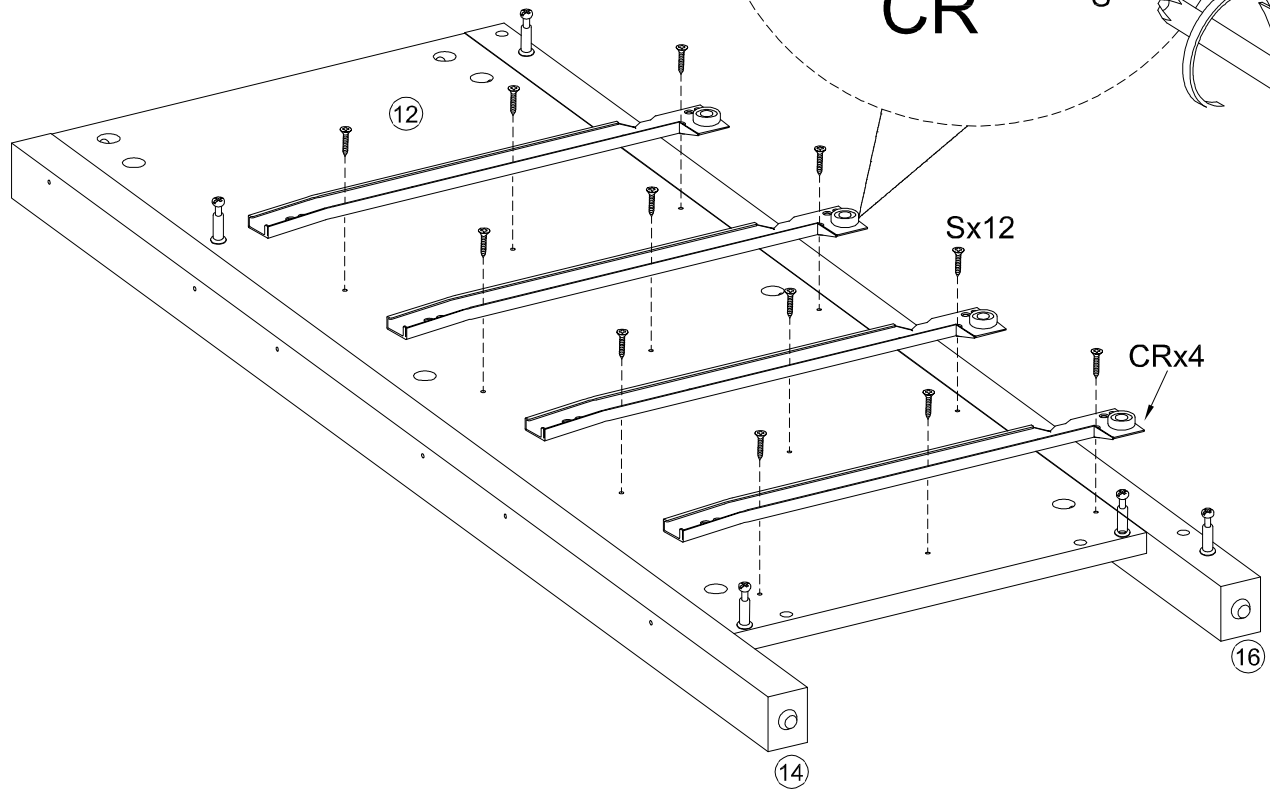
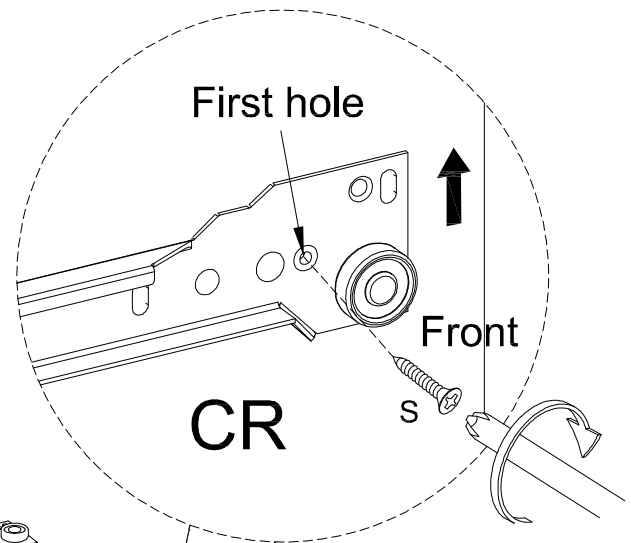

# 10



CLx4



Sx12

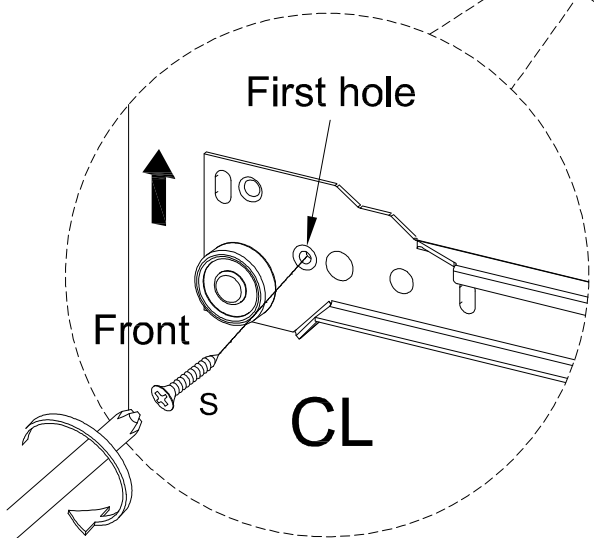
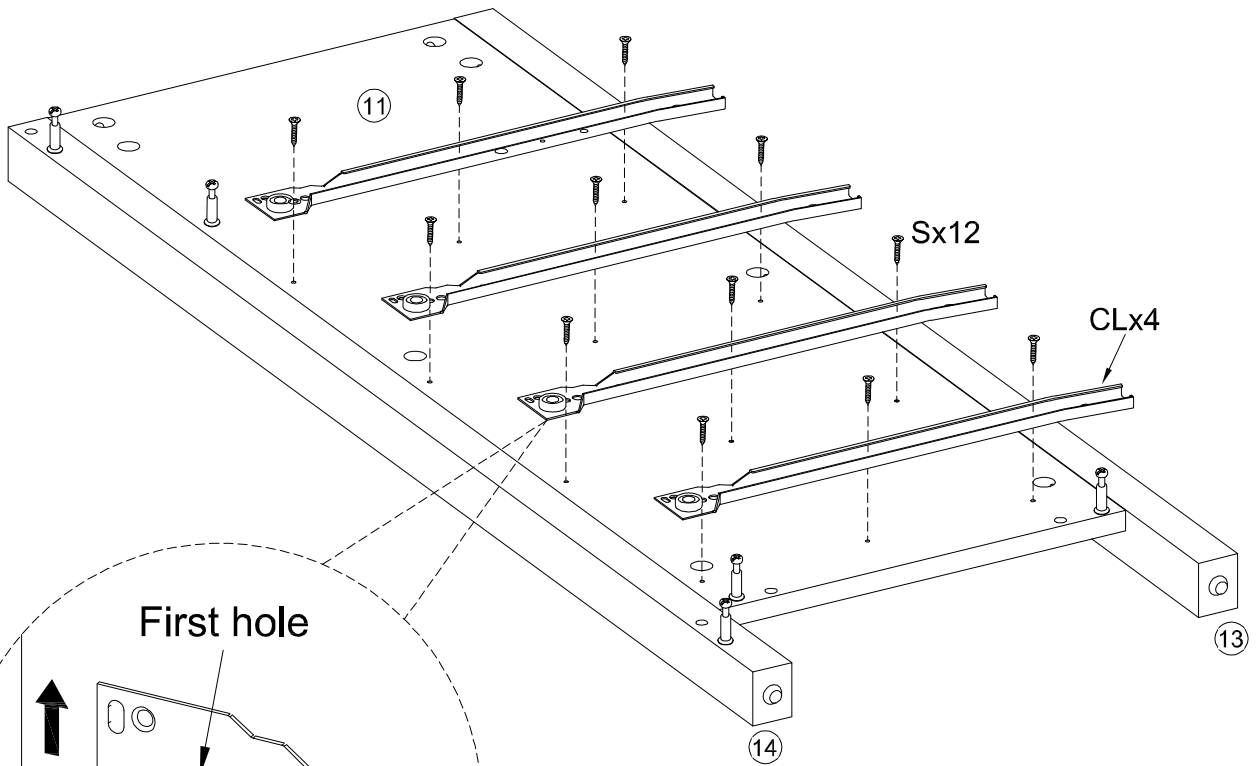
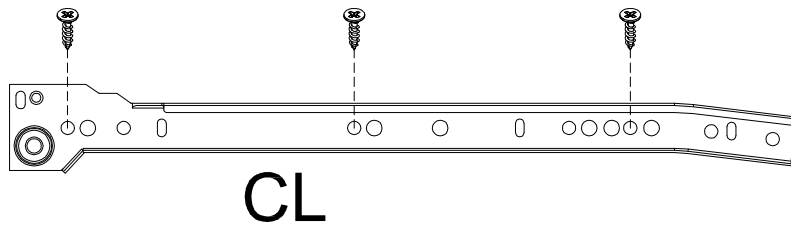

# 11

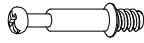

Ax6



Dx12



Bx12

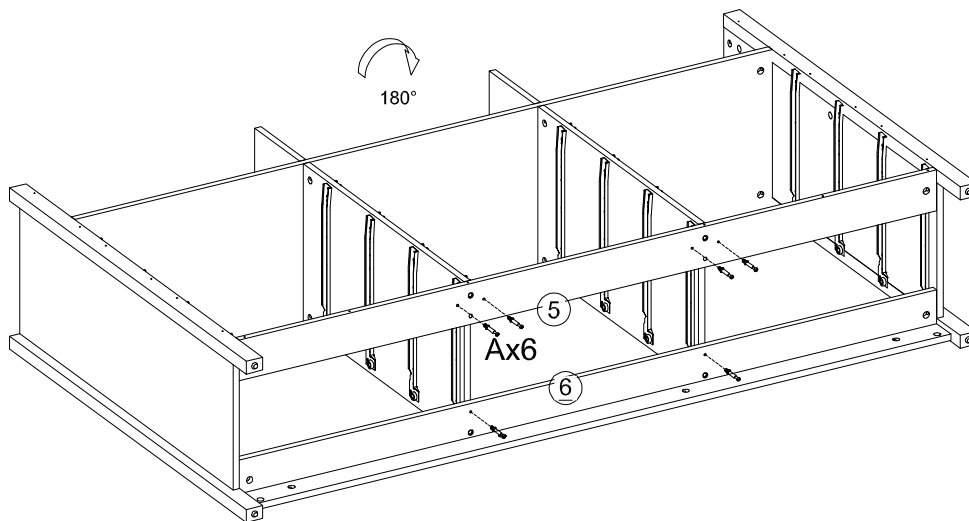
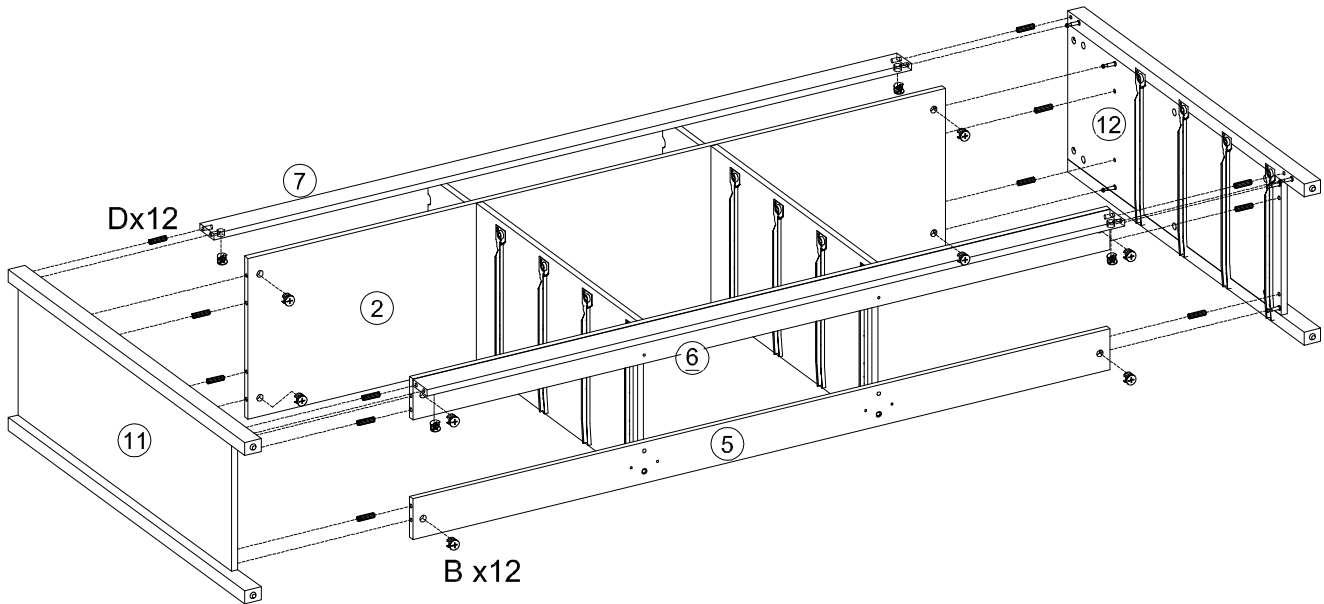
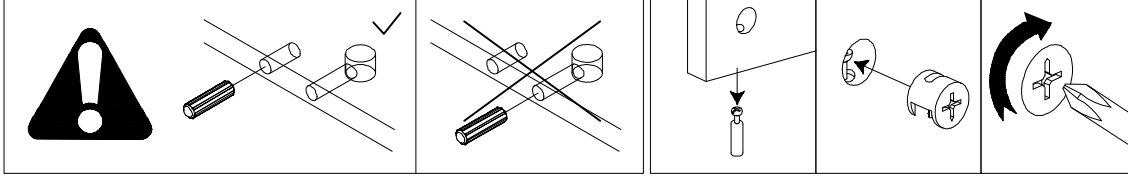

# 12



Dx4



Ex2



Bx6

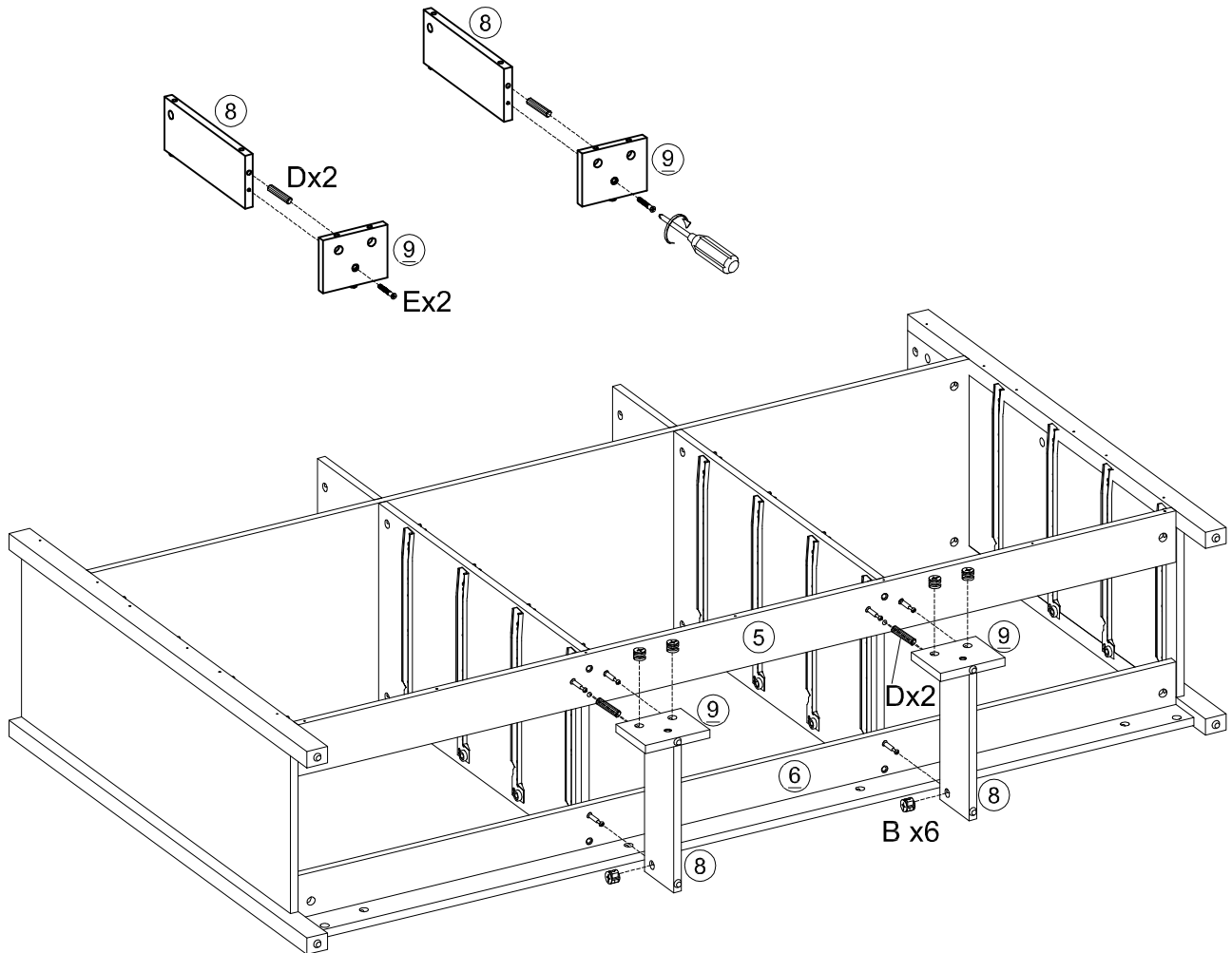
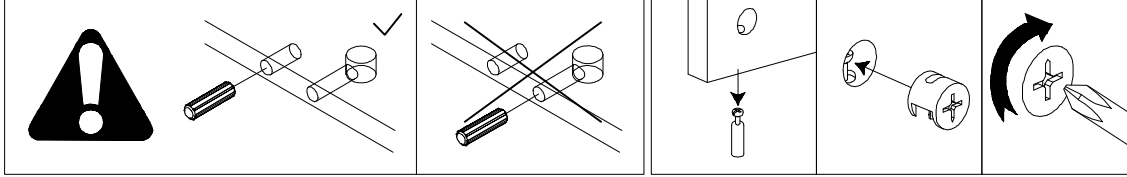

# 13

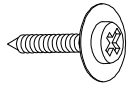

Fx31

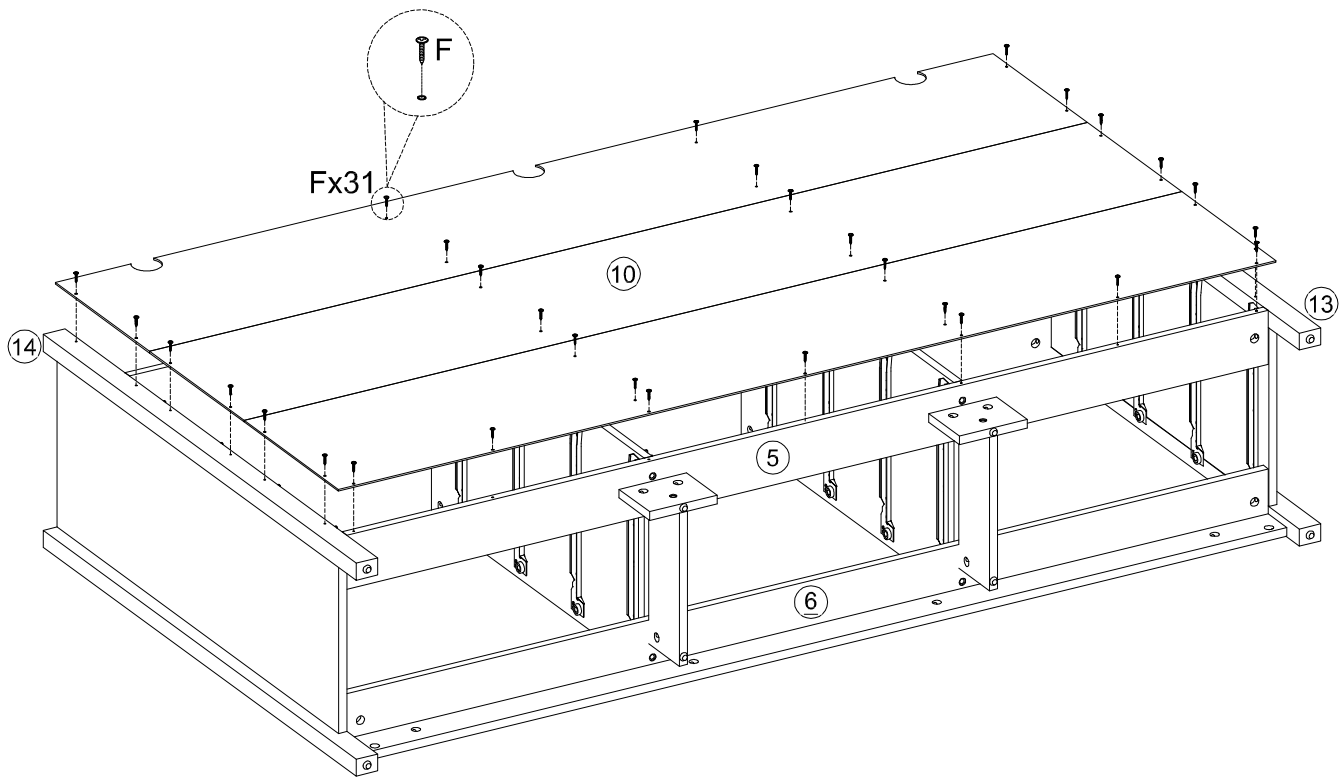

# 14



Qx1



Ix18

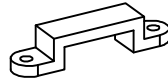

Jx9

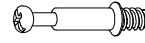

Ax12



Mx2



Kx2

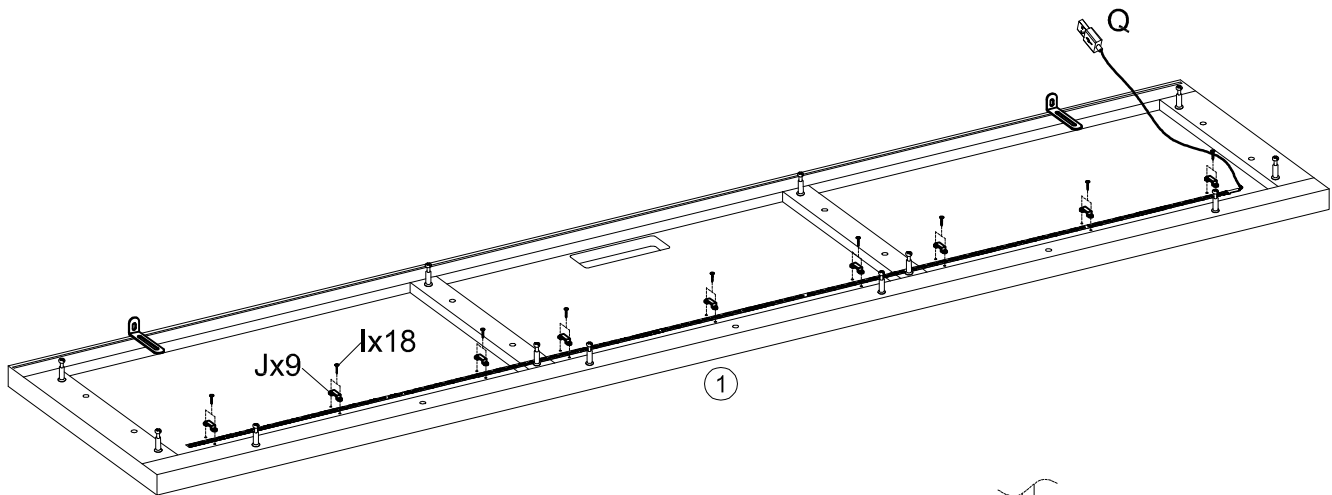
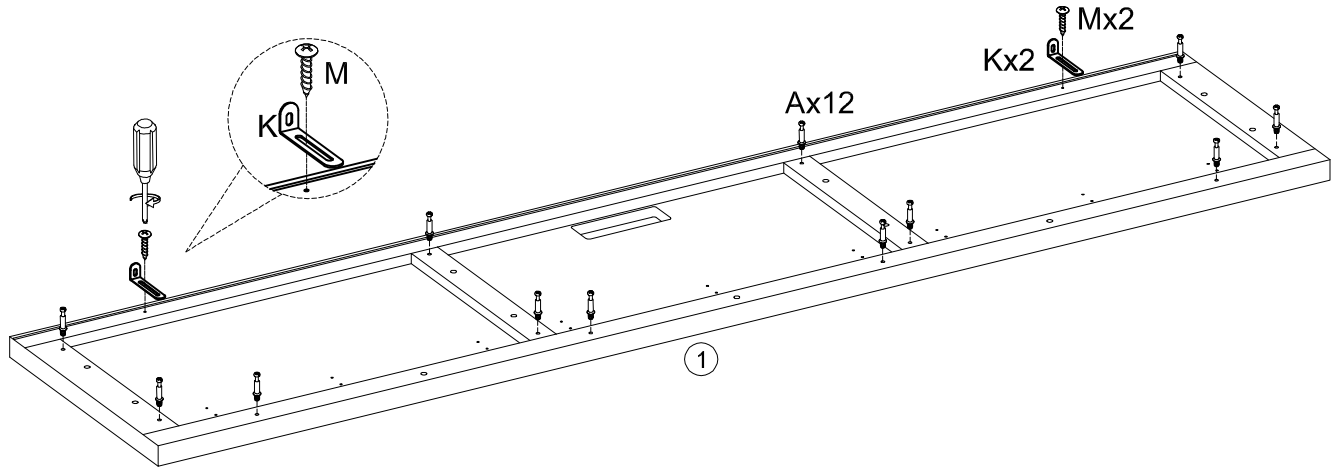

Remove the tape

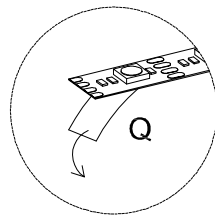

Press

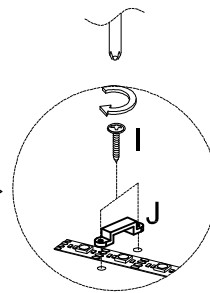
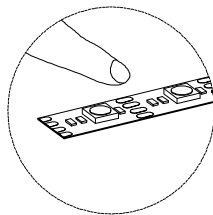

# 15



Dx11



Bx12

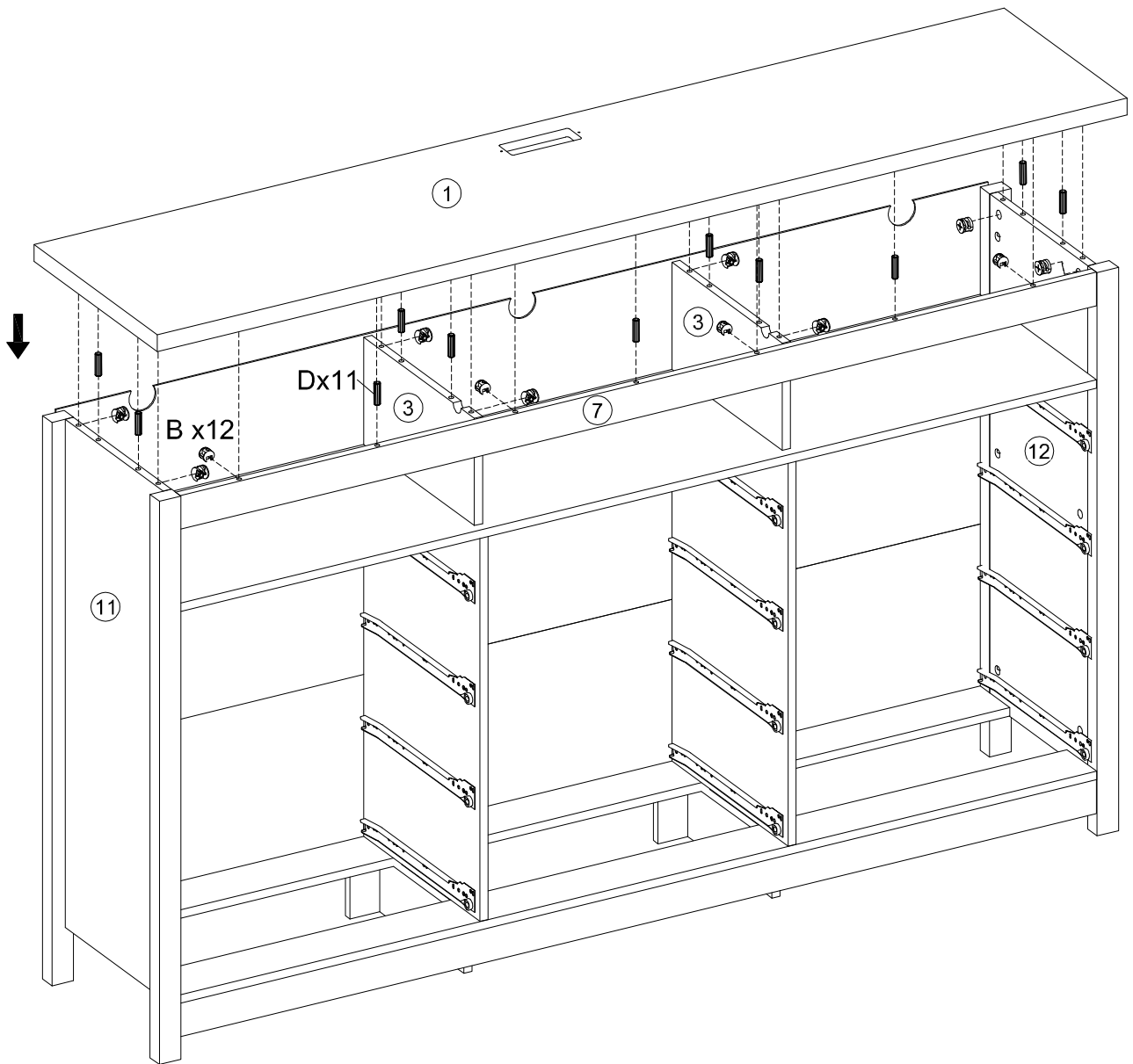
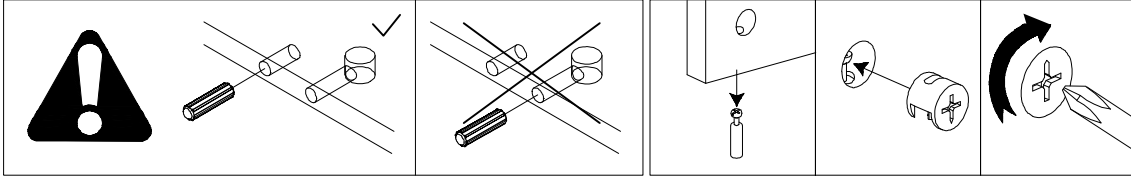

# 16

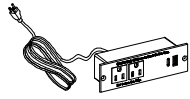

Rx1



Ix2

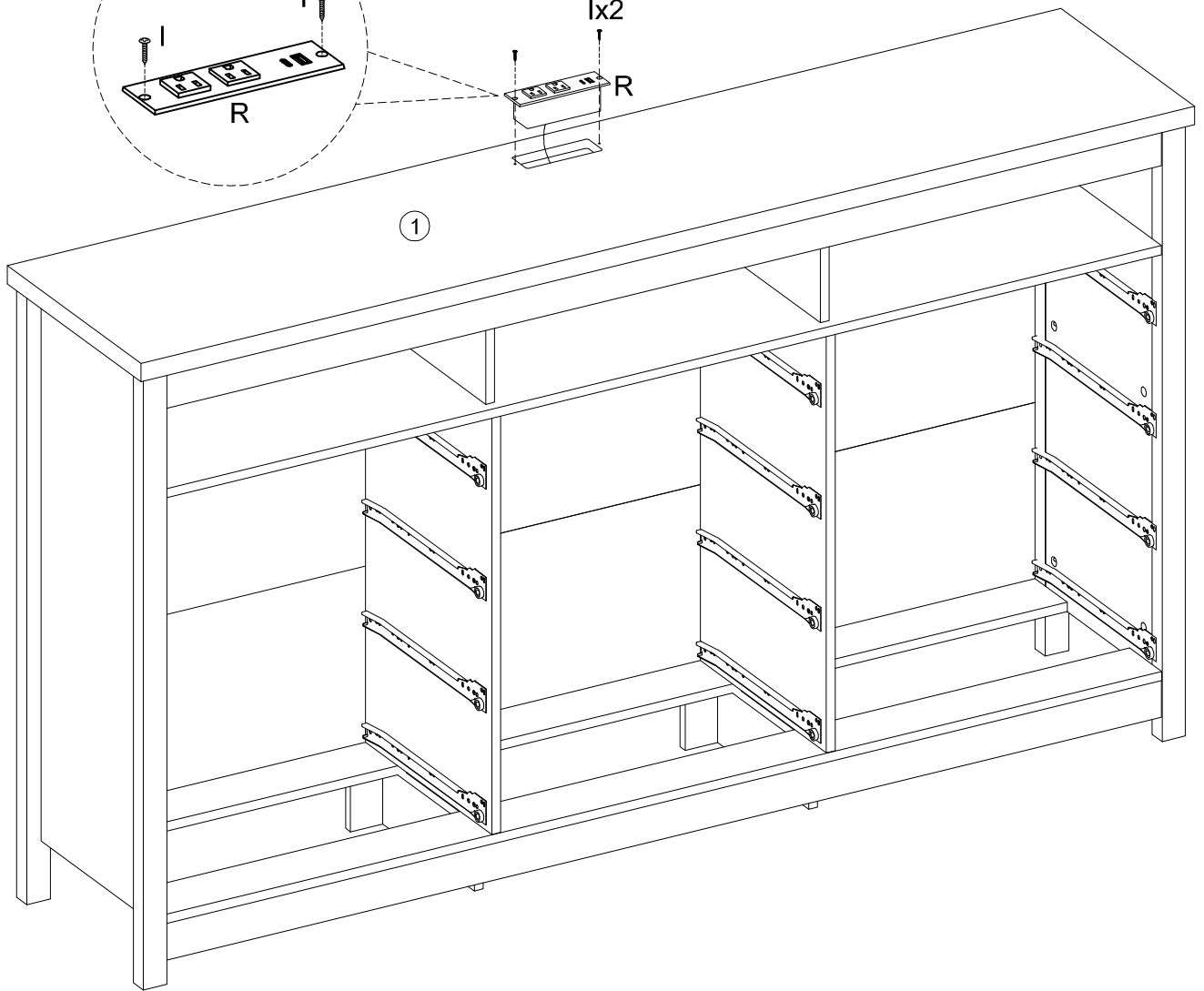
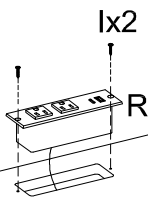
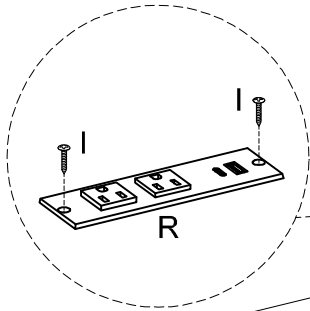

# 17



Lx2



Nx2

## WARNING

Serious or fatal injuries can occur from furniture tipping over. To prevent the furniture from tipping over we recommend that it is permanently fixed to the wall. Wall anchor and hardware are included with this product. Please make sure hardware is suitable for your walls before installing, as different wall materials may require different types of anchors.

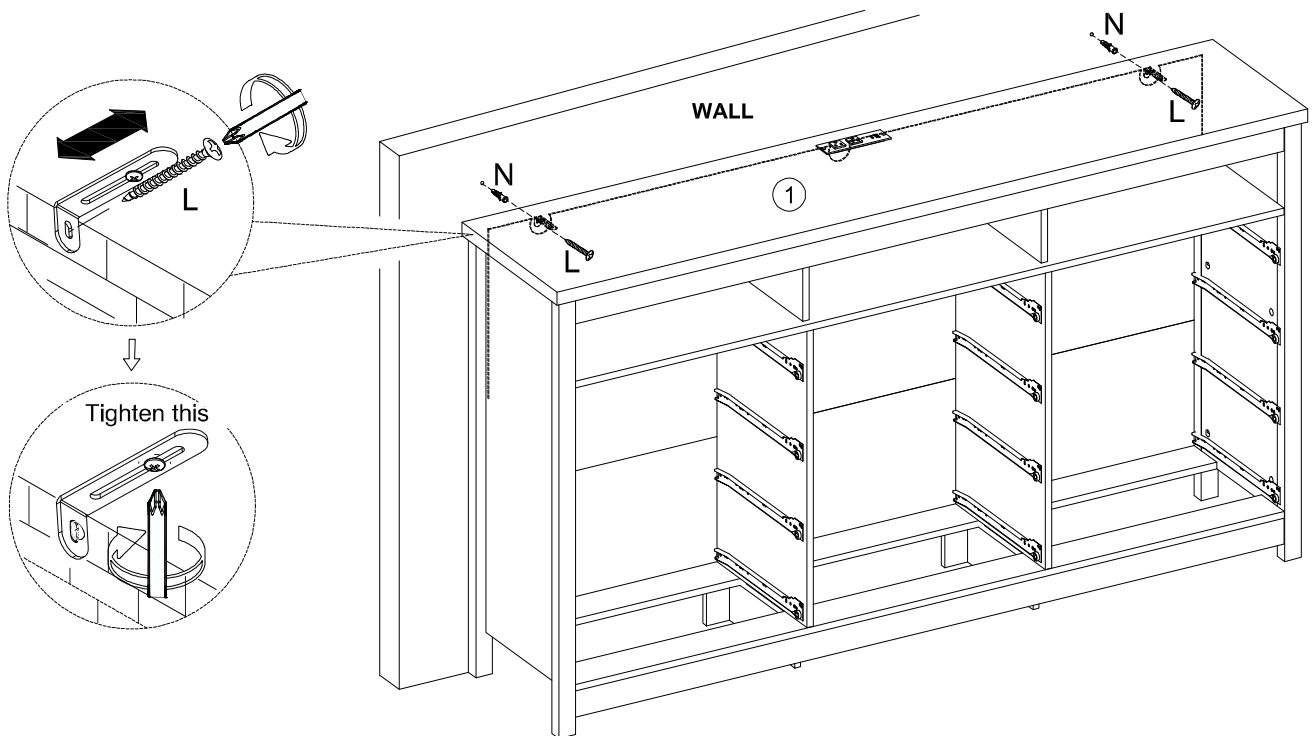
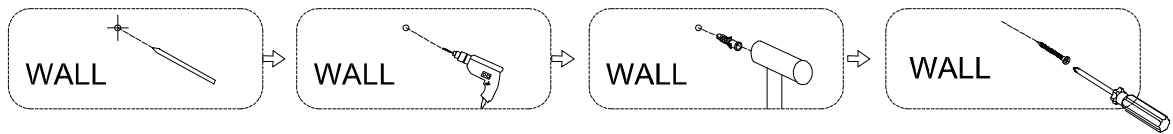

# 18

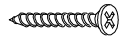

Px36

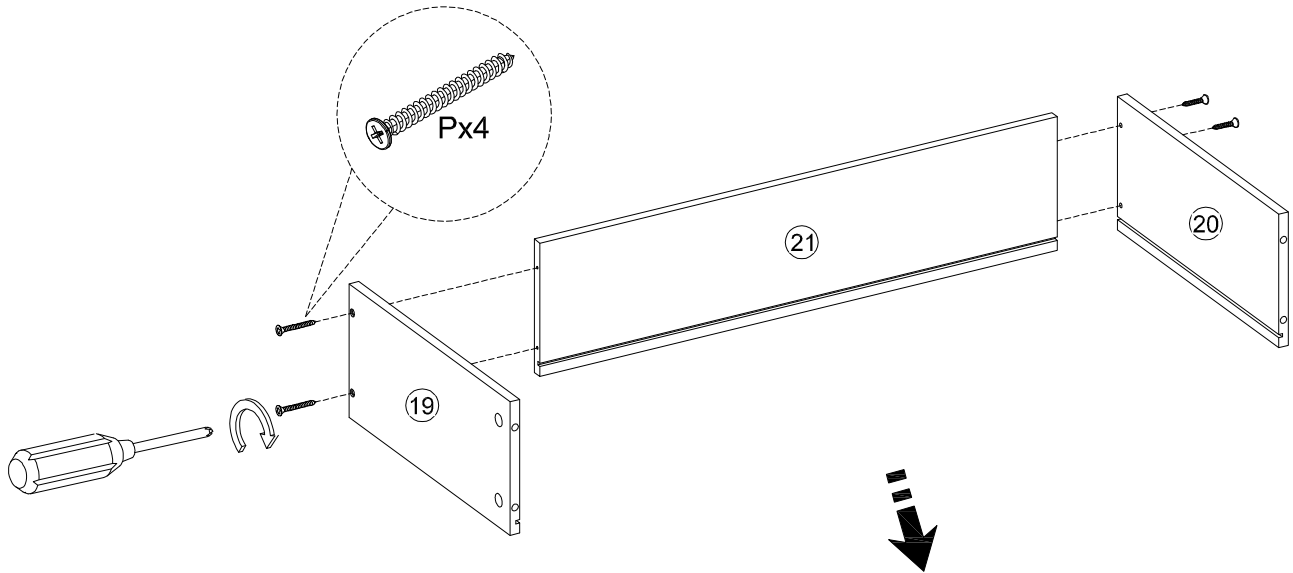

**X9**

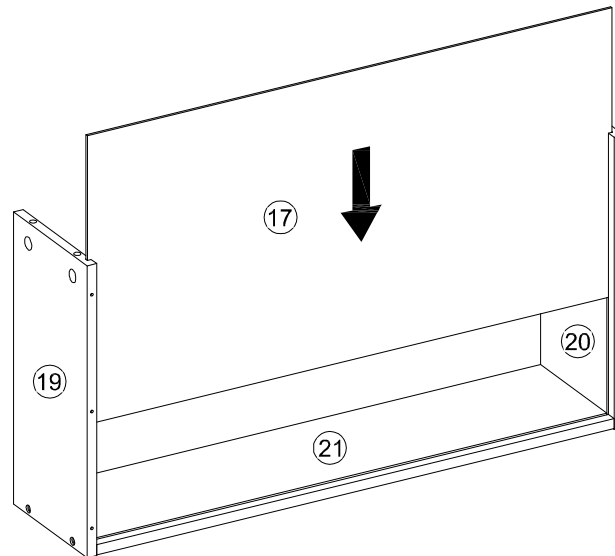

# 19



Ox36

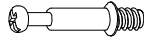

Ax36



Hx18



Gx9

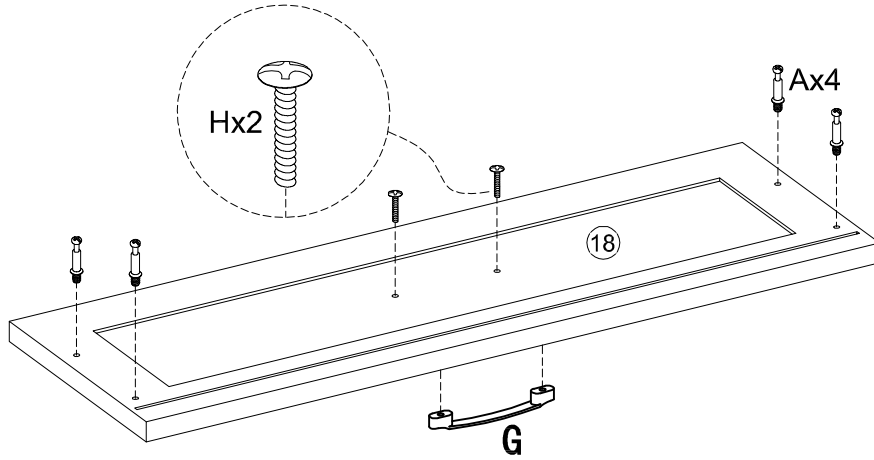

× 9

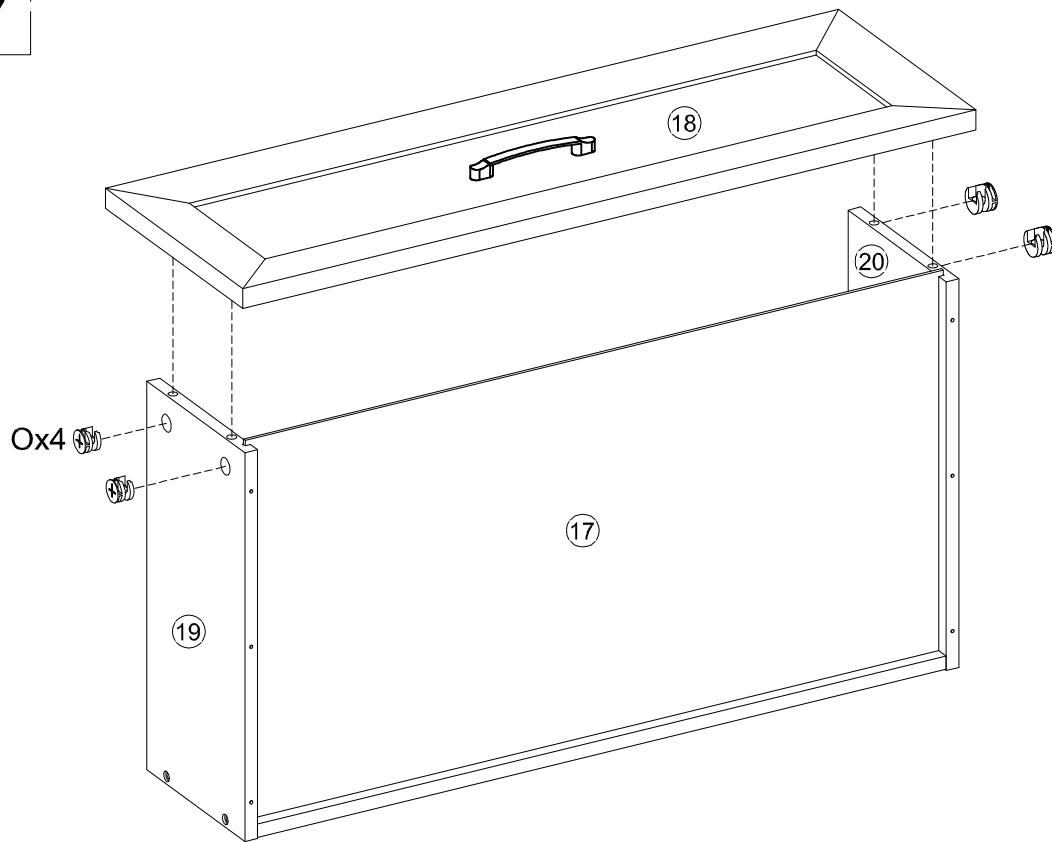

# 20



Sx54

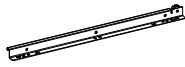

DLx9

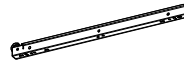

DRx9

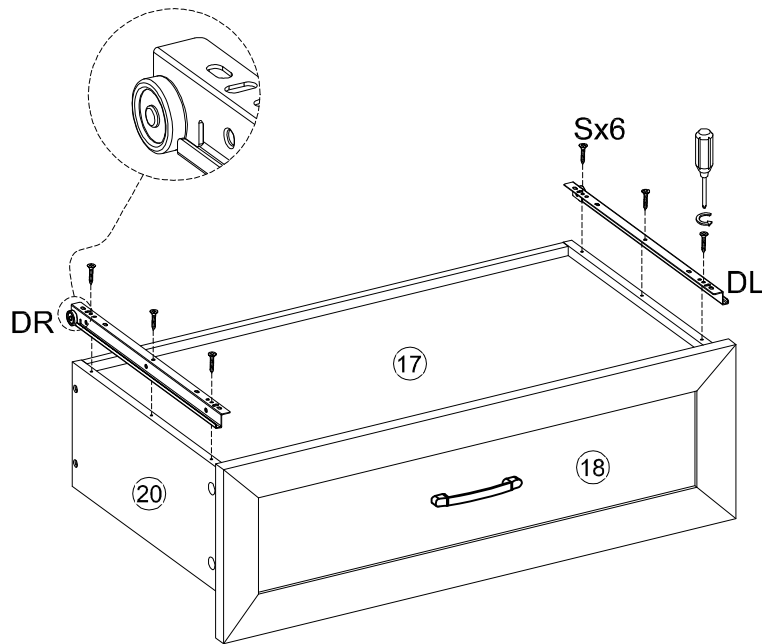

× 9

**Note the DL or DR stamped label on the track !**

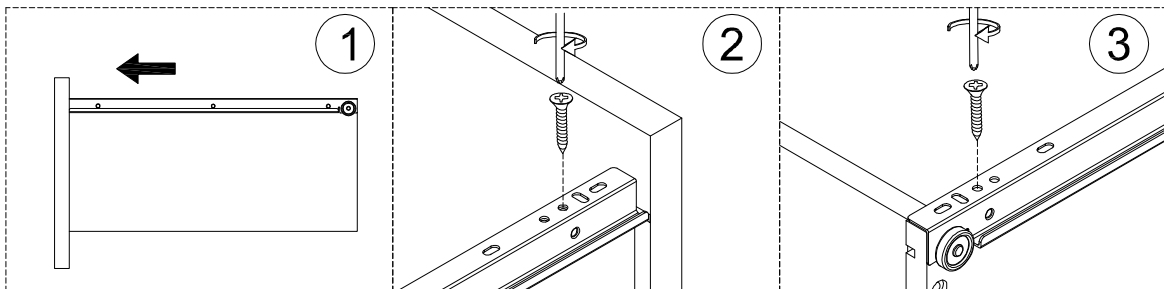

# 21



Px12

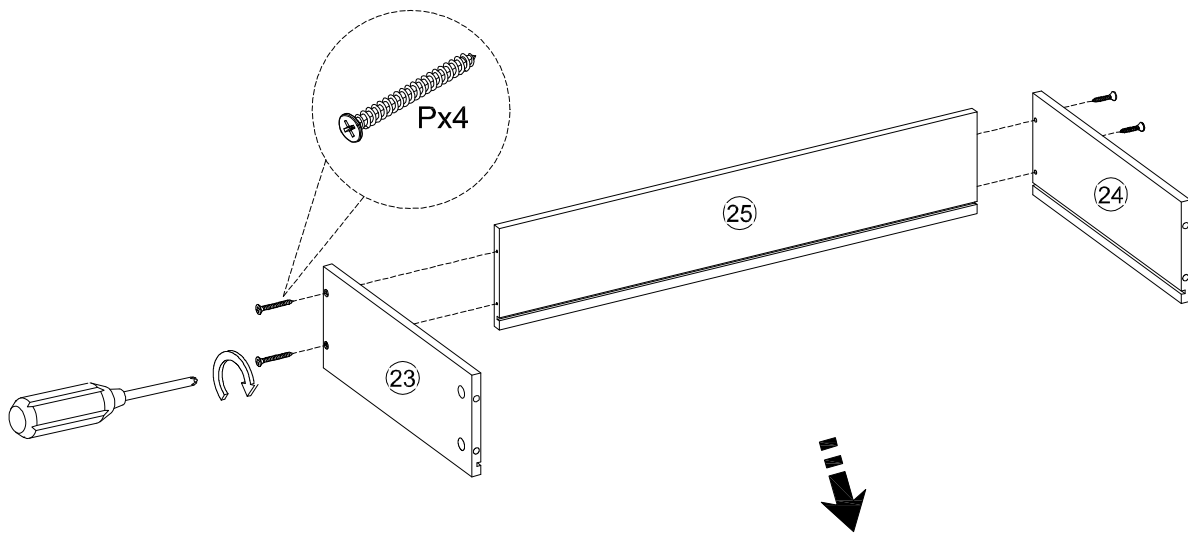

× 3

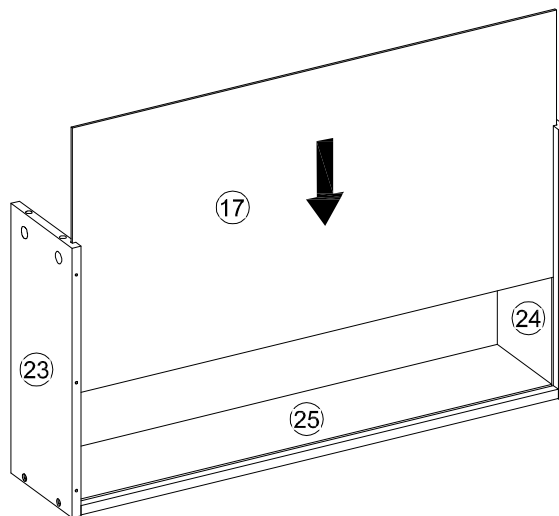

# 22



Ox12

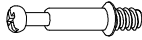

Ax12



Hx6



Gx3

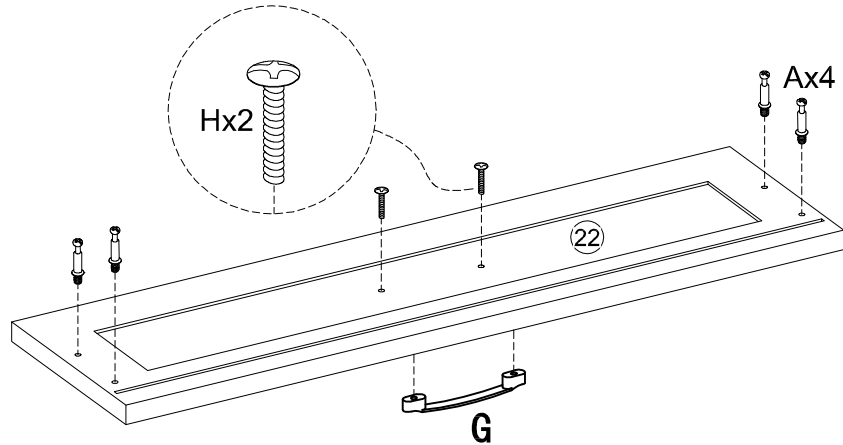

× 3

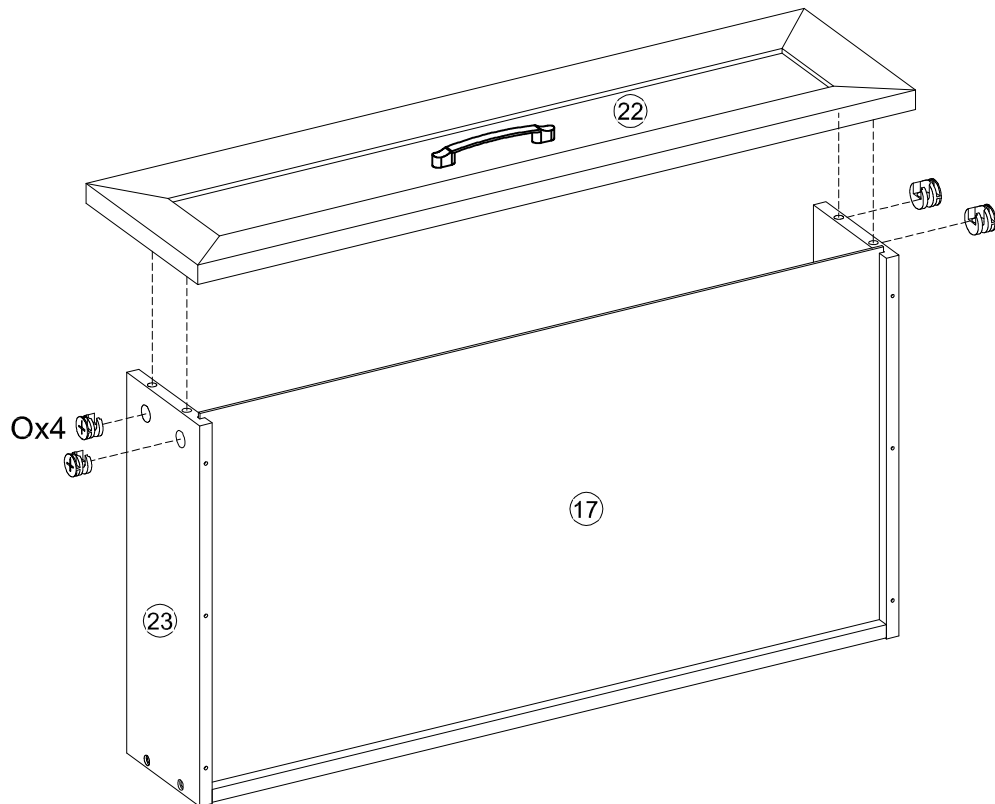

# 23



Sx18

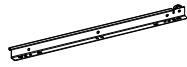

DLx3

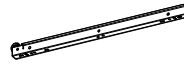

DRx3

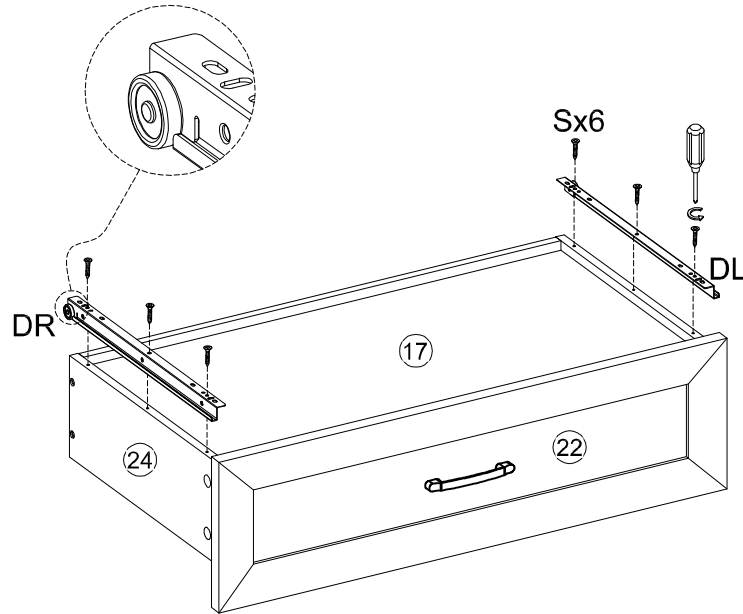

× 3

**Note the DL or DR stamped label on the track !**

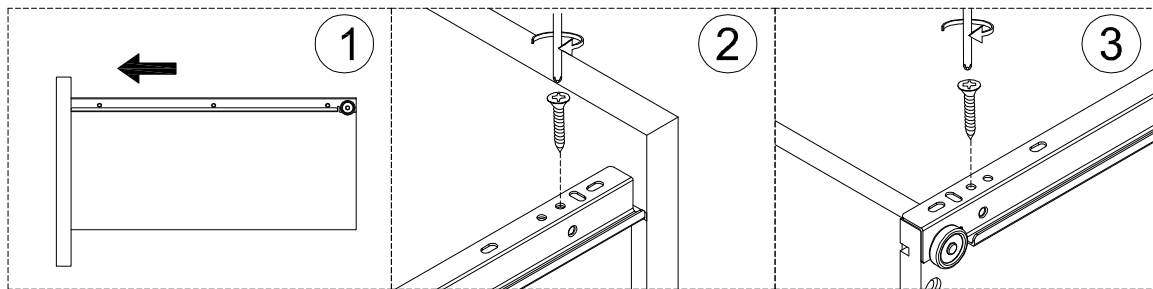

24

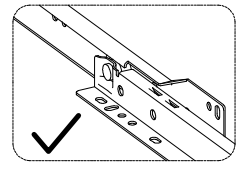
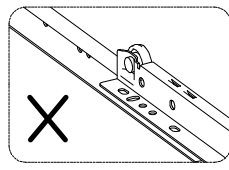
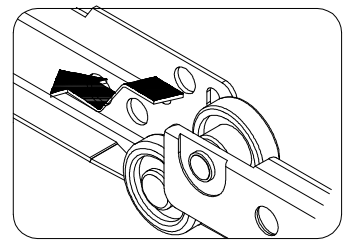
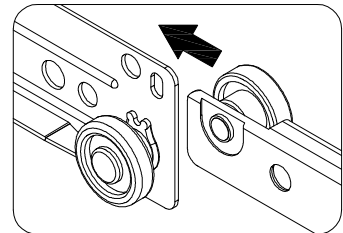

25



Cx98

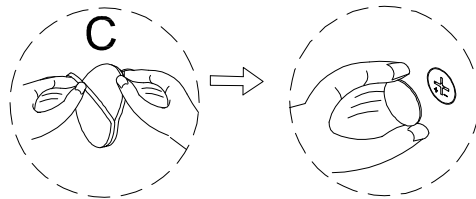

• Stick stickers (C) on cam locks (B,O).

Installation Completed

- a) The statement "Remove and immediately recycle or dispose of used batteries according to local regulations and keep away from children. Do NOT dispose of batteries in household trash or incinerate."
  - b) The statement "Even used batteries may cause severe injury or death."
  - c) The statement "Call a local poison control center for treatment information."
  - d) A statement indicating the compatible battery type (CR2025).
  - e) A statement indicating the nominal battery voltage (3~5V).
  - f) The statement "Non-rechargeable batteries are not to be recharged."
  - g) The statement "Do not force discharge, recharge, disassemble, heat above (manufacturer's specified temperature rating) or incinerate. Doing so may result in injury due to venting, leakage or explosion resulting in chemical burns."
- 
- a) The statement "Ensure the batteries are installed correctly according to polarity (+ and -)."
  - b) The statement "Do not mix old and new batteries, different brands or types of batteries, such as alkaline, carbon-zinc, or rechargeable batteries."
  - c) The statement "Remove and immediately recycle or dispose of batteries from equipment not used for an extended period of time according to local regulations."
  - d) The statement "Always completely secure the battery compartment. If the battery compartment does not close securely, stop using the product, remove the batteries, and keep them away from children."