

KNOW YOUR PIZZA OVEN

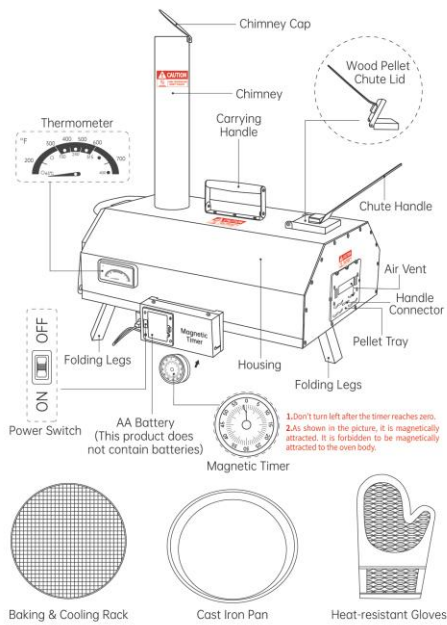

Actual product may differ slightly from illustrations on these pages

KNOW YOUR PIZZA OVEN

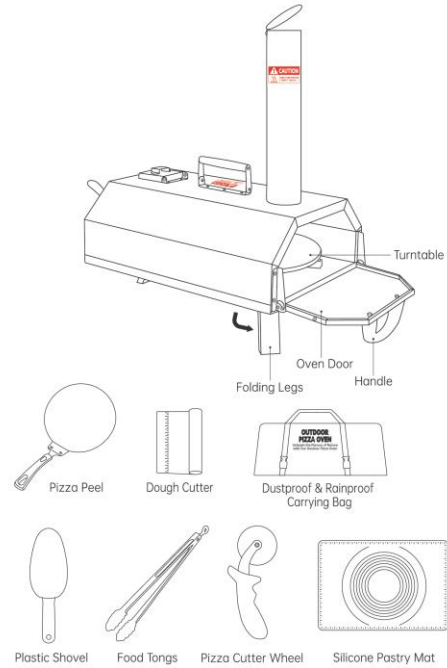

ASSEMBLY

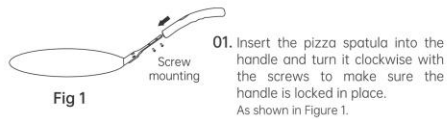

01. Insert the pizza spatula into the handle and turn it clockwise with the screws to make sure the handle is locked in place. As shown in Figure 1.

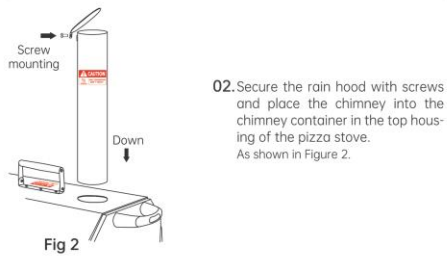

02. Secure the rain hood with screws and place the chimney into the chimney container in the top housing of the pizza stove. As shown in Figure 2.

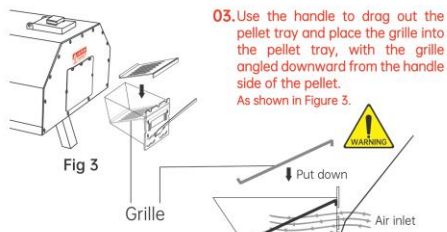

03. Use the handle to drag out the pellet tray and place the grille into the pellet tray, with the grille angled downward from the handle side of the pellet. As shown in Figure 3.

Tips: The particle grid is placed as shown to ensure ventilation

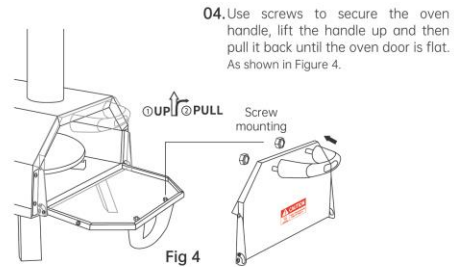

04. Use screws to secure the oven handle, lift the handle up and then pull it back until the oven door is flat. As shown in Figure 4.

LIGHTING YOUR PELLETS

- Place approximately 1.5 cups of pellets into the Pellet Tray. The pellets should be loaded into the lower side of the Pellet Tray. Do not overfill the Pellet Tray as this will cover the air holes on the Pellet Grate.
- Place a Firestarter designed for grills on top of the pellets. Do not use Firestarters designed for fire pits or chimneys as these would create an overwhelming unnatural taste to your food.
- Light the Firestarter then place the Pellet Tray inside the Housing.
- The Oven Door should always be in place on the oven unless adding or removing food. To place the Oven Door on the Housing, ensure the top of the Oven Door is nested behind the Door Clip on the top of the Housing, then swing the bottom of the Oven Door until it nests against the Housing.
- The Pellet Chute should always be closed unless adding additional pellets.
- A full Pellet Tray will take approximately 15 minutes to burn through. Always check the Pellet Chute and refill as necessary to keep a constant flame. While cooking, never let the Pellet Tray extinguish.