

Coffee Table

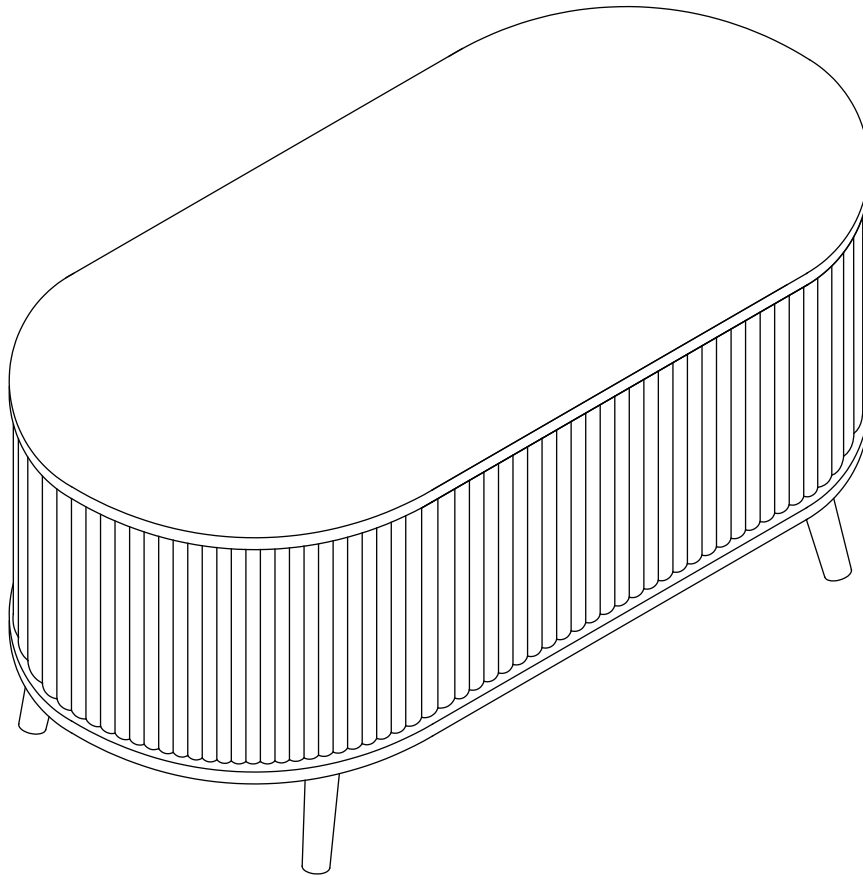

Please make sure to read the instruction manual carefully before installing the product.

Do Not Return This Product!

Contact our customer service team
for help first.



WARNING

- Unit can tip over causing severe injury or death.
- Anchor unit to stud in wall (if instructed to)
- Do Not allow children to climb on unit.
- put heavy items on lower shelves or drawers.

**PEOPLE NEEDED
FOR ASSEMBLY:2**

CONTACT US!

Do NOT return this product!

Contact our friendly customer service team first for help.

- Open your item in the area you plan to keep it to avoid excessive heavy lifting.
- Identify, sort and count the parts before attempting assembly.
- Back panel must be used to make sure your unit is sturdy.
- Do NOT use harsh chemicals or abrasive cleaners on this item.
- Never push,pull,or drag your furniture.







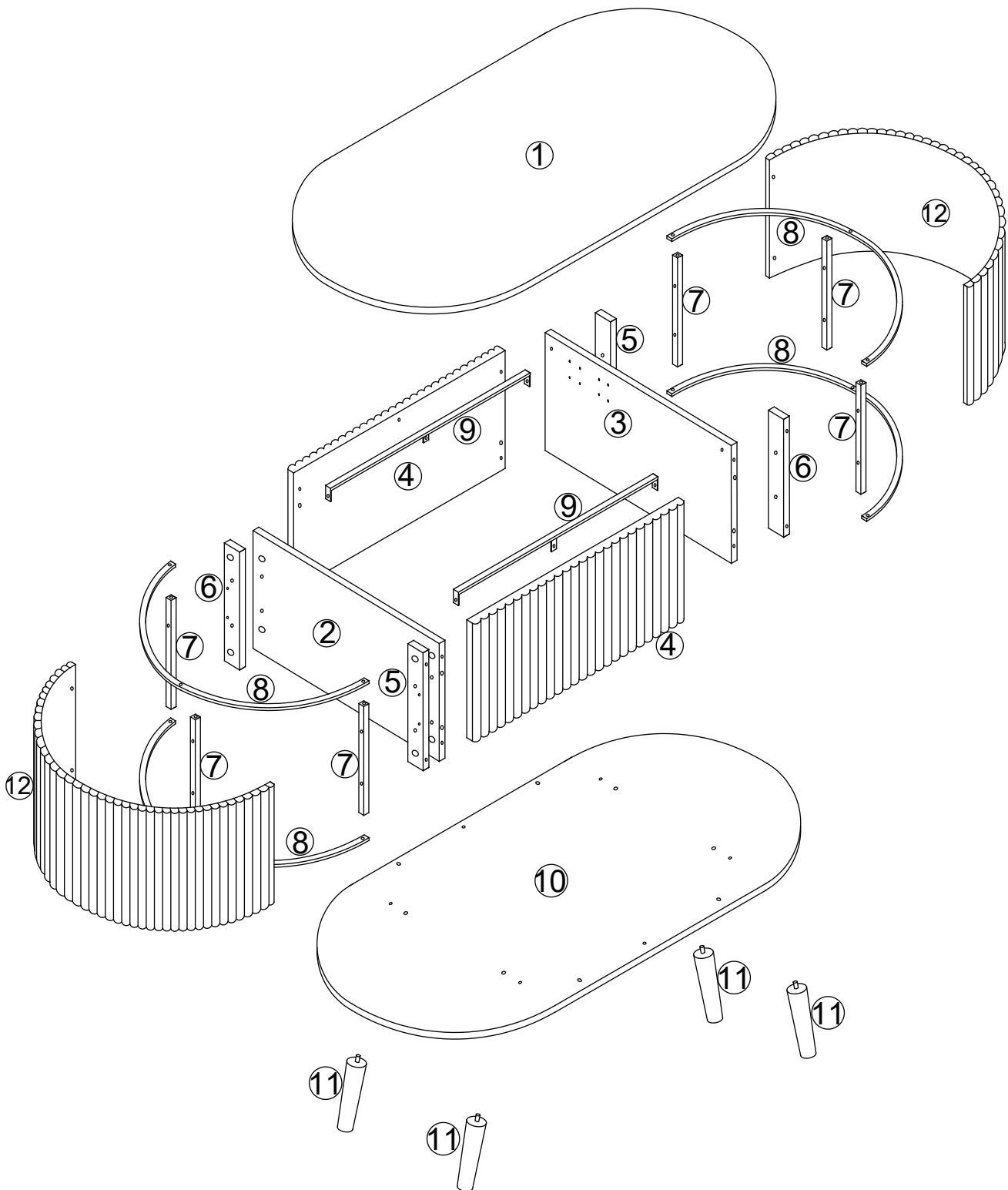

BEFORE YOU START

- Read through each step carefully and follow the proper order
- Separate and count all your parts and hardware
- Give yourself enough room for the assembly process
- Have the following tools:Flat Head Screwdriver,#2 Phillips Head Screwdriver and Hammer
- Caution: IF using a power drill or power screwdriver for screwing,please be aware to slow down and stop when screw is tight.Failure to do so may result in stripping the screw.

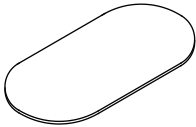
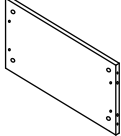
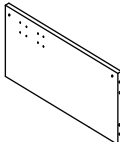
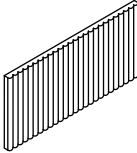

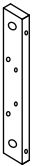

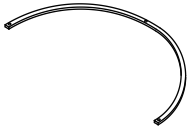
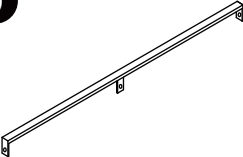
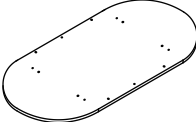

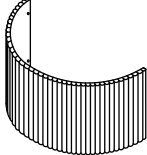



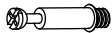





BOARD IDENTIFICATION



BOARD IDENTIFICATION

1  1PC	2  1PC	3  1PC	4  2PCS
5  2PCS	6  2PCS	7  6PCS	8  4PCS
9  2PCS	10  1PC	11  4PCS	12  2PCS

THE HARDWARE

A x16	B x16	C x18	D x8	E x4
				
Bolt	Bolt	Wood Dowel	Screw	Screw
Ø6x35mm	Ø15x9.5mm	Ø6x30mm	Ø4x25mm	Ø7x40mm
F x6	G x16	H x1	I x4	J x1
				
Screw	Cam Cover	Hex Key	Adjustable foot nail	Elevator
Ø4x12mm	Ø20mm	4mm		
K x1	L x4	M x6	N x8	O x44
				
Elevator	Five hole iron sheet	Screw	Screw	Screw
		Ø6x16mm	Ø4x25mm	Ø4x14mm
P x6				
				
Screw				
Ø6x35mm				

IMPORTANT :

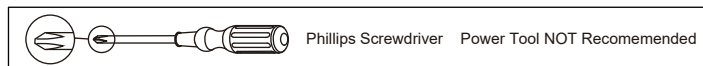

1. Do not tighten bolts / screws completely until all bolts / screws are lined up and inserted into holes.
2. Do not over tighten screws and bolts to avoid stripping.
3. Please use hand tools to assemble this product. Do not use power tools.

CAM LOCK FASTENING SYSTEM

This Cam Lock Fastening System will be used throughout the assembly process.

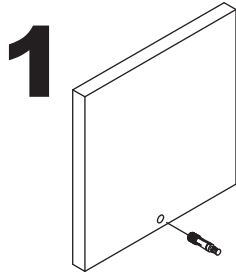

1 Press CAM BOLT into hole.

2

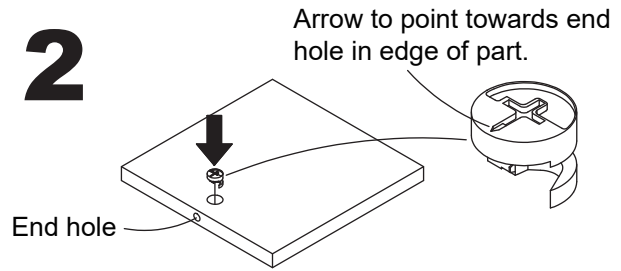

Press CAM LOCK into hole.

3

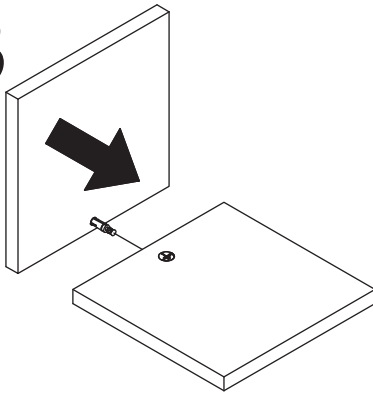

Press parts together so CAM BOLT inserts into edge hole.

4

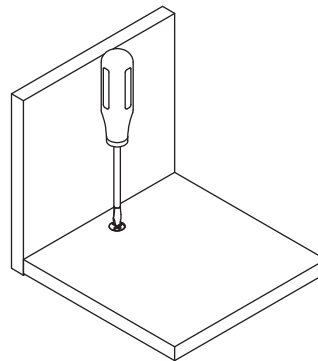

Using a screwdriver, turn the CAM LOCK clockwise to lock the CAM LOCK and CAM BOLT into their holes and fastening parts together.

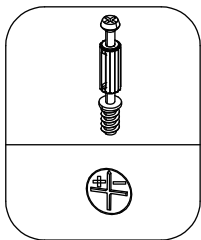

Notice: Proper orientation of CAM LOCK

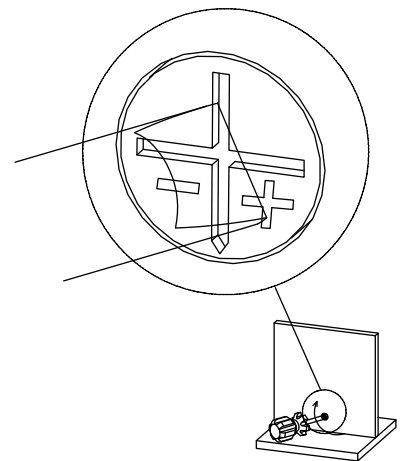
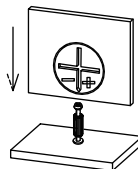
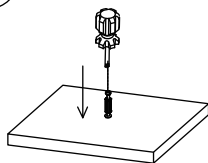
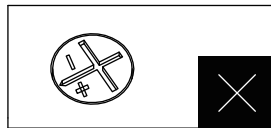
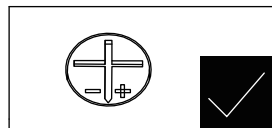

It may be necessary to adjust the hinges so that the doors align. Use the instructions below as a guide.

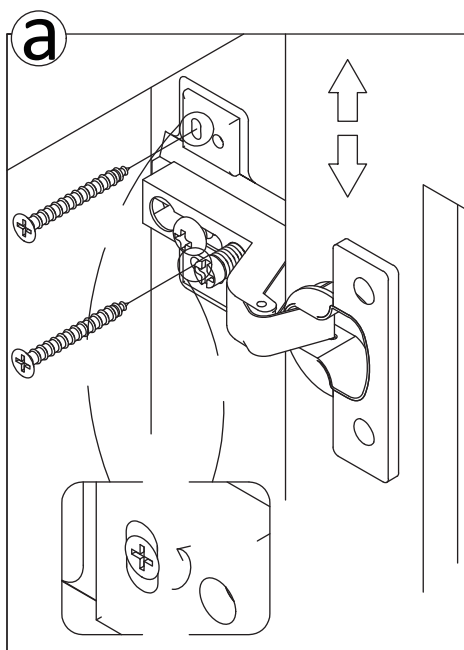

To adjust the door vertically loosen the screw as shown and move up and down as needed.

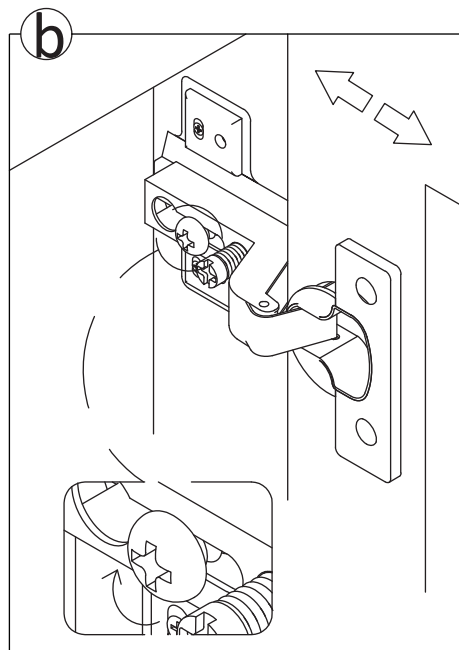

To adjust the gap from the door to the main frame turn the screw clockwise or anticlockwise as needed.

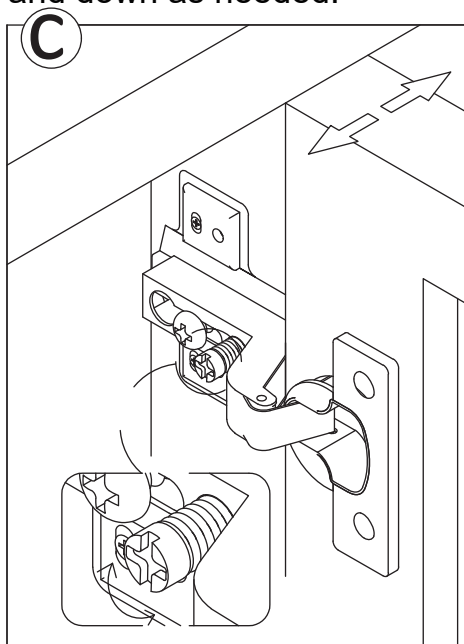

To adjust the door laterally (such as changing the gap between the two doors), please adjust the screw as shown by turning clockwise or anticlockwise.

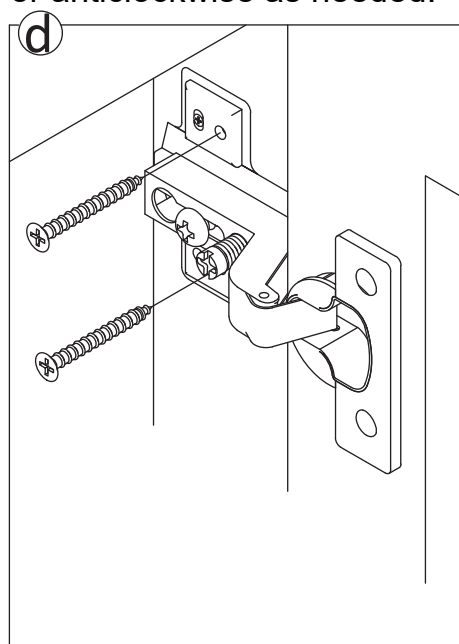

Please fix other screws.

INSTALLATION STEPS

STEP 1

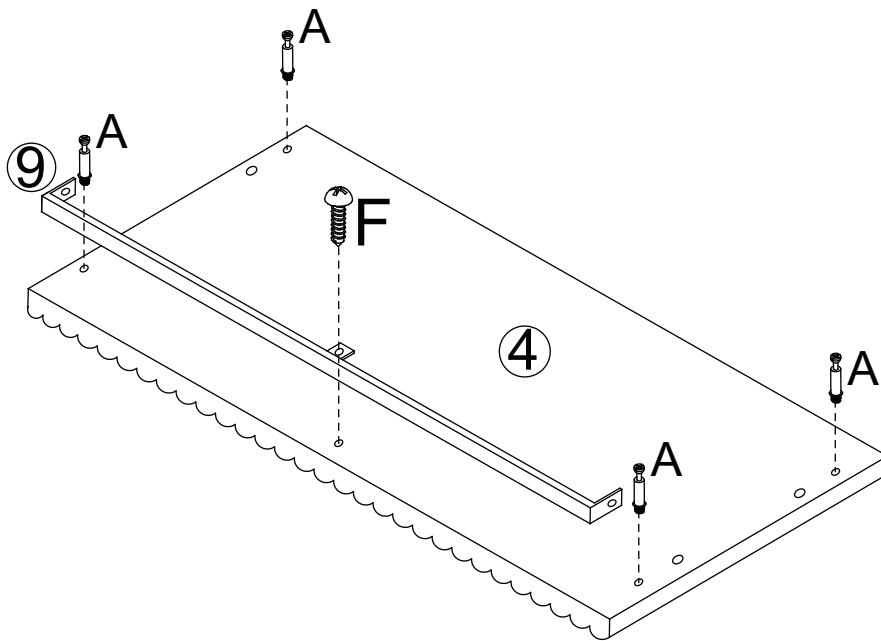
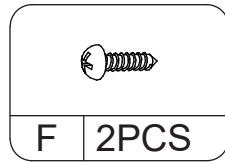
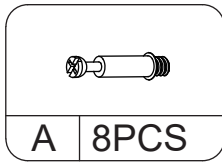

X2

INSTALLATION STEPS

STEP 2

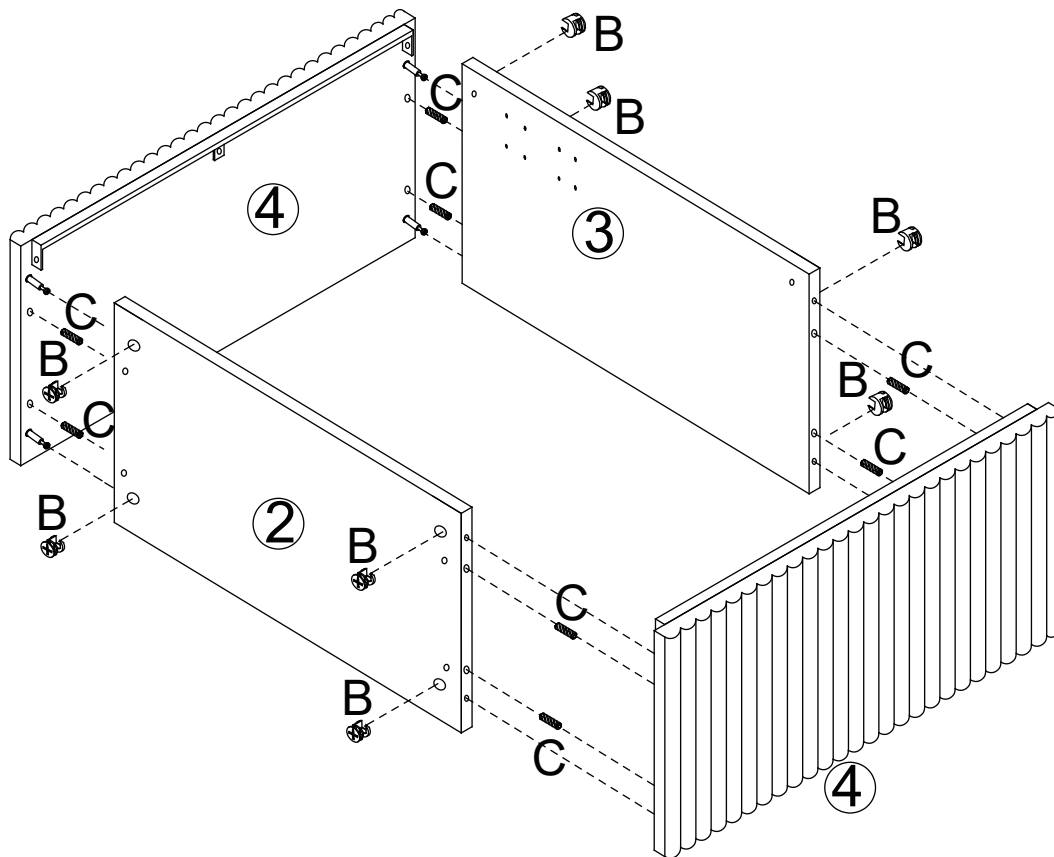
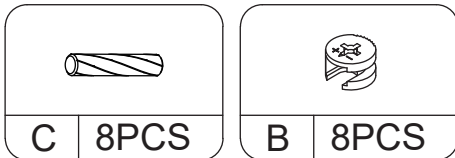

INSTALLATION STEPS

STEP 3

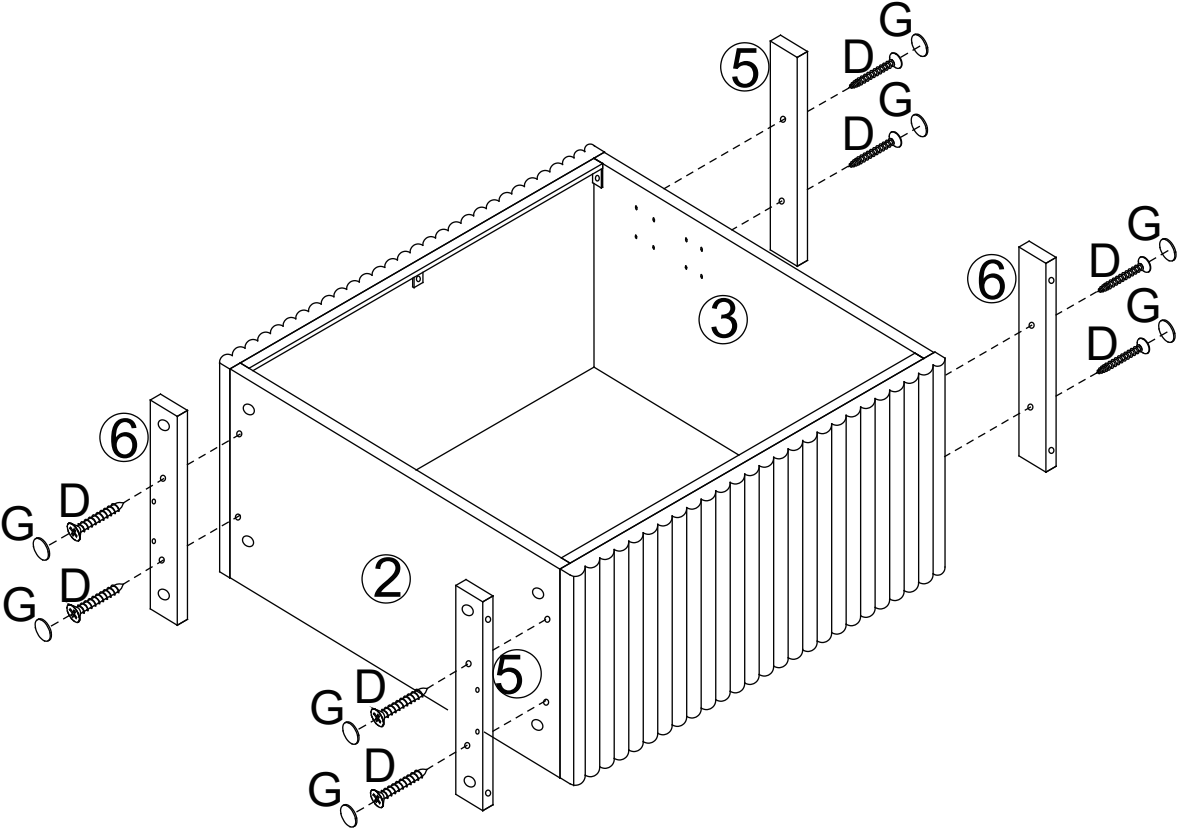
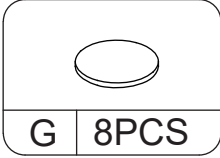
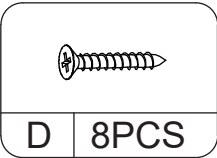

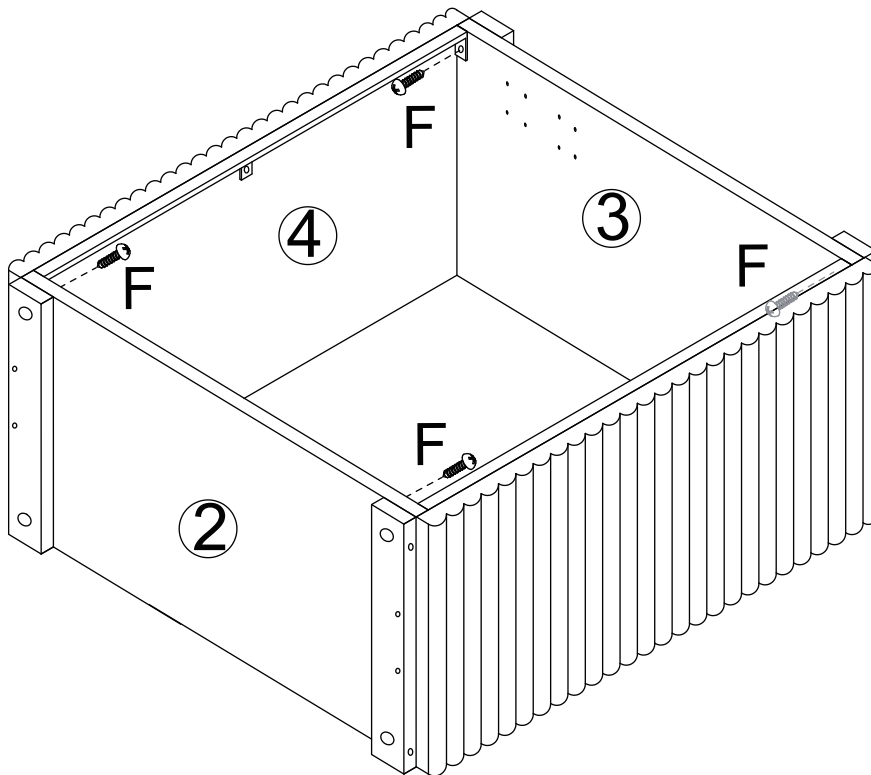
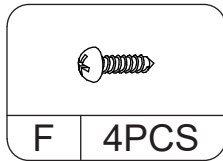

INSTALLATION STEPS

STEP 4

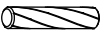

INSTALLATION STEPS

STEP 5

		
C 10PCS	E 4PCS	H 1PC

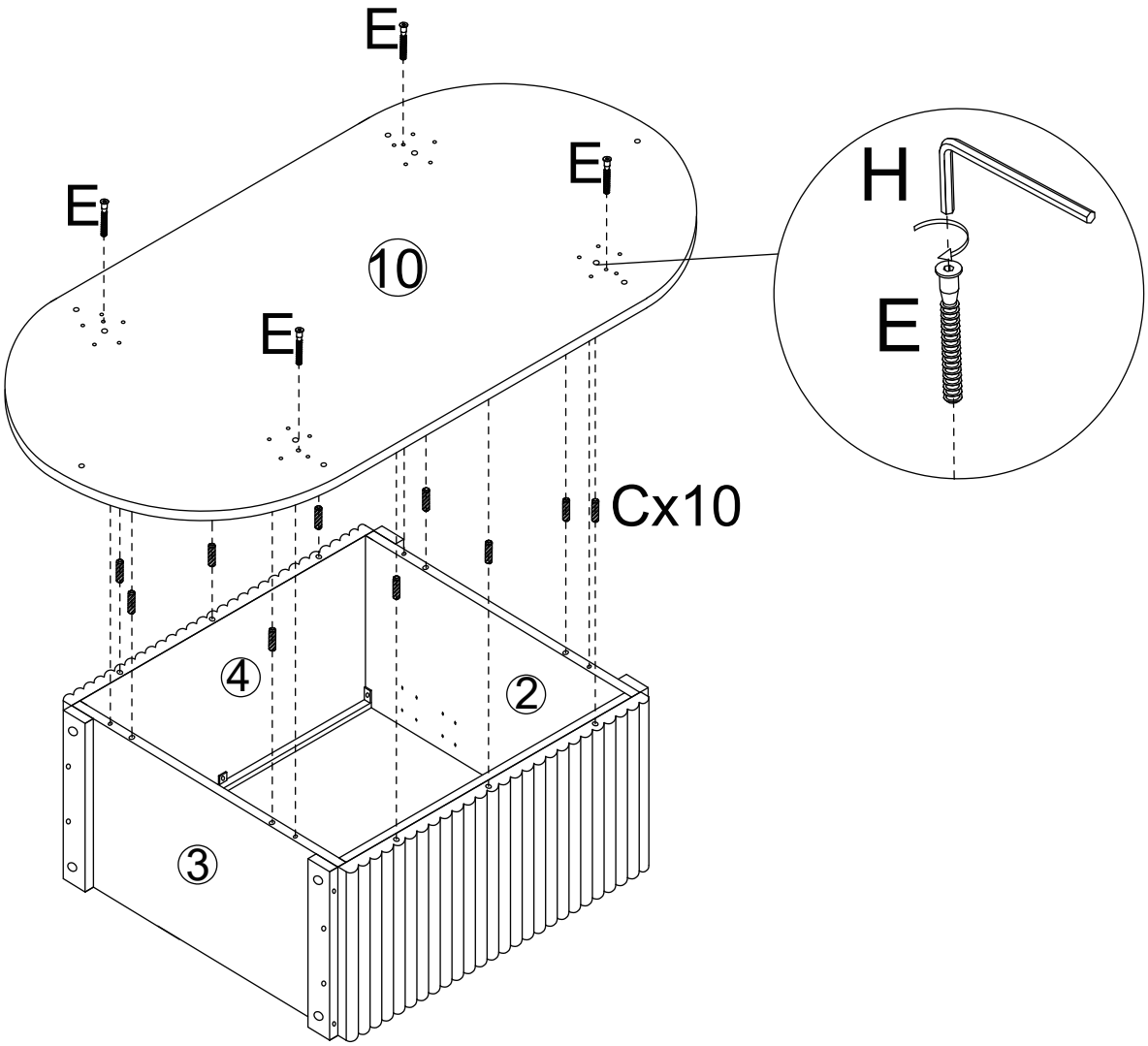

INSTALLATION STEPS

STEP 6

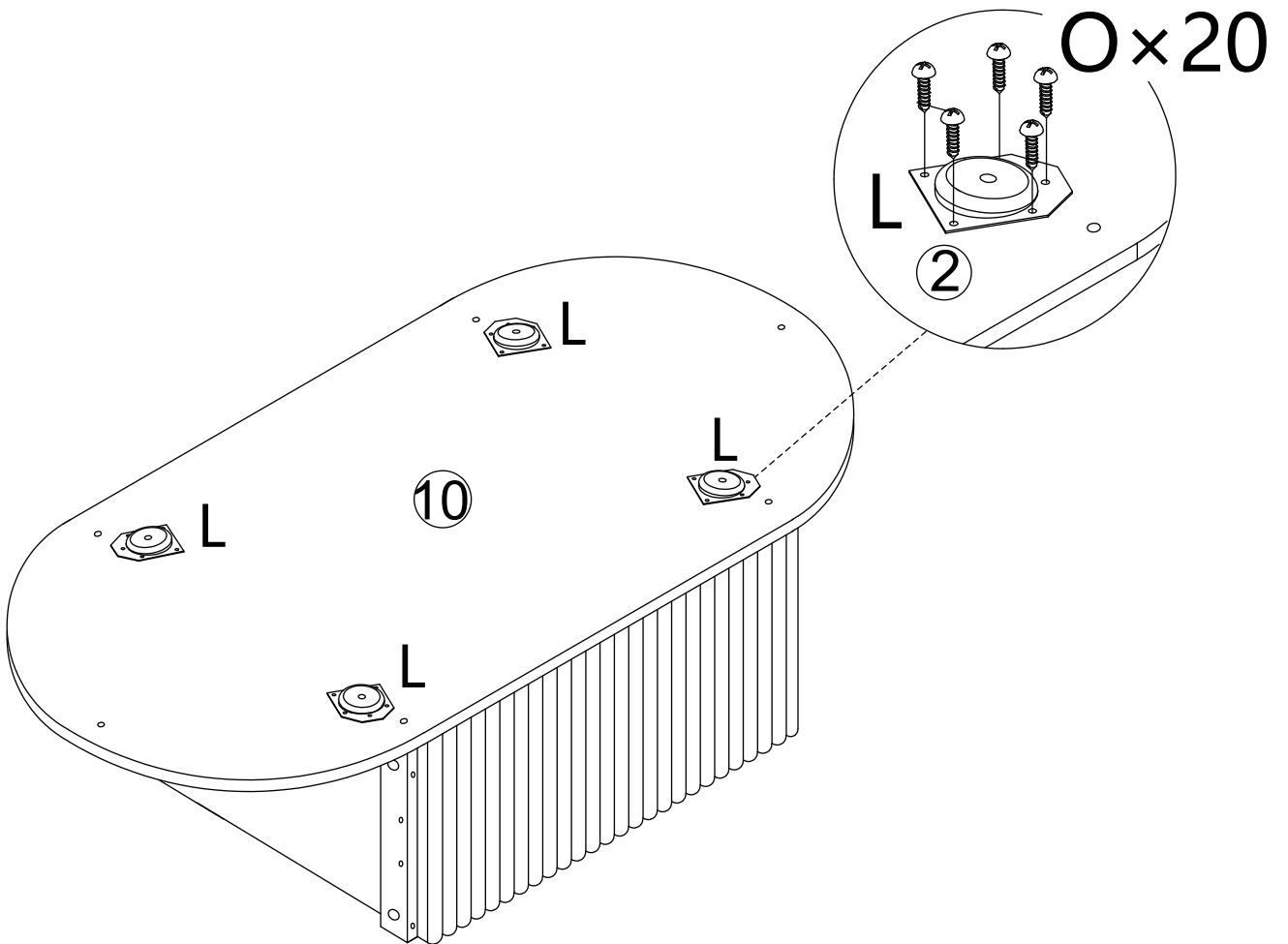
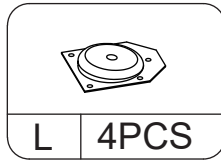
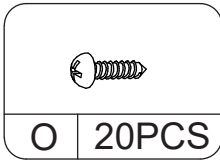

INSTALLATION STEPS

STEP 7

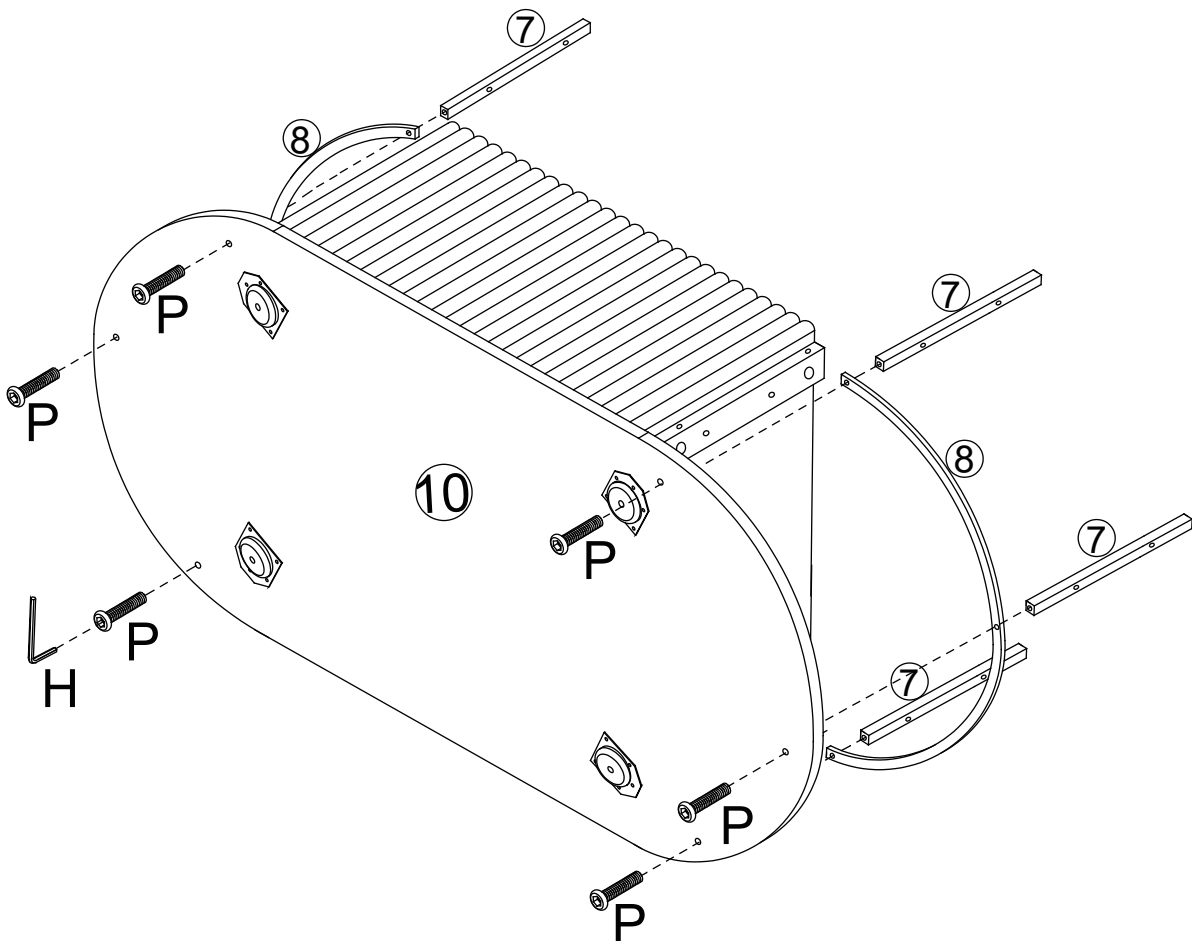
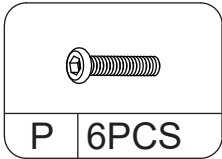

INSTALLATION STEPS

STEP 8

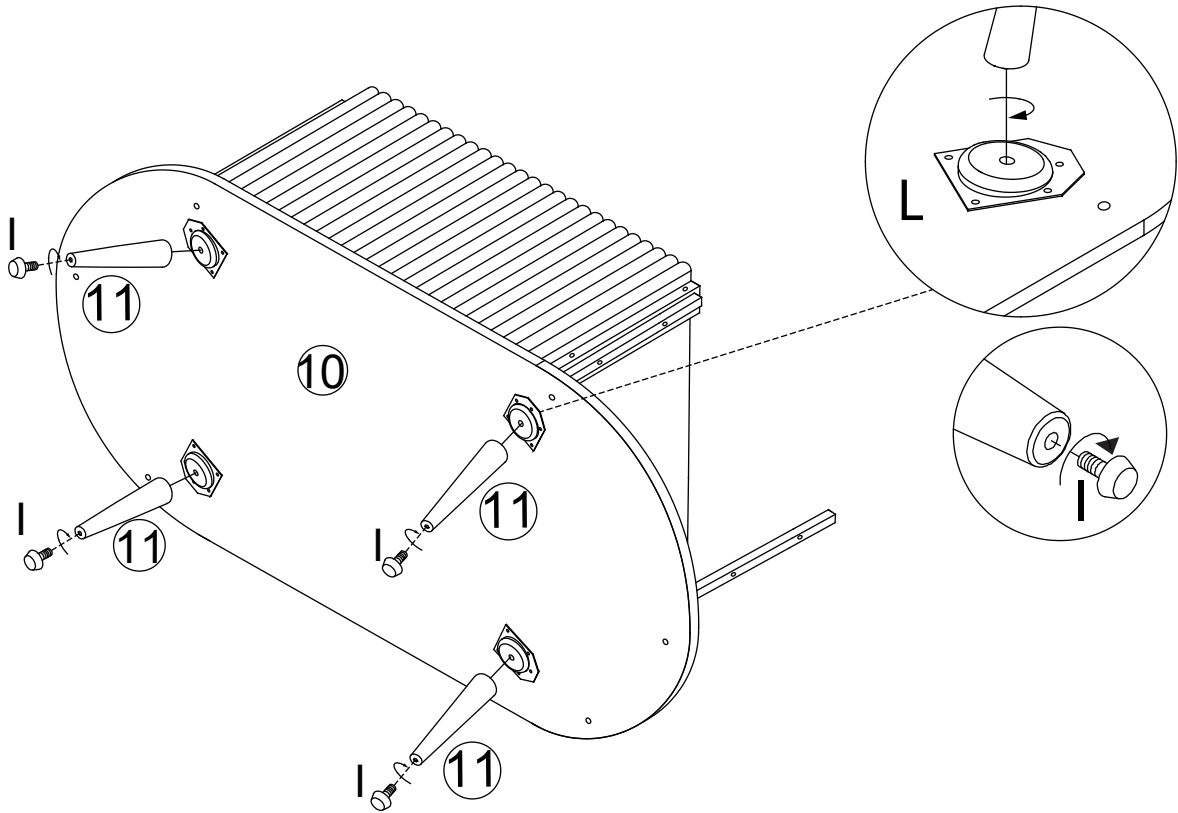
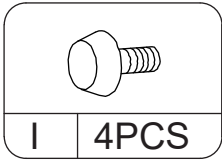

INSTALLATION STEPS

STEP 9

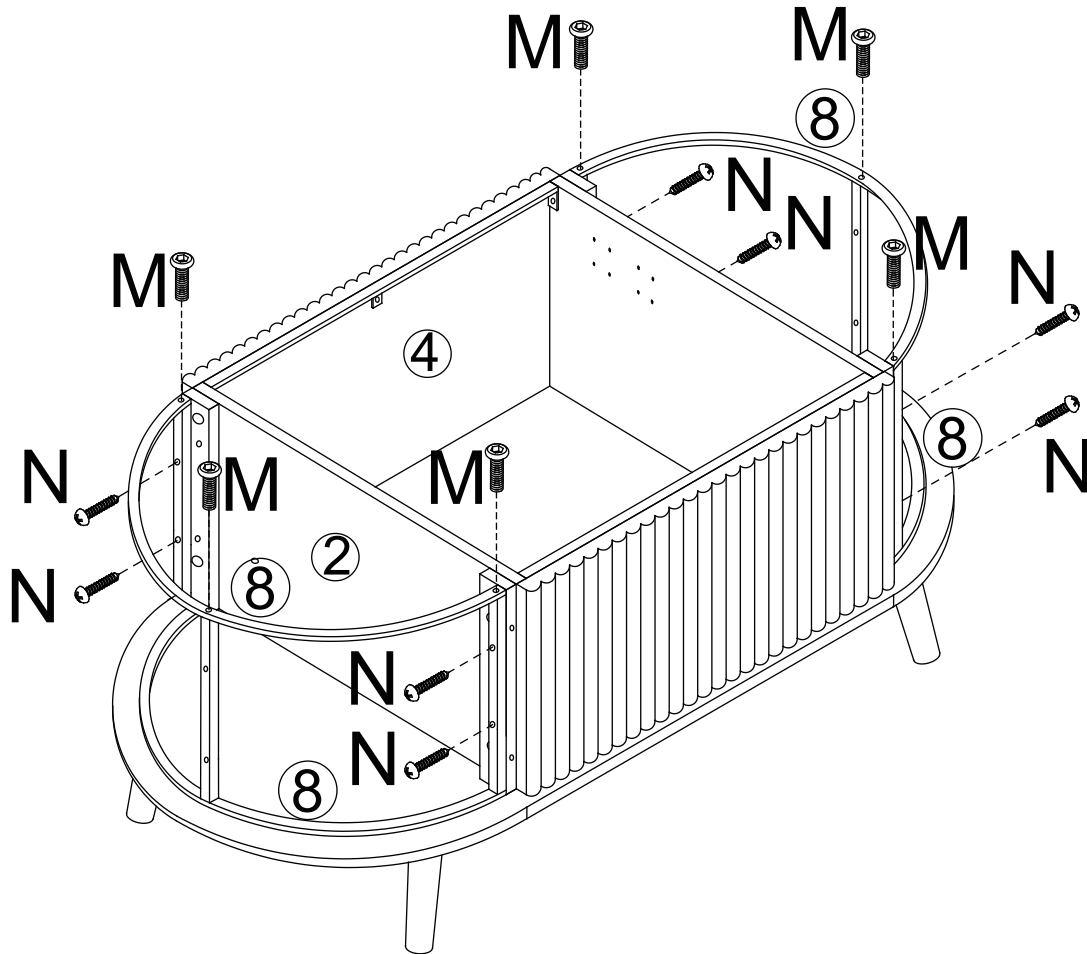
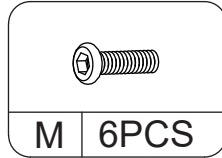
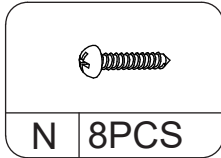

INSTALLATION STEPS

STEP 10

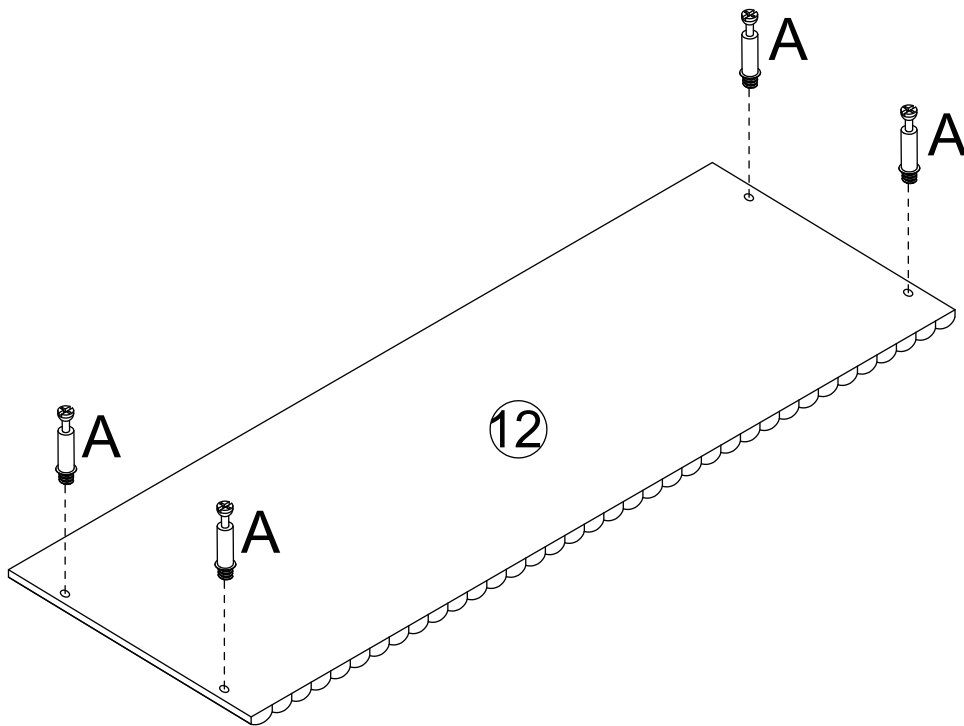
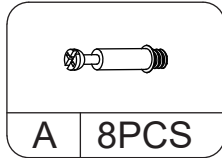

X2

INSTALLATION STEPS

STEP 11

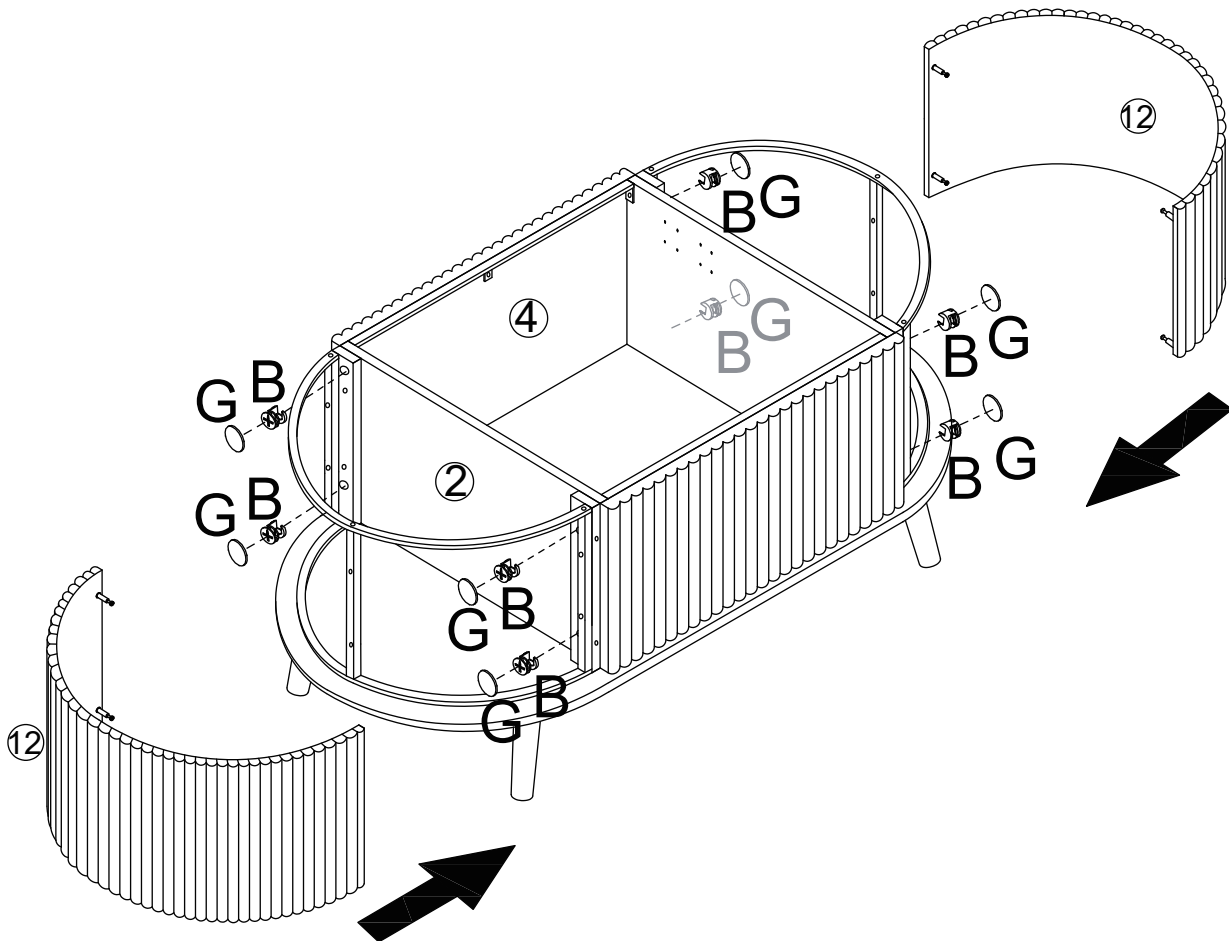
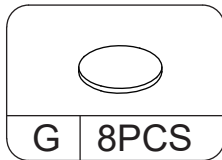
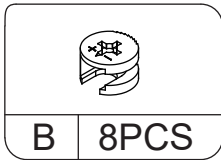

INSTALLATION STEPS

STEP 12

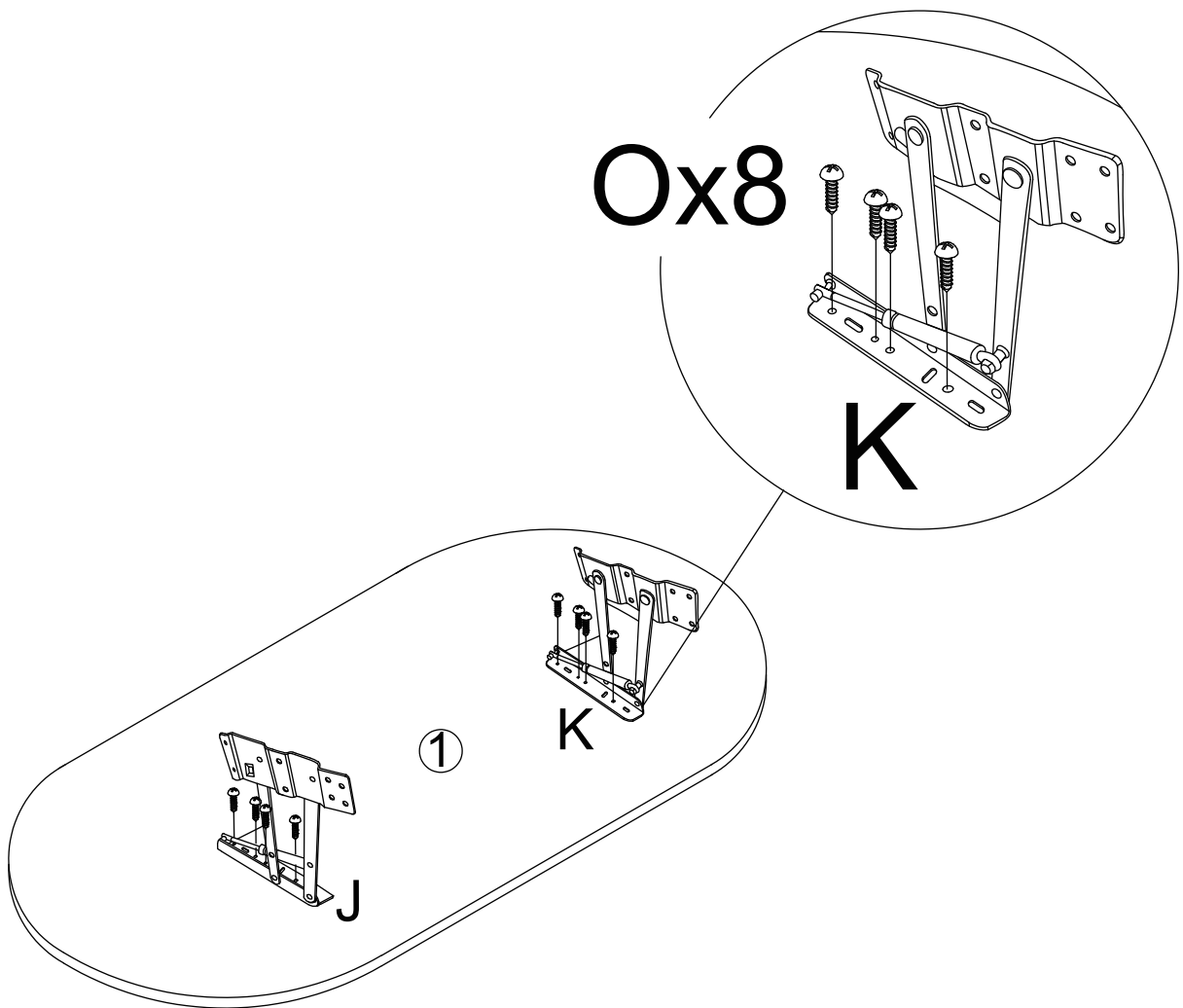
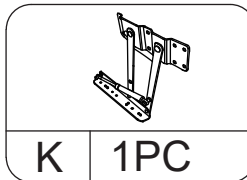
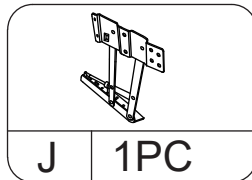
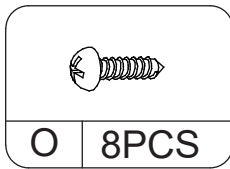

INSTALLATION STEPS

STEP 13

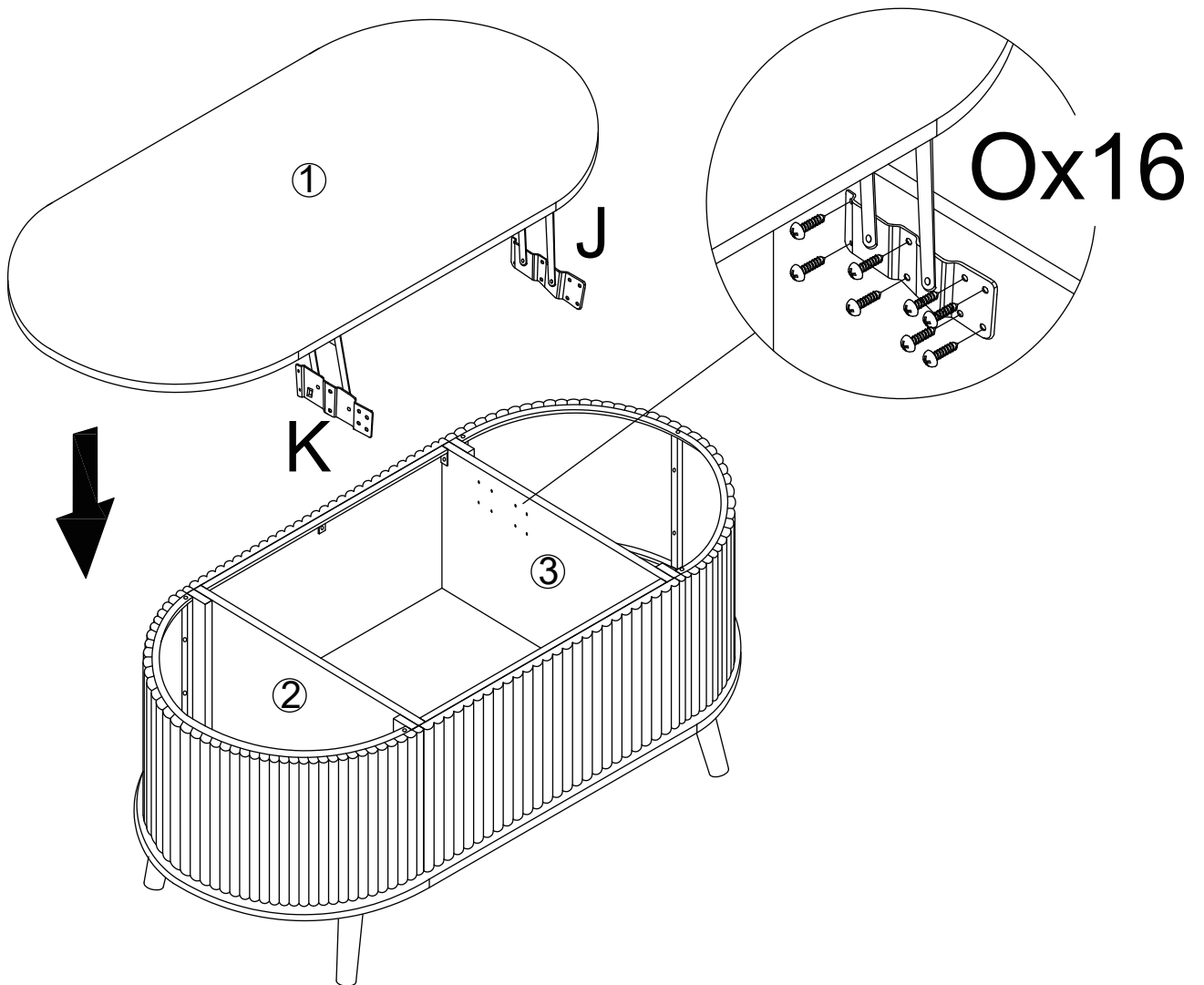
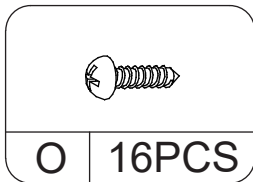

INSTALLATION STEPS

STEP 14

Attention!
For your safety, do not put anything on the top during lifting.

