

---

# Installation & Assembly

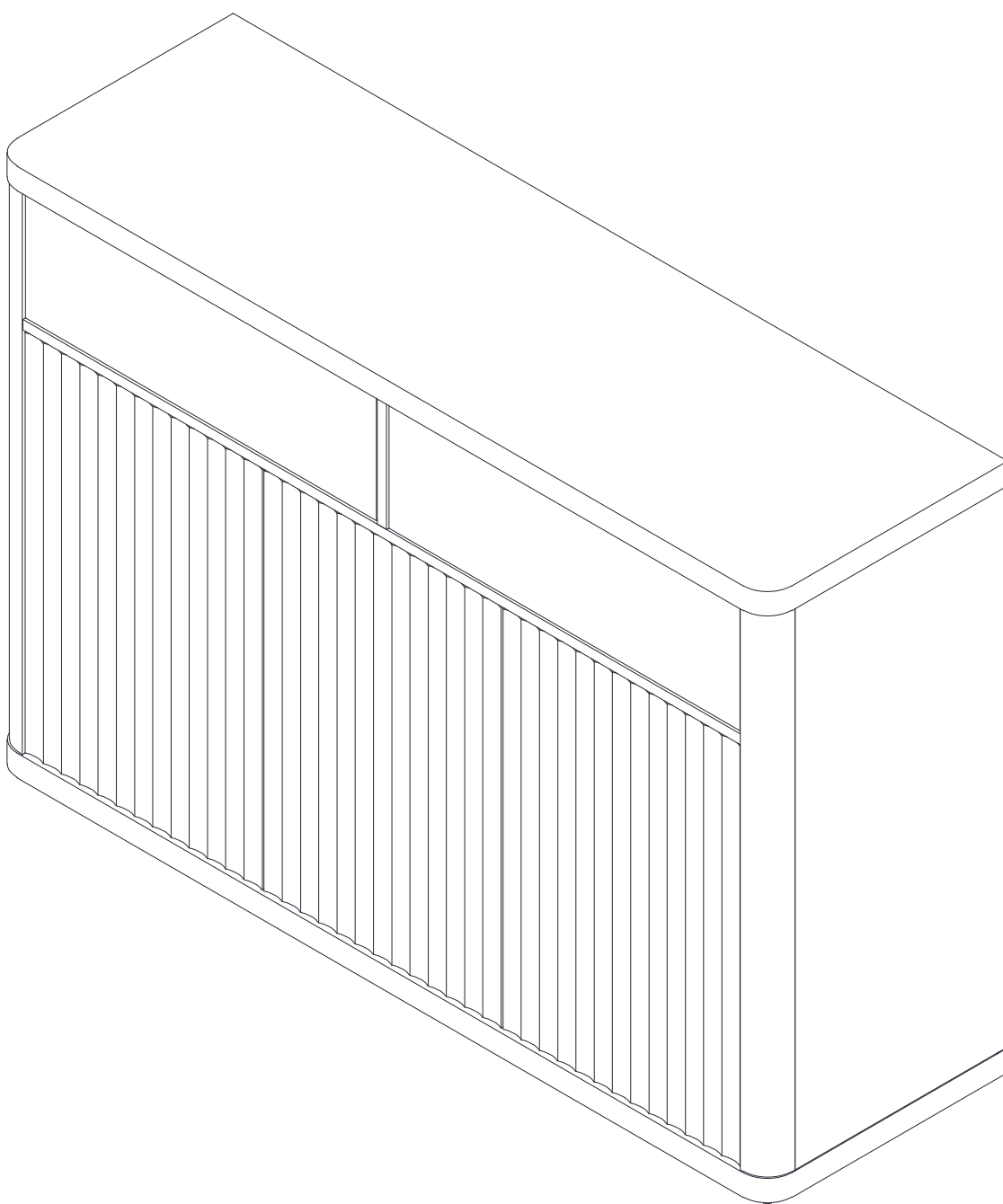

# Assembly Instructions

Before beginning the assembly process, please read and save these instructions for reference. Following these guidelines will ensure a smooth and successful assembly of your product.

## 1. Part Identification:

Carefully separate and identify all the parts included in your package. Confirm that you have all the components listed in the instruction manual. This step will help you avoid any missing or misplaced parts during assembly.

## 2. Work Surface:

To prevent any scratches or damage to the product, assemble it on a soft mat or a similar protective surface. This will provide a cushioned area for the components and protect the surfaces from unwanted marks.

## 3. Step-by-Step Assembly:

Follow the assembly instructions provided, proceeding one step at a time. Take care to understand each step properly before proceeding to the next one. This sequential approach ensures that the assembly is done correctly and minimizes the chance of errors.

## 4. Proper Screw Seating:

When attaching screws and nuts, it is essential not to fully tighten them until all screws are correctly seated. By partially tightening each screw and nut initially, you can ensure that they are aligned properly and fit securely before final tightening.

## 5. Avoid Over-Tightening:

While each screw and nut should be tightened correctly, it is crucial not to over-tighten them. Over-tightening can cause damage to the product or compromise its structural integrity. Use the appropriate amount of force to secure the components without excessive tightening.

If you encounter any questions or problems during the assembly process, please do not hesitate to contact us. We strive to provide excellent customer support and will respond to your inquiries within 24 hours. Our team will offer you a suitable solution to address any concerns you may have.



# Step 1

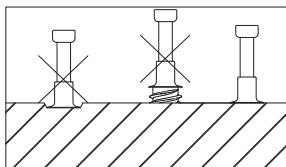
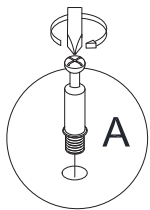
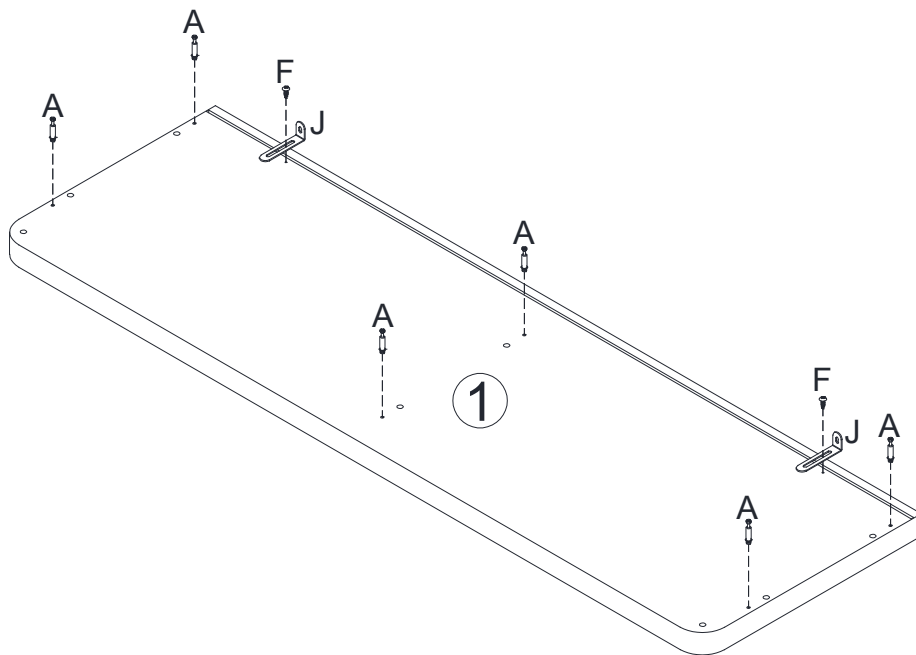

F  X 2

J  X 2

A  X 6

# Step 2

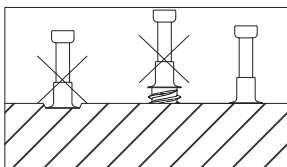
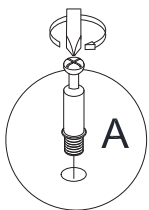
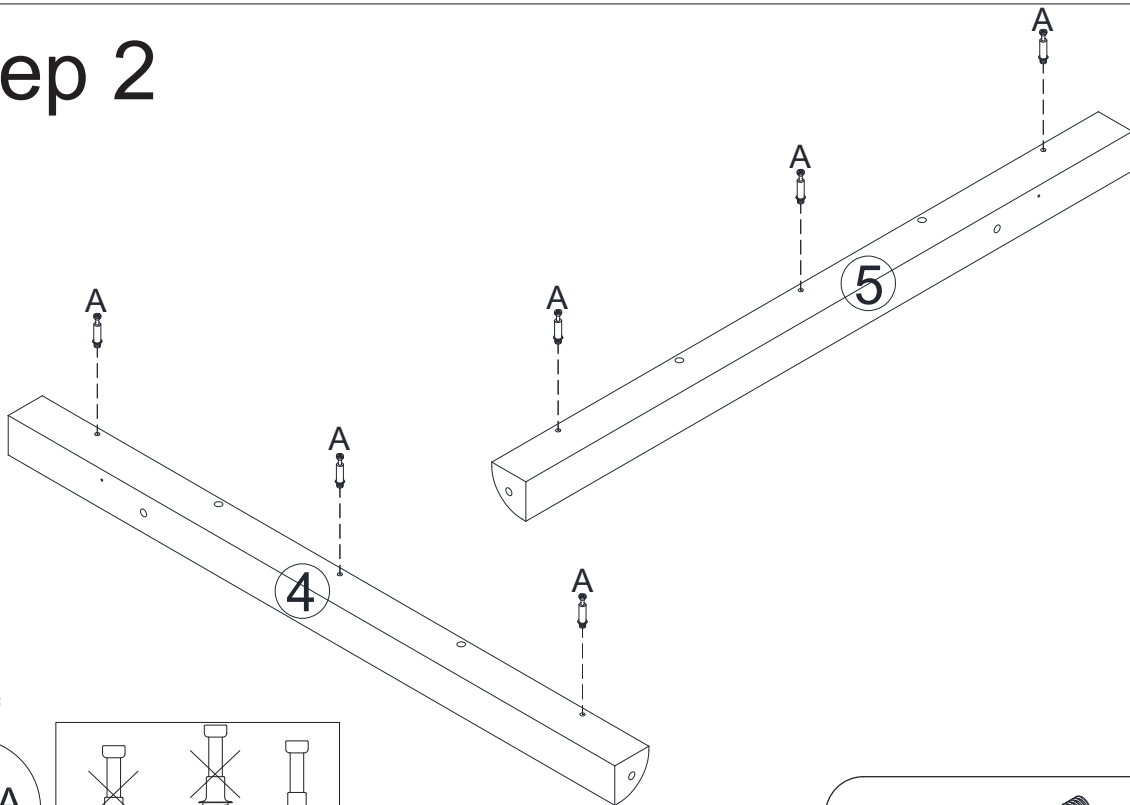

A  X 6

# Step 3

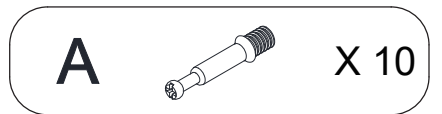
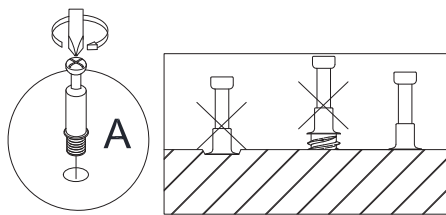
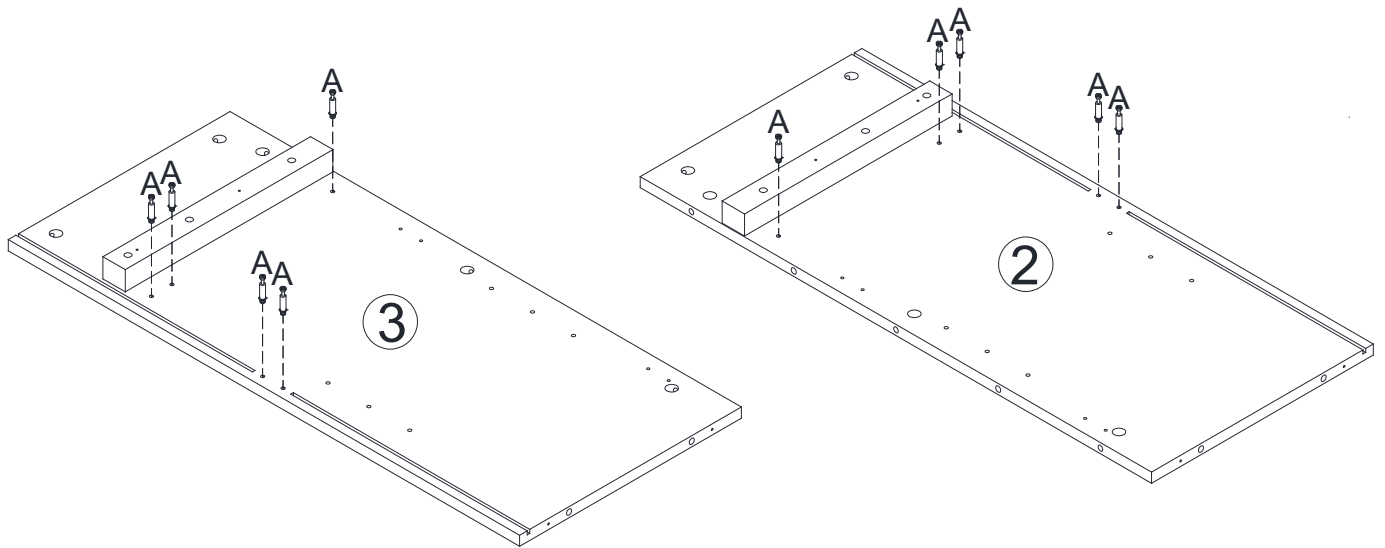

# Step 4

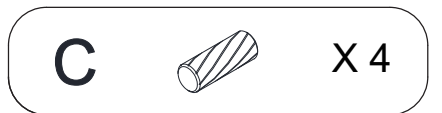
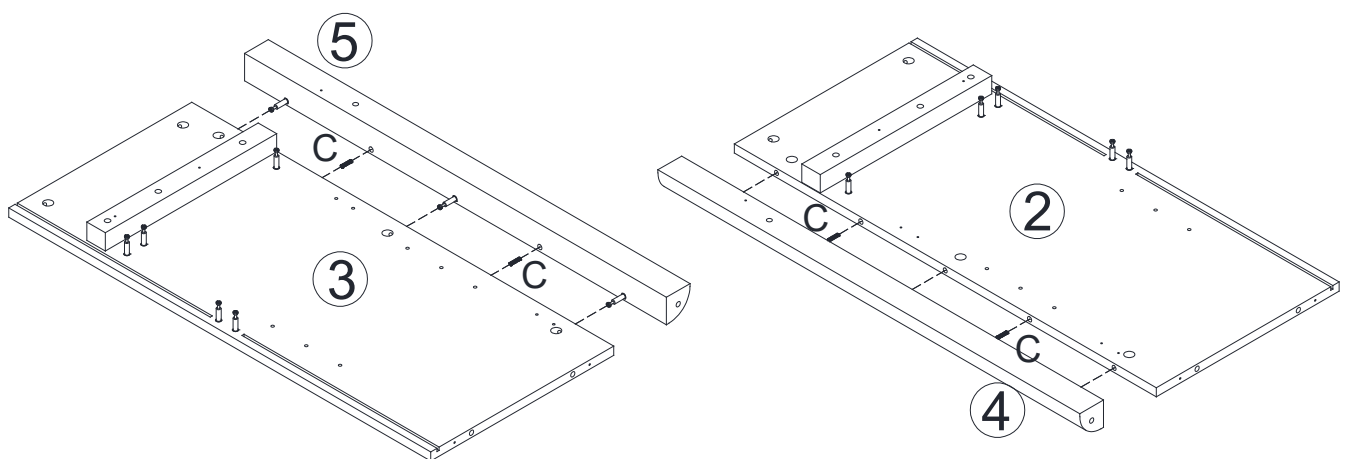

# Step 5

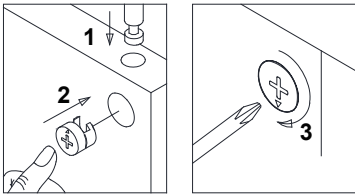
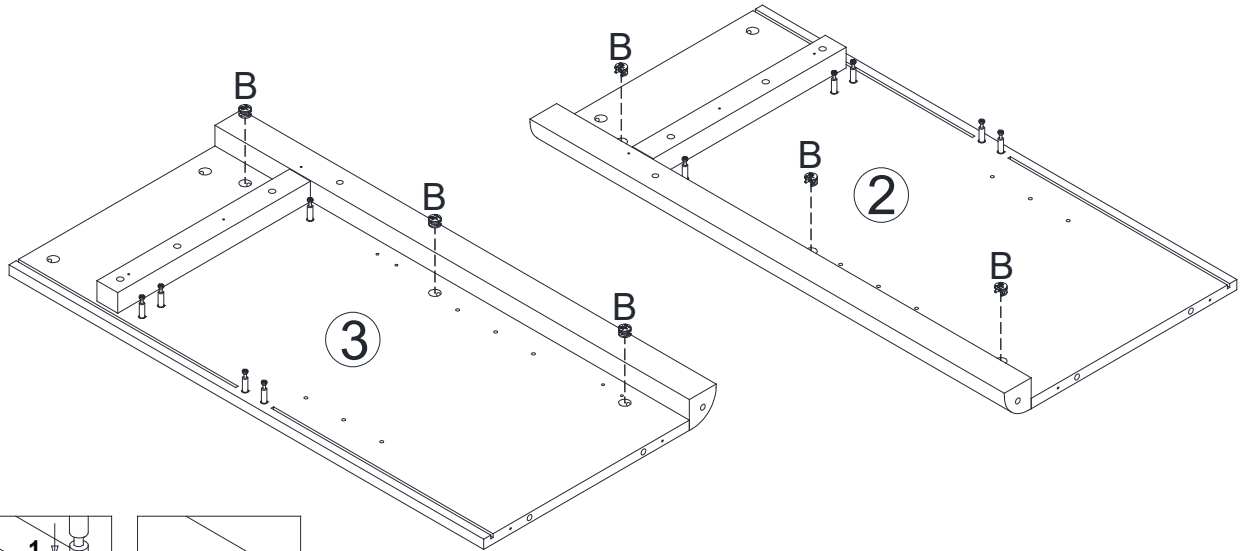

**B**



**X 6**

# Step 6

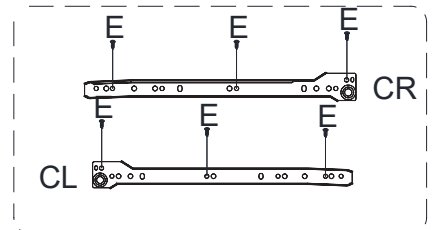
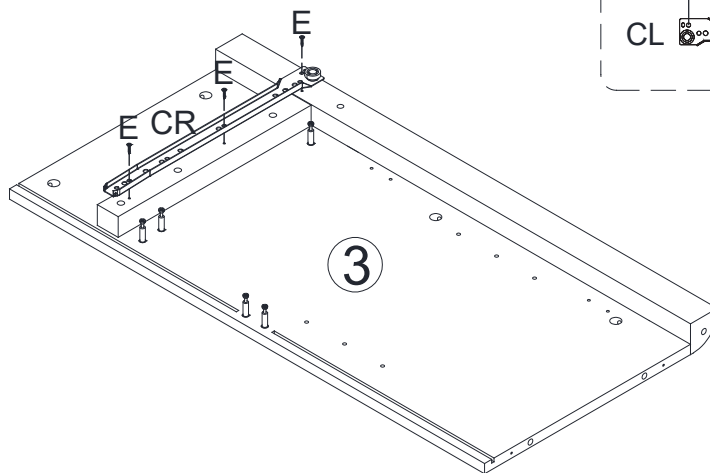

**E**



**X 3**



**CR**



**X 1**

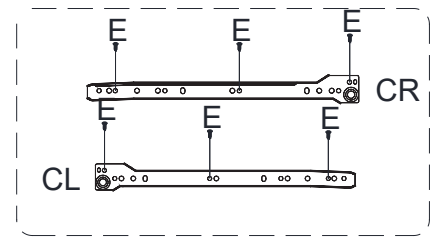
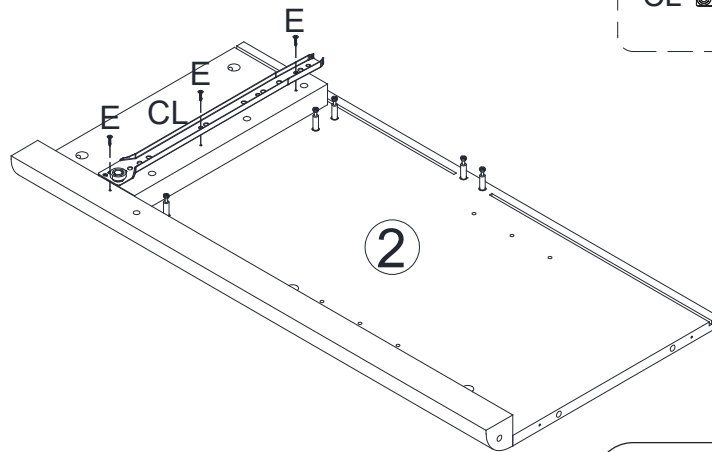

# Step 7

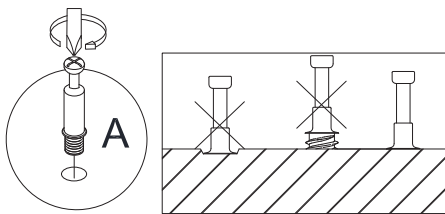
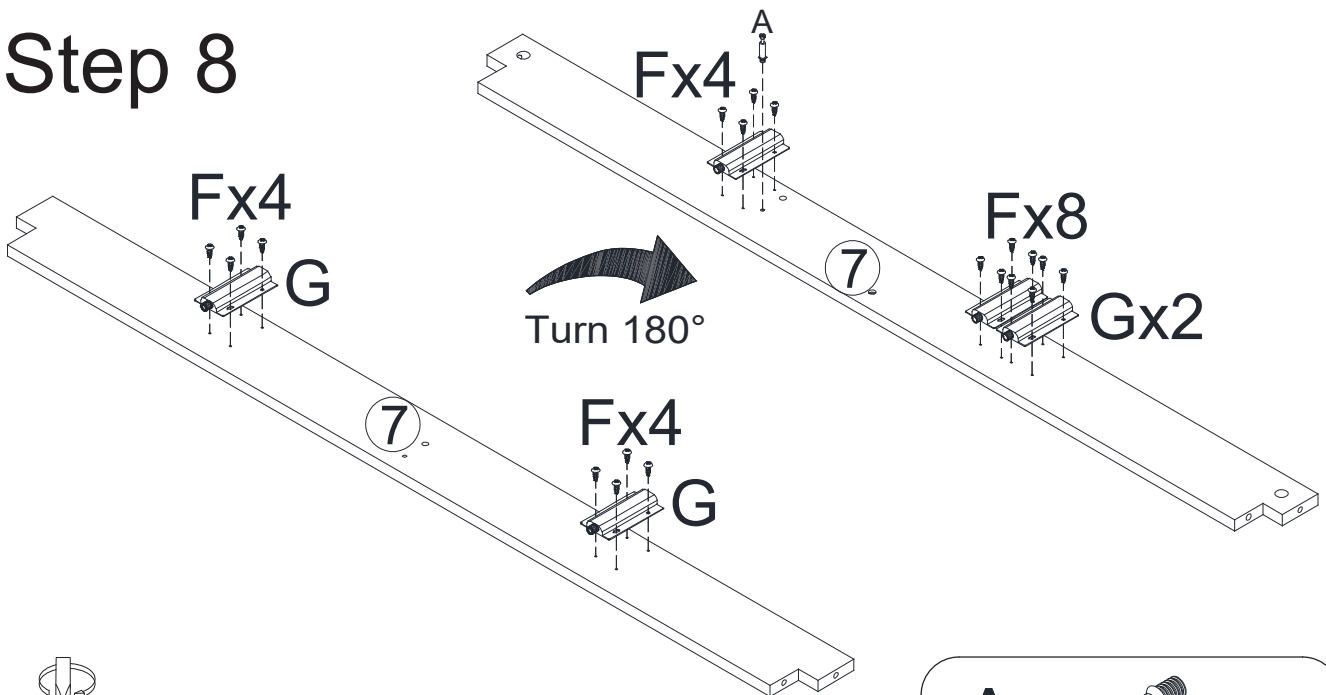

- E**  X 3
- CL**  X 1

# Step 8



- A**  X 1
- F**  X 20
- G**  X 5

# Step 9

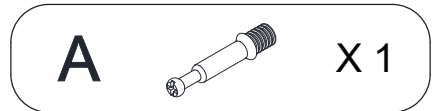
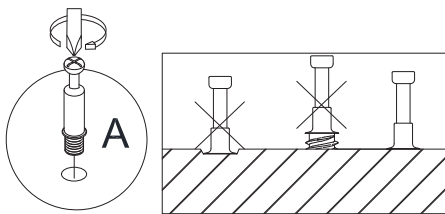
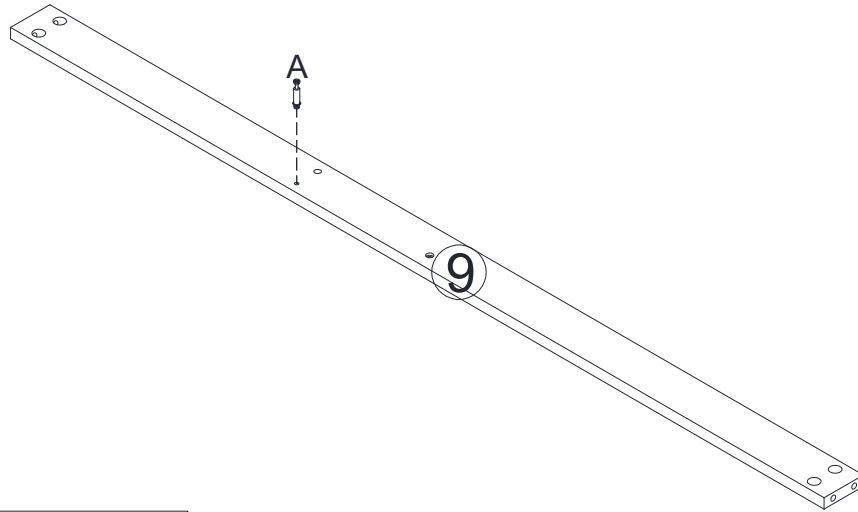

# Step 10

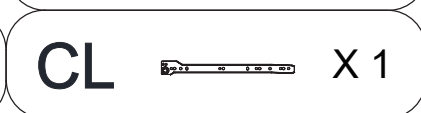
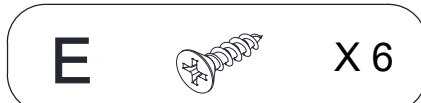
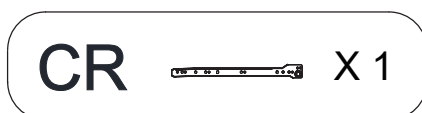
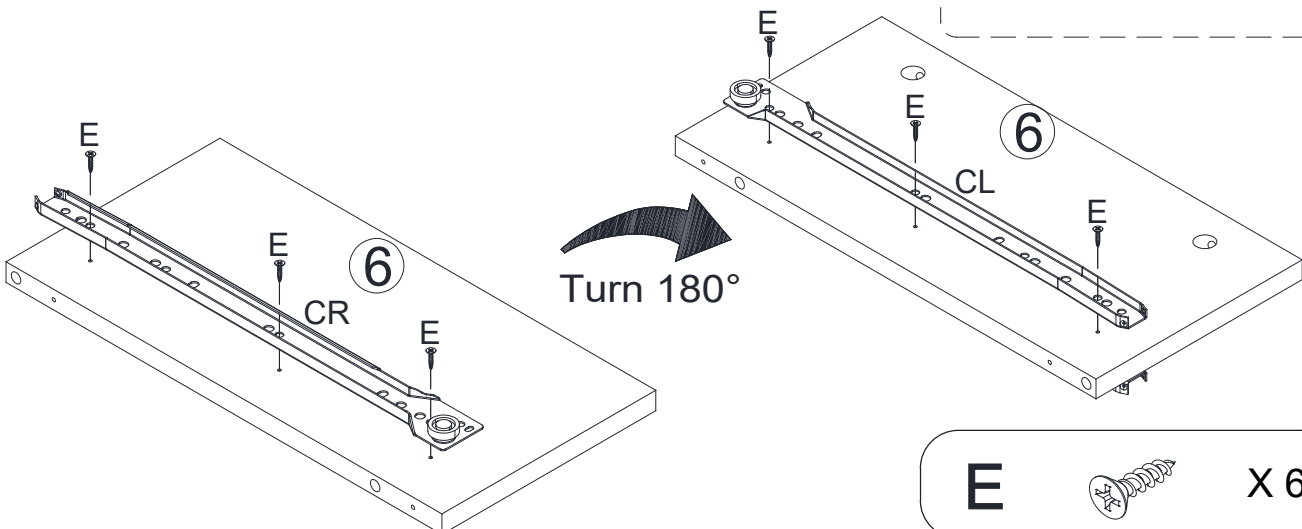
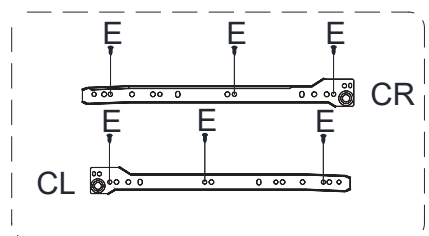

# Step 11

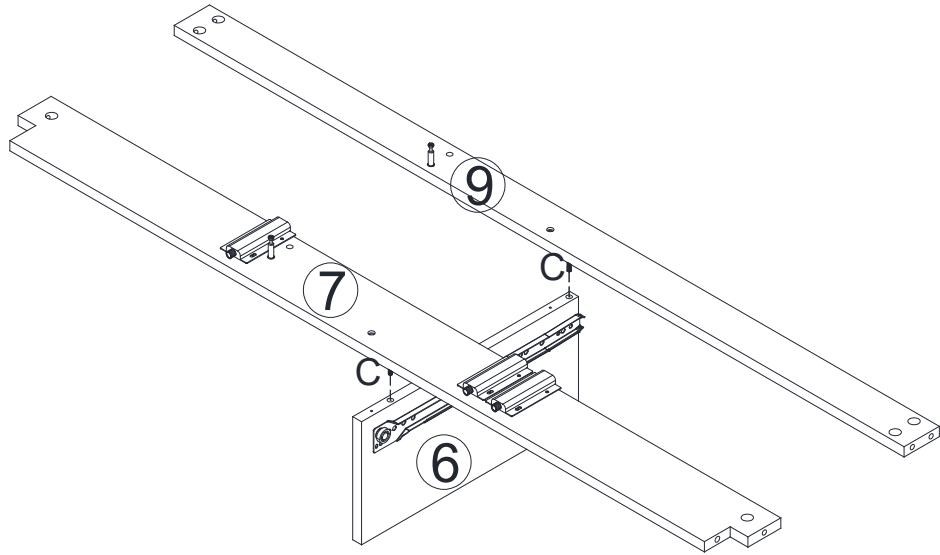

C



X 2

# Step 12

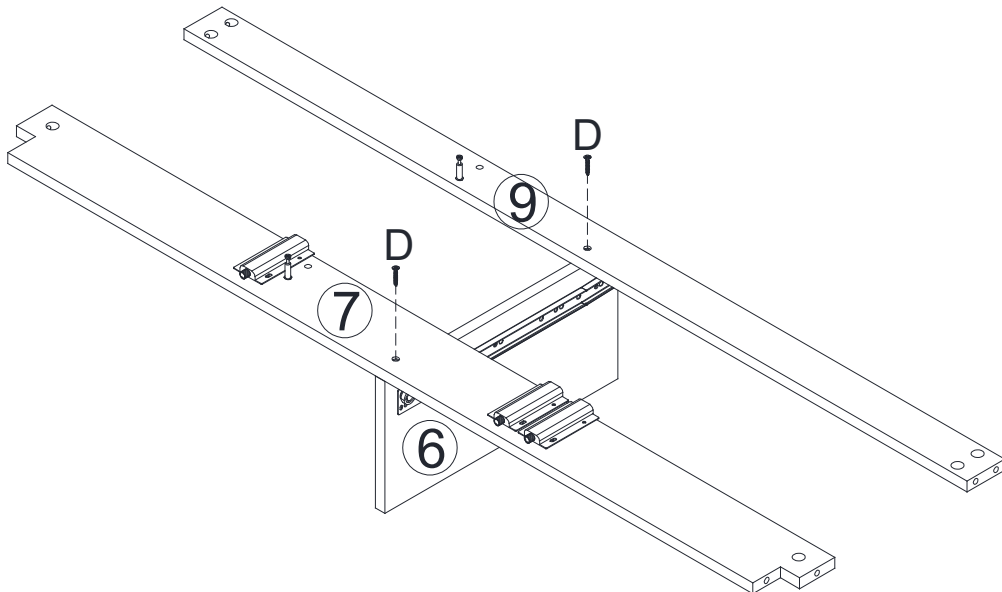

D



X 2

# Step 13

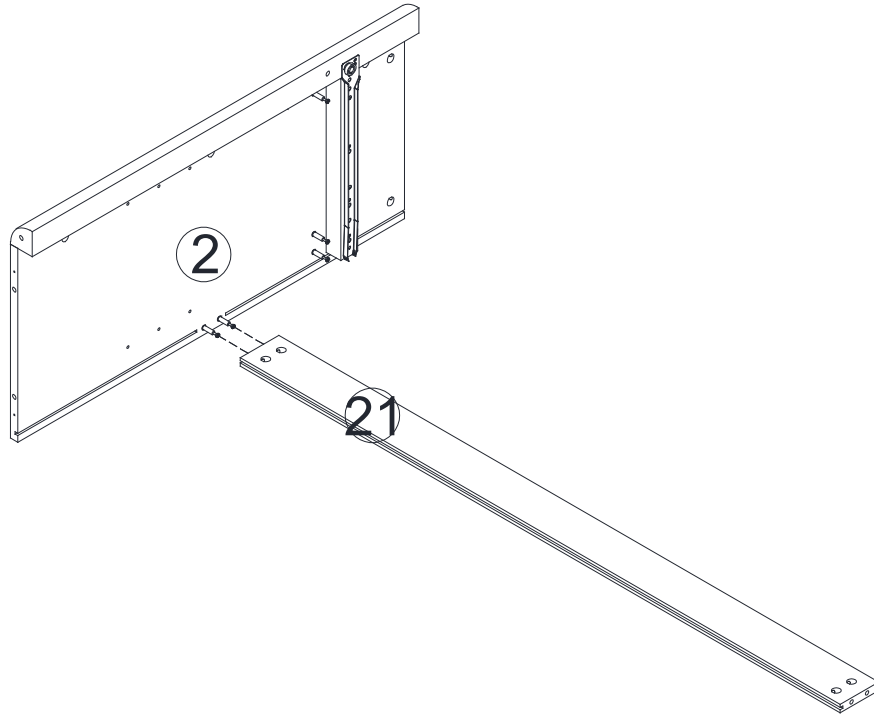

# Step 14

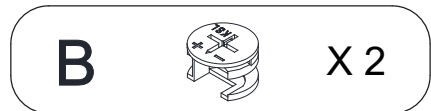
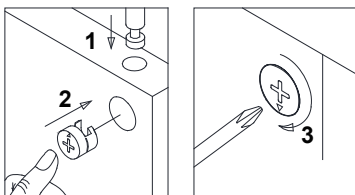
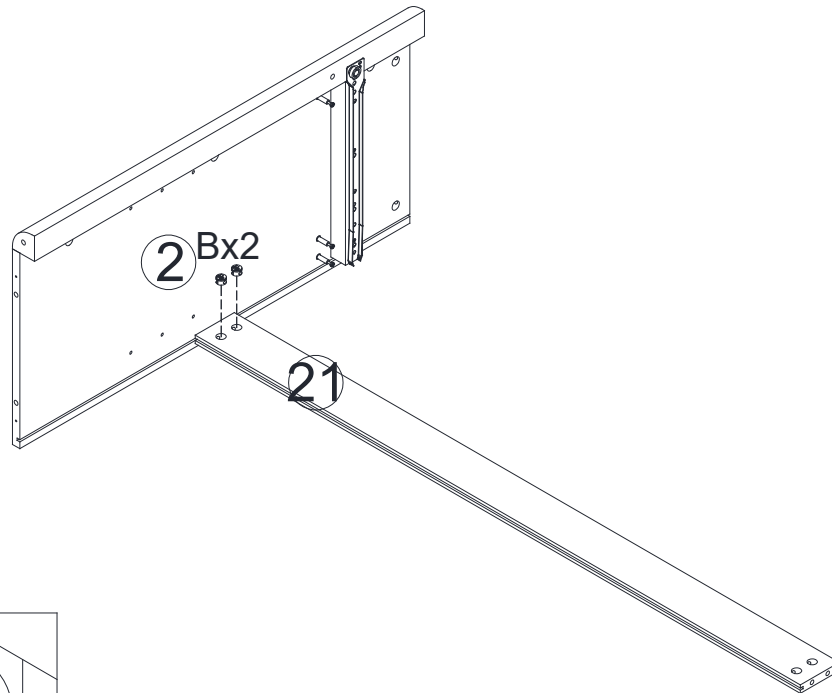

# Step 15

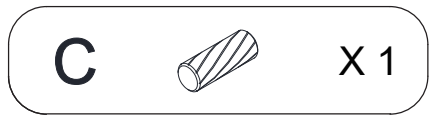
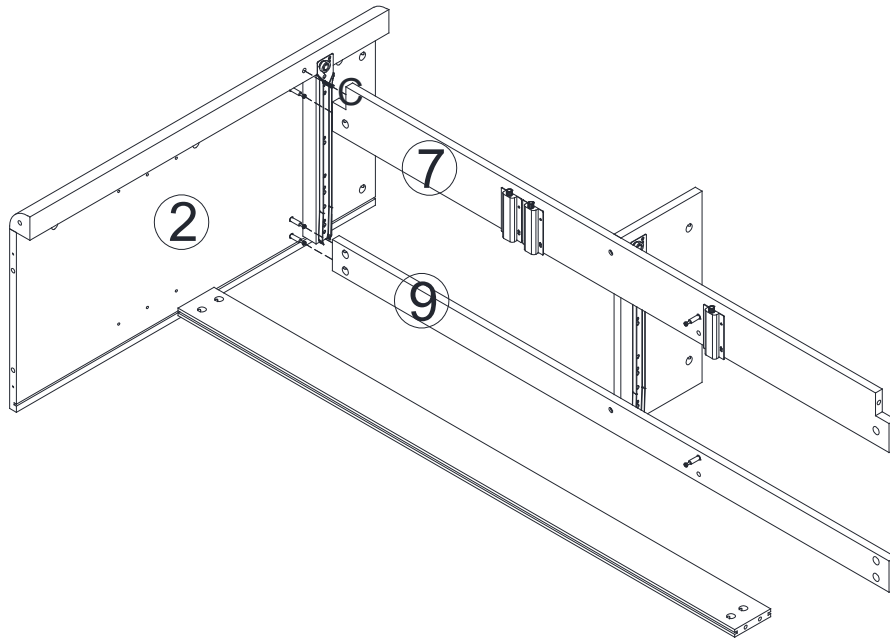

# Step 16

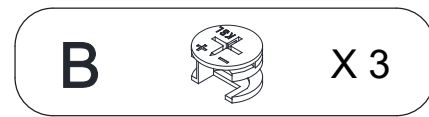
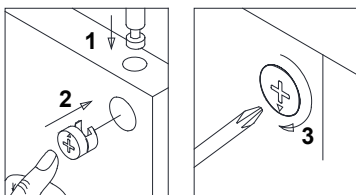
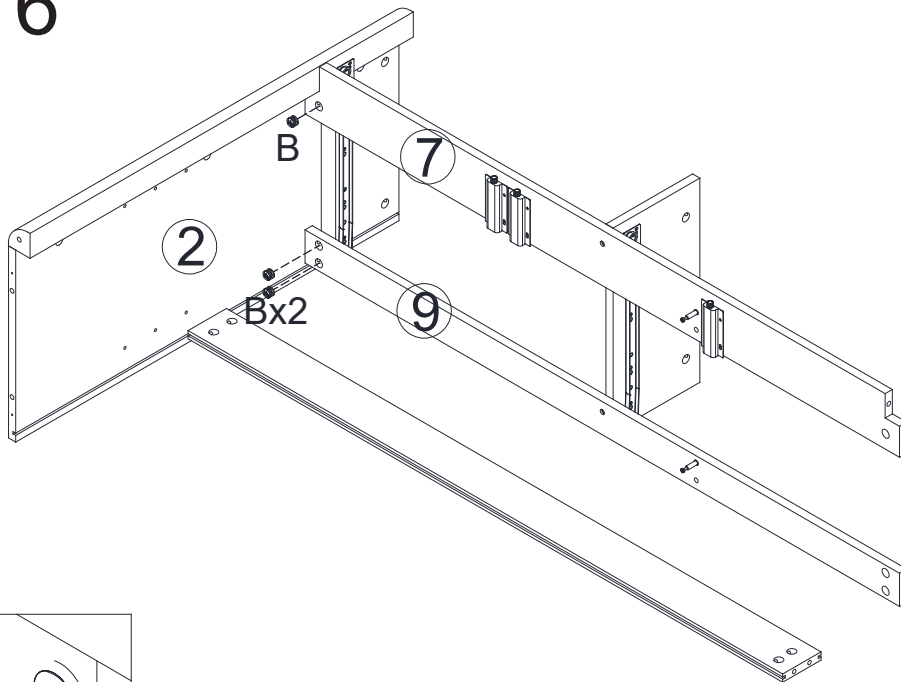

# Step 17

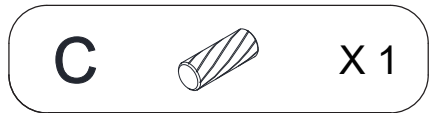
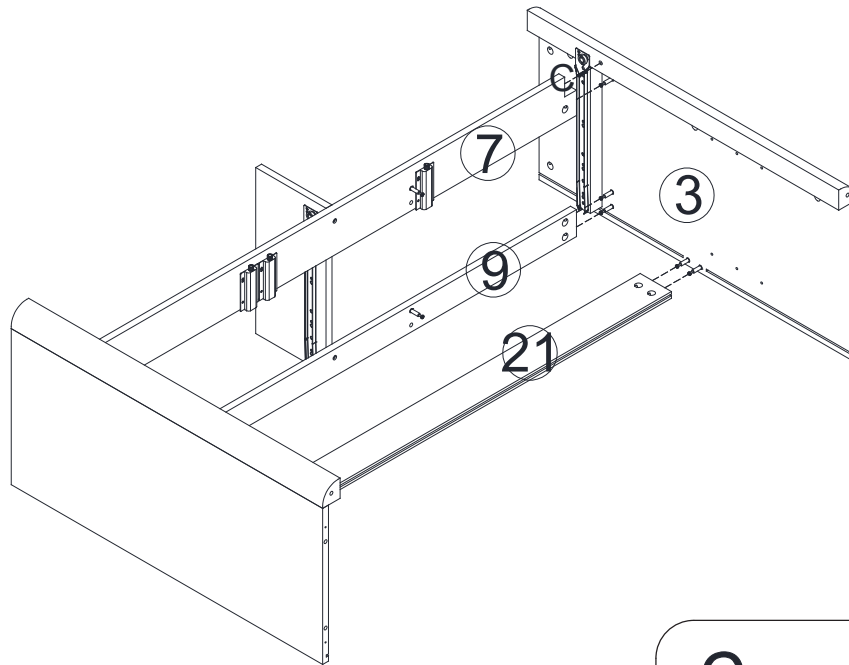

# Step 18

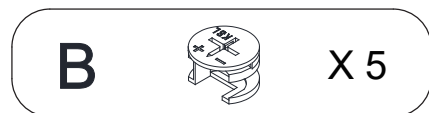
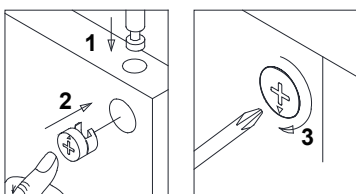
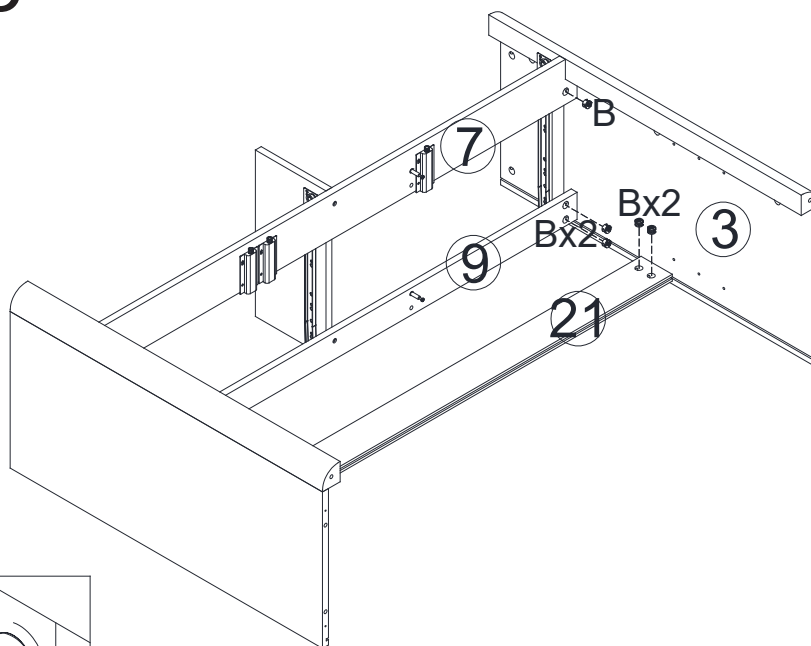

## Step 19

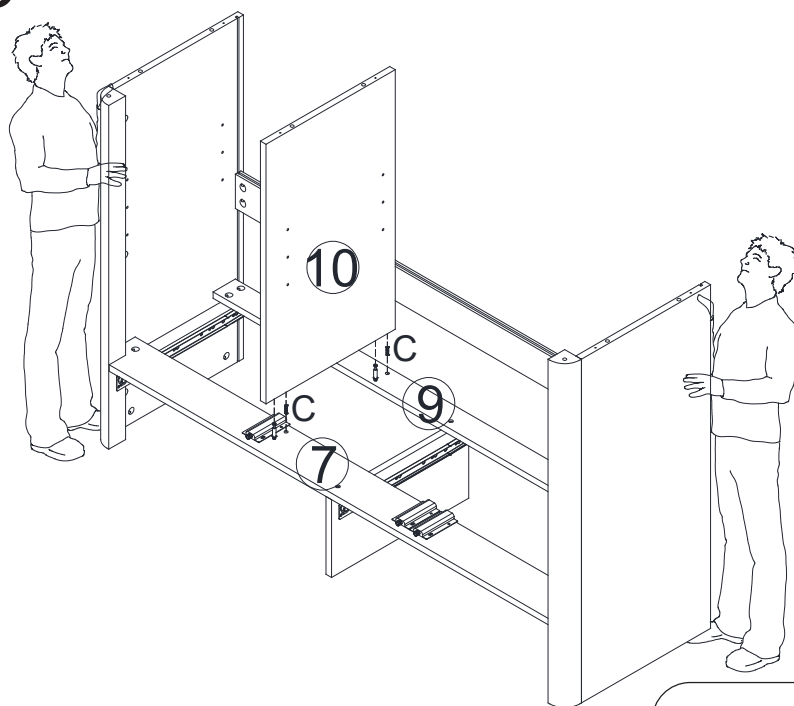

C



X 2

## Step 20

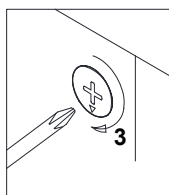
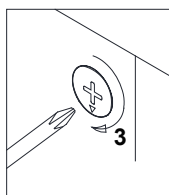
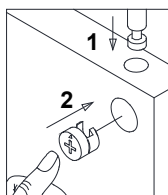
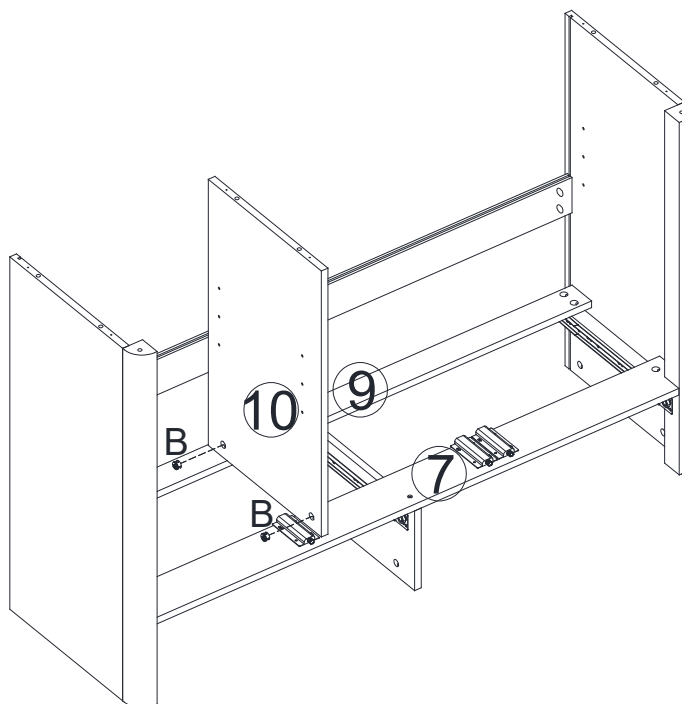

B



X 2

## Step 21

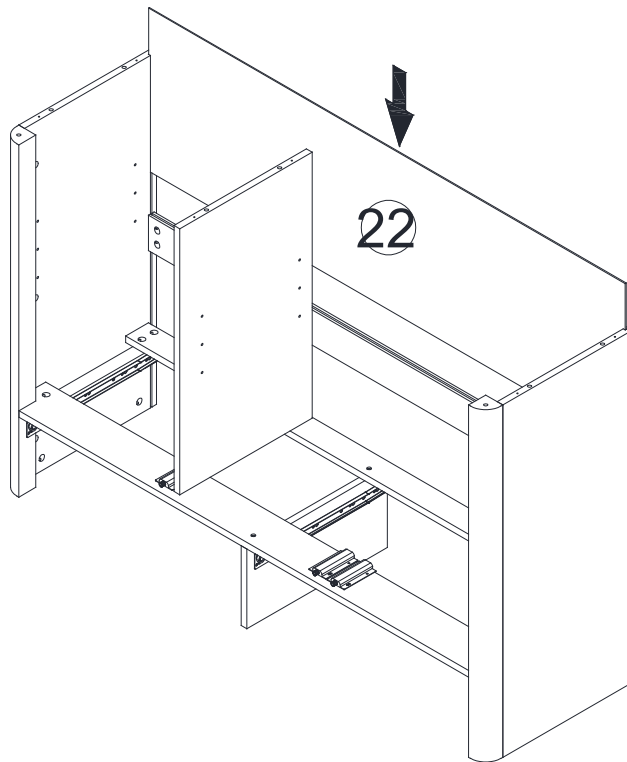

## Step 22

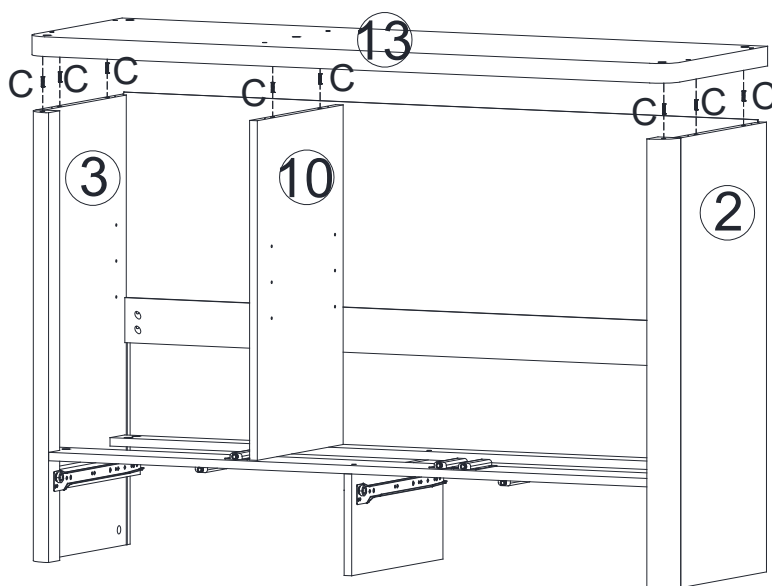

C



X 8

## Step 23

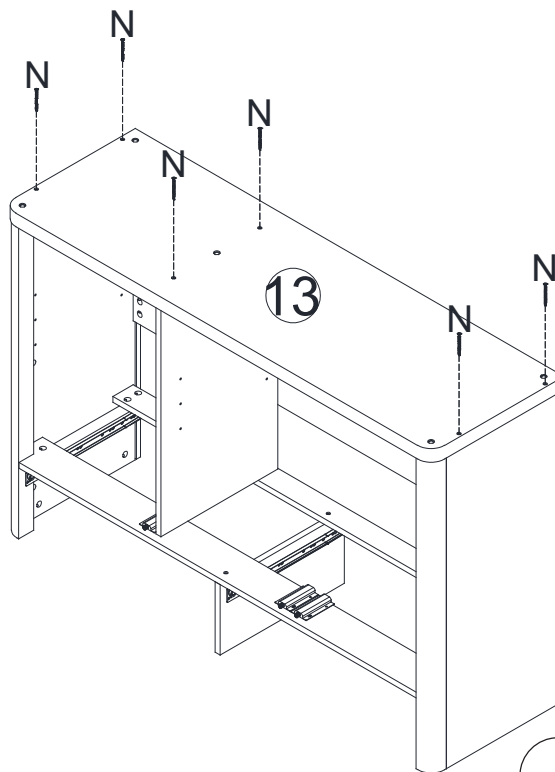

N



X 6

## Step 24

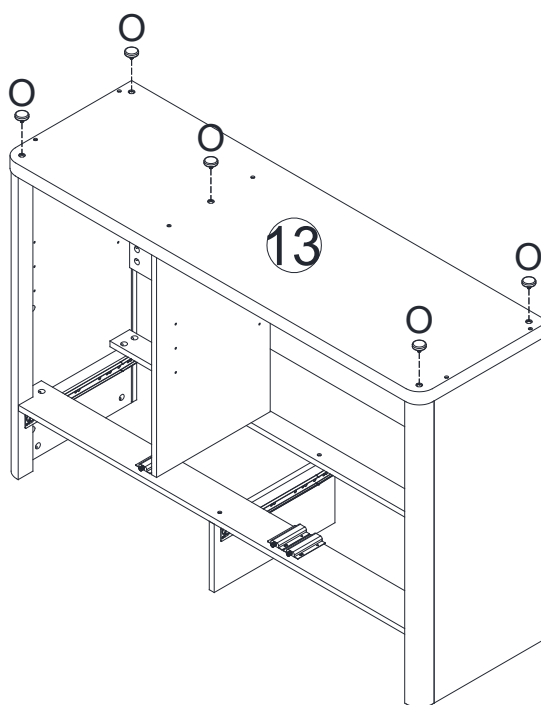

O



X 5

## Step 25

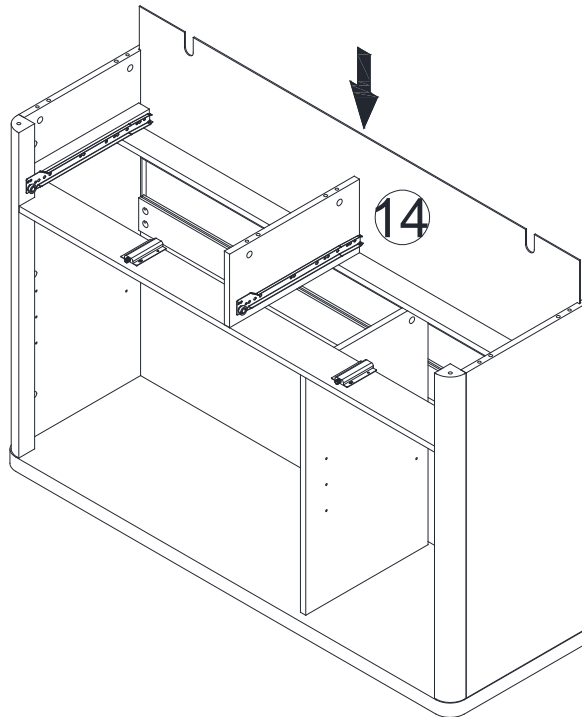

## Step 26

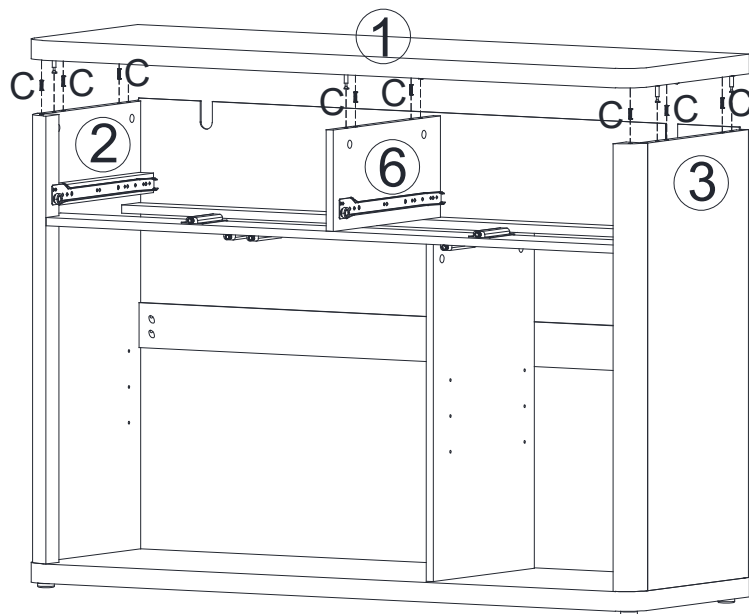



C

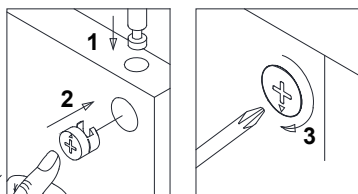
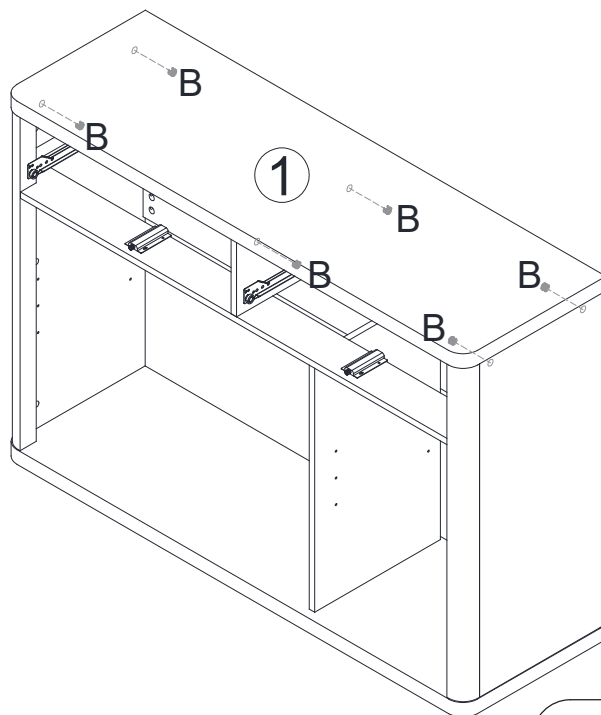

X 8

# Step 27





**B**  **X 6**

# Step 28

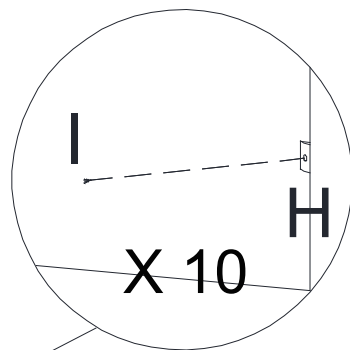
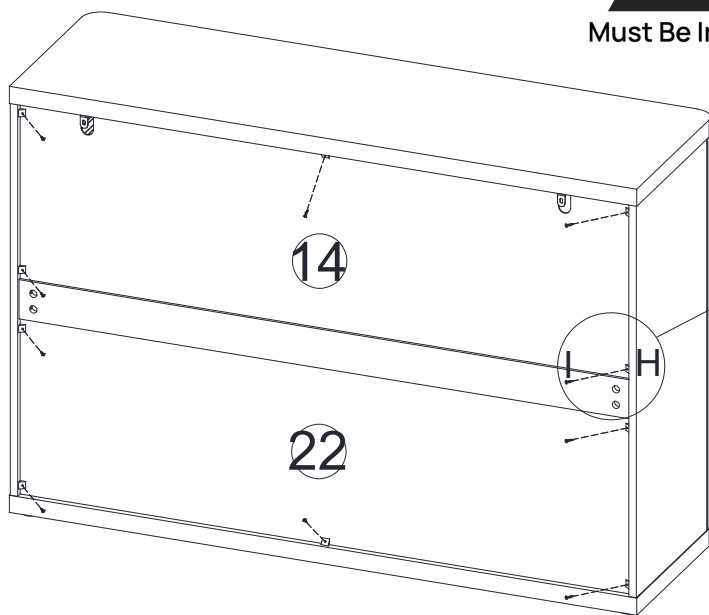
  
Must Be Installed



**I**  **X 10**

**H**  **X 10**

## Step 29

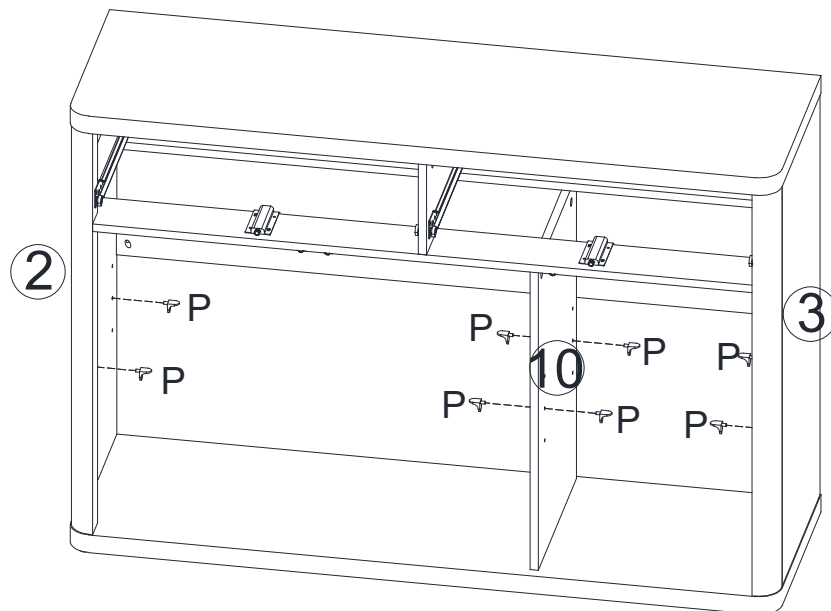

P



X 8

## Step 30

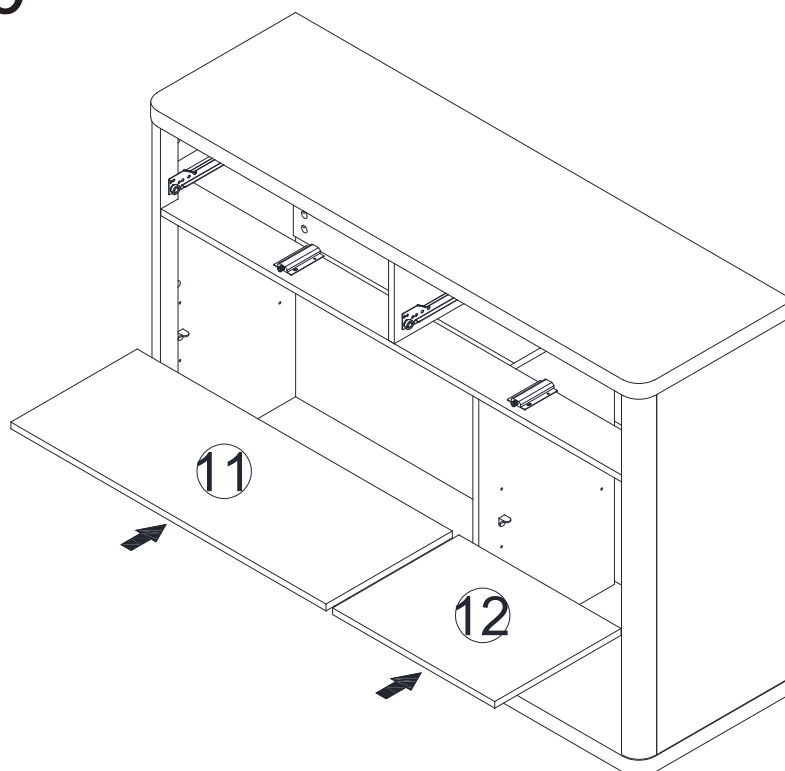

# Step 31

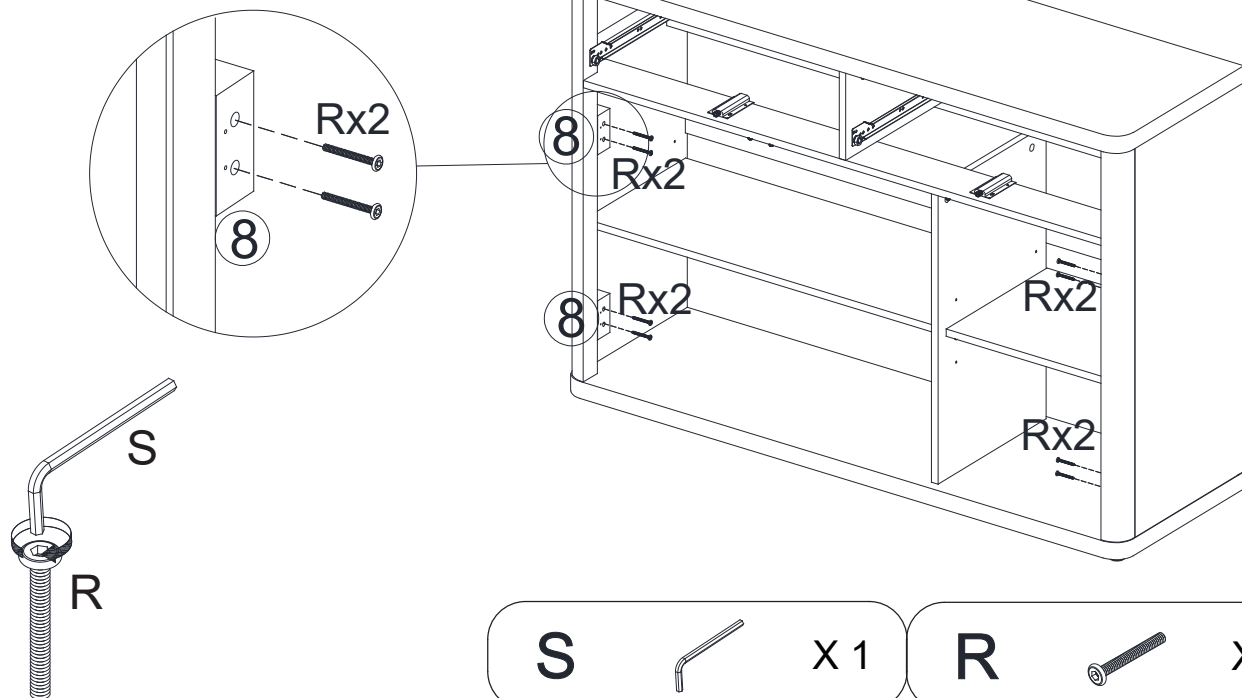

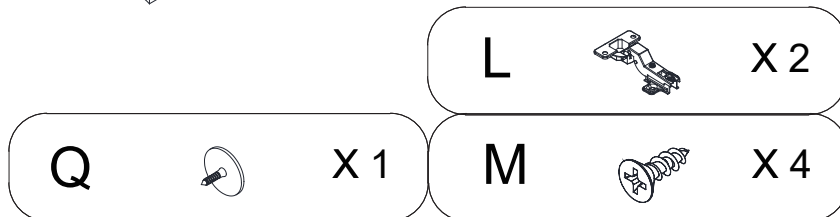
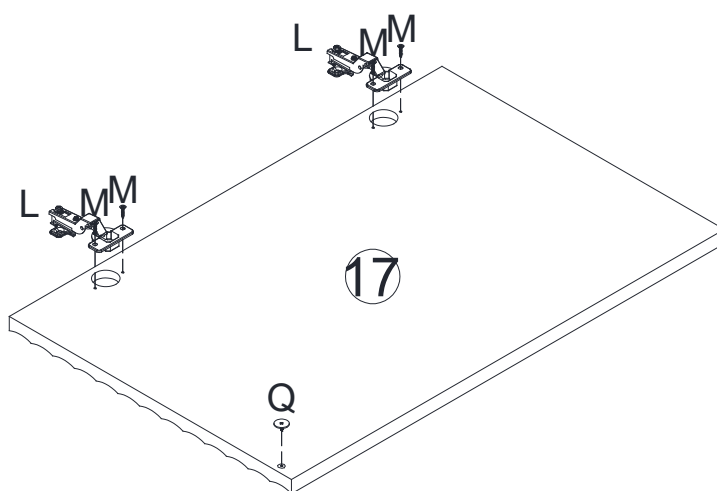

# Step 32



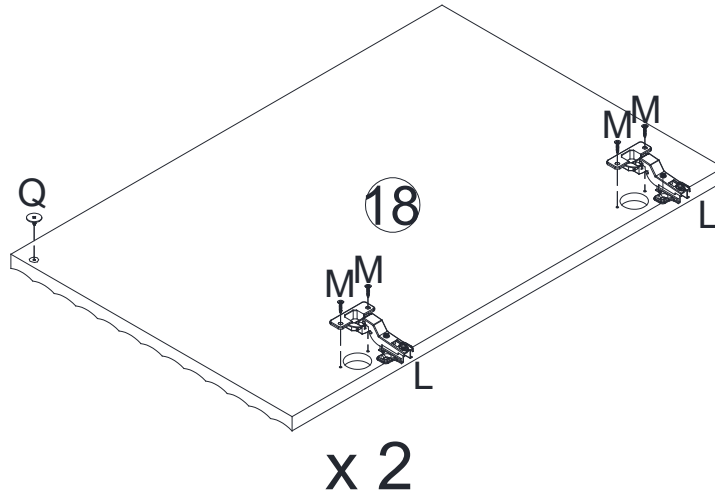

# Step 33

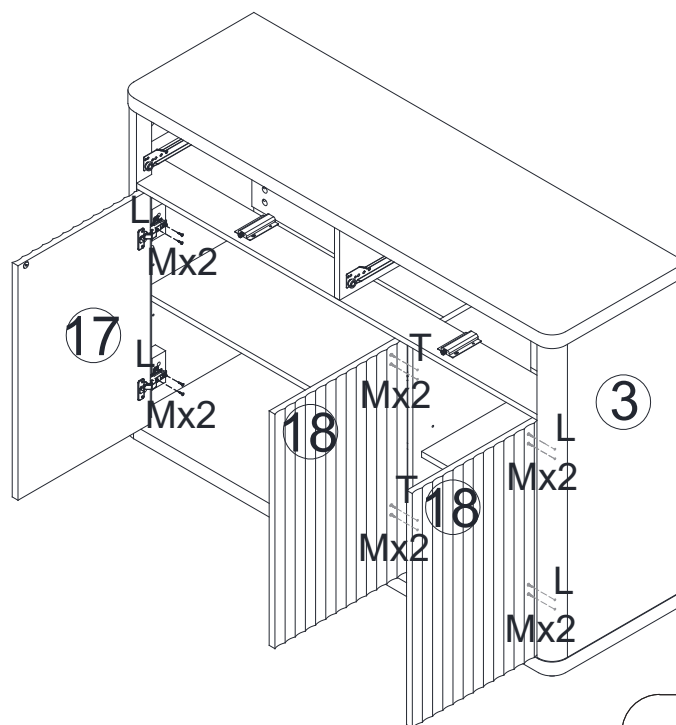

- |   |   |     |   |   |     |
|---|---|-----|---|---|-----|
| Q |  | X 2 | L |    | X 4 |
|   |   |     | M |  | X 8 |

# Step 34



- |   |   |      |
|---|---|------|
| M |  | X 12 |
|---|---|------|

# Step 35

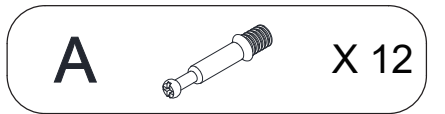
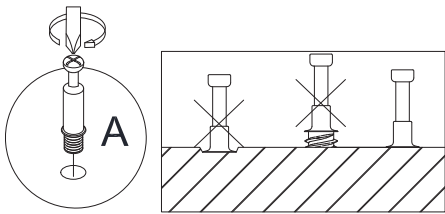
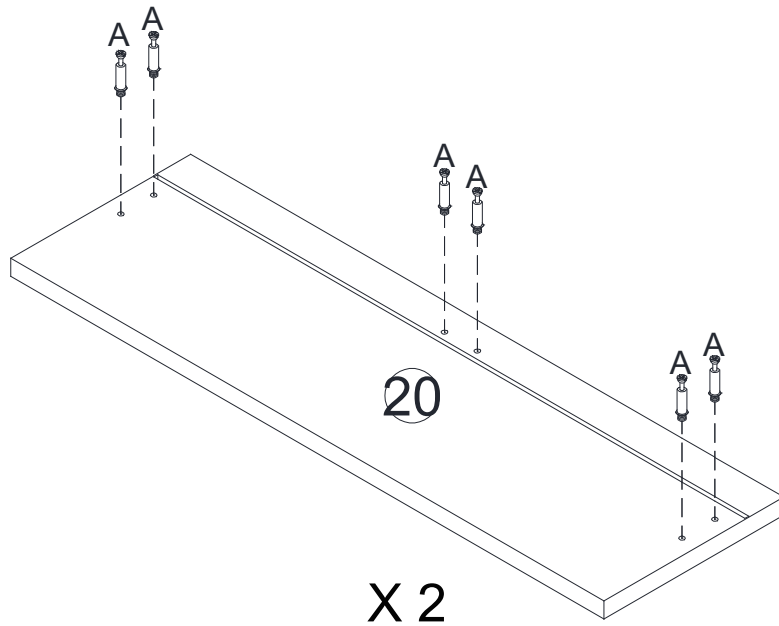

# Step 36

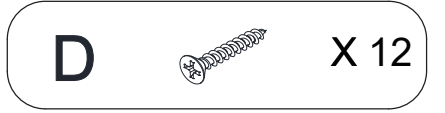
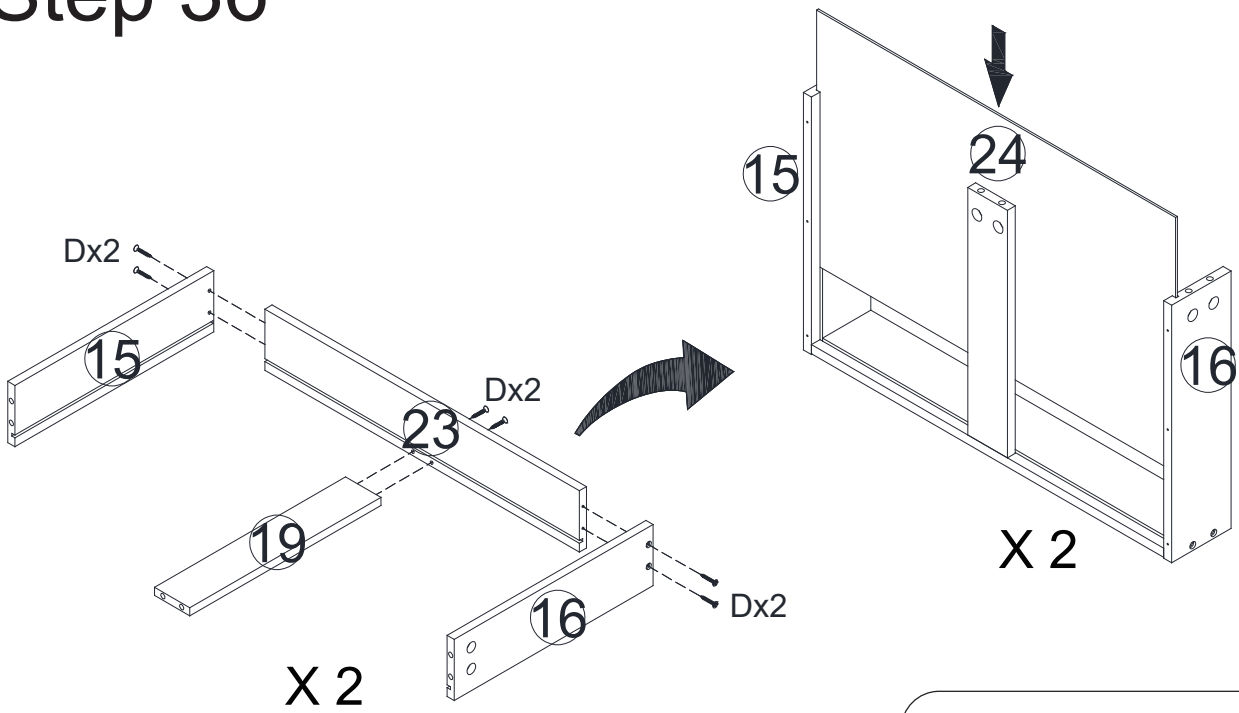

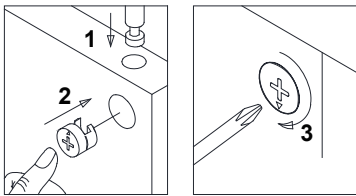
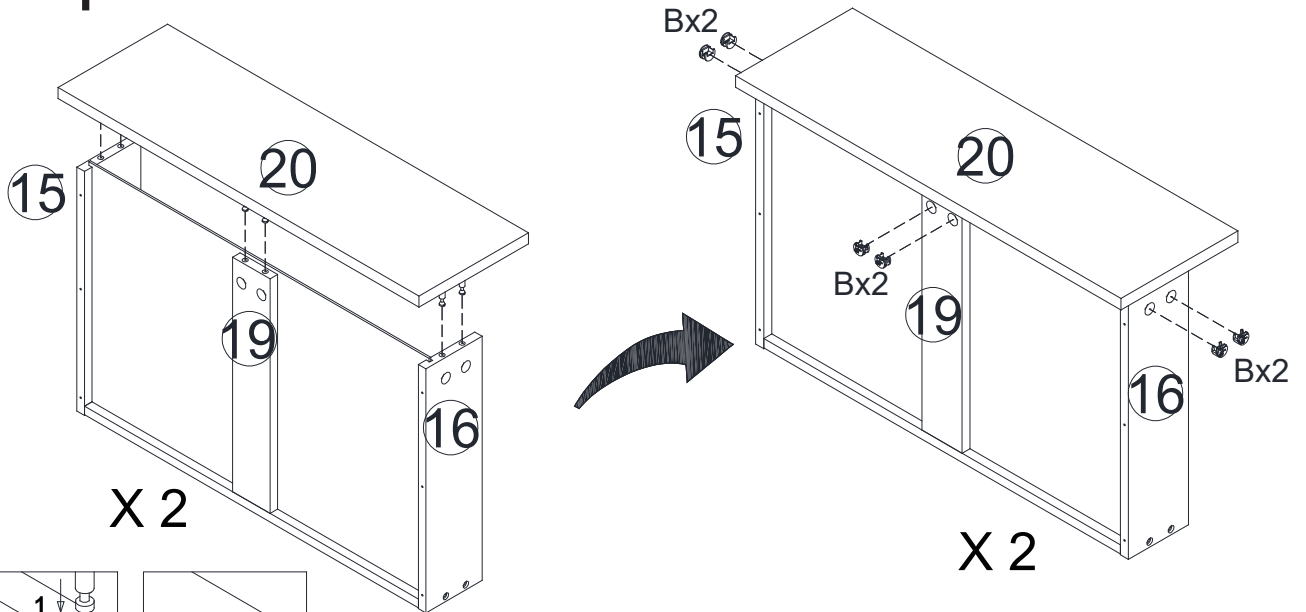

# Step 37



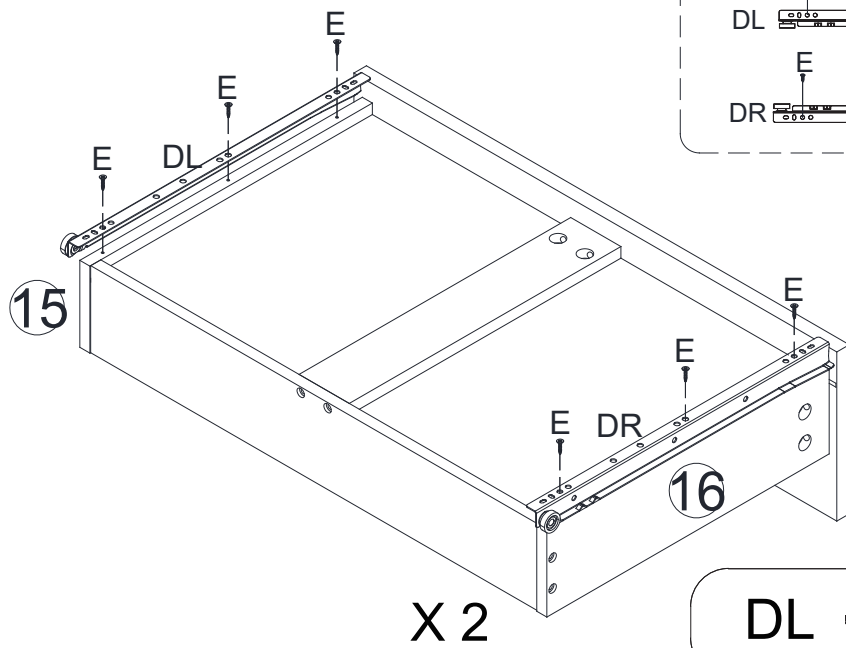

**B**  X 12

# Step 38



**E**  X 12

**DL**  X 2

**DR**  X 2

# Step 39

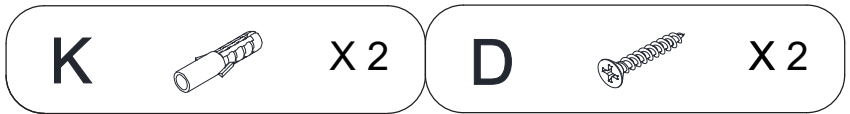
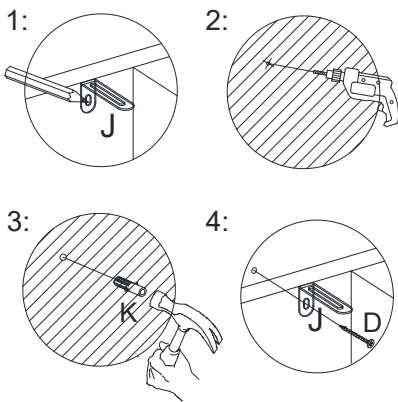
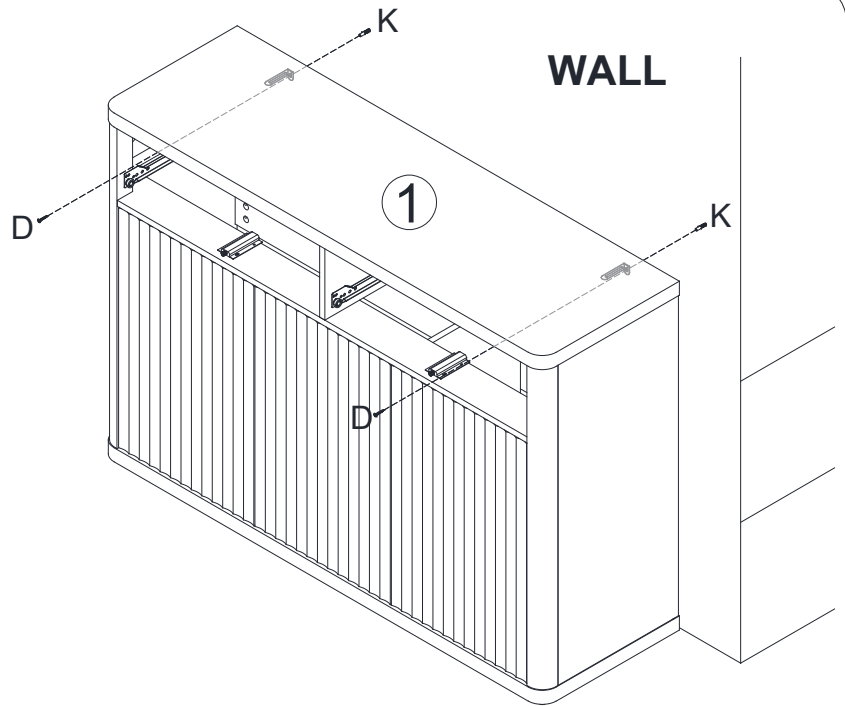

# Step 40

Please note that the drawers must be installed as indicated by the arrows.

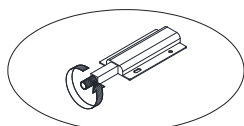
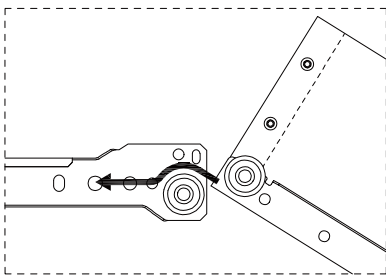

Note: You can adjust the knob of the bouncer to control the bouncing effect.

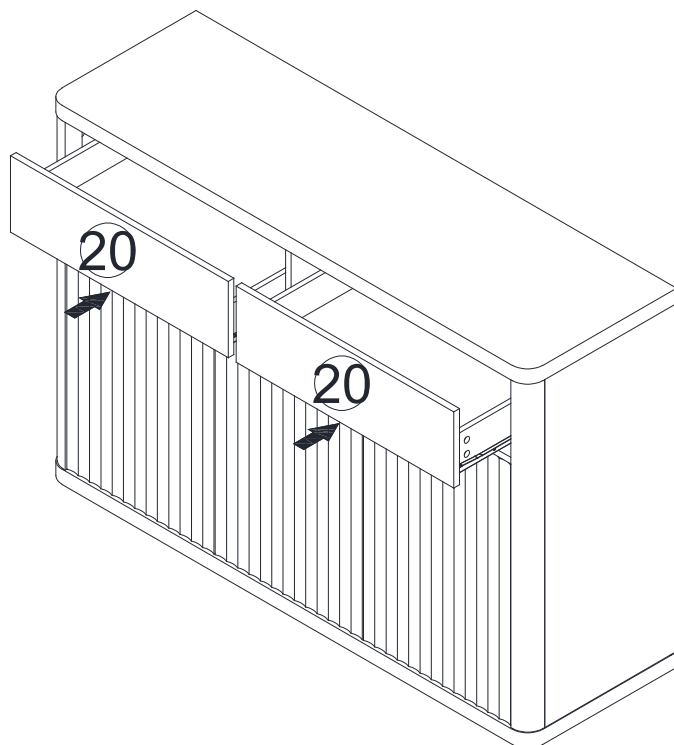

# Step 41

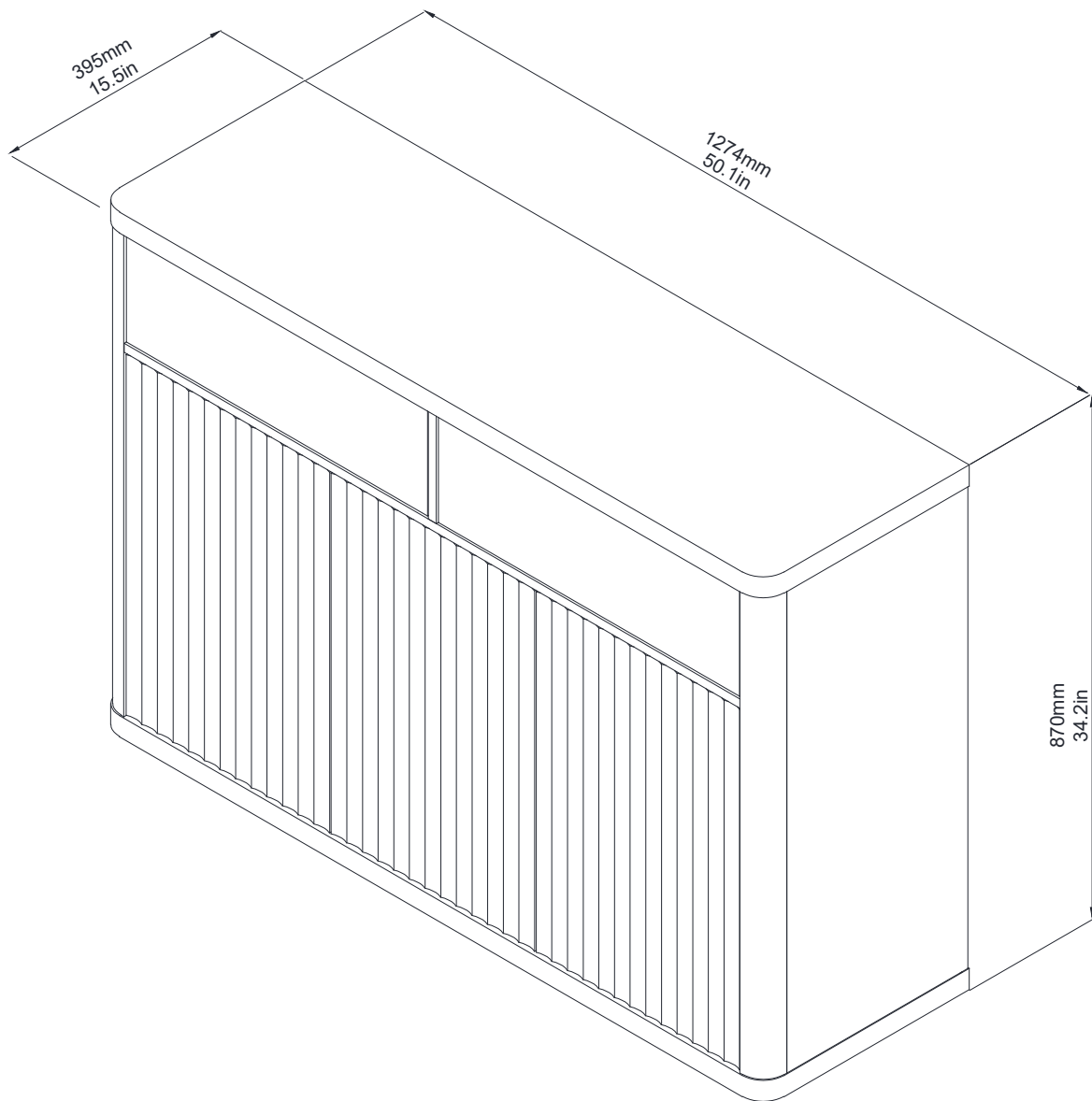

Final assmebly

# Cabinet Door Adjustment Instructions

Height adjustment:

- Locate the height adjustment screws on the hinge.
- Use the Phillips screwdriver to either tighten or loosen the screws to raise or lower the cabinet door as desired.

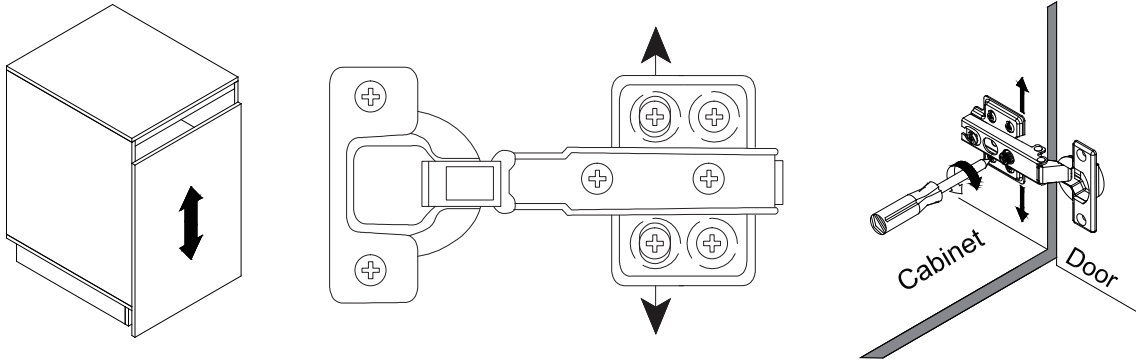

Side-to-side adjustment:

- If the cabinet door needs to be moved closer to or away from the cabinet frame, locate the side-to-side adjustment screws on the hinge.
- Use the Phillips screwdriver to adjust these screws and gradually move the door in the desired direction.

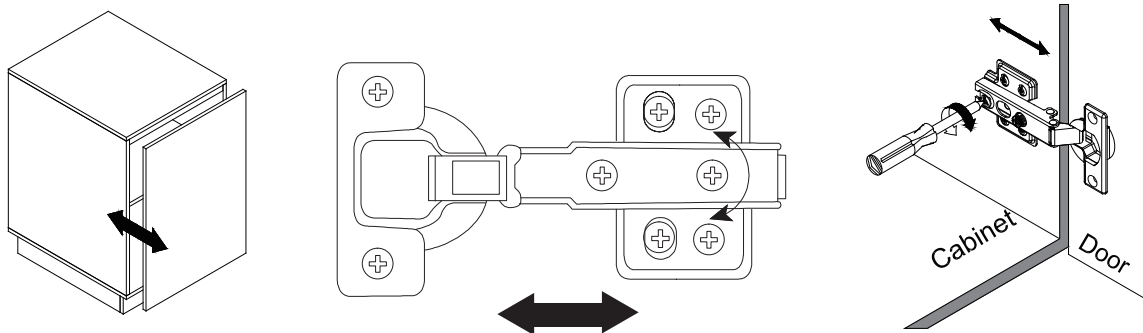

Depth adjustment (if applicable):

- Check if the cabinet door needs to be brought closer to or further away from the cabinet frame.
- For-depth adjustment, locate the depth adjustment screws on the hinge.
- Use the Phillips screwdriver to turn these screws clockwise or counterclockwise accordingly.

