

# - AMT0326 -

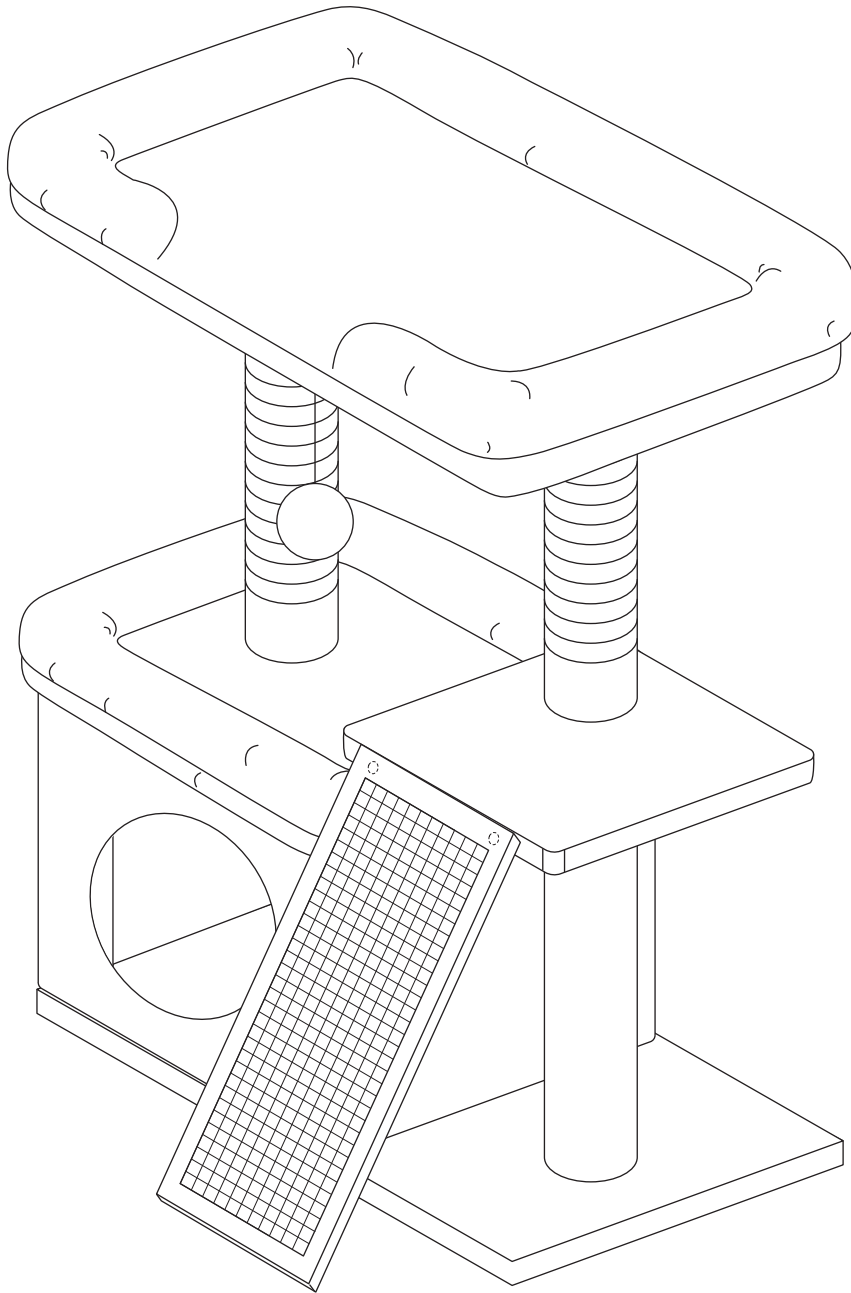

**EN** - Need help? Contact us:

**CN** - 需要帮助？联系我们：

**DE** - Brauchen Sie Hilfe? Kontaktieren Sie uns:

**FR** - Besoin d'aide ? Contactez-nous :

**IT** - Ha bisogno di aiuto? Contattaci:





**ES** - ¿Necesitas ayuda? Contáctanos:

**NL** - Hulp nodig? Neem contact met ons op:

**JP** - お困りですか？いつでもお気軽にお問い合わせください:

**KR** - 도움이 필요하신가요? 연락하세요:

✉ - [pawzroad@gmail.com](mailto:pawzroad@gmail.com)

x12	x1	x1	x2	x4
				
W1 : 35*8mm	W2 : 80*8mm	W3 : $\Phi$ 25mm	W4 : 120°	W5 : 16*6mm

x1

W6

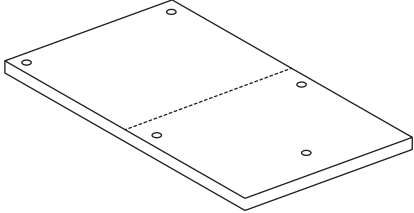

**A** 480\*300\*12mm(x1)

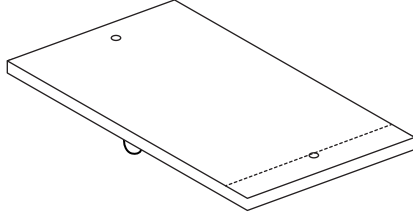

**B** 480\*300\*12mm(x1)

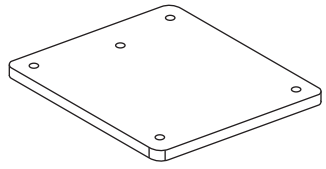

**C** 340\*300\*12mm(x1)

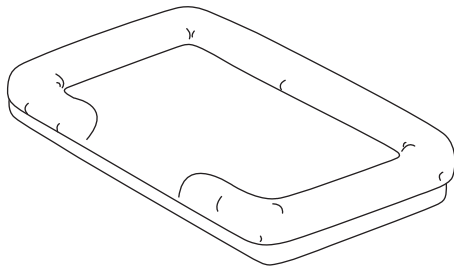

**D** (x1)

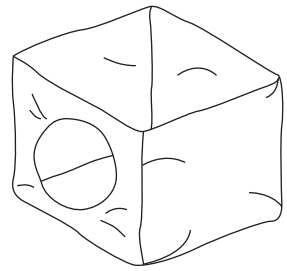

**E** (x1)

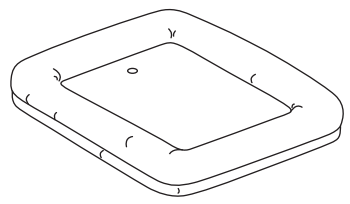

**F** (x1)



**G** 340\*45mm(x1)

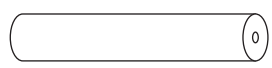

**H** 340\*45mm(x1)



**I** 245\*45mm(x1)

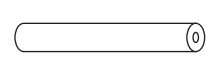

**J** 245\*25mm(x4)

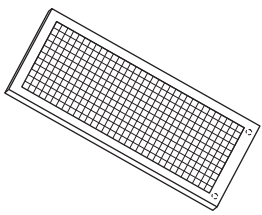

**K** 400\*150\*12mm(x1)

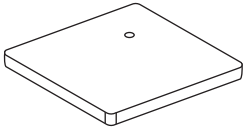

**L** 240\*200\*12mm(x1)

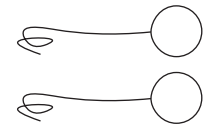

Replaceable Dangle Toy

**M** (x2)

1 W1  x8

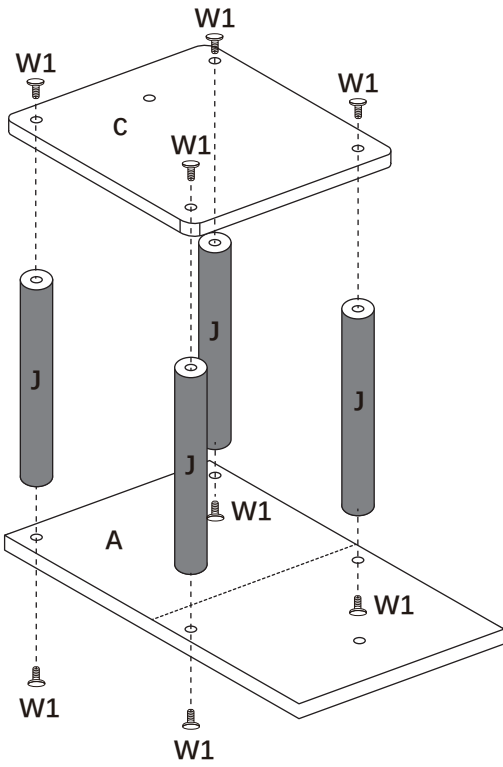

2

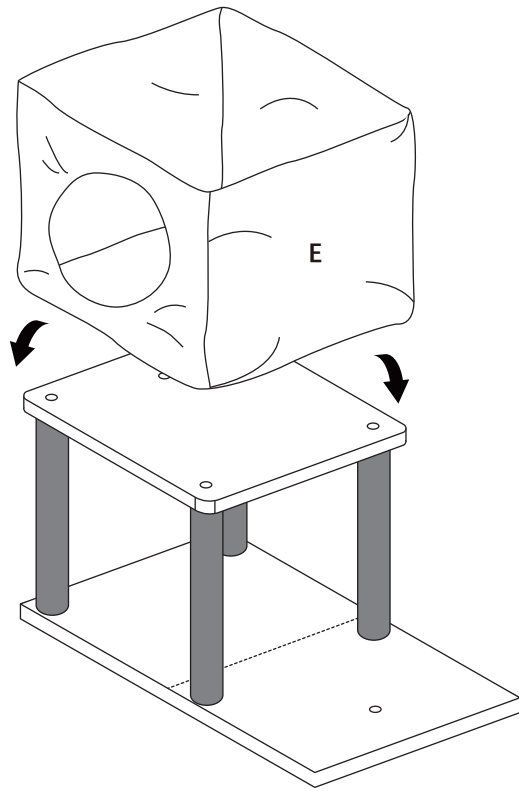

3

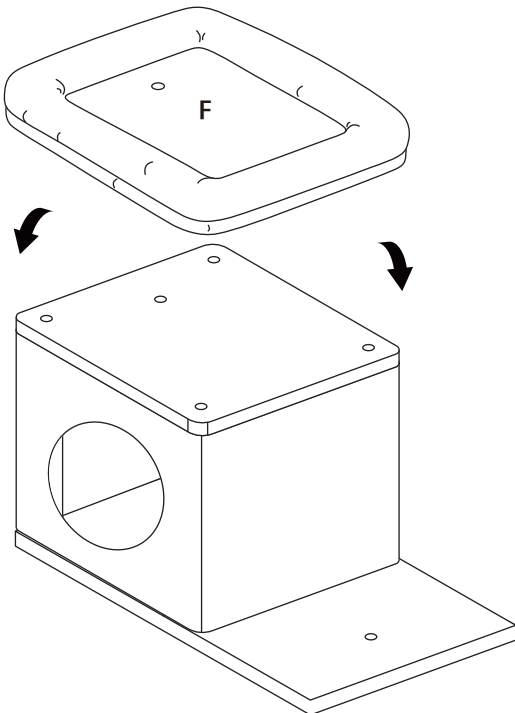

4

W1  x2 W2  x1

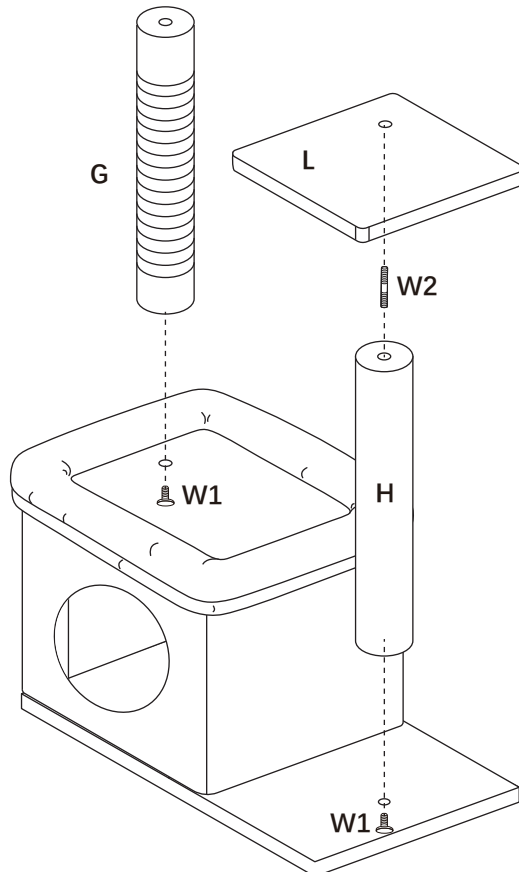

3

5

W4



x2

W5



x4

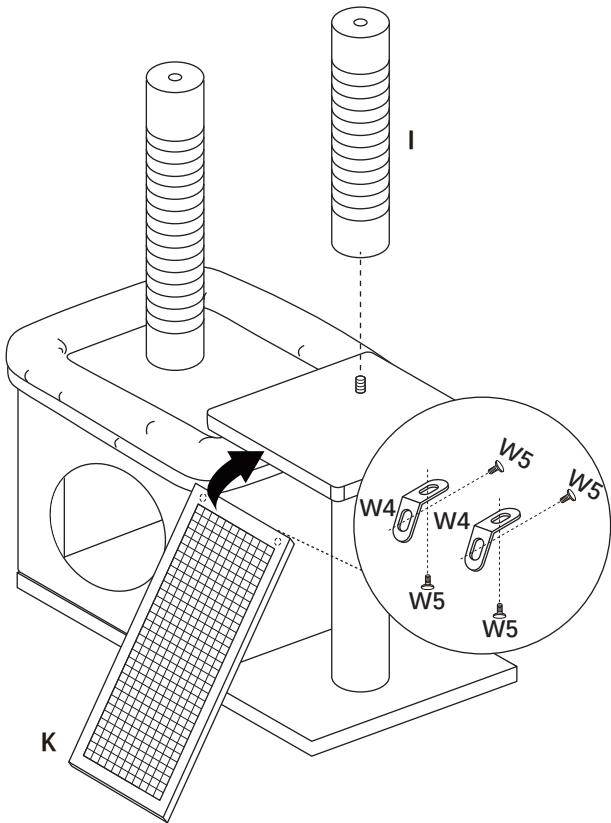

6

W1



x2

W3



x1

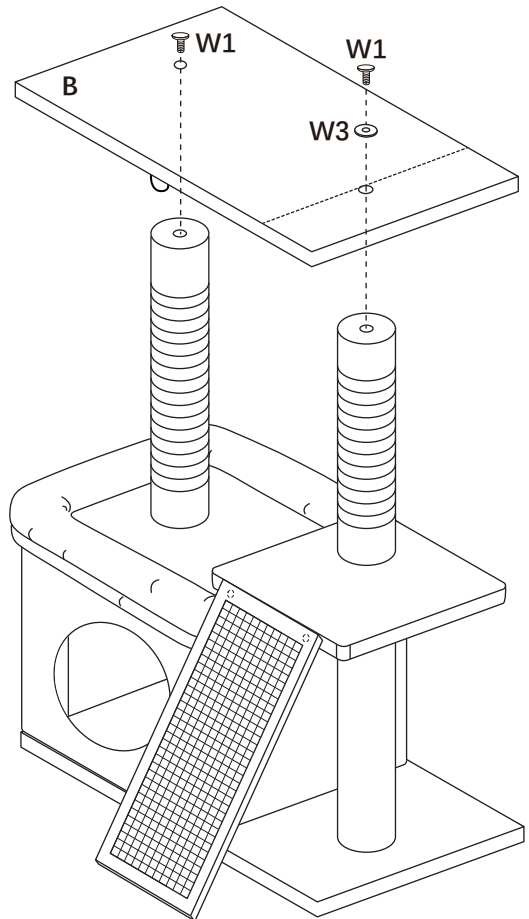

7

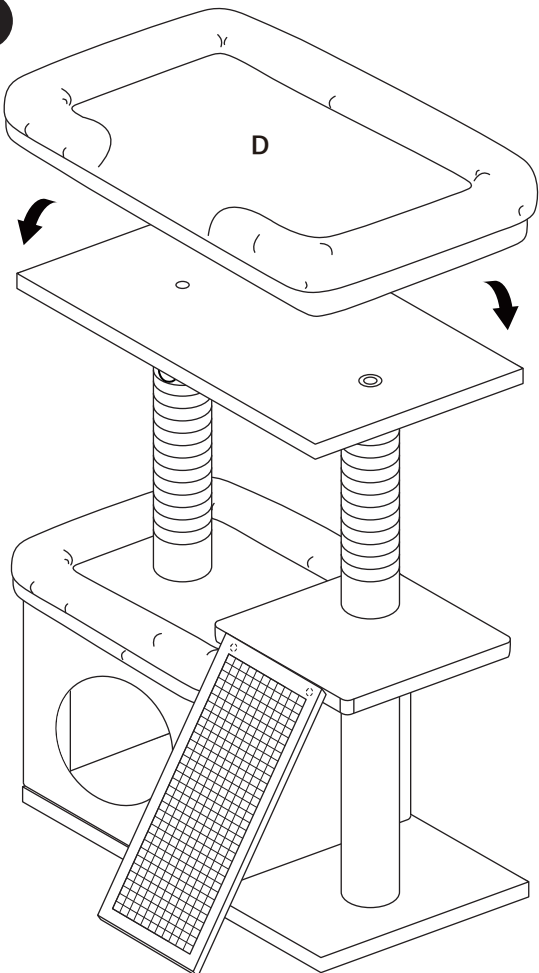

8

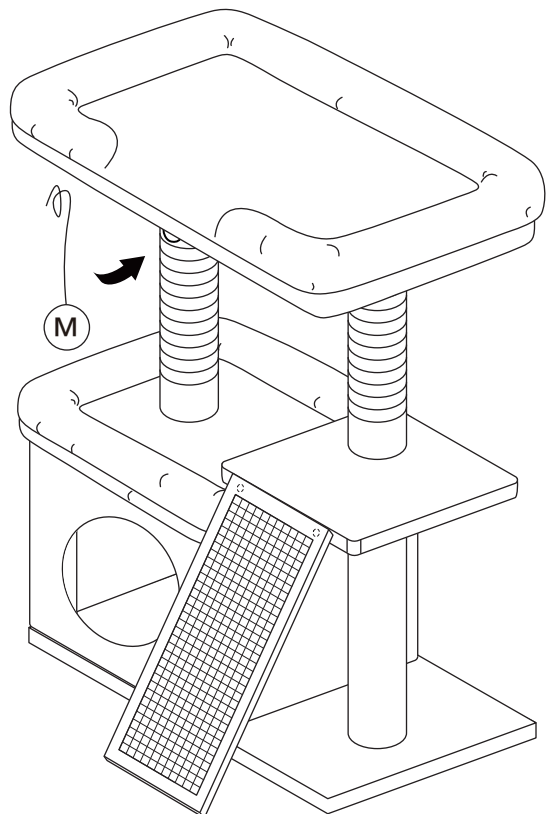



## IMPORTANT:



- Assemble on a flat surface
- Tighten all screws securely
- Place against a wall for added stability
- Supervise your cat's first use
- **Warning:** Keep away from fire.
- Keep plastic bag away from children.



## 注意事项:



- 在平稳地面安装
- 确保所有螺丝拧紧
- 建议靠墙放置，增强稳定性
- 初次使用，建议观察猫咪适应情况
- **警告：** 远离火源，将塑料袋放在儿童接触不到的地方。



## WICHTIG:



- Auf einer flachen Oberfläche montieren
- Alle Schrauben fest anziehen
- Zur zusätzlichen Stabilität an eine Wand stellen
- Beaufsichtigen Sie den ersten Einsatz Ihrer Katzen
- **Warnung:** Von Feuer fernhalten.
- Plastiktüte von Kindern fernhalten.



## IMPORTANT:



- Assemblez sur une surface plane
- Serrez fermement toutes les vis
- Placez contre un mur pour plus de stabilité
- Surveillez la première utilisation par votre chat
- **Avertissement :** Tenez éloigné du feu.
- Gardez le sac en plastique hors de portée des enfants.



## IMPORTANTE:



- Assemblare il prodotto su una superficie piana
- Serrare bene tutte le viti
- Posizionare il prodotto contro una parete per maggiore stabilità
- Sorvegliare il gatto durante il primo utilizzo
- **Avvertenza:** Tenere lontano da fiamme.
- Tenere il sacchetto di plastica lontano dai bambini.



## IMPORTANTE:



- Ensamblar sobre una superficie plana
- Asegurar que todos los tornillos estén bien apretados
- Colocar contra una pared para mayor estabilidad
- Supervisar el primer uso de su gato
- **Advertencia:** Mantener alejado del fuego.
- Mantener la bolsa de plástico fuera del alcance de los niños.



## BELANGRIJK:



- Monteer op een vlakke ondergrond
- Draai alle schroeven stevig vast
- Plaats tegen een muur voor extra stabiliteit
- Houd toezicht op het eerste gebruik van uw katten
- **Waarschuwing:** Uit de buurt van vuur houden.
- Houd de plastic zak weg bij kinderen.



## ご注意:



- 平らな床で組み立てる
- すべてのネジをしっかり締める
- 安定性を高めるために壁に寄せて設置する
- 初使用の場合は猫ちゃんの状態を見守る。
- **警告：** 火気厳禁。
- ビニール袋を子供の手の届かないところに保管してください。



## 중요:



- 평지에서 조립하세요.
- 모든 나사를 단단히 조이세요
- 안정성을 높이기 위해 벽에 기대어 두세요
- 처음 사용하는 경우 고양이의 적응력을 살펴보세요.
- **경고:** 화기엄금.
- 비닐봉지는 어린이의 손이 닿지 않는 곳에 보관하세요.

