

ASSEMBLY INSTRUCTIONS



Fine Furniture for every stage of life

Queen Bed

REVISION 0: 06/01/2023
REVISION 1: 12/01/2023

ASSEMBLY INSTRUCTIONS

ASSEMBLY TIPS:

1. Remove hardware from box and sort by size.
2. Please check to see that all hardware and parts are present prior to start of assembly.
3. Please follow attached instructions in the same sequence as numbered to assure fast & easy assembly.



WARNING!

1. Don't attempt to repair or modify parts that are broken or defective. Please contact the store immediately.
2. This product is for home use only and not intended for commercial establishments.

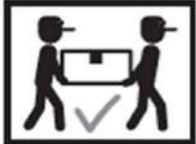

ASSEMBLY TIME

30 MINUTES

PARTS IDENTIFICATION

B1 (BOX1)

AN HEADBOARD

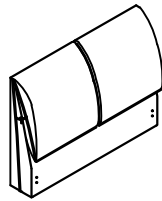

1PC

B2 (BOX2)

BN FOOTBOARD

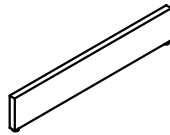

1PC

DN CENTER RAIL

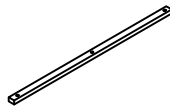

1PC

FN CENTER RAIL SUPPORT
WITH LEVELER



3PCS

CN BED RAIL



2PCS

EN ROLL SLAT
(13PCS)

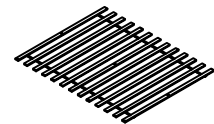

1SET

HARDWARE IDENTIFICATION

Z-B2 (BOX2) - HARDWARE PACK IS LOCATED IN (B2)

1 BOLT
(Ø5/16"x38mm - RBW)



8PCS

2 FLAT WASHER
(Ø5/16" - RBW)



8PCS

3 LOCK WASHER
(Ø5/16" - RBW)



8PCS

4 PAN HEAD SCREW
(M4 x 30mm - RBW)



8PCS

5 ALLEN WRENCH
(5mm - RBW)



1PC

NOTE:

Phillips head screw driver is required in the assembly process; however, manufacturer does not provide this item.

ASSEMBLY INSTRUCTIONS

STEP 1

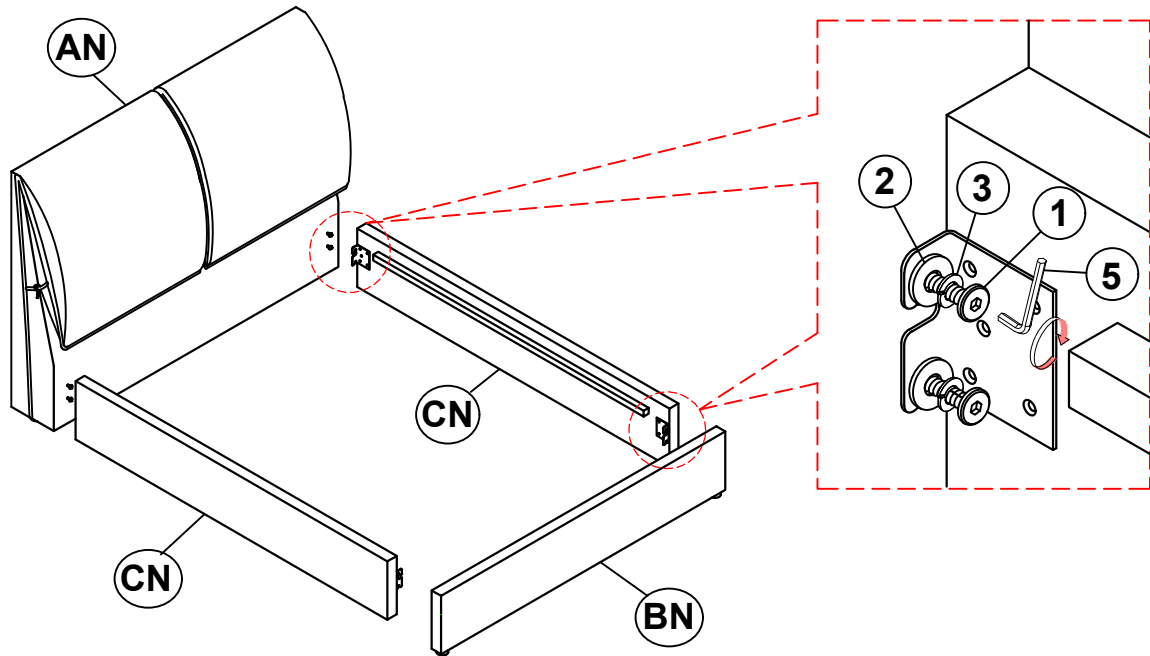

STEP 2

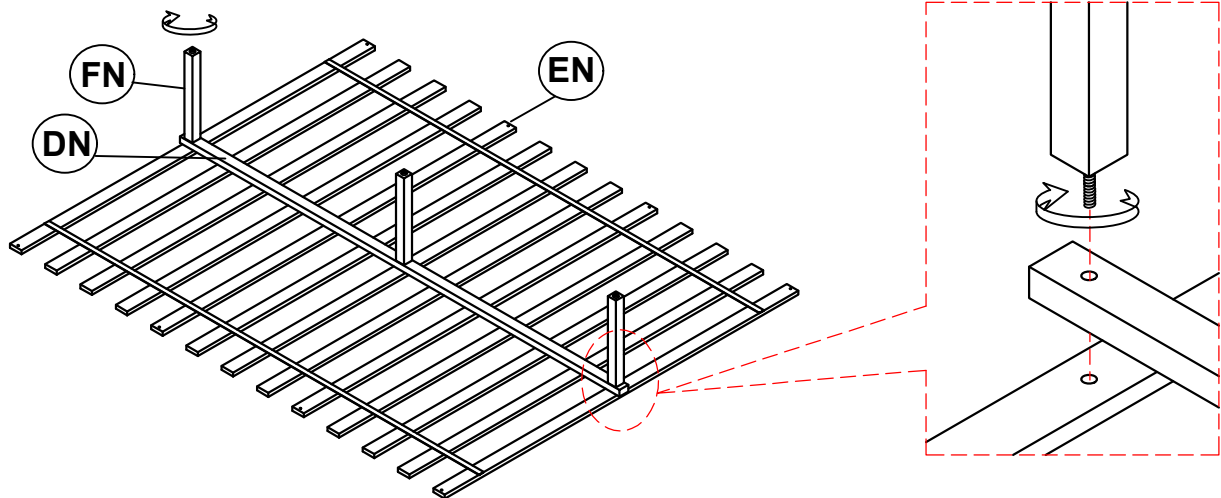

ASSEMBLY INSTRUCTIONS

STEP 3

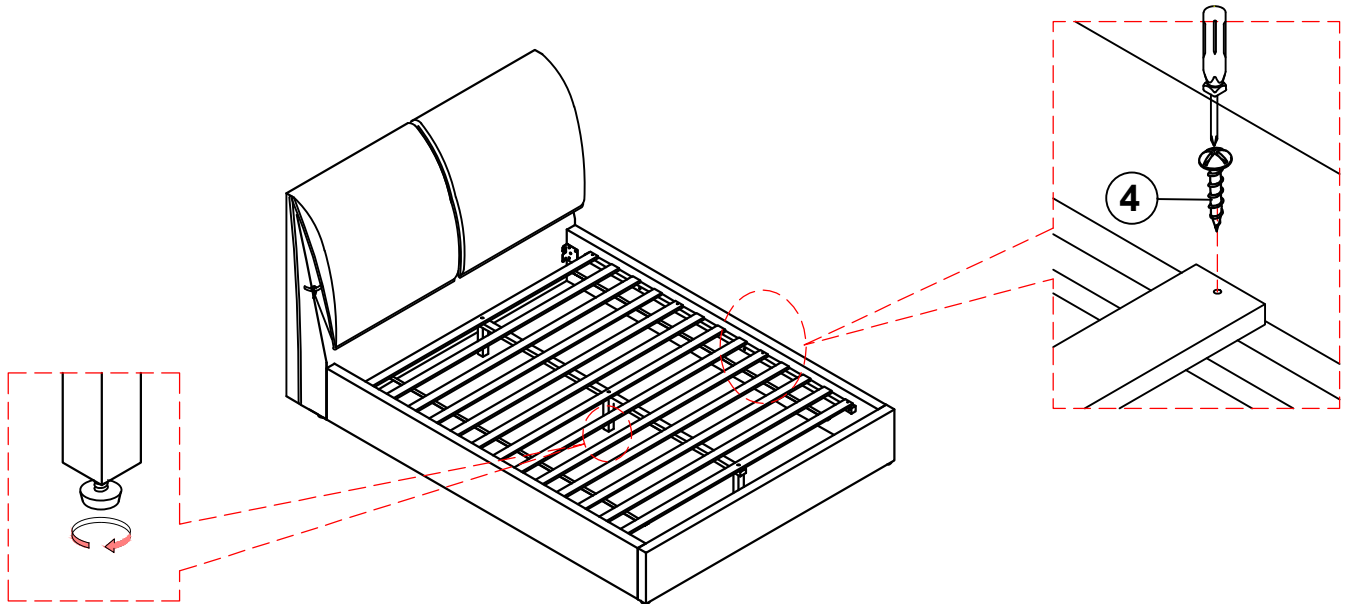

STEP 4 COMPLETE

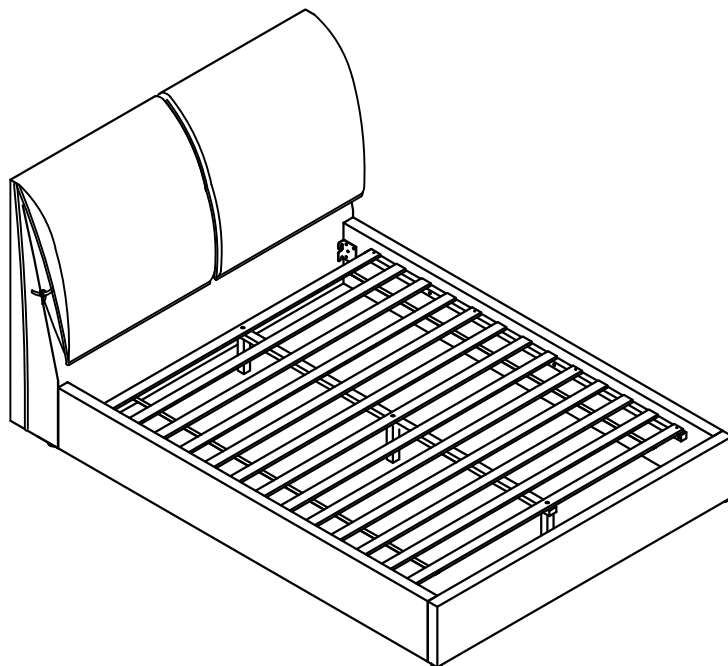

Inner Size: 61.00"W X 81.25"D

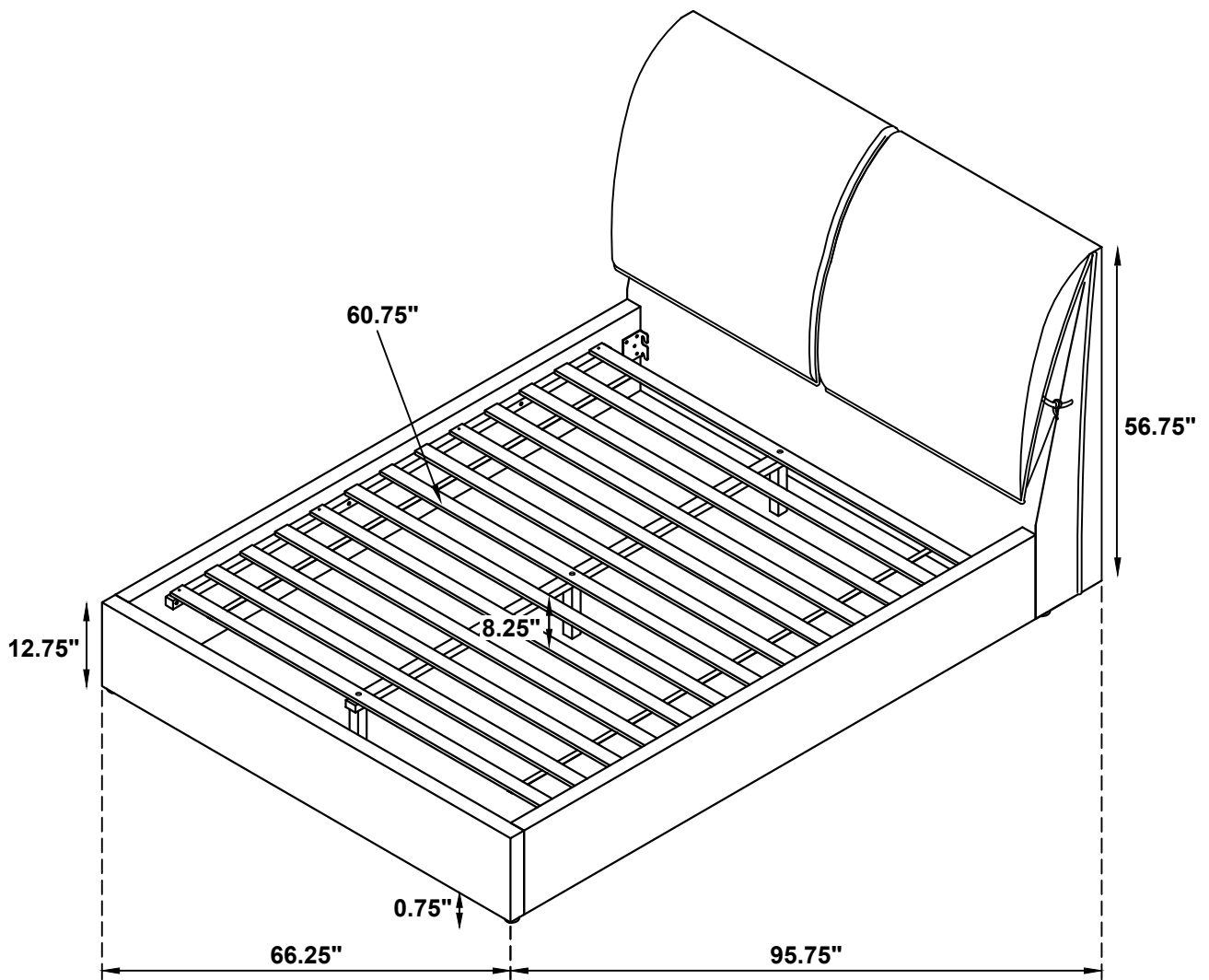

Note: Dimension tolerance $\pm 5\%$