

ASSEMBLY INSTRUCTIONS

Important Safety Instructions:

- Please read all instructions before beginning assembly
- Please make sure receive all the parcels to start the assembly
- For your safety and convenience, assembly by two people is recommended
- Use the parts and hardware lists to identify and separate each of the components included
- Save all packing materials until assembly is completed to avoid the accidental discarding of smaller parts or hardware

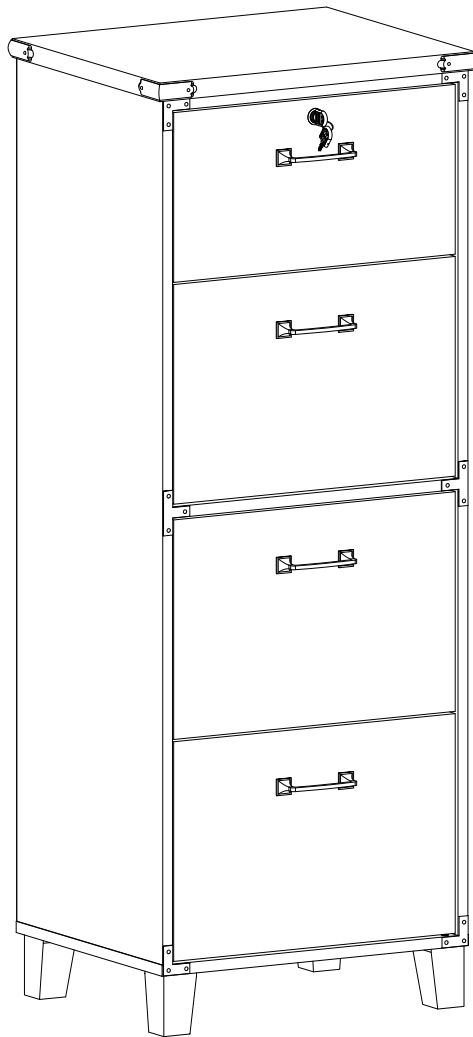





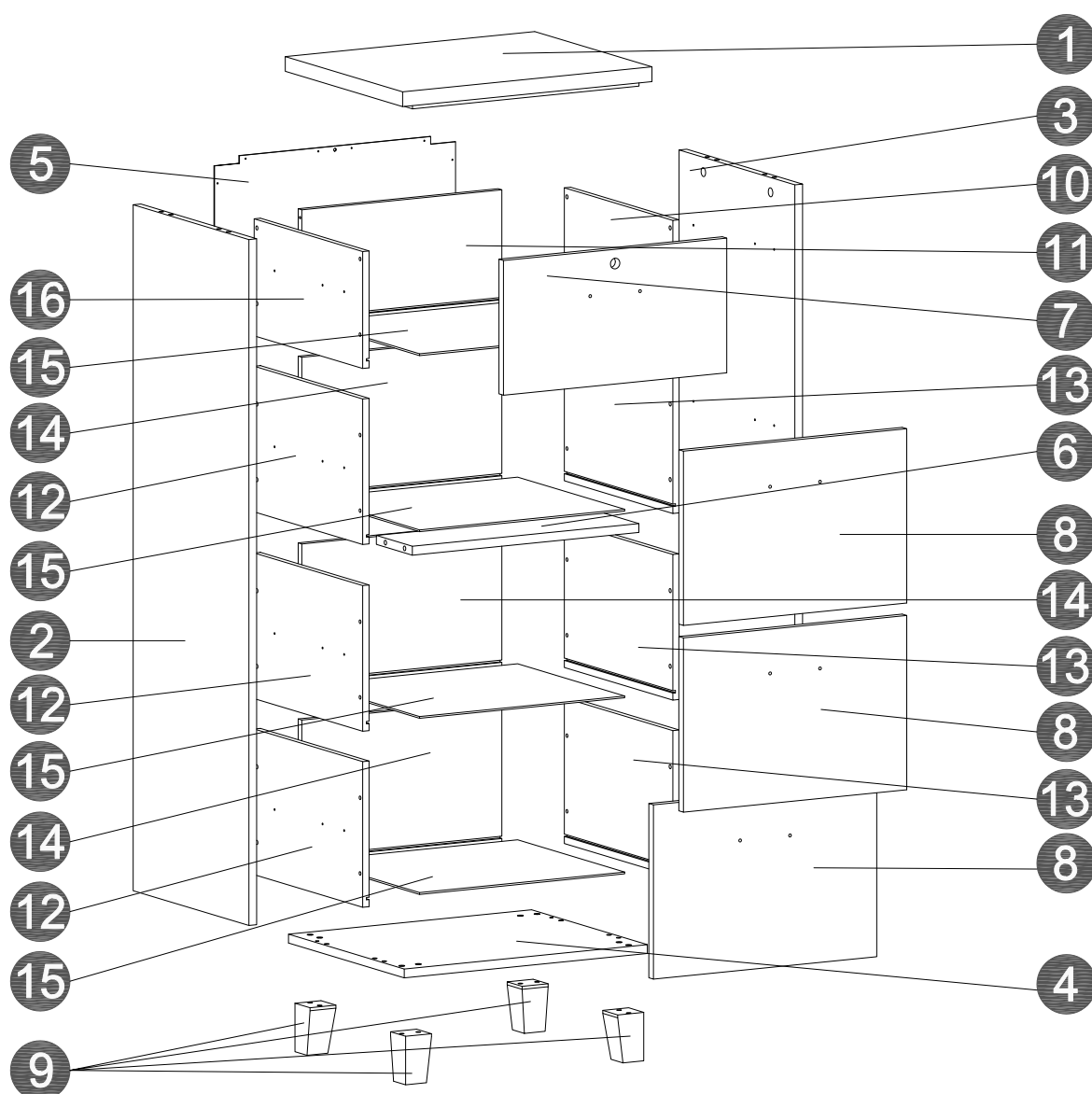

THANK YOU FOR PURCHASING



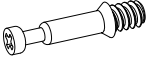

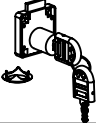

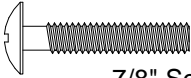

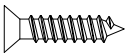
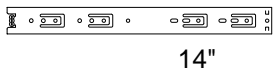
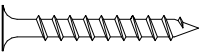
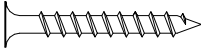
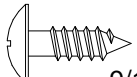
PARTS LIST

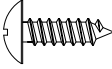
① X1	② X1	③ X1	④ X1	⑤ X1
⑥ X1	⑦ X1	⑧ X3	⑨ X4	⑩ X1
⑪ X1	⑫ X3	⑬ X3	⑭ X3	⑮ X4
⑯ X1				

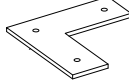
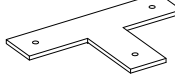

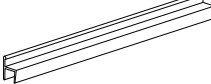
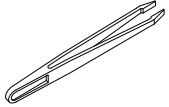
HARDWARE LIST

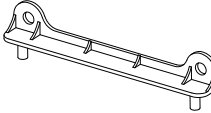
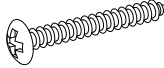
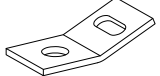
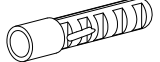
Name	Part	Qty.	Spare
A		6	1
B		6	1
C		10	1
D		1	
E		3	
F		4	
G	 7/8" Screw	8	1
H	 3/4" Nail	22	1
I	 5/8" Screw	4	
J	 14"	8	
K	 2" Screw	12	1
L	 1-1/2" Screw	16	1
M	 9/16" Screw	16	1

Name	Part	Qty.	Spare
N	 1/2" Screw	64	5
O		18	2
P		4	
Q		2	
R	 5/6" nail	8	2
S		4	
T		3	
U		1	
V		6	
DD		8	
U1		2	
U3		2	
U4		1	
U5		1	

**Slides Must Be Separated Before Assembly.
After Separated, Set Aside Until Needed for Assembly.**

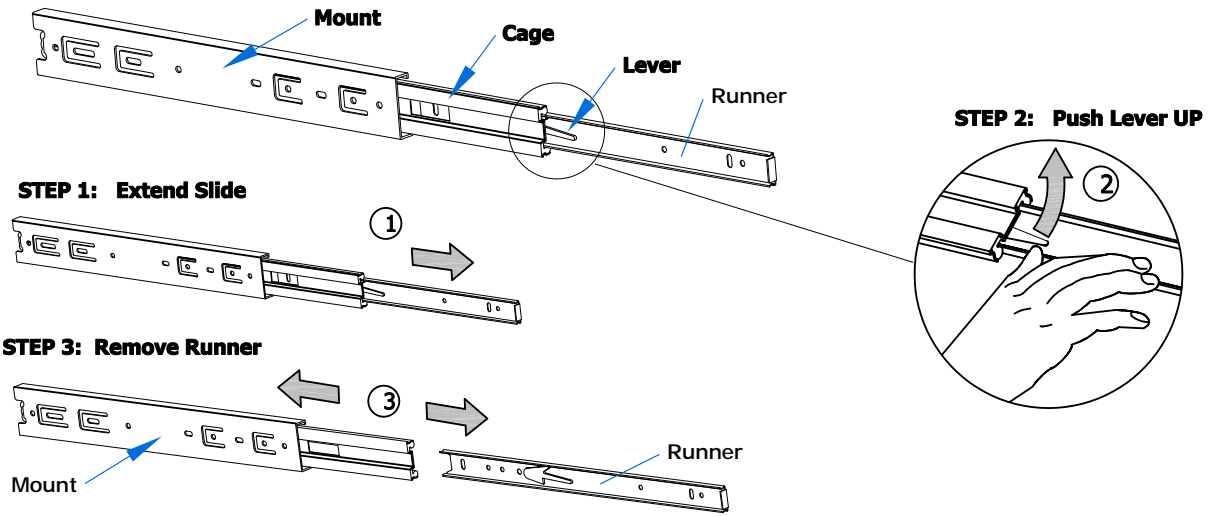

STEP 1

DD x 8pcs

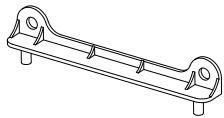

M x 16pcs

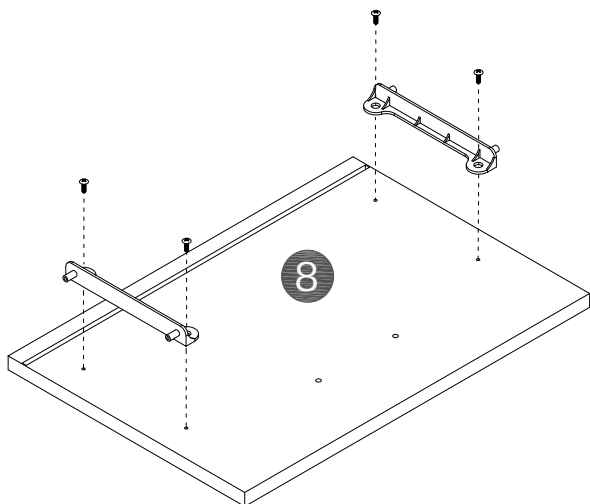
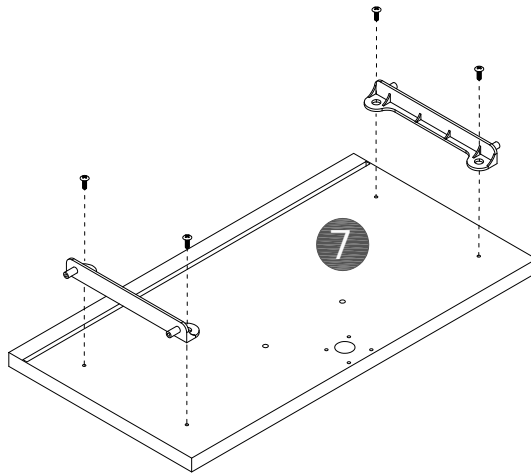
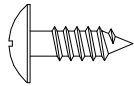

x3

STEP 2

N x 24pcs 

J x 8pcs

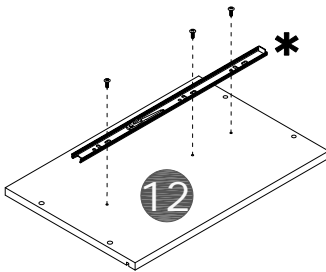
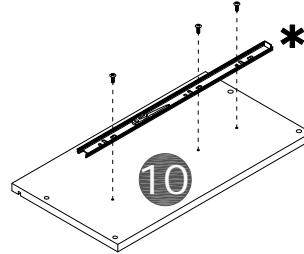
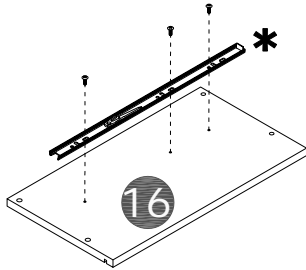
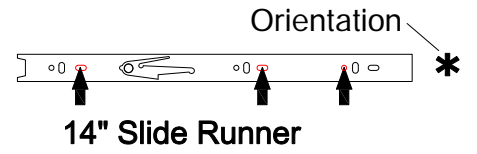

x3

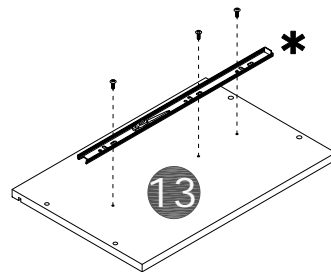

x3

STEP 3

N x 16pcs 

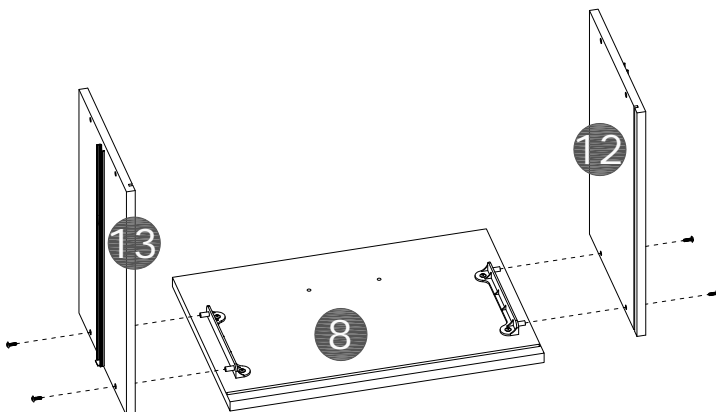
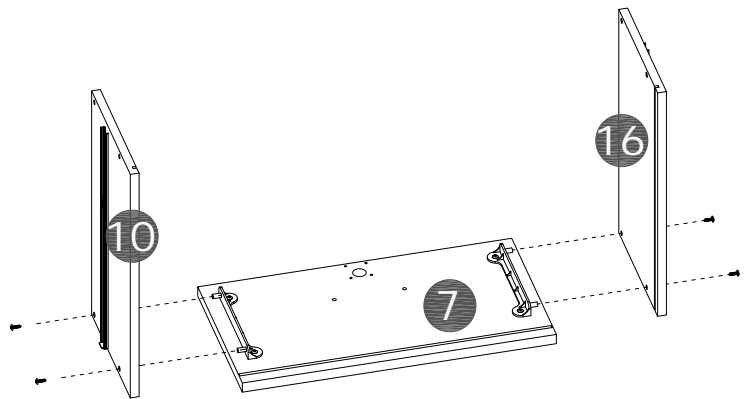

x3

STEP 4

L x 16pcs 

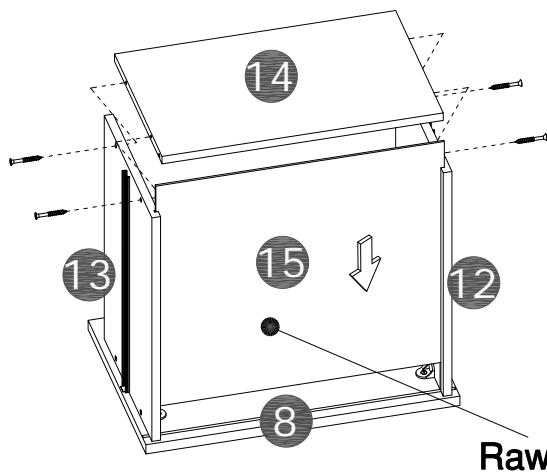

x 3

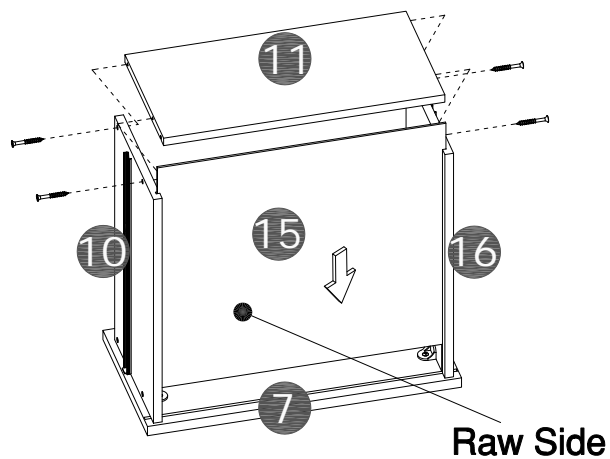

STEP 5

F x 4pcs 

G x 8pcs 

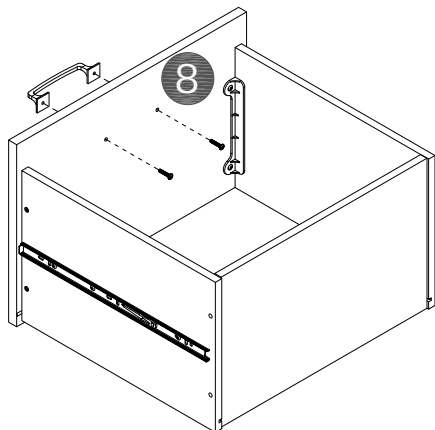

x 3

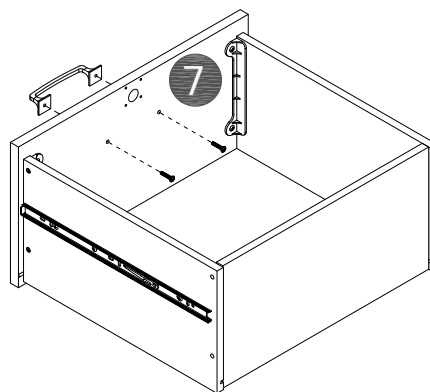

STEP 6

T x 3pcs

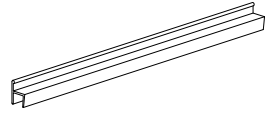

E x 3pcs



V x 6pcs

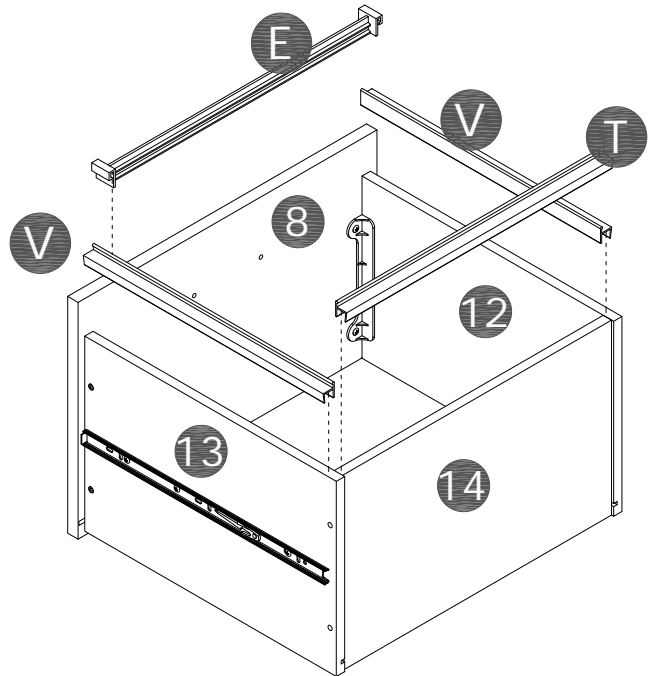
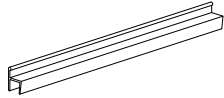

STEP 7

D x 1pc

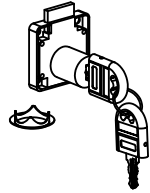

I x 4pcs

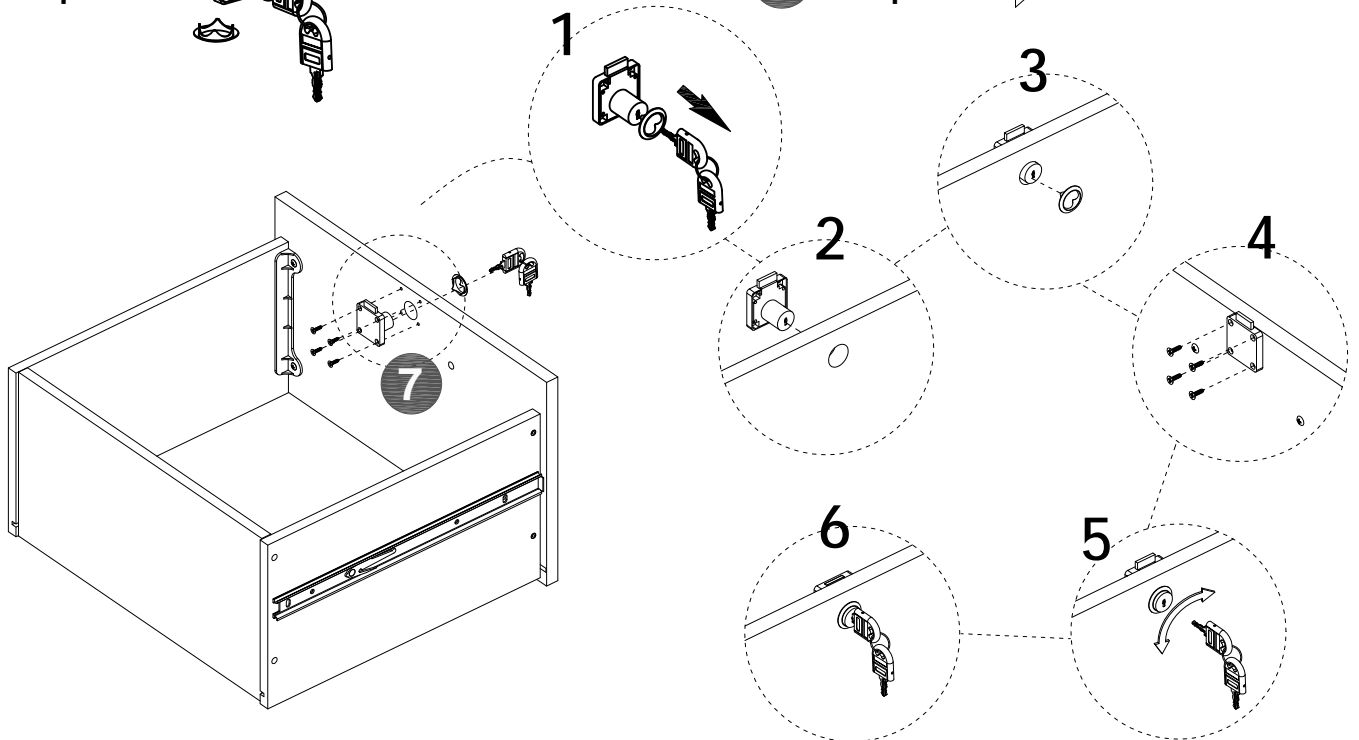
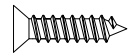

STEP 8

A x 6pcs 

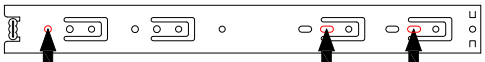
J x 8pcs  **Orientation** *
14" Slide Mount

C x 10pcs 

N x 24pcs 

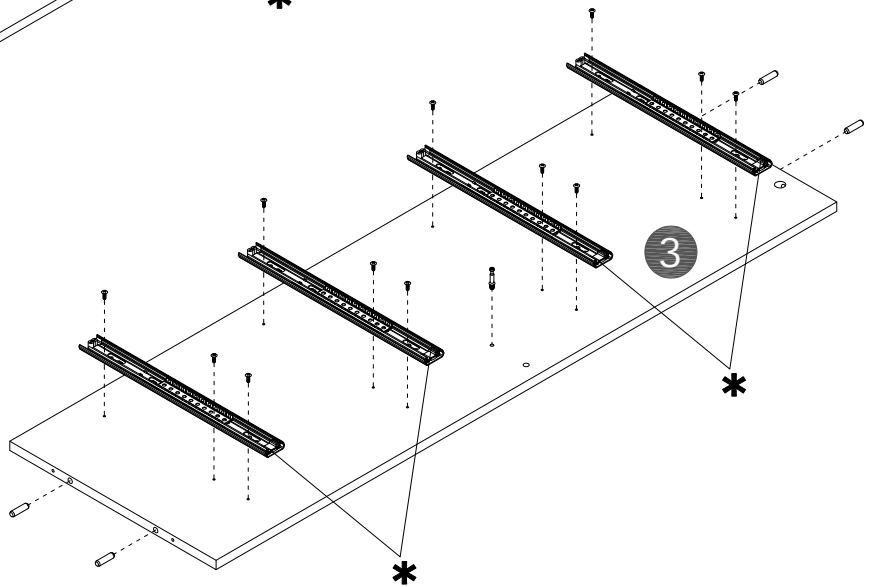
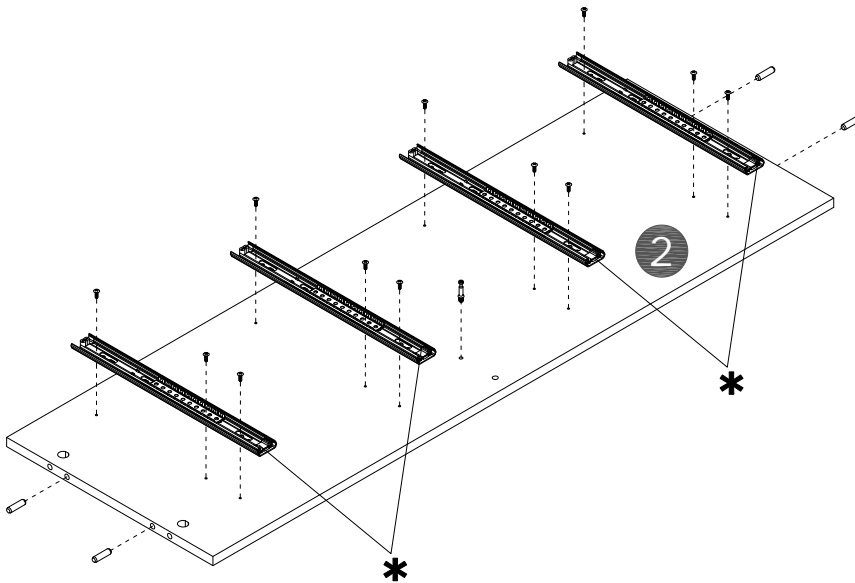
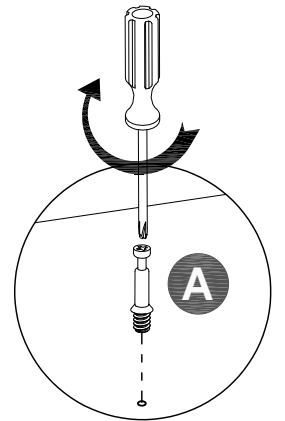
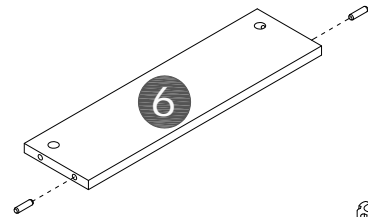
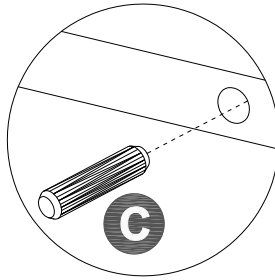
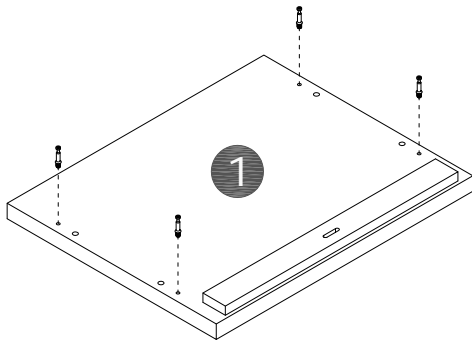

STEP 9

K x 8pcs

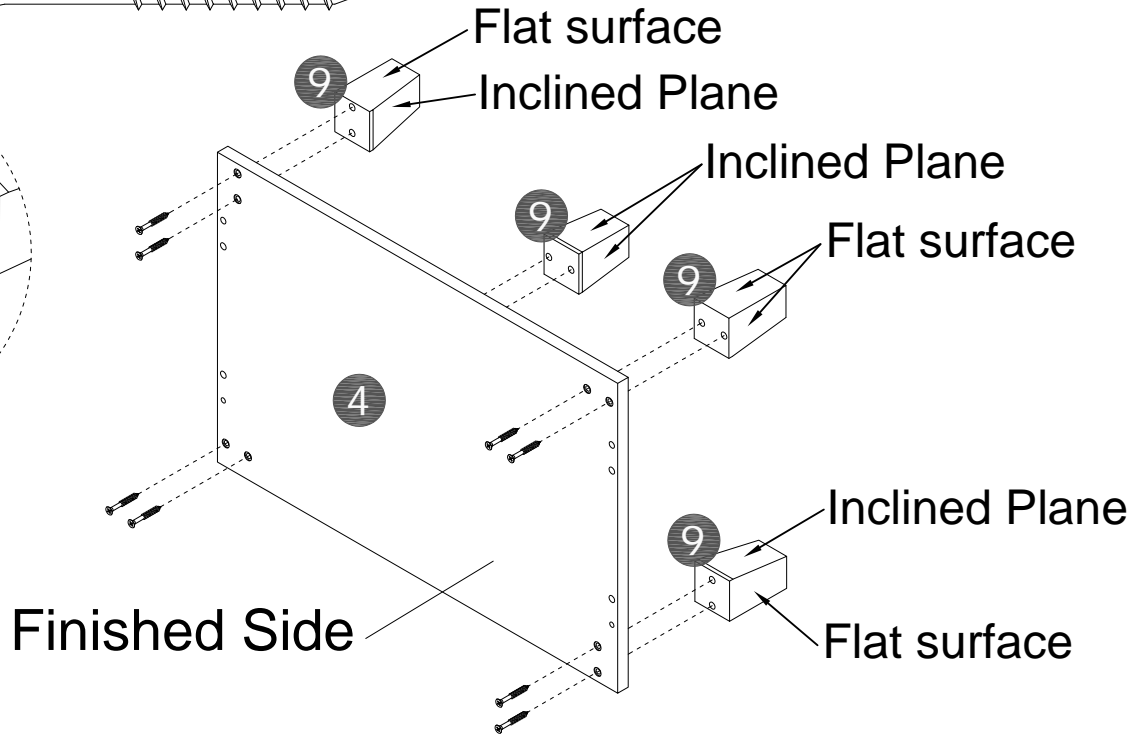
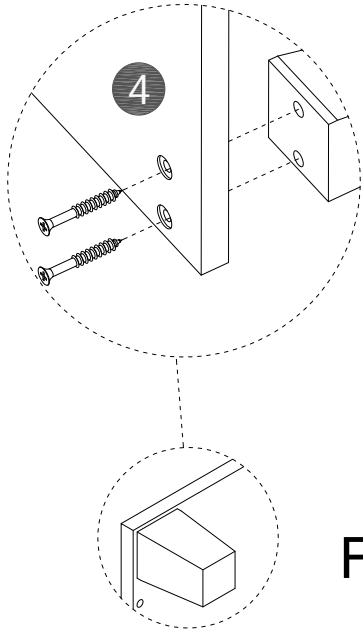
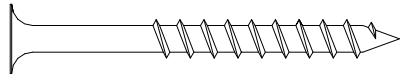

STEP 10

B x 2pcs

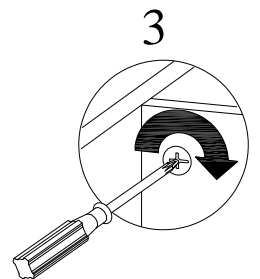
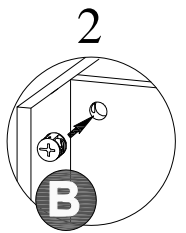
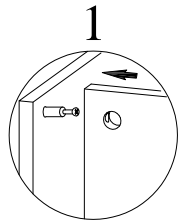
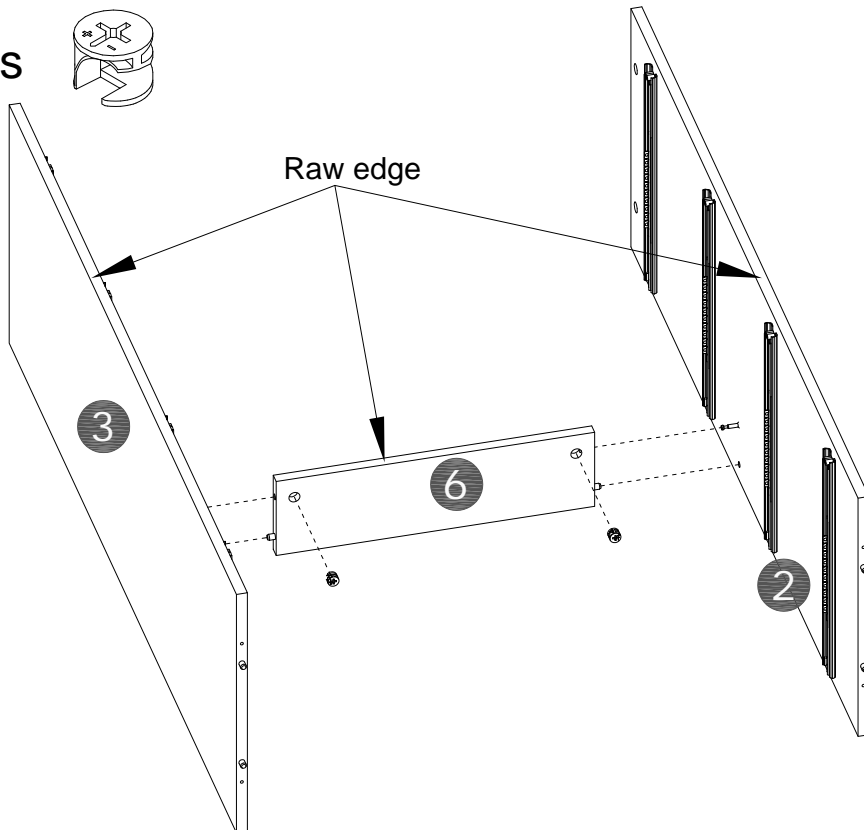
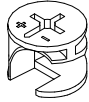

STEP 11

K x 4pcs

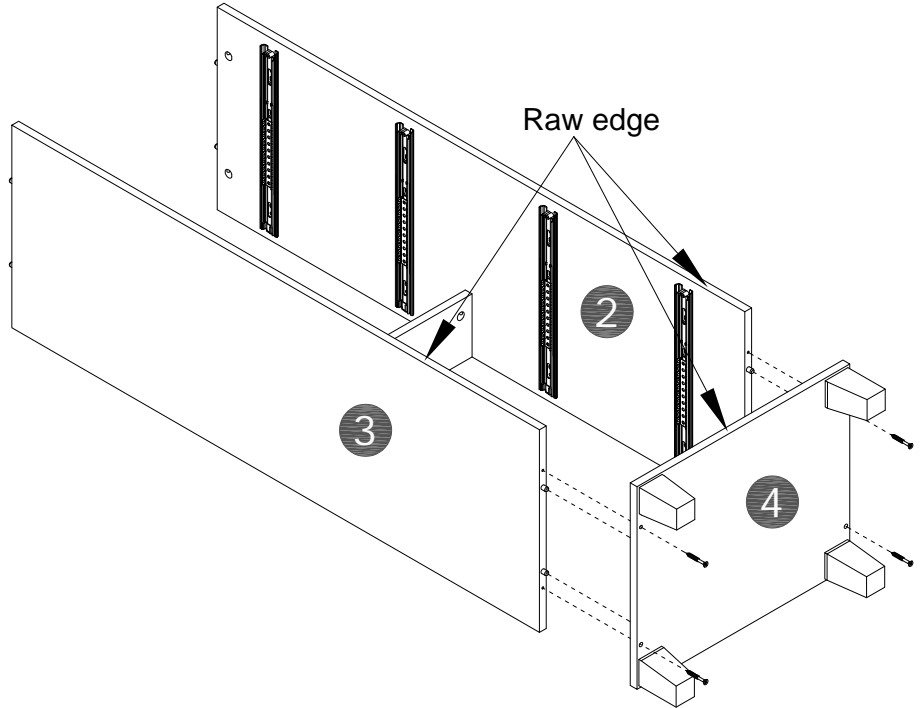
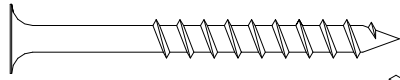

STEP 12

B x 4pcs

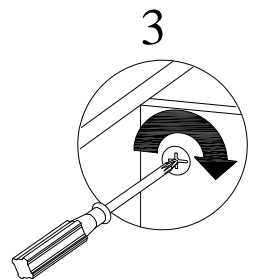
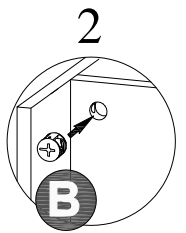
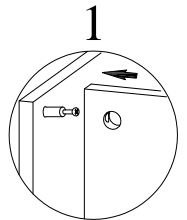
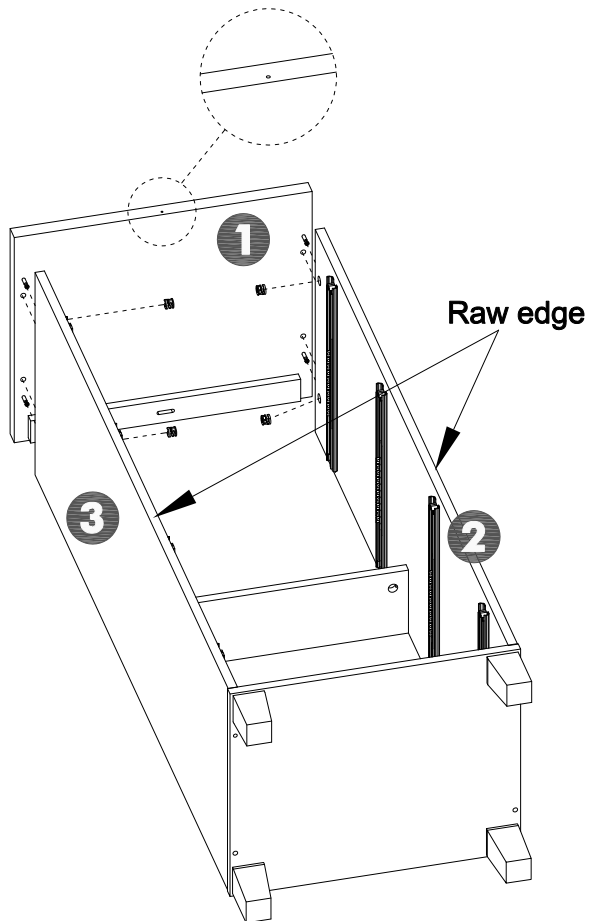

STEP 13

H x 22pcs 

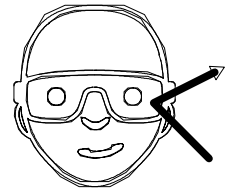

Safety glasses

No Screw

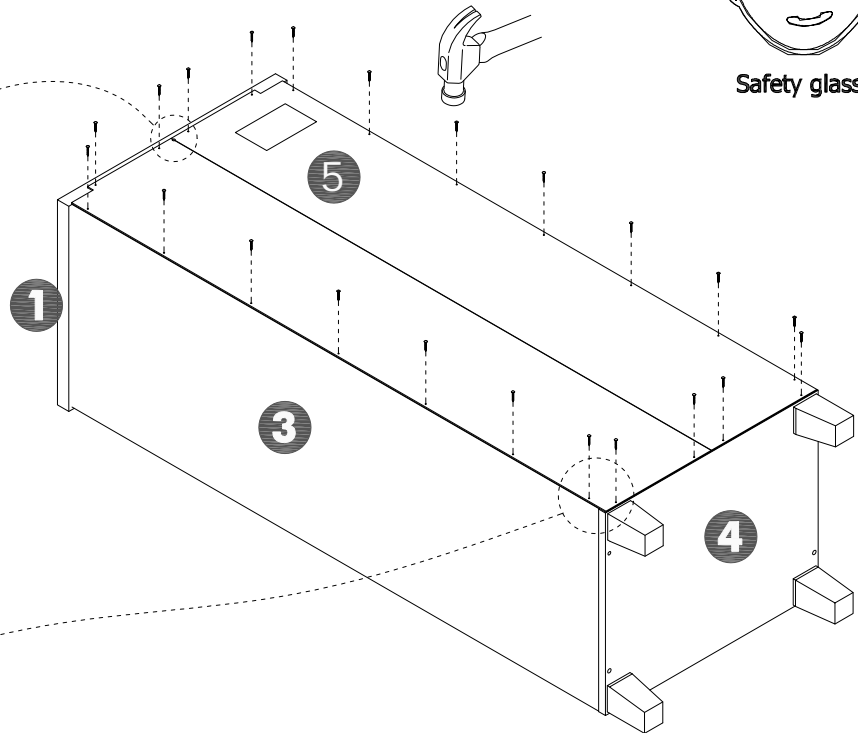
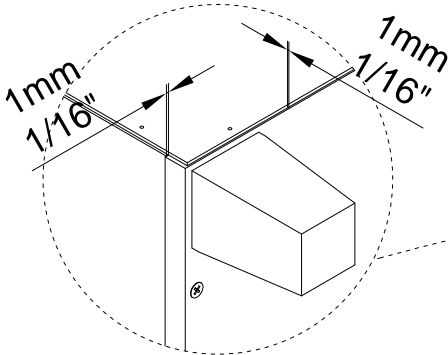

STEP 14

R x 4pcs 
5/6" nail

S x 2pcs 

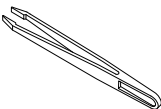
U 

U1 x 1pc 

U3 x 1pc 
Connecting Plate

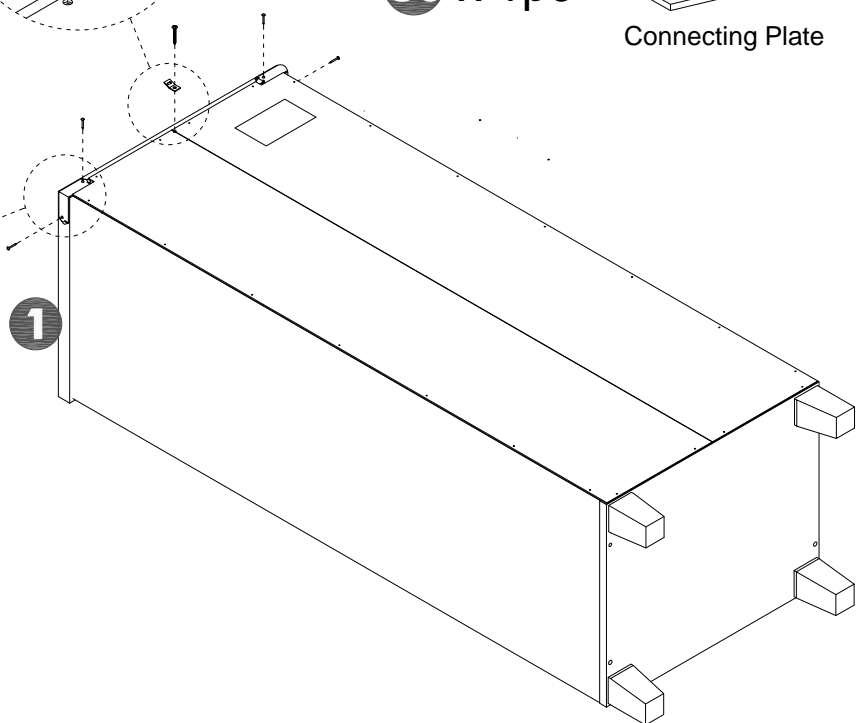
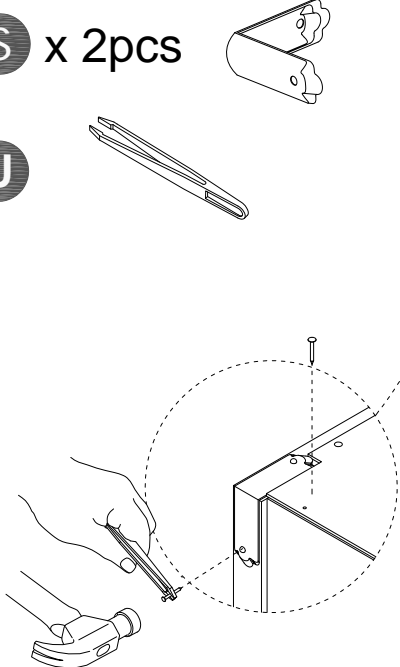
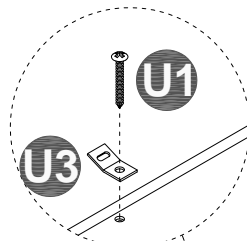

STEP 15

With assistant carefully flip unit over.

O x 18pcs 

Q x 2pcs 

P x 4pcs 

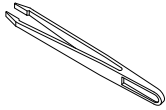
U 

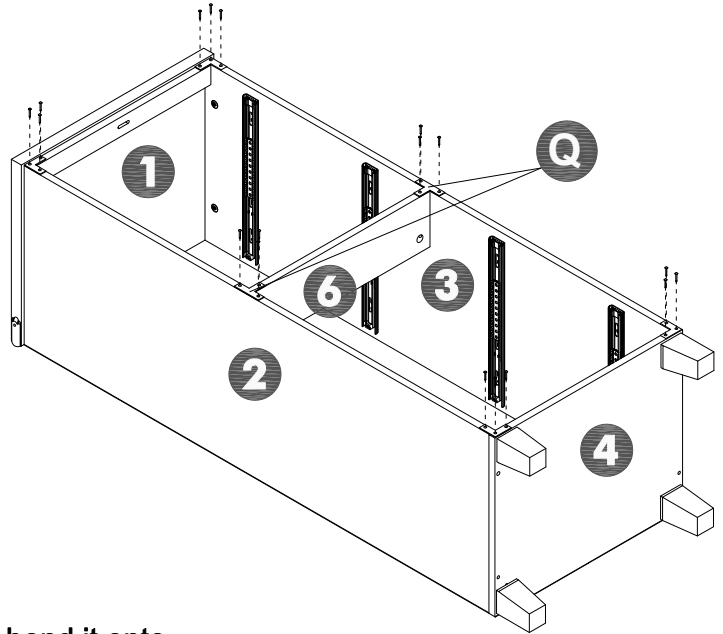
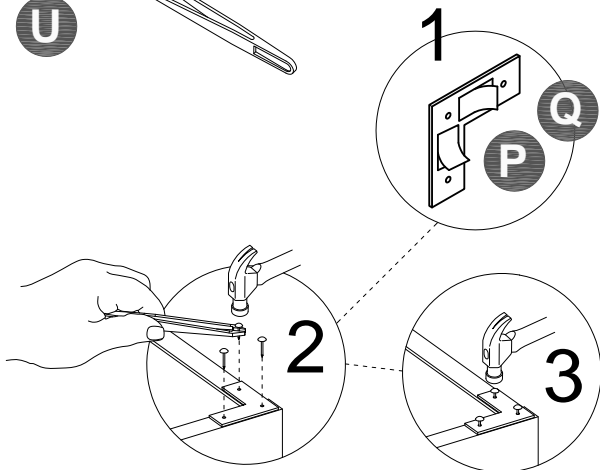

Peel off the adhesive sticker's protective paper and bond it onto the designated position before secure with nails.

STEP 16

R x 4pcs 
5/6" nail

S x 2pcs 

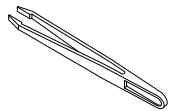
U 

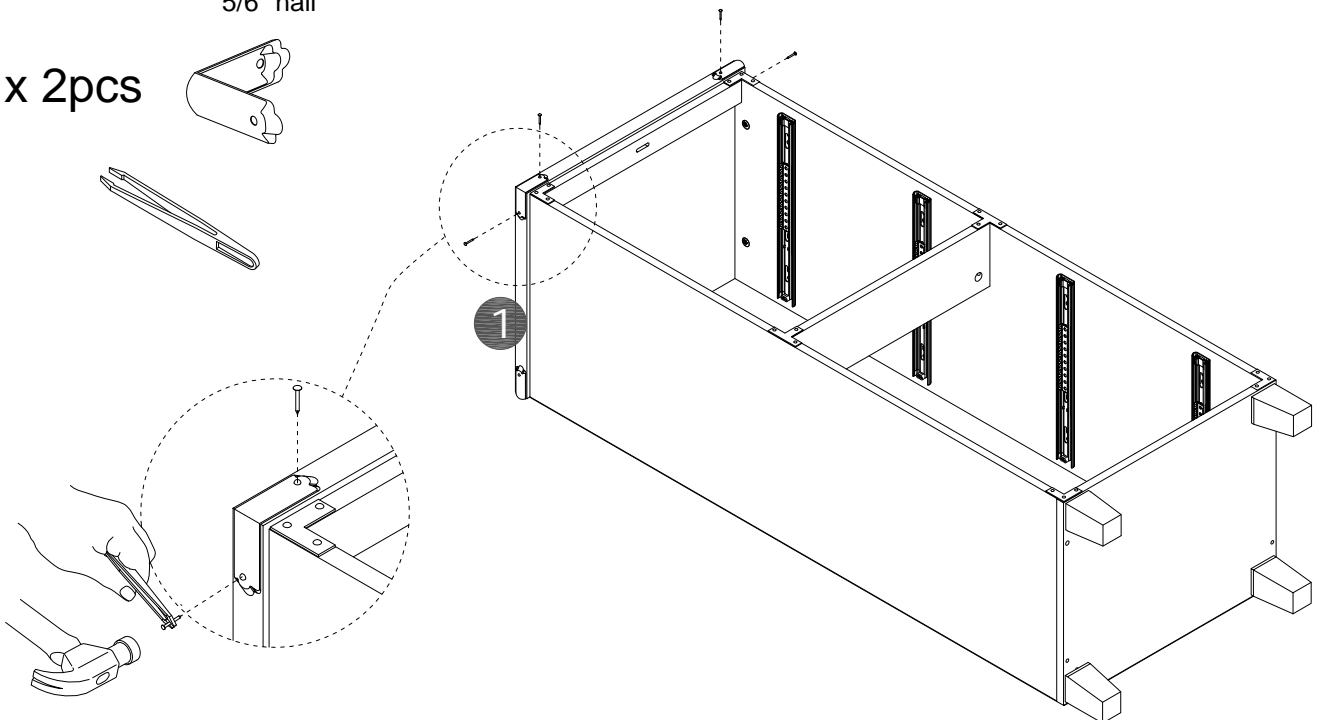

STEP 17

- Move unit to final location.
- Adjust drawer fronts as shown below.

Step1--Loosen screws on back of drawer front brackets as shown.

Step2--Position drawer front as required.

Step3--Tighten screws while holding drawer front in position.

DRAWER FRONT VIEW

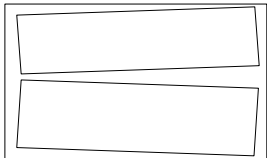
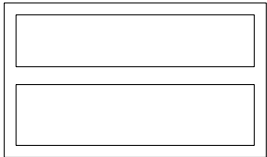

STEP 1.

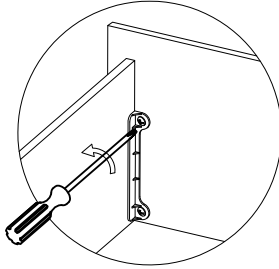

STEP 2.

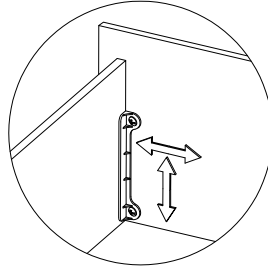

STEP 3.

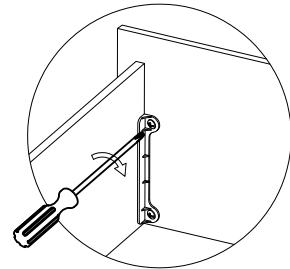

With assistant carefully stand unit up.

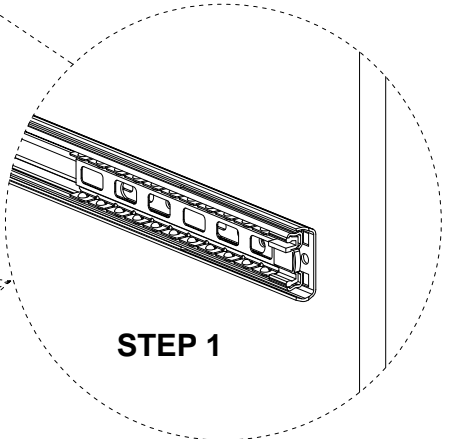
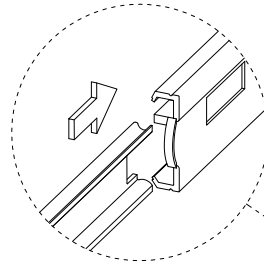

STEP 1

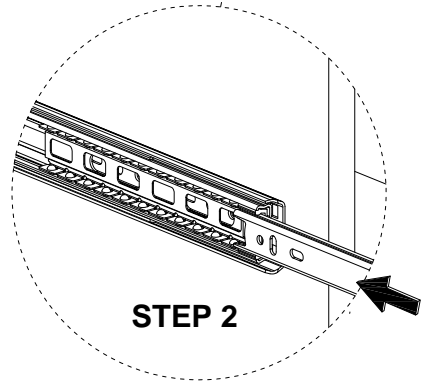

STEP 2

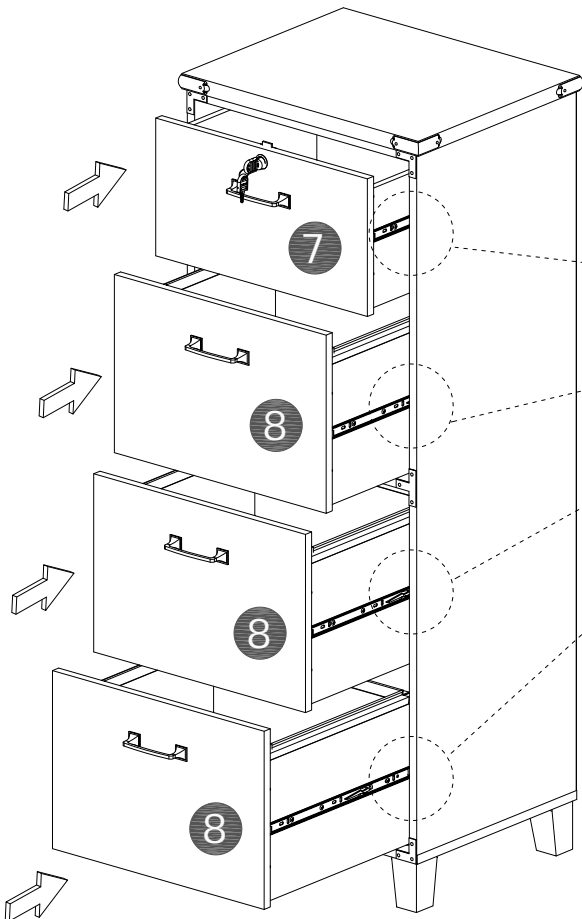

STEP 18

U₄ x 1pc

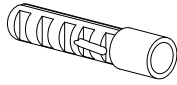

1. Place unit in desired location.
2. Mark stud location on the wall, 1" below top and side of unit.
3. Drill 5/16" hole 2" deep at marks on the wall.

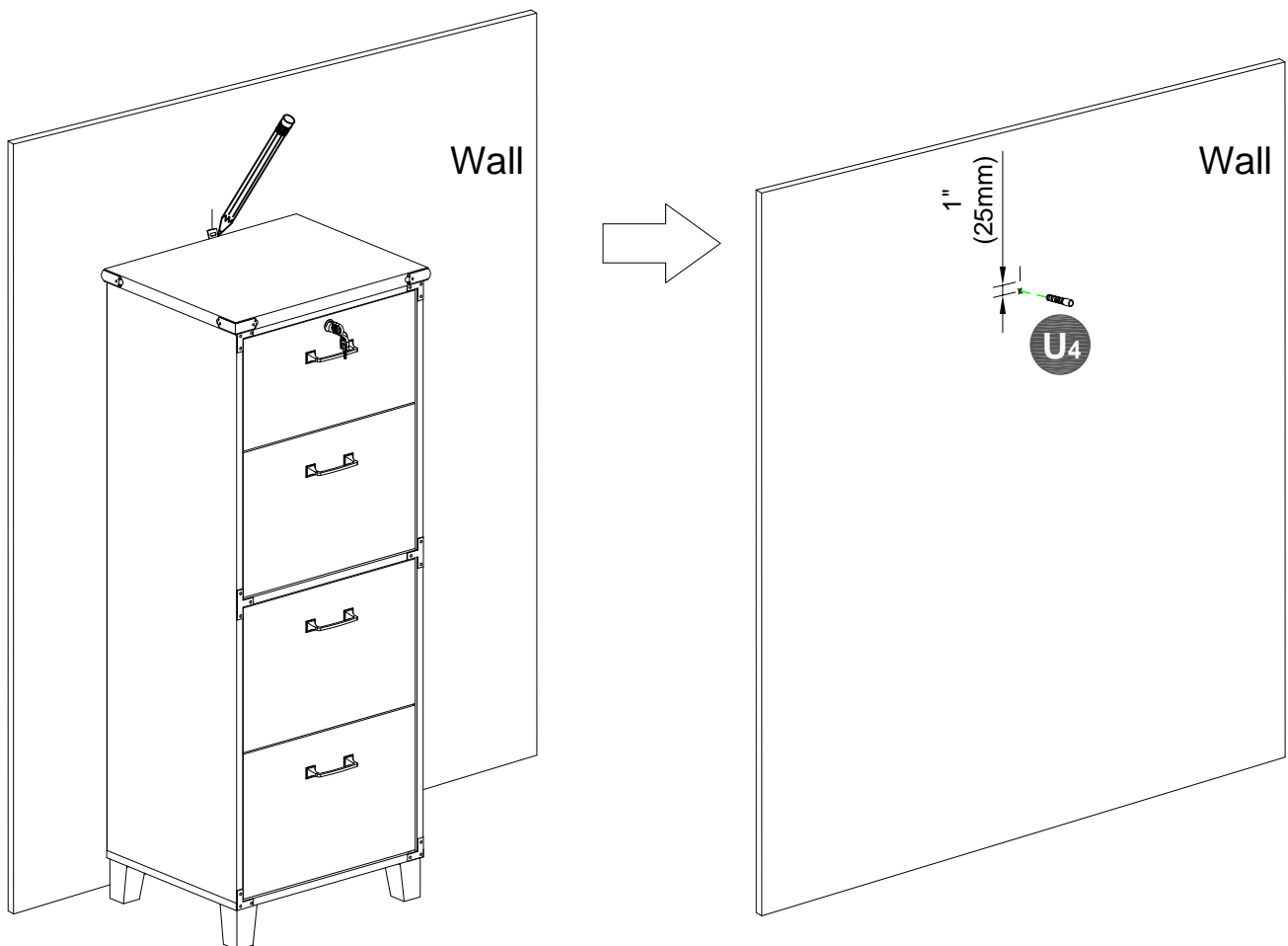
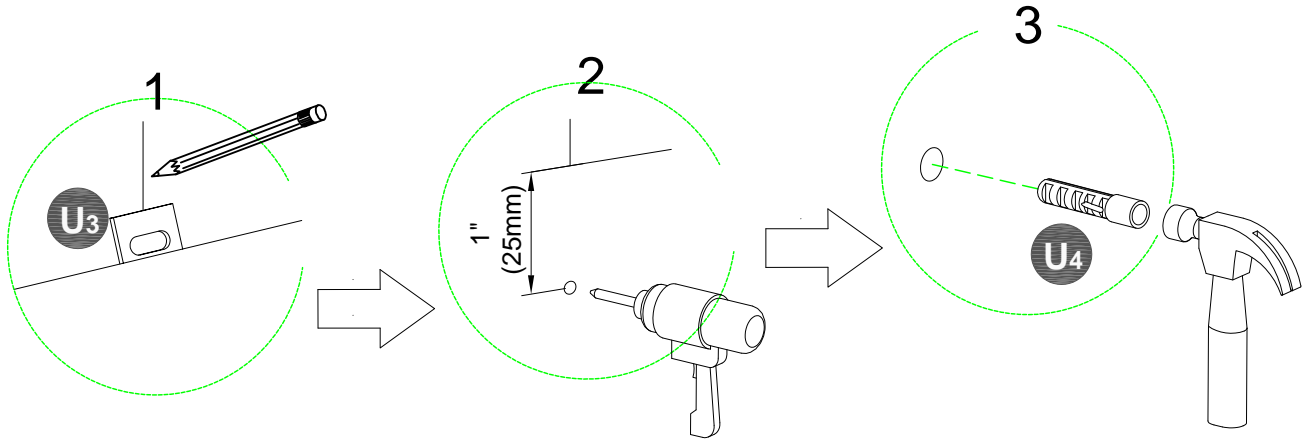

STEP 19

U₁ x 1pc

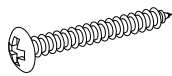

U₃ x 1pc

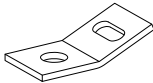

U₅ x 1pc

