

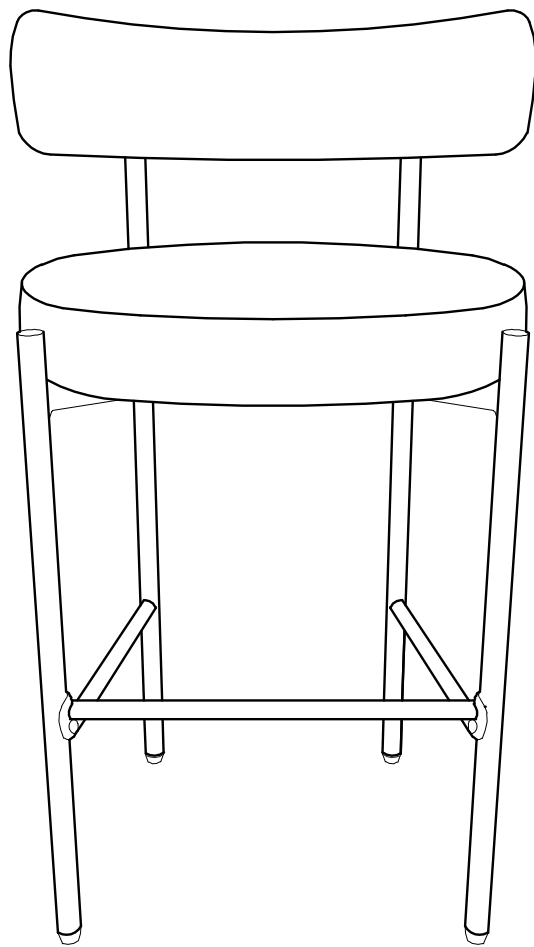

ASSEMBLY INSTRUCTIONS





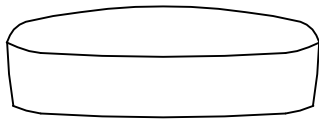
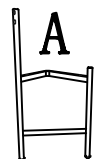
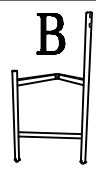
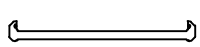

ASSEMBLY INSTRUCTIONS

Parts List

Label	Picture	Description	Qty
1		Chair Back	1
2		Chair Seat	1
3		Metal Leg	1
4		Metal Leg	1
5		Footrest Leg	1

Hardware

Label	Picture	Description	Qty
C	 M6*35MM	Screws	1
D	 M6*45MM	Screws	4
E	 M6*60MM	Screws	4
F	 M6*16MM	Screws	2
G	 M6	Allen Key	1

ASSEMBLY INSTRUCTIONS

Step 1:

Before assembly, please remove the protective caps from the chair.

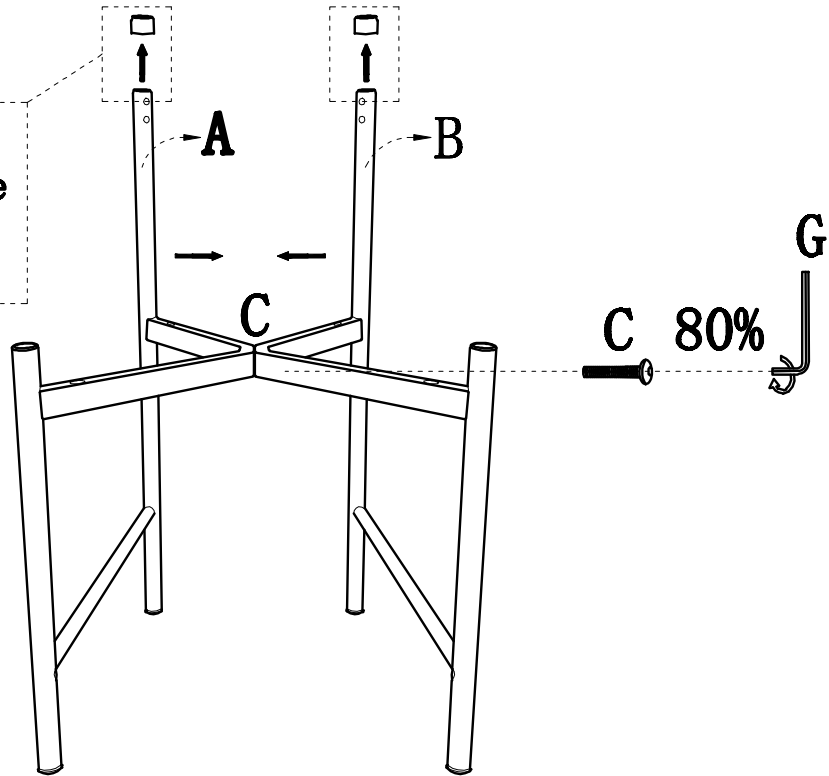

Do not fully tighten at this stage.

Step 2:

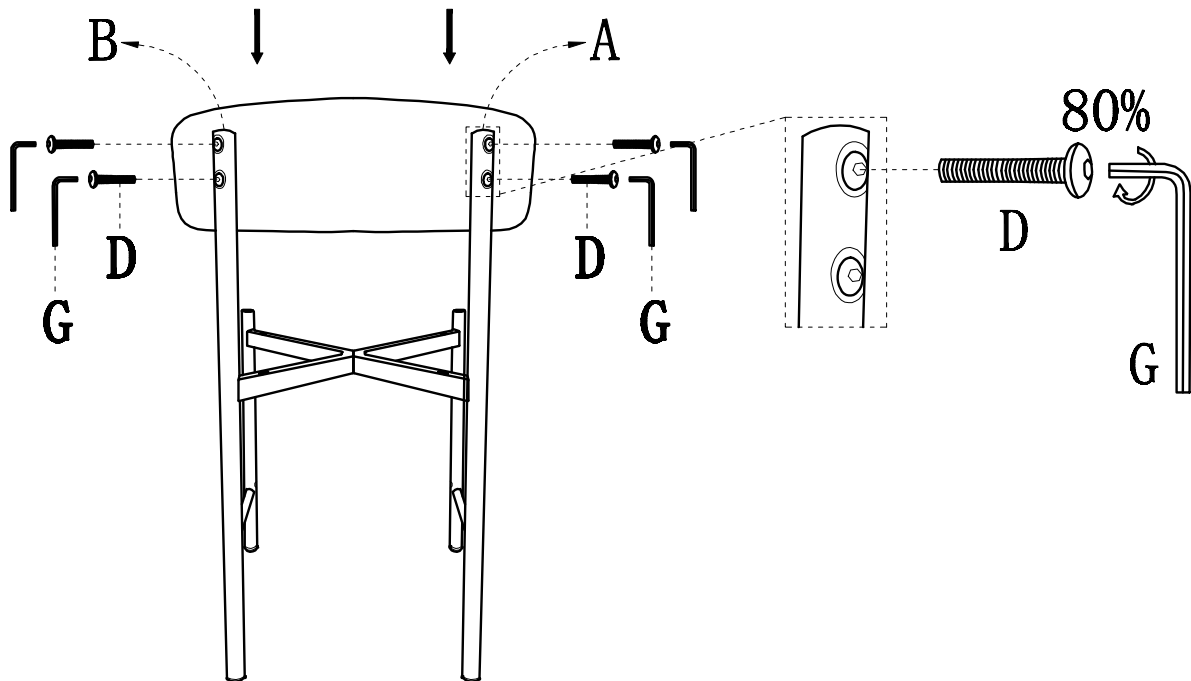

Do not fully tighten at this stage.

Back View

ASSEMBLY INSTRUCTIONS

Step 3:

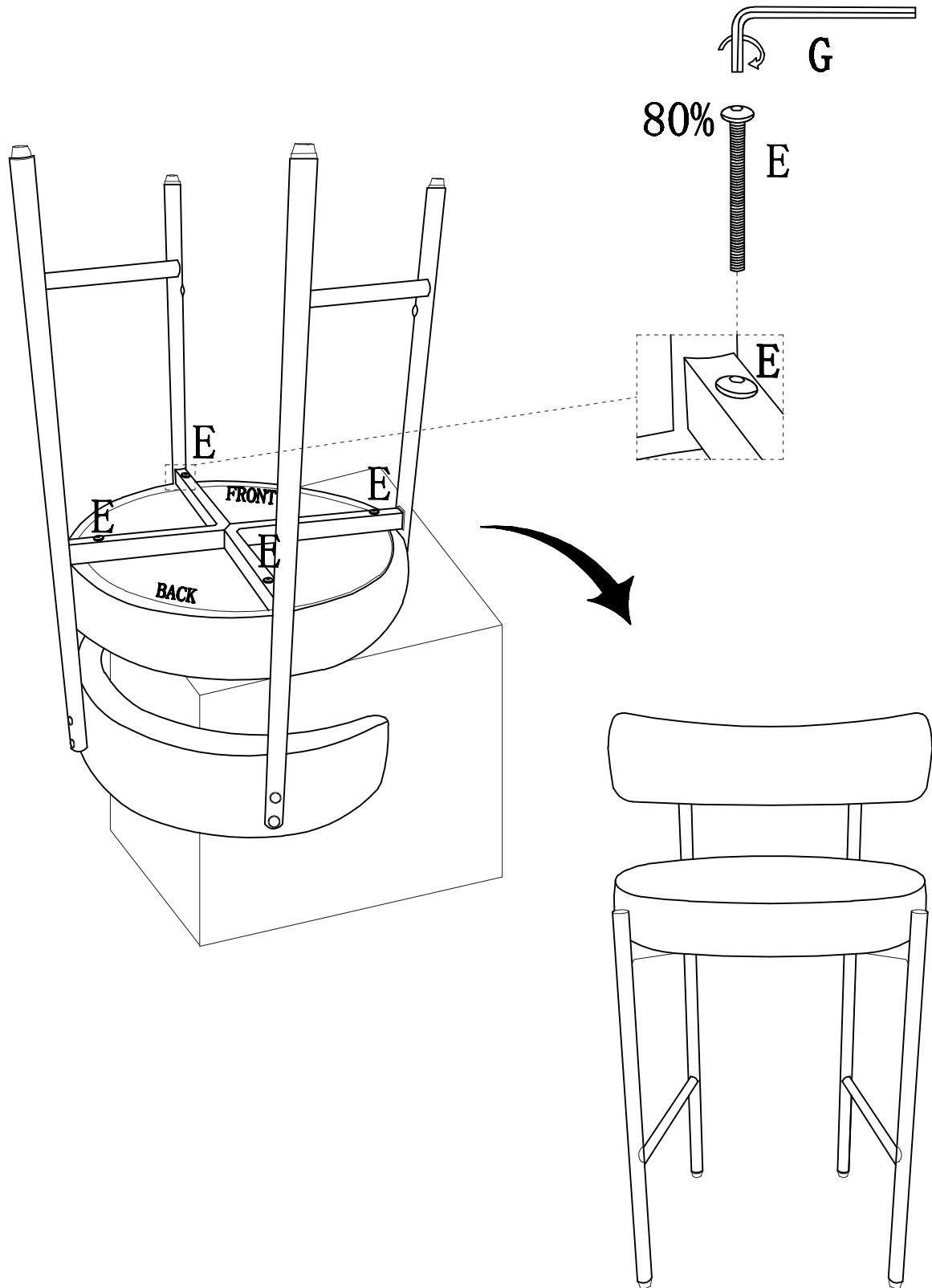

Do not fully tighten at this stage.

ASSEMBLY INSTRUCTIONS

Step 4:

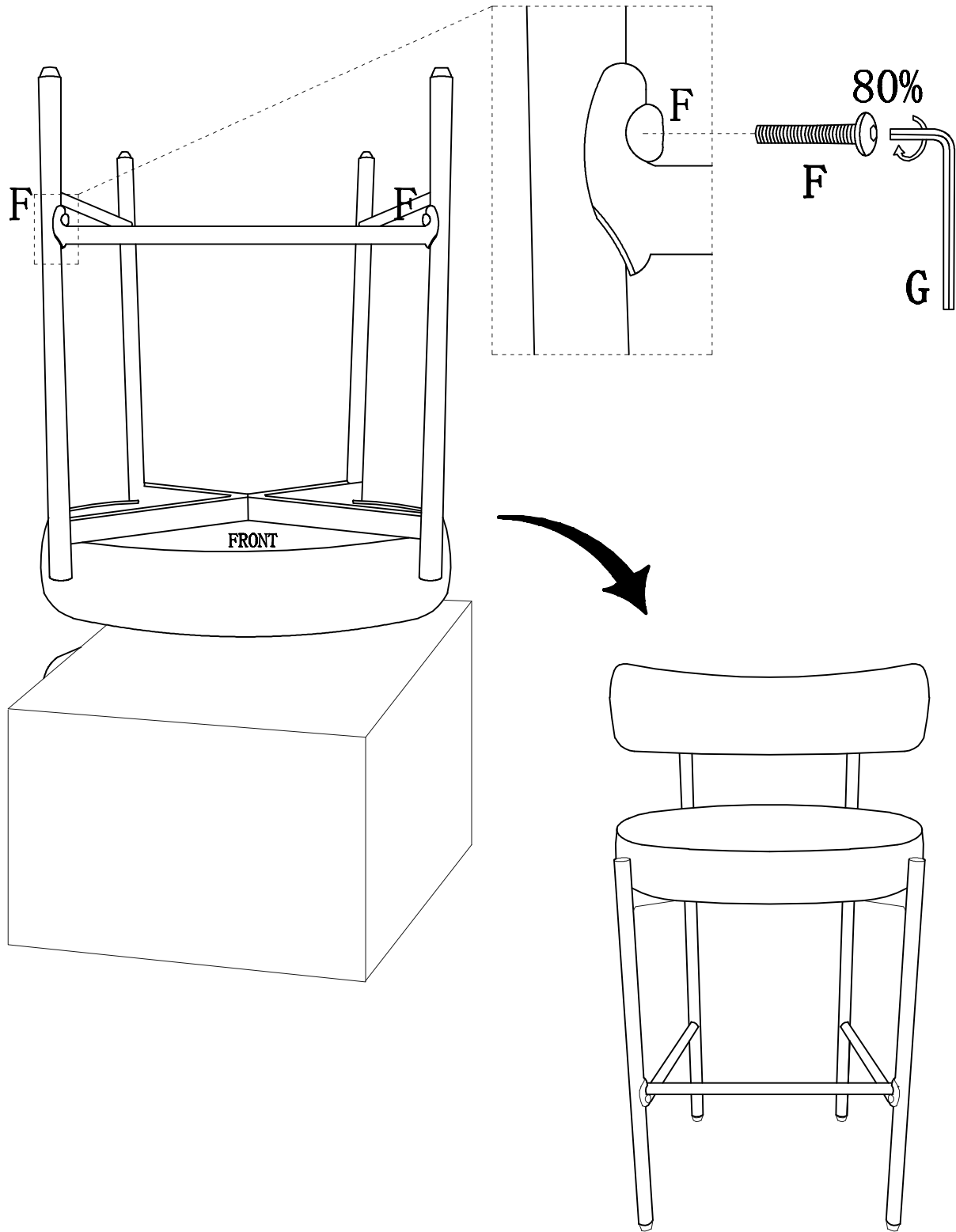

Do not fully tighten at this stage.

ASSEMBLY INSTRUCTIONS

Step 5:

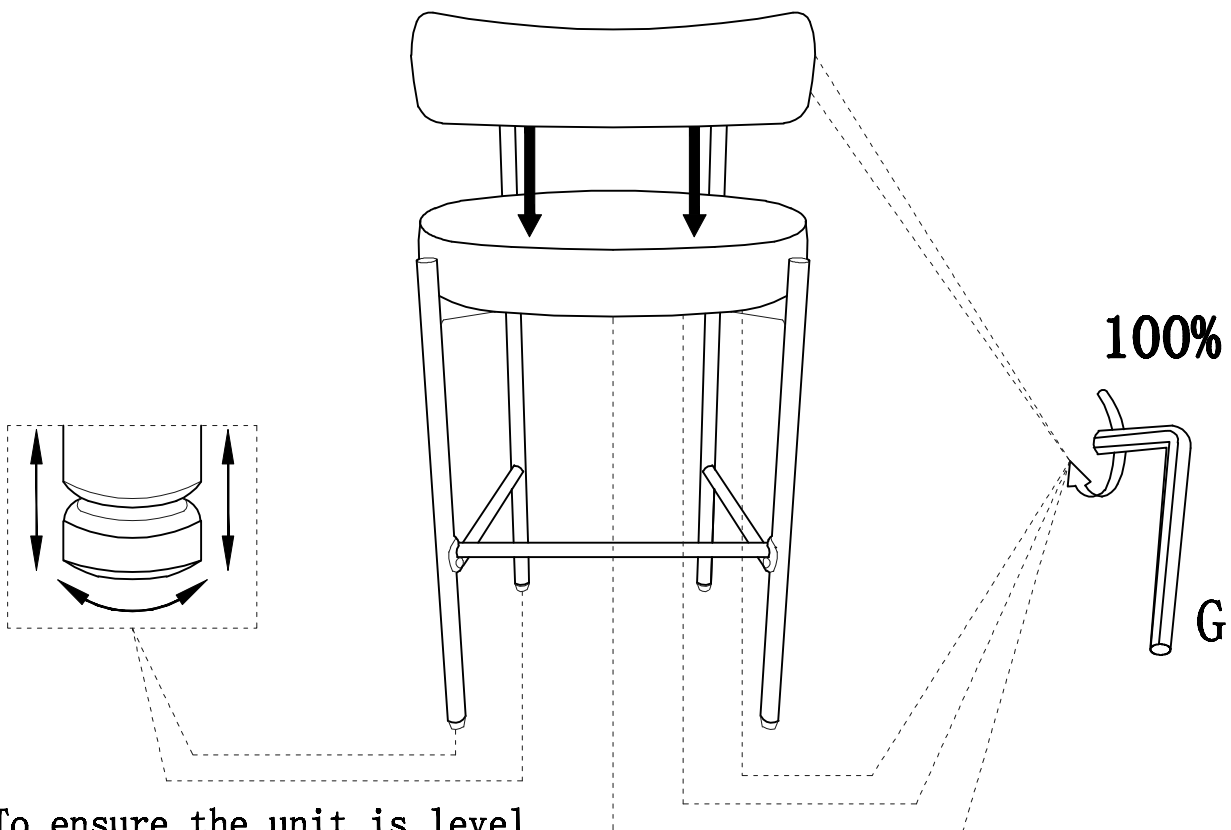
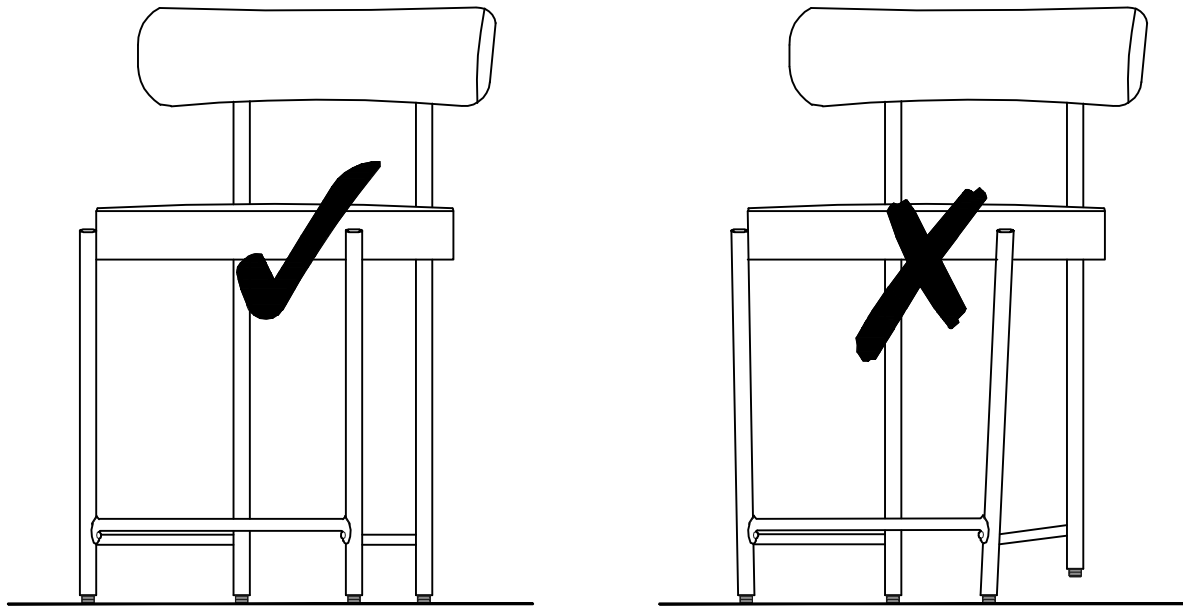

To ensure the unit is level on the floor please use the adjustable leveller.



Ensure all fittings are fully tightened before use.