

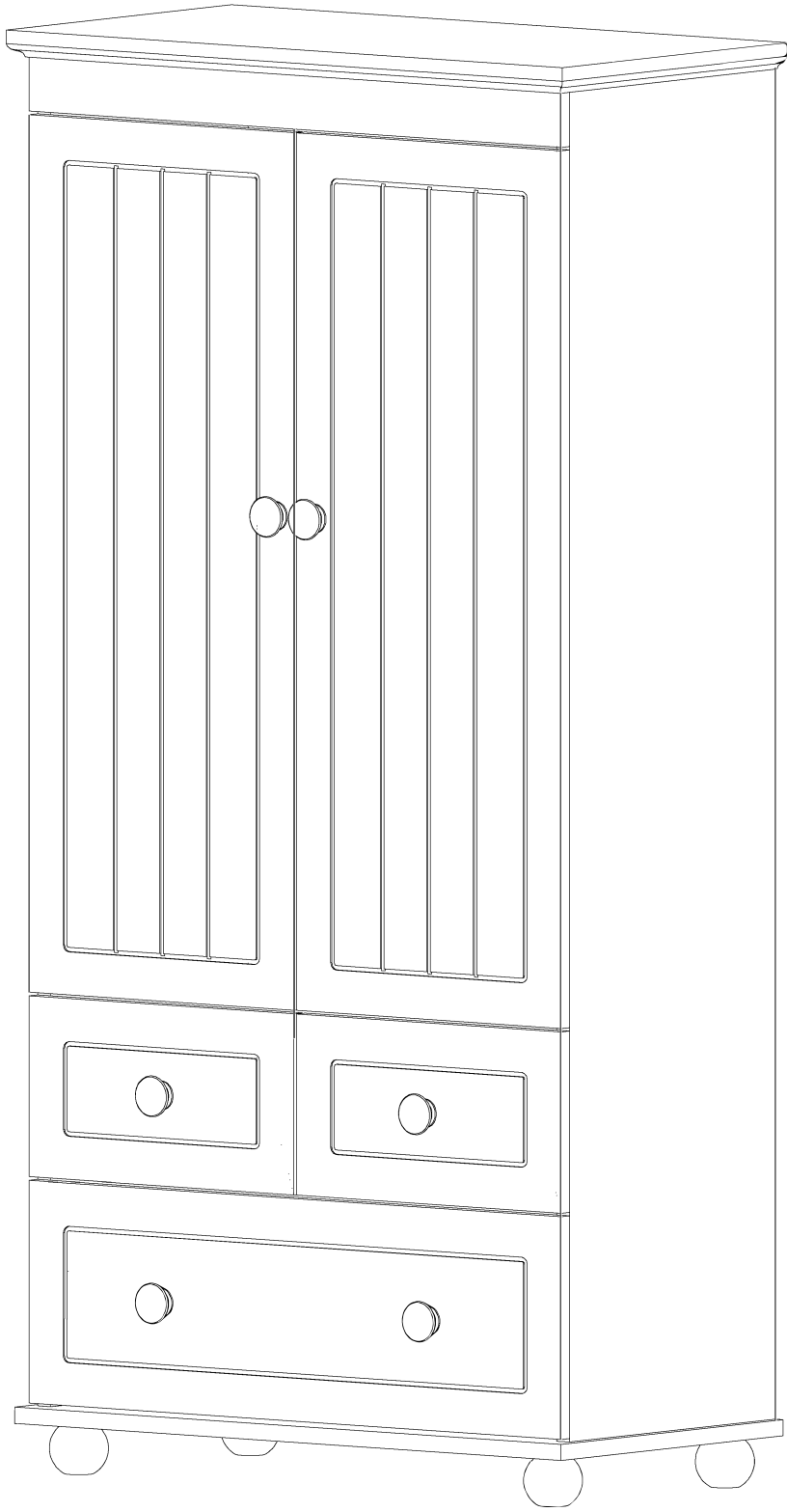

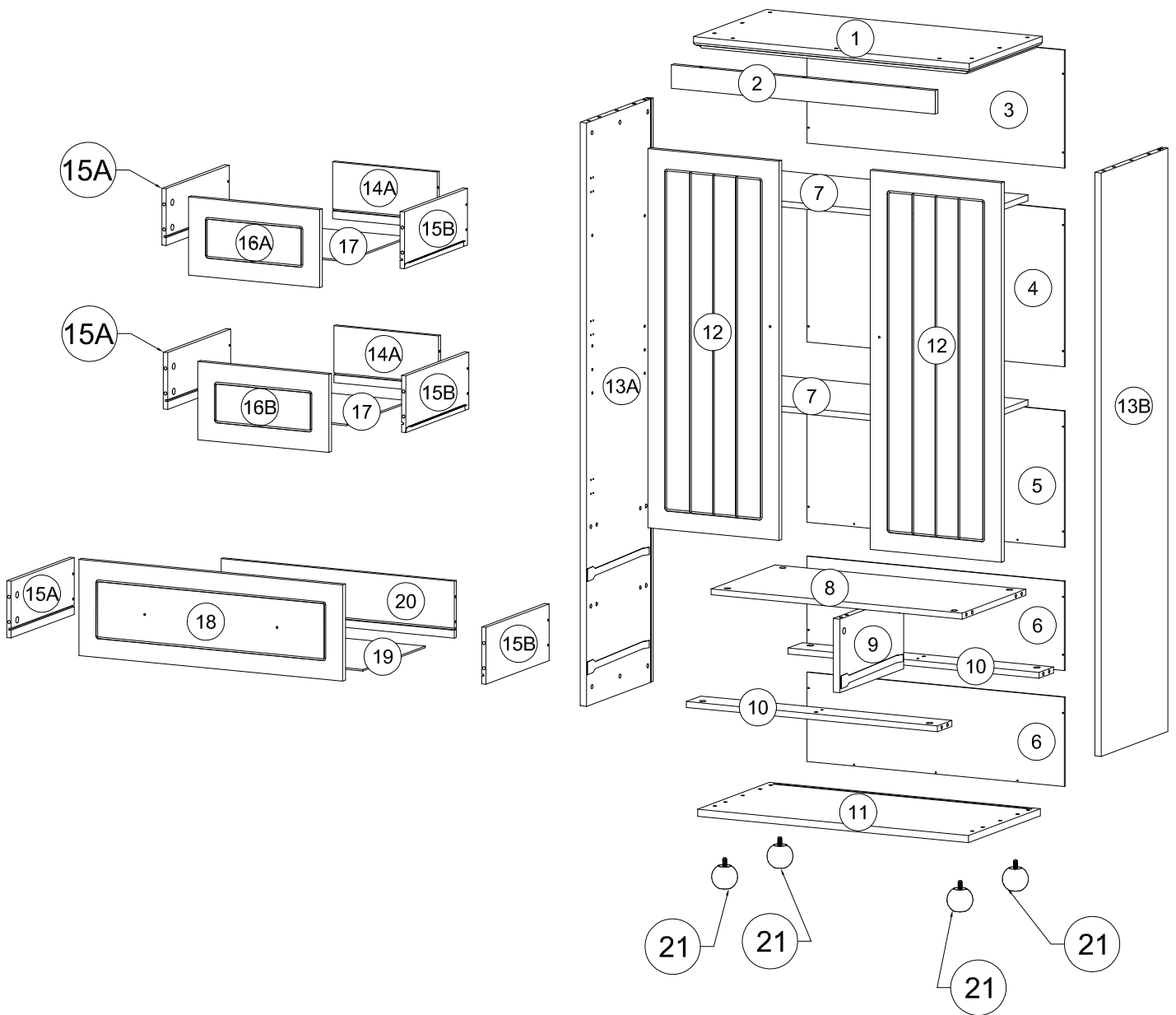



ASSEMBLY INSTRUCTION

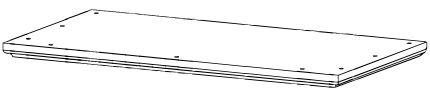

ASSEMBLY INSTRUCTION

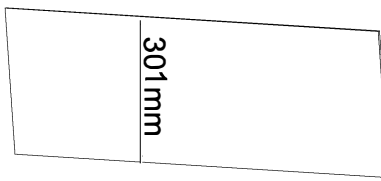
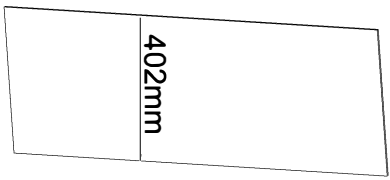
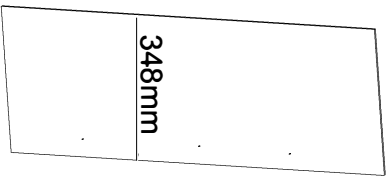
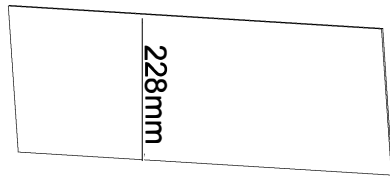
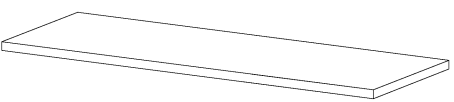
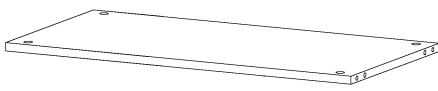
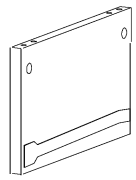
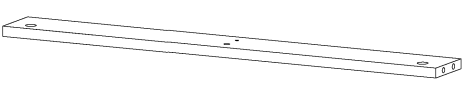

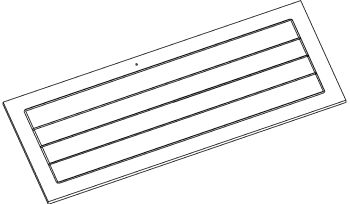
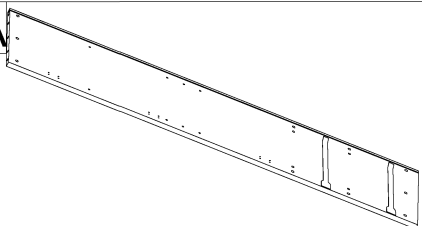
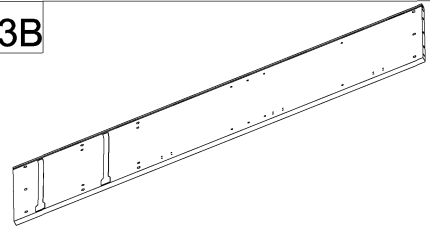
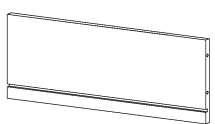
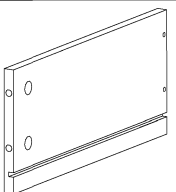
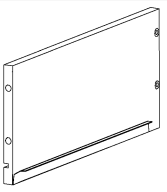
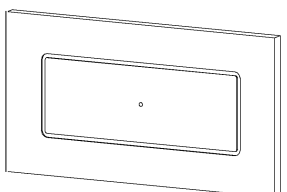
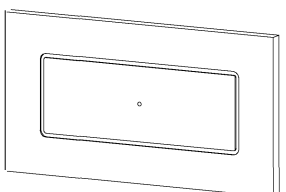
Part List

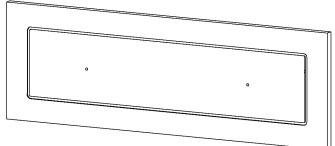
<p>1</p>  <p>The top of the cabinet-1pc</p>	<p>2</p>  <p>Short bar - 1pc</p>	<p>3</p>  <p>Cabinet Back-1pc</p>
<p>4</p>  <p>Cabinet Back-1pc</p>	<p>5</p>  <p>Cabinet Back-1pc</p>	<p>6</p>  <p>Cabinet Back-2pcs</p>
<p>7</p>  <p>MOVING SHELVES-2pcs</p>	<p>8</p>  <p>FIXED SHELF-1pc</p>	<p>9</p>  <p>vertical bar-1pc</p>
<p>10</p>  <p>Short bar - 2pcs</p>	<p>11</p>  <p>CABINET BOTTOM-1pc</p>	<p>12</p>  <p>CABINET WINGS-2pcs</p>
<p>13A</p>  <p>SIDE EDGE OF CABINET-1pc</p>	<p>13B</p>  <p>SIDE EDGE OF CABINET-1pc</p>	<p>14A</p>  <p>DRAWER-Back Panels-2pcs</p>
<p>15A</p>  <p>DRAWER-SIDE Panels-3pcs</p>	<p>15B</p>  <p>DRAWER-SIDE Panes-3pcs</p>	<p>16A</p>  <p>DRAWER-FRONT Panels-1pcs</p>
<p>16B</p>  <p>DRAWER-FRONT Panels-1pcs</p>	<p>17</p>  <p>Panel- 2pcs</p>	<p>18</p>  <p>DRAWER-FRONT Panels-1pc</p>

Part List

19



Panel- 1pc

20

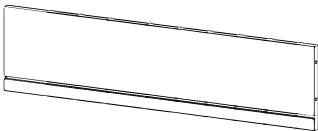









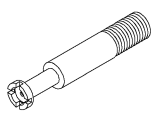

DRAWER-Back Panels-1pc

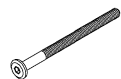
21

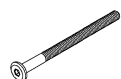
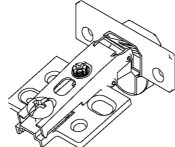

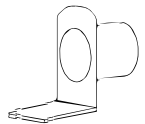
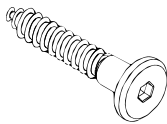
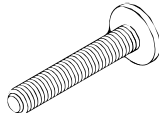
Legs-4pcs

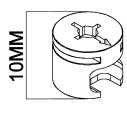
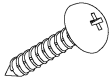
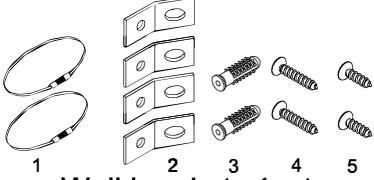

Hardware List

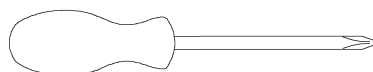
<p>A</p>  <p>Link 1 - 22 pcs</p>	<p>B</p>  <p>Link 2- 12mm - 2pcs</p>	<p>C</p>  <p>1/4" x 10mm Horizontal -Hole bolts 15pcs</p>
<p>D</p>  <p>1/4" x 60mm Hex-Head bolts 6pcs</p>	<p>E</p>  <p>Ø8 x 30 mm Wood dowel 22pcs</p>	<p>F</p>  <p>#4 x 15 mm Wood Screws 36pcs</p>
<p>G</p>  <p>1/4" x 70mm Hex-Head bolts 9pcs</p>	<p>H</p>  <p>Hinge - 6pcs</p>	<p>R</p>  <p>Handle 6pcs</p>
<p>J</p>  <p>Support Pin 8pcs</p>	<p>K</p>  <p>Ø1/4 x 30 mm wood screws 2pcs</p>	<p>L</p>  <p>M4 x 20mm Hex-Head bolts 6pcs</p>
<p>M</p>  <p>#4 x 30 mm Wood Screws 16pcs</p>	<p>N</p>  <p>Link 2 -10mm - 20 pcs</p>	<p>O</p>  <p>M4 x 20 mm Wood Screws 27pcs</p>
<p>P</p>  <p>Wall brackets 1set</p>	<p>Q</p>  <p>Allen Key 1pcs</p>	

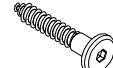
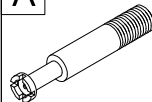

Assembly Tools Required (Not Included)

STEP 1: Following below illustration:

E 	K 	A 	B 
4pcs	2pcs	2pcs	2pcs

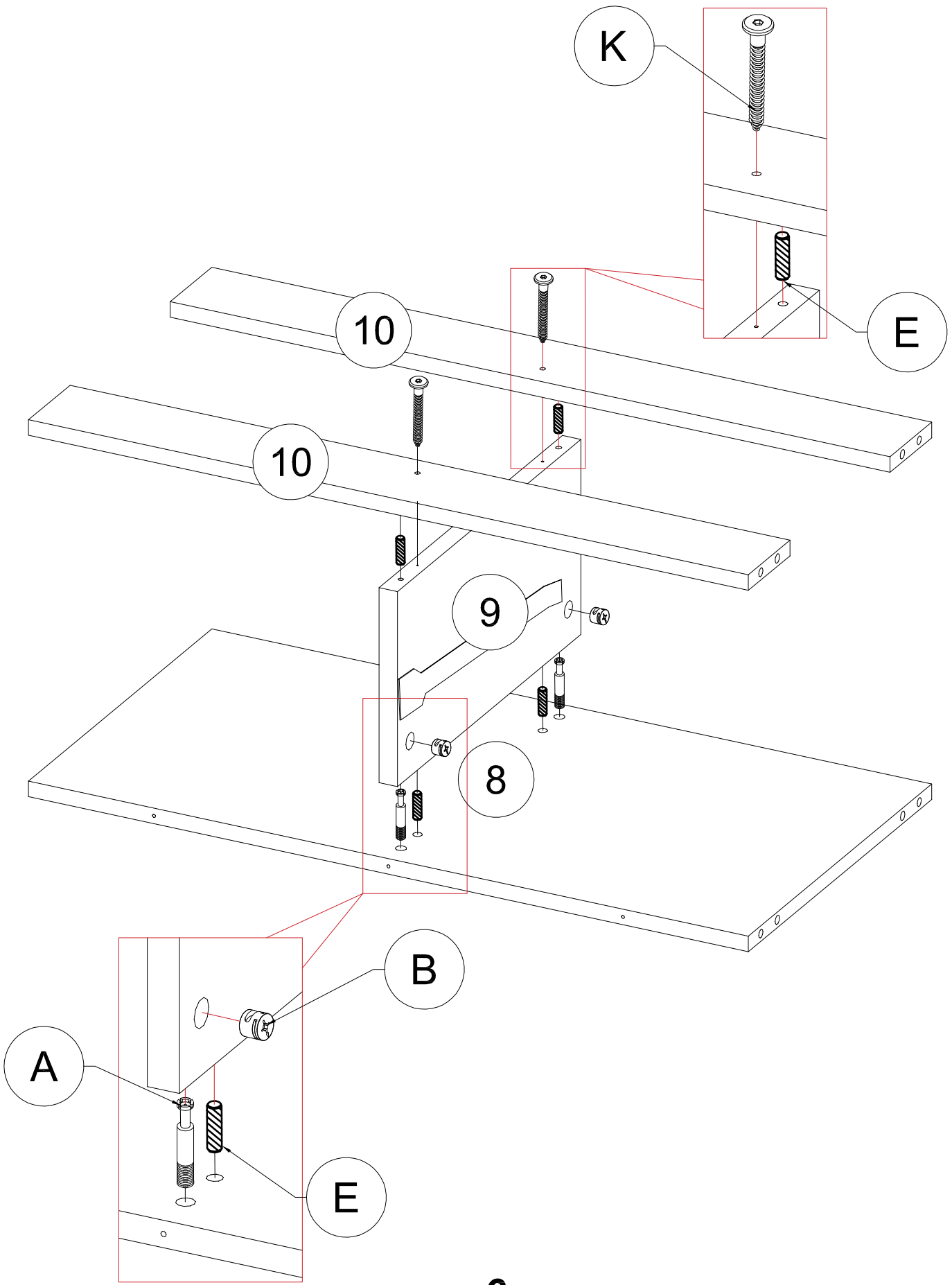



6

STEP 2: Following below illustration:

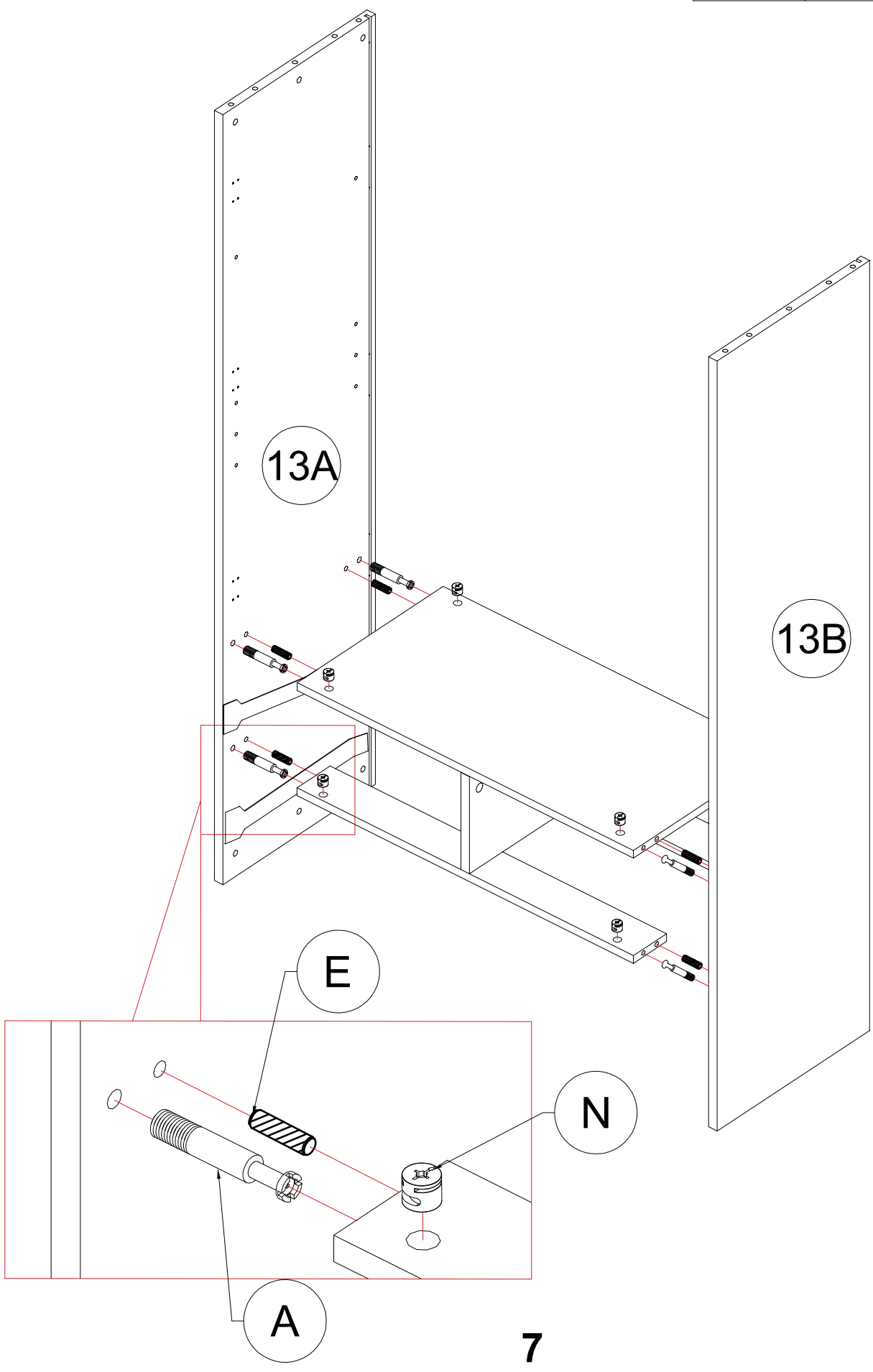
A	N	E
8pcs	8pcs	8pcs

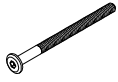

STEP 3: Following below illustration:

D	C	E
		
6pcs	6pcs	4pcs

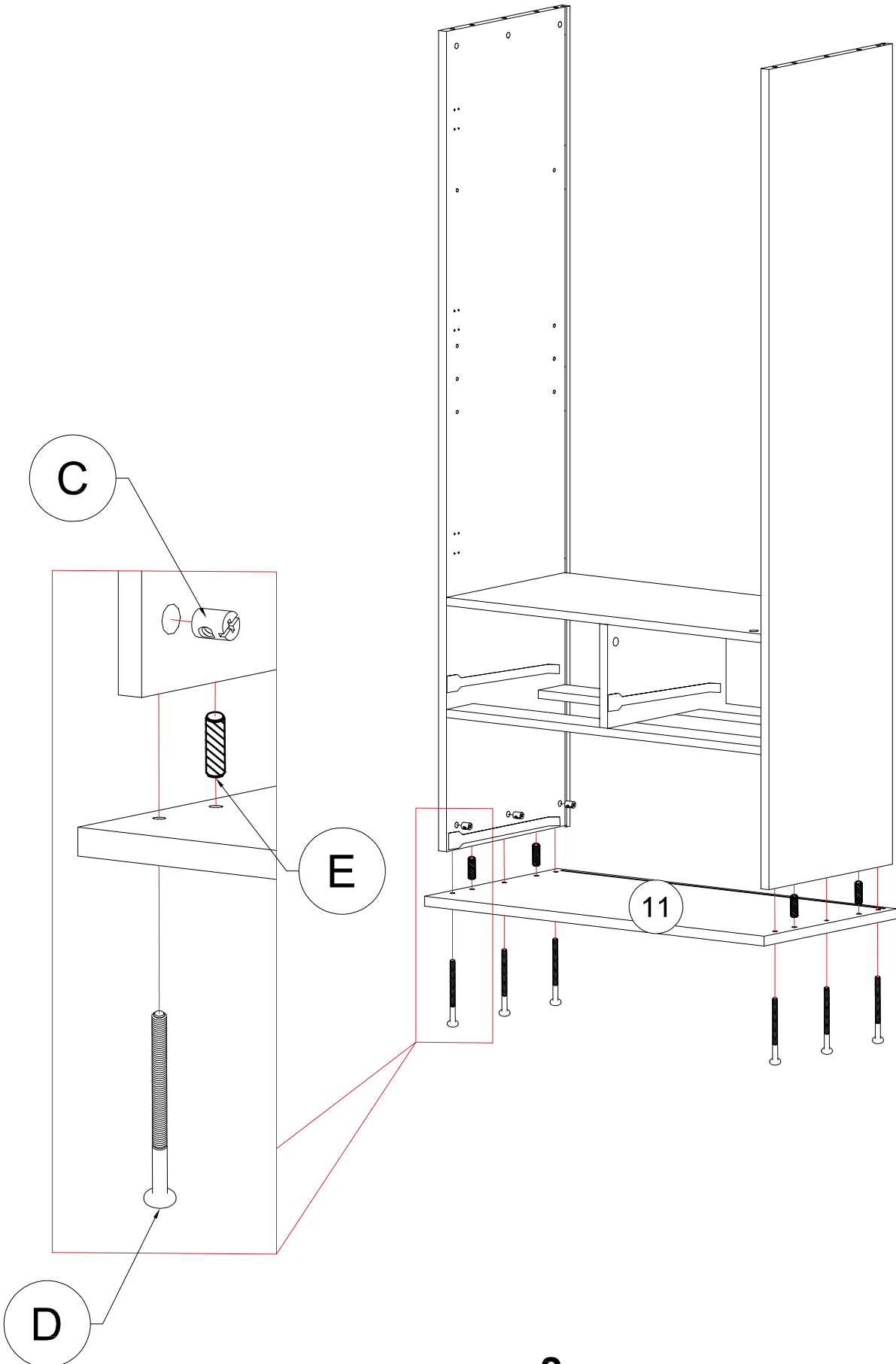

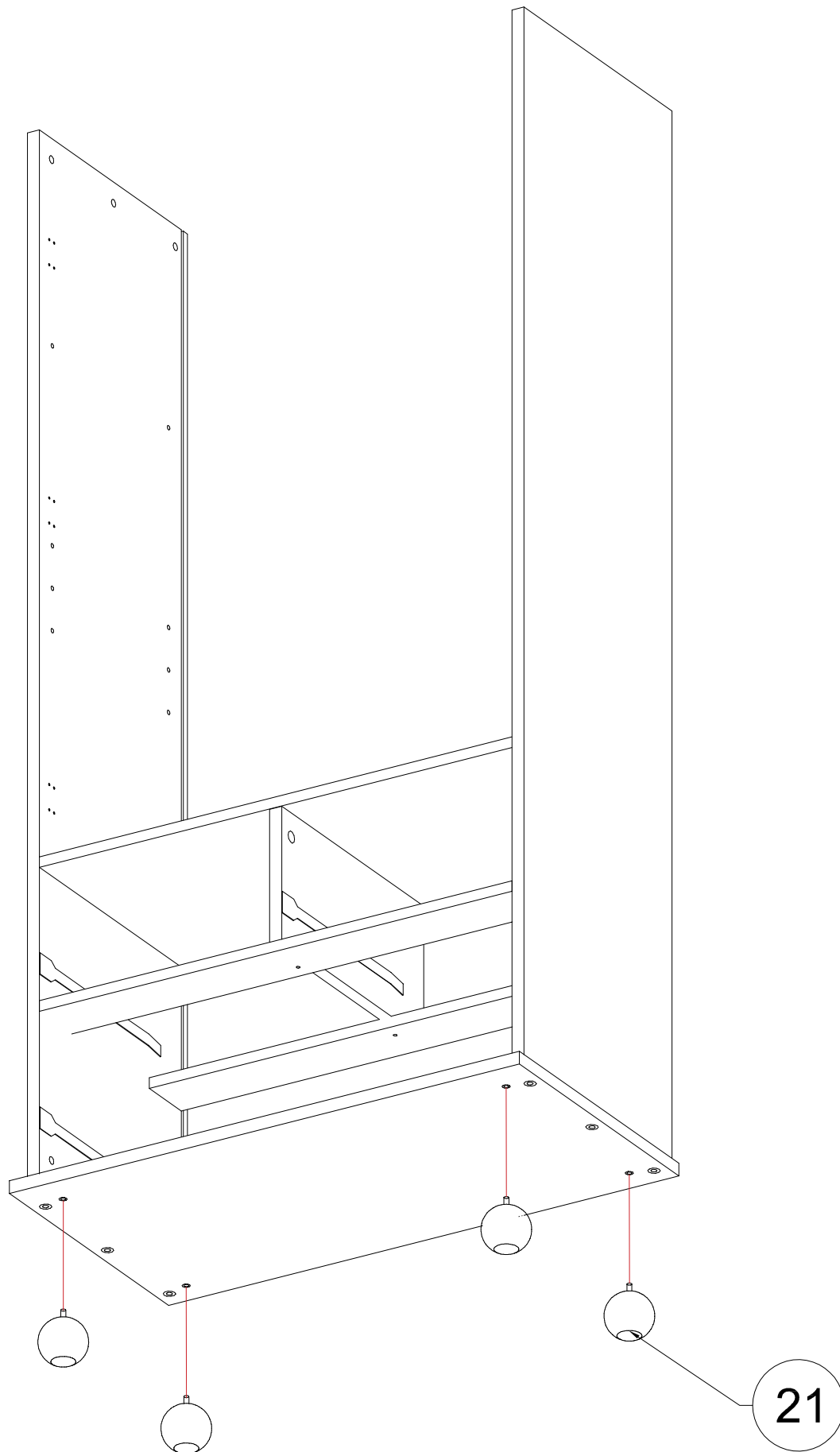

STEP 4: Following below illustration:

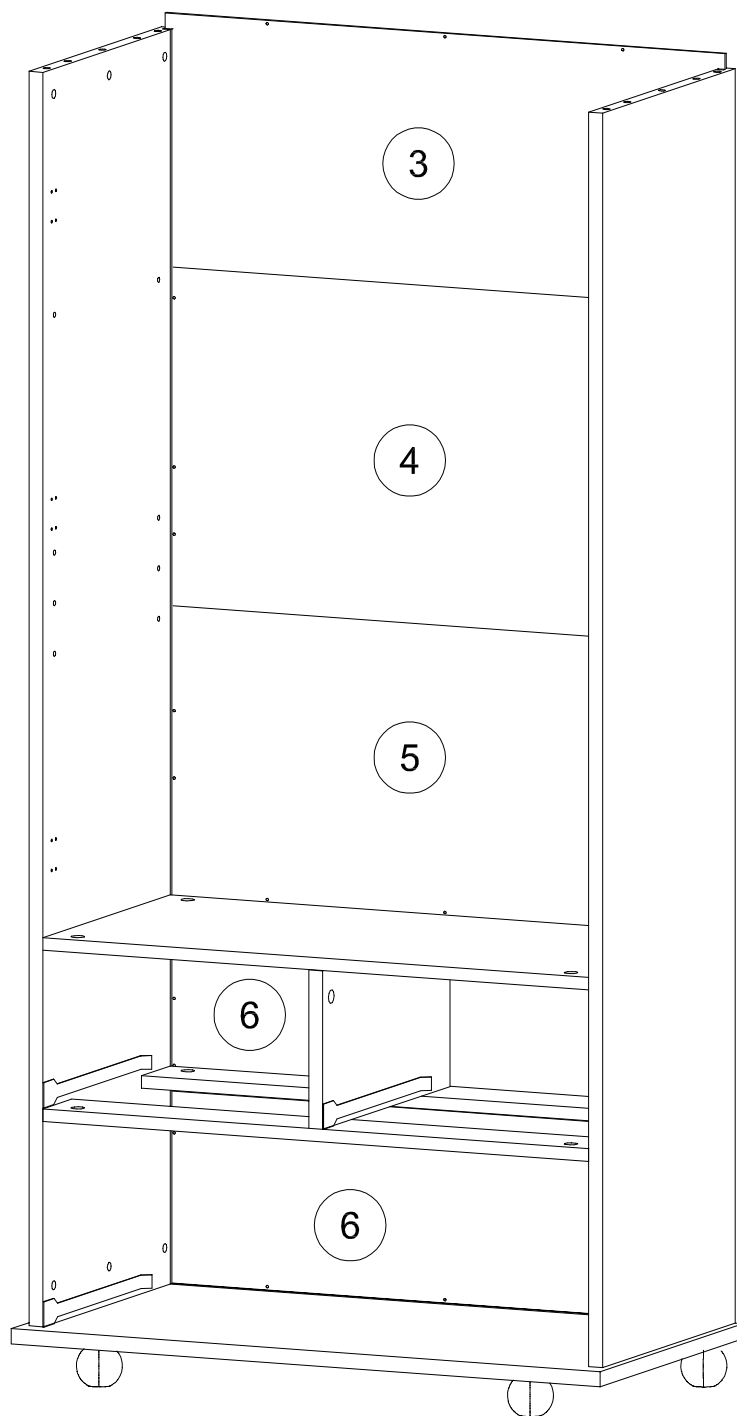
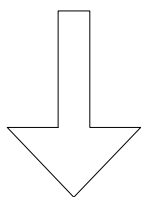

STEP 5: Following below illustration:



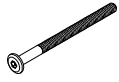

STEP 6: Following below illustration:

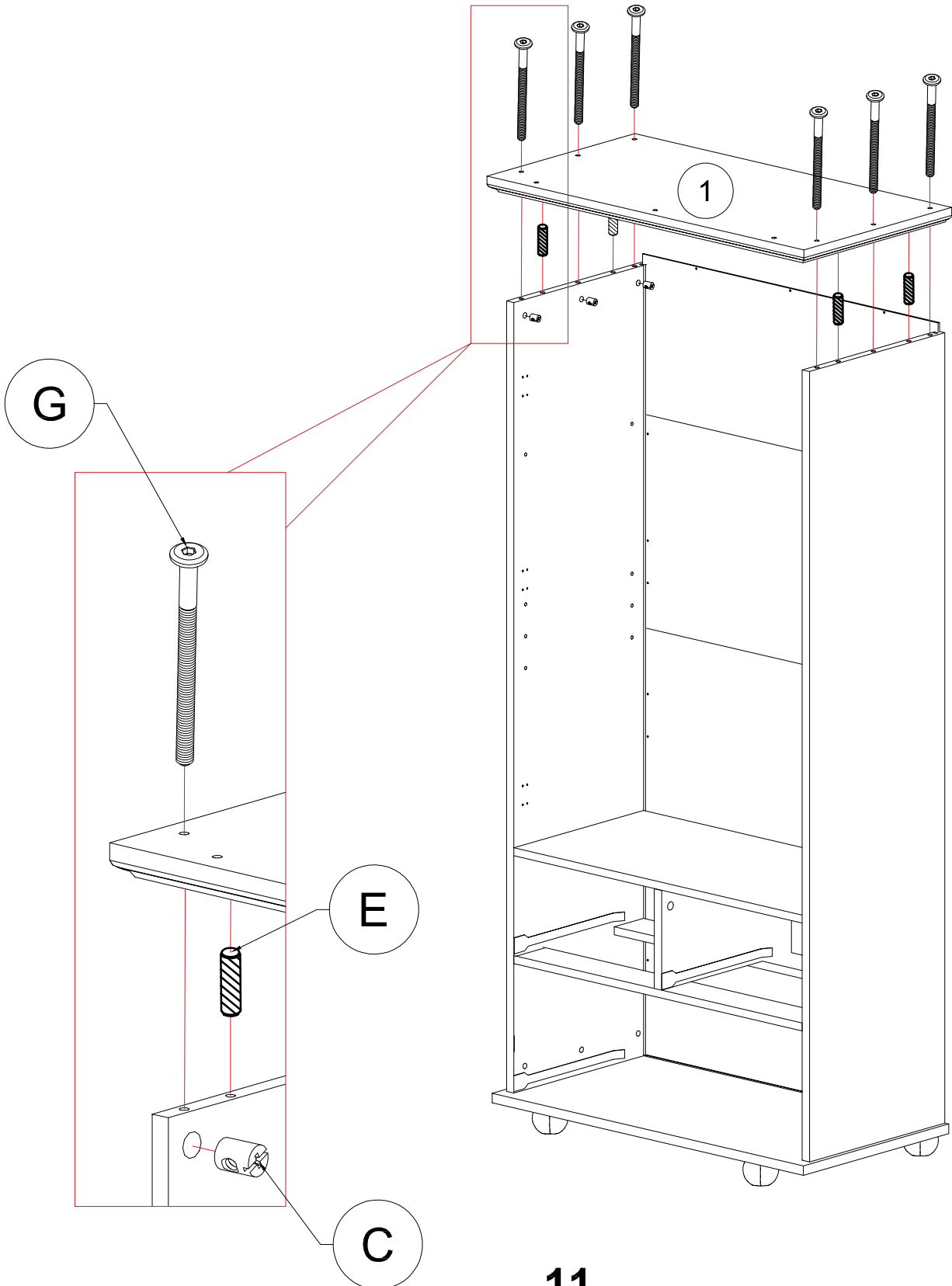
G 	C 	E 
6pcs	6pcs	4pcs



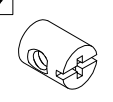

STEP 7: Following below illustration:

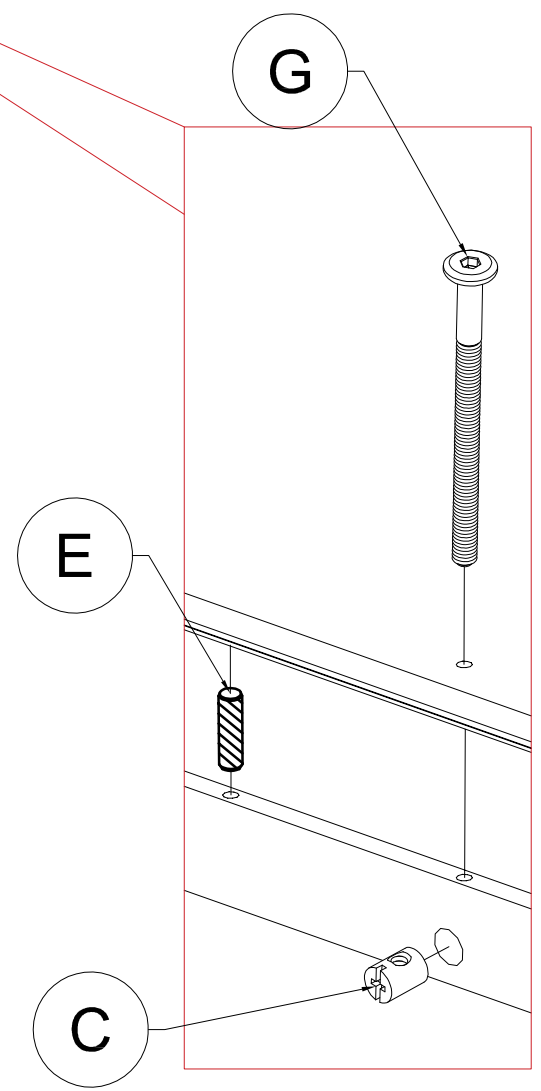
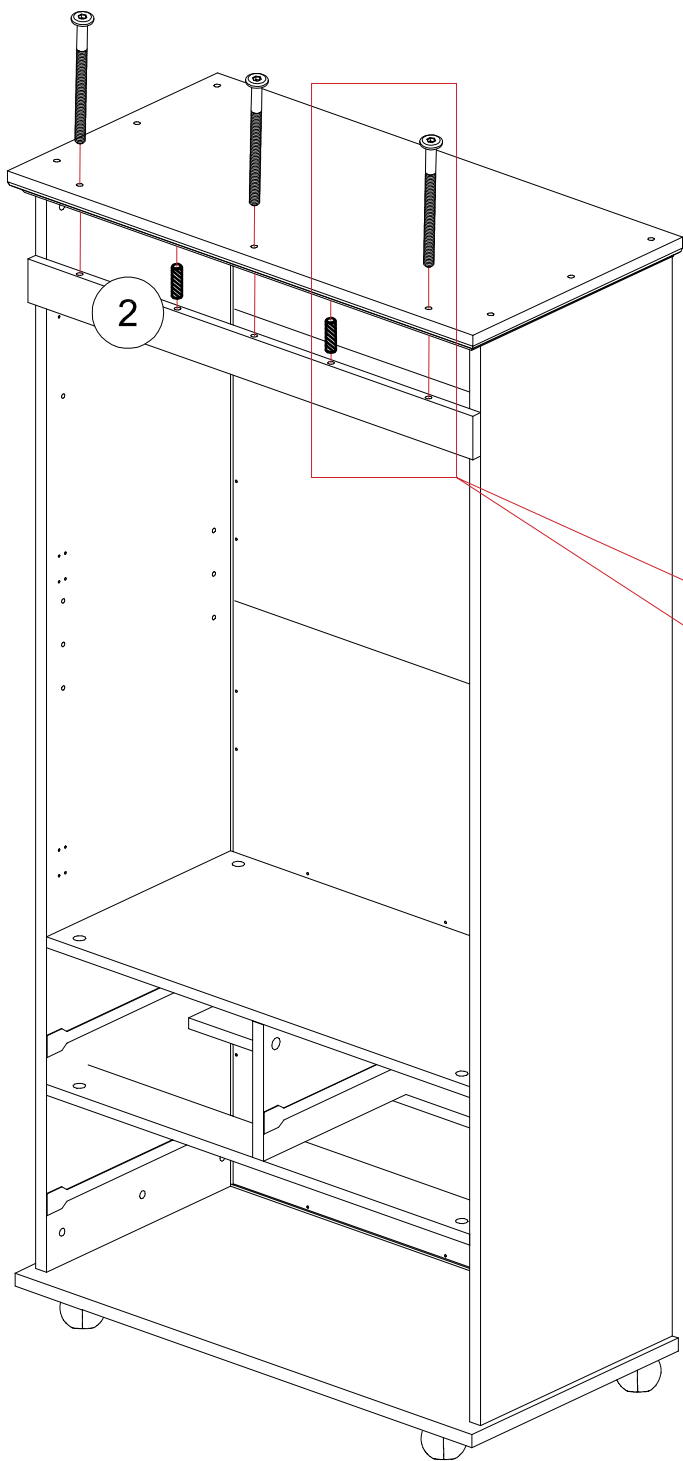
G		C		E	
	3pcs		3pcs		2pcs



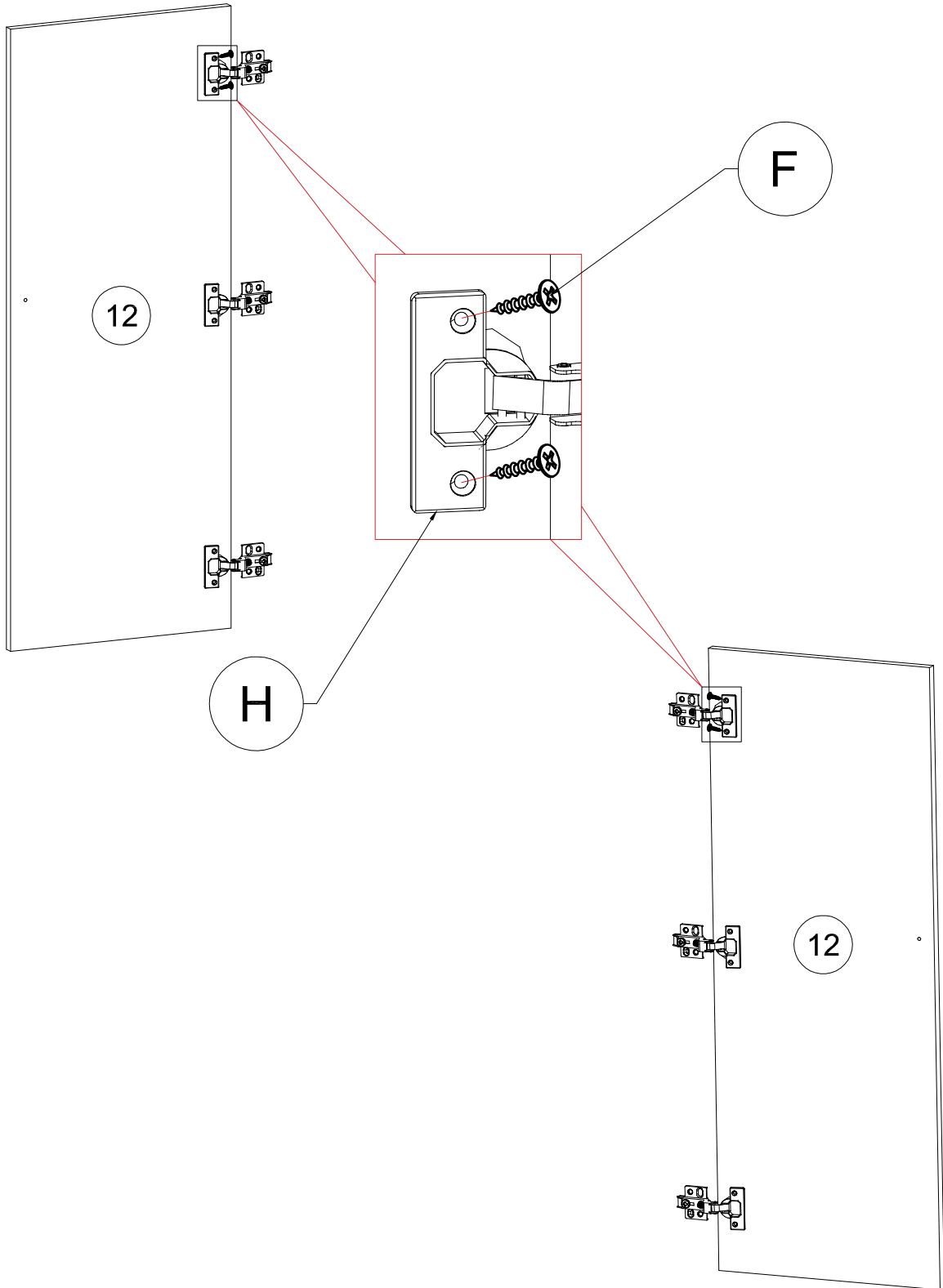

STEP 8: Following below illustration:

H 	F 
6pcs	12pcs

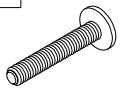

STEP 9: Following below illustration:

R	L	F
		
2pcs	2pcs	24pcs

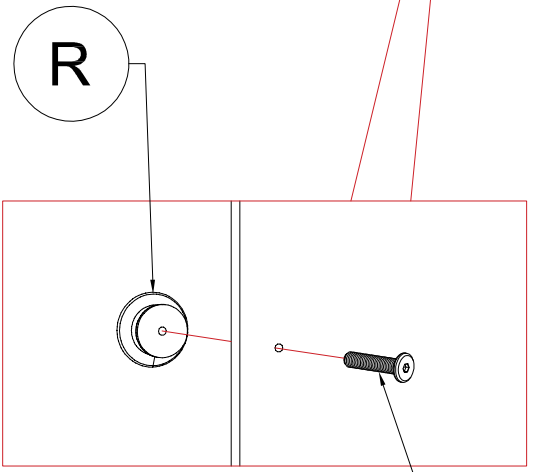
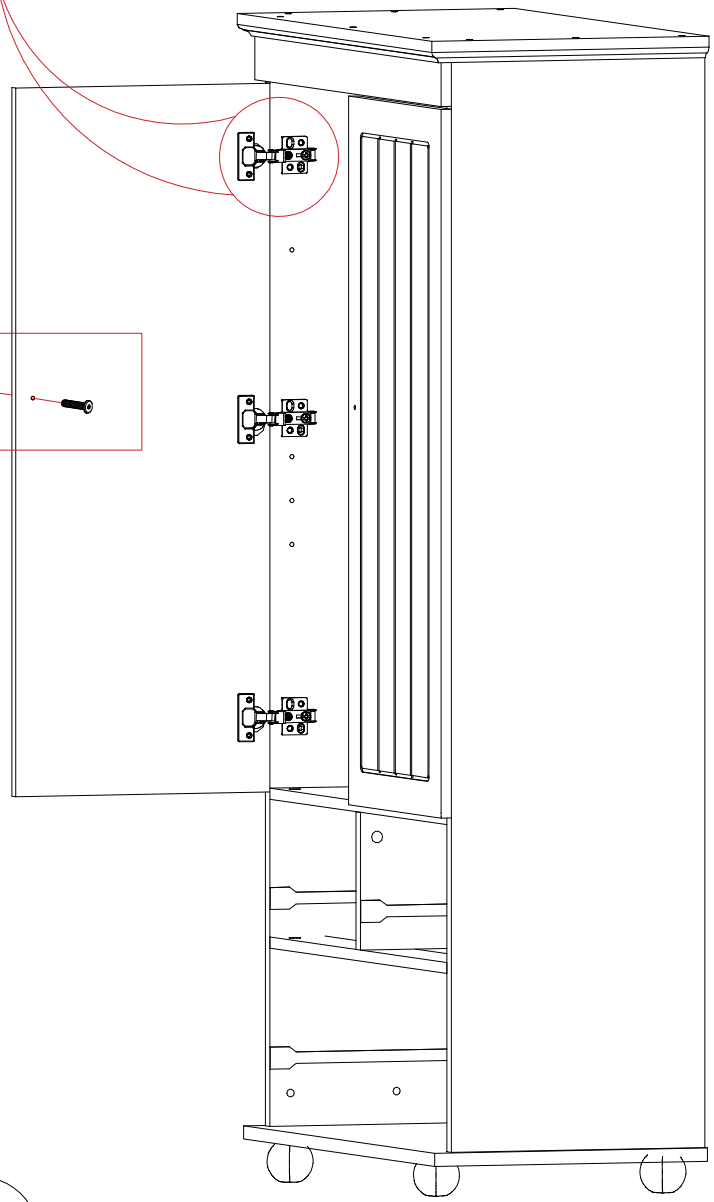
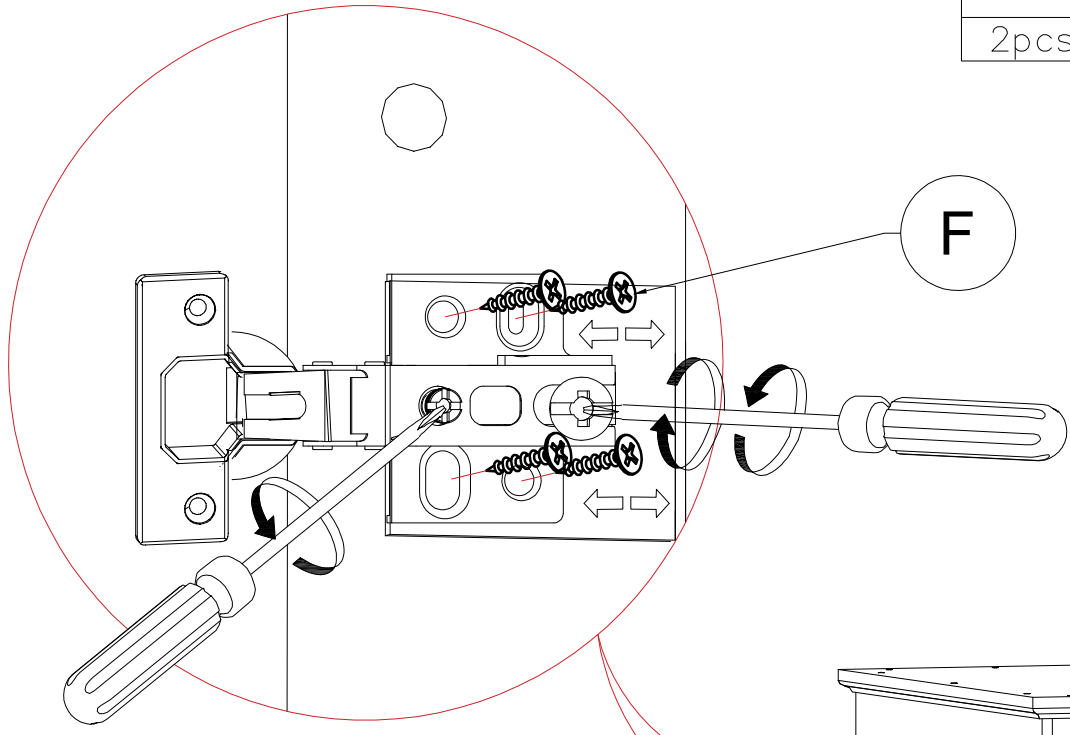

STEP 10.1: Following below illustration:

A	N
8pcs	8pcs

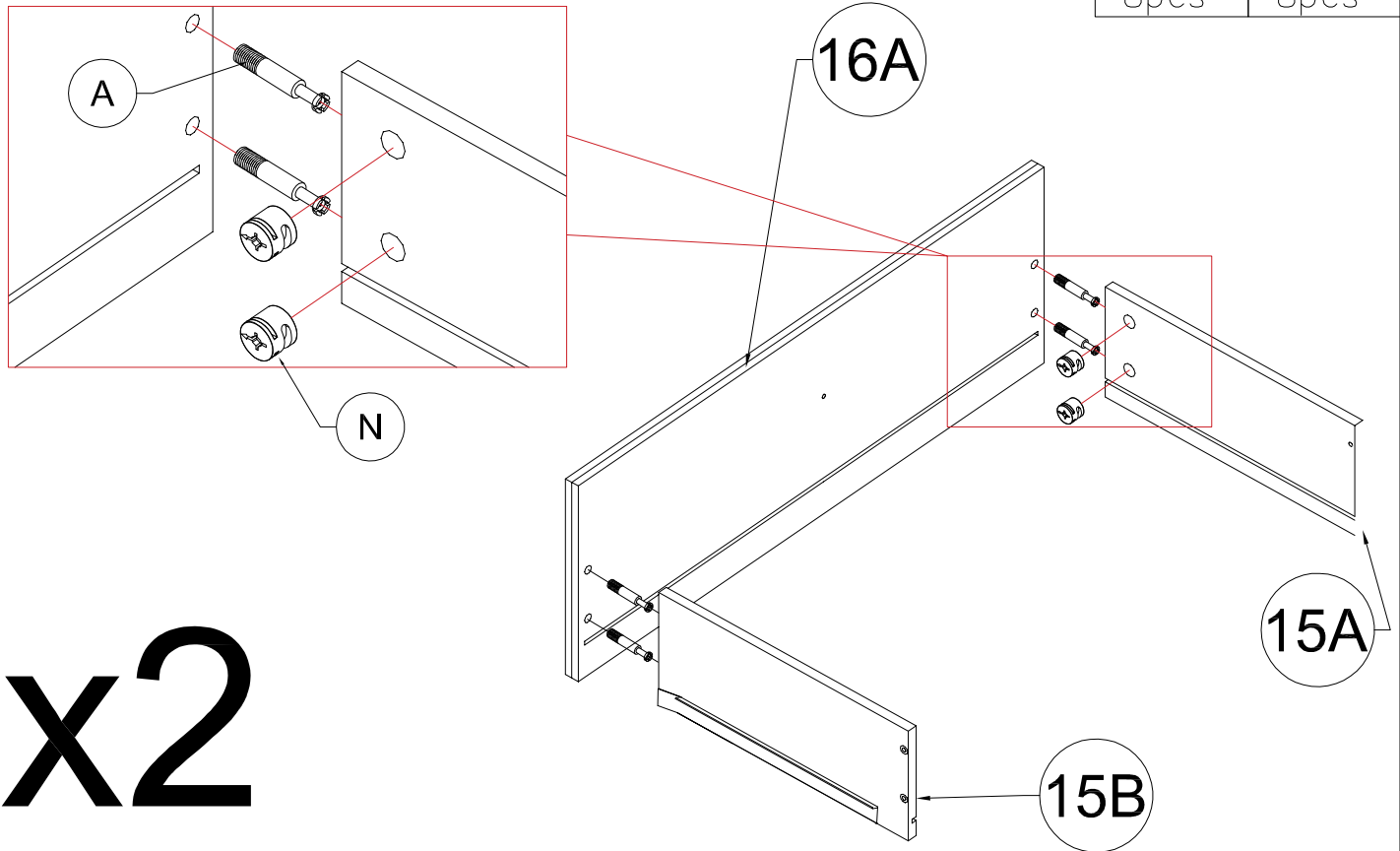

STEP 10.2: Following below illustration:

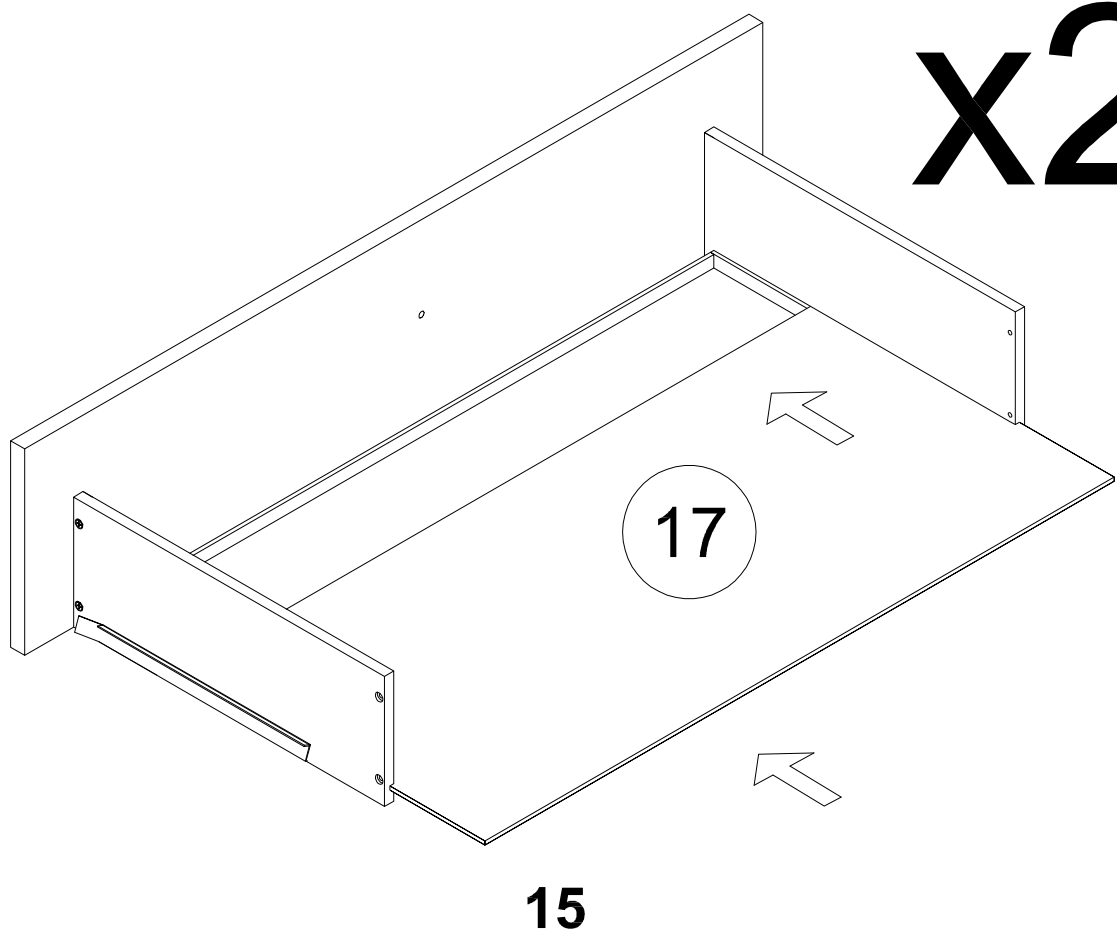

STEP 11.1: Following below illustration:

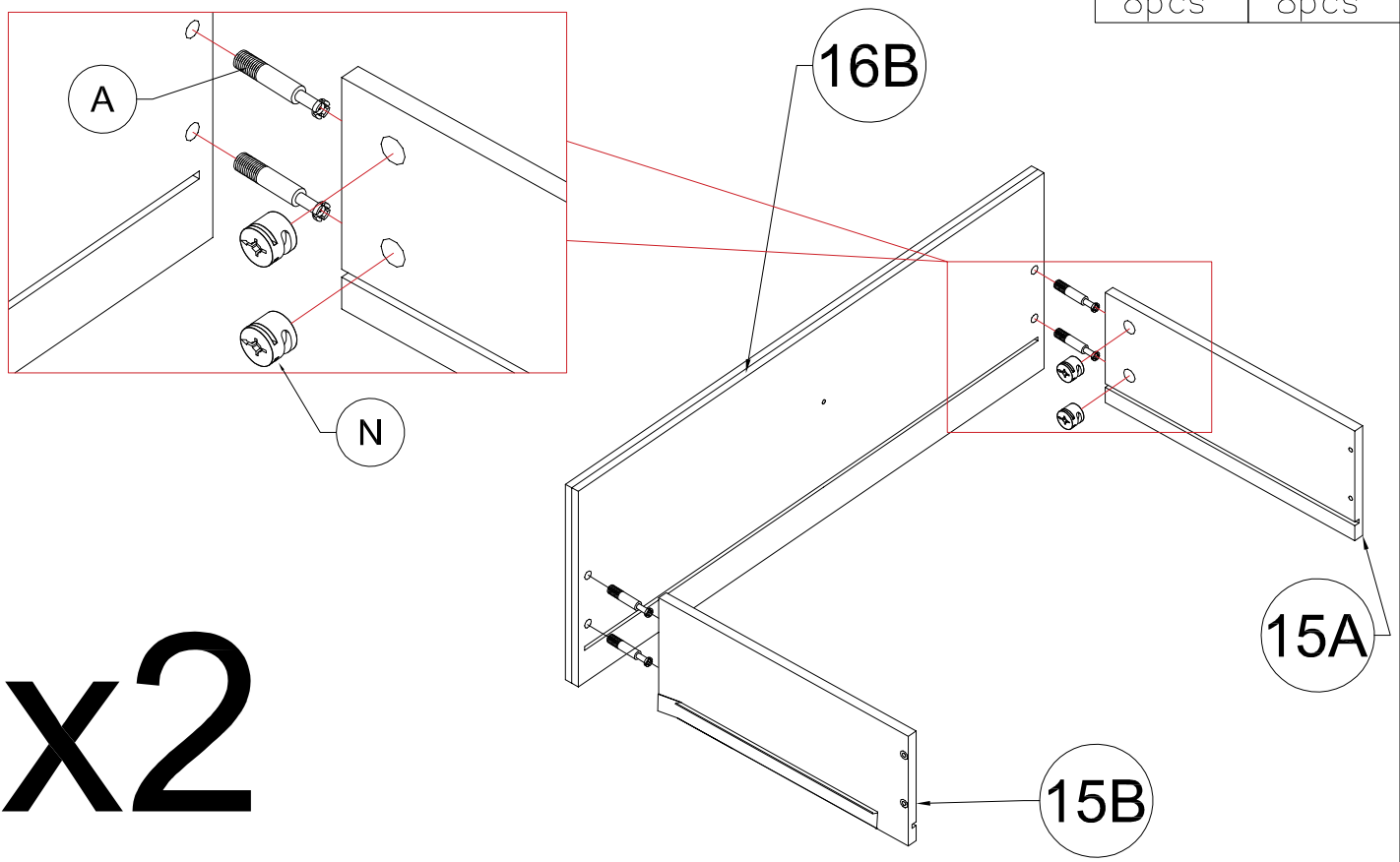

A	N
8pcs	8pcs

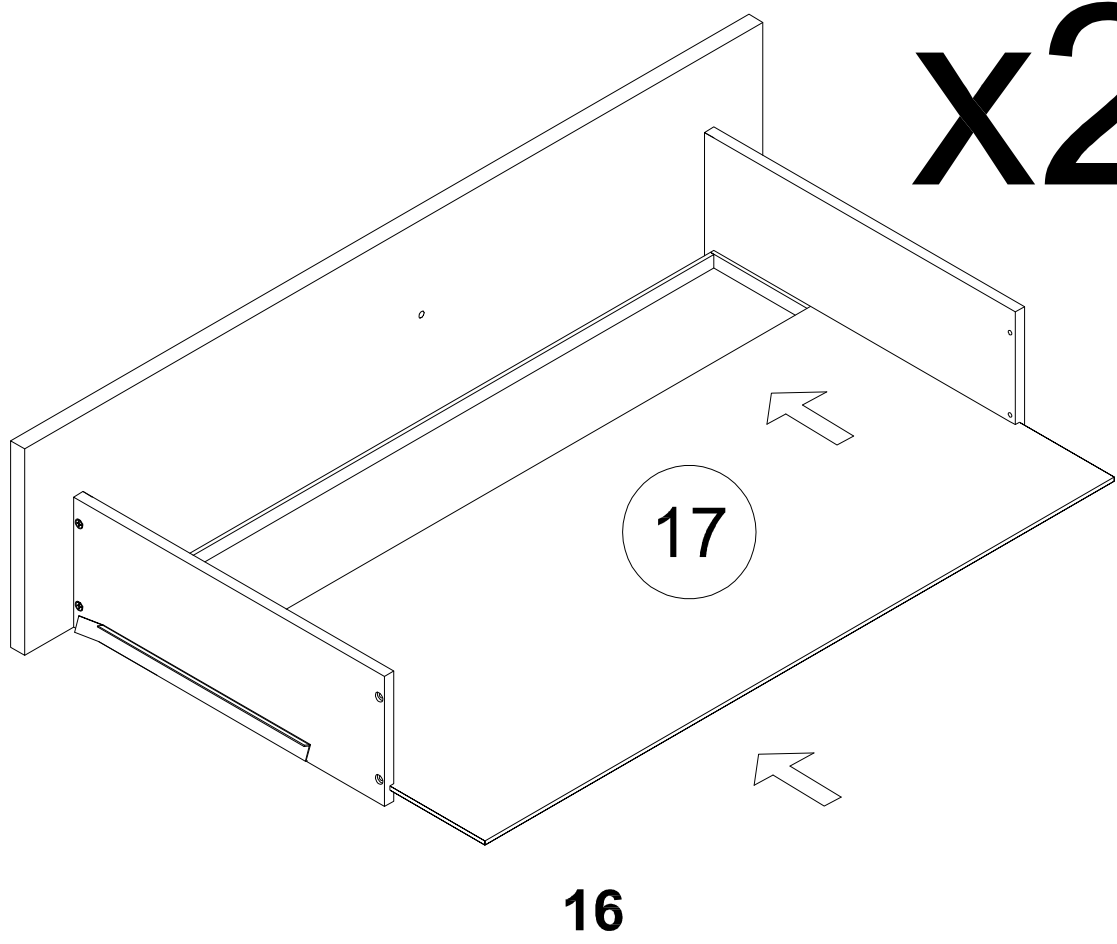

STEP 11.2: Following below illustration:

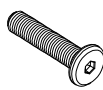

STEP 12: Following below illustration:

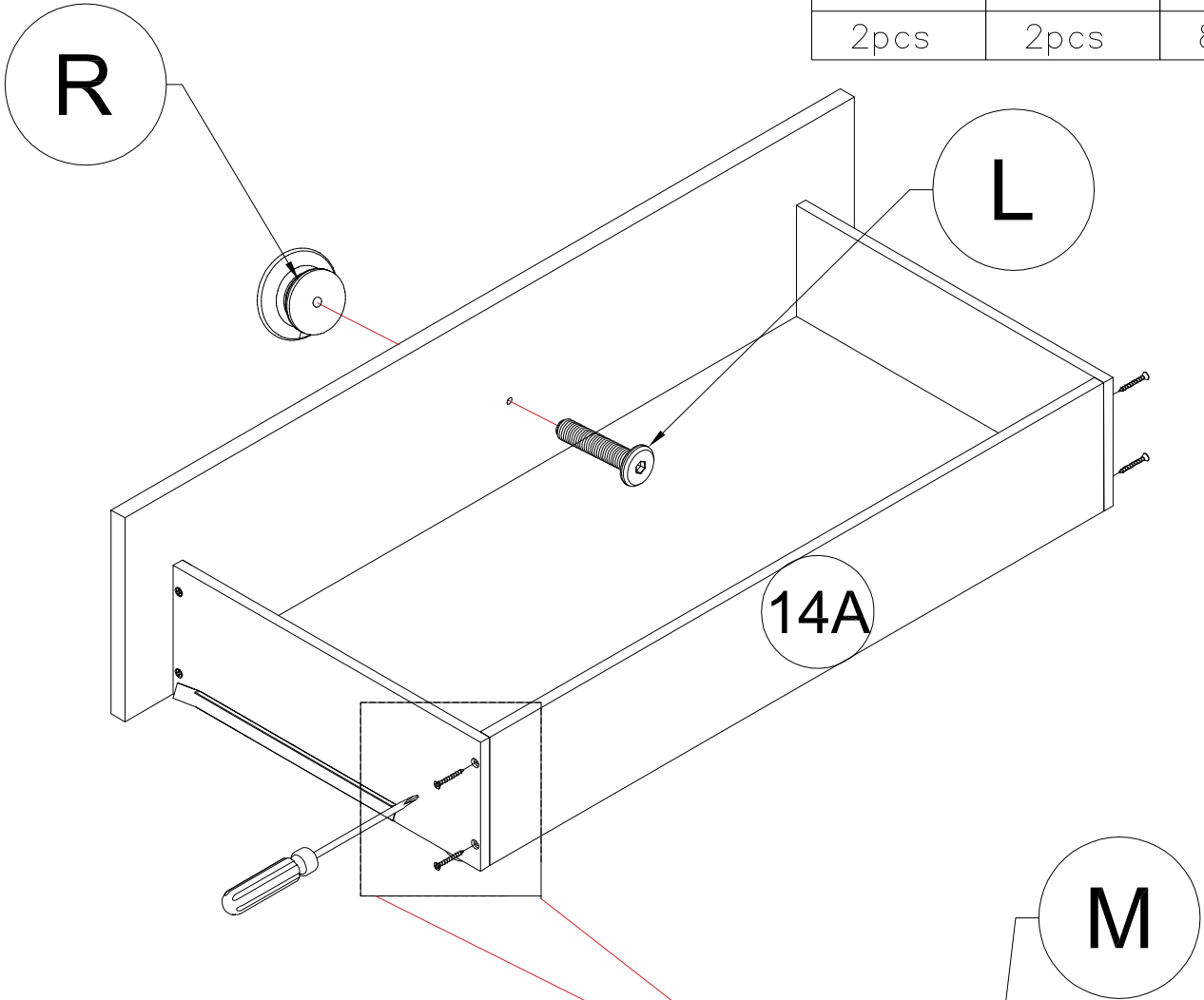

R	L	M
		
2pcs	2pcs	8pcs

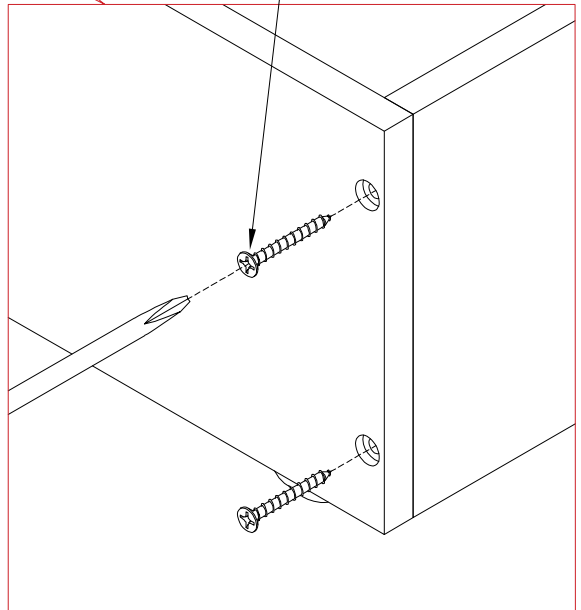

x2

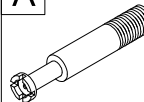

STEP 13.1: Following below illustration:

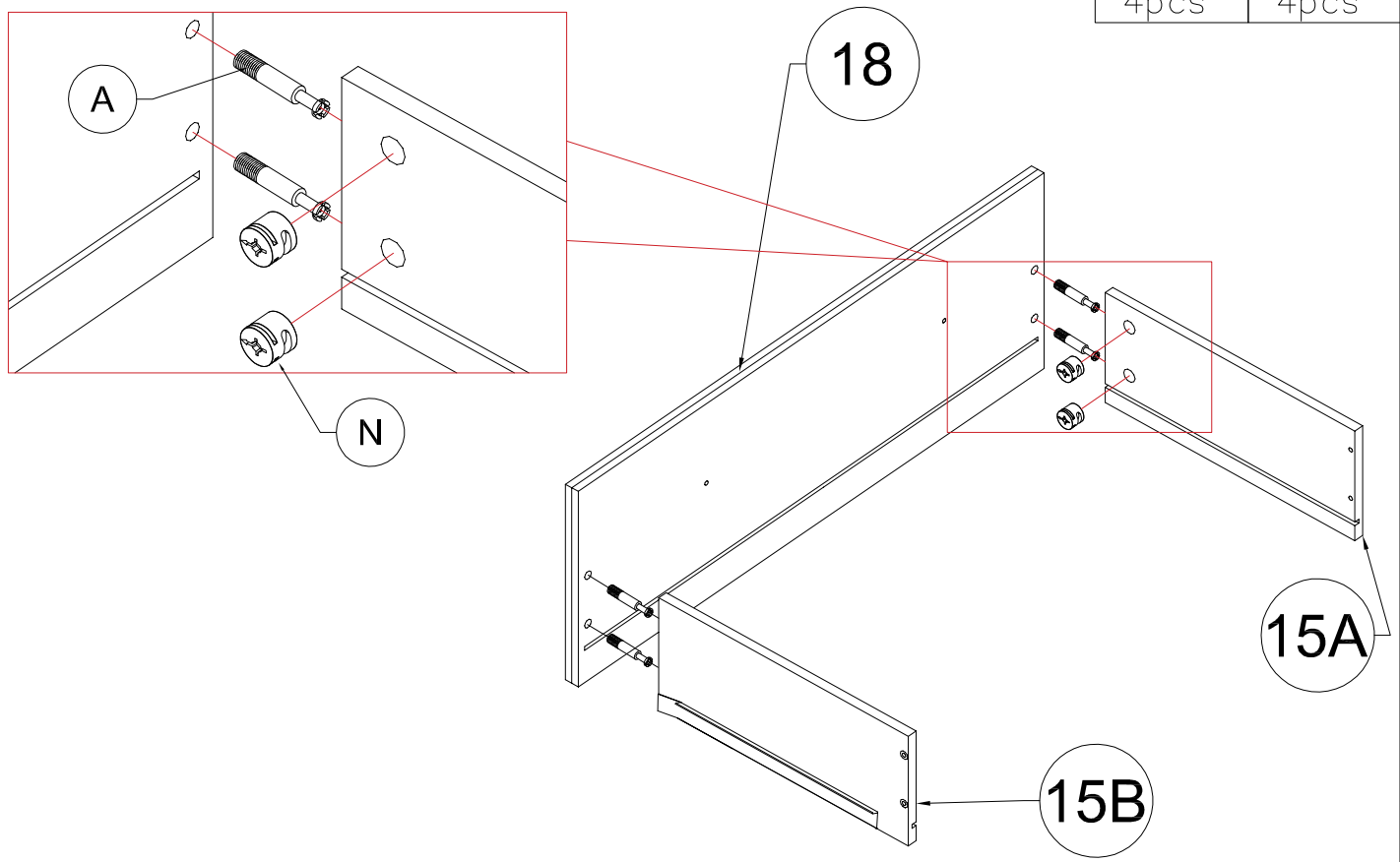

A 	N 
4pcs	4pcs

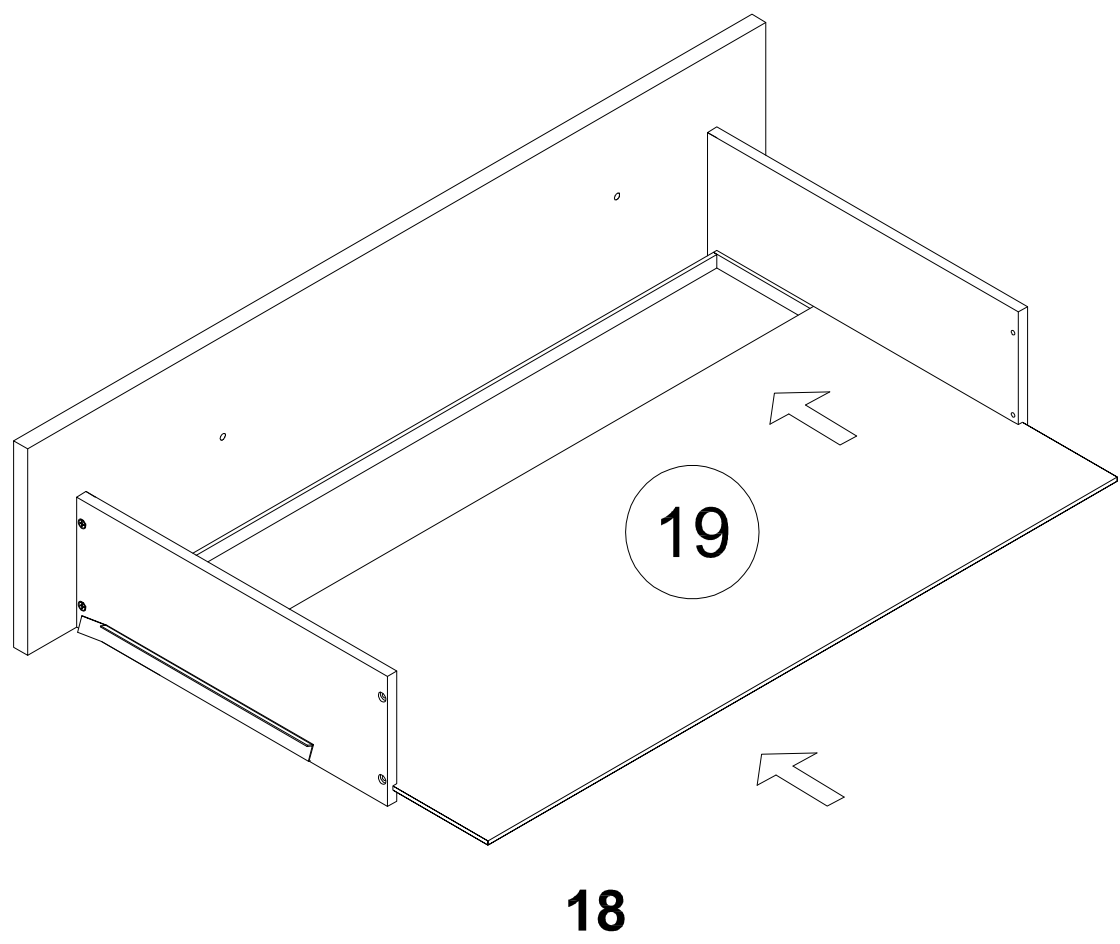

STEP 13.2: Following below illustration:

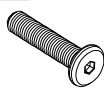

STEP 14: Following below illustration:

R	L	M
		
2pcs	2pcs	4pcs

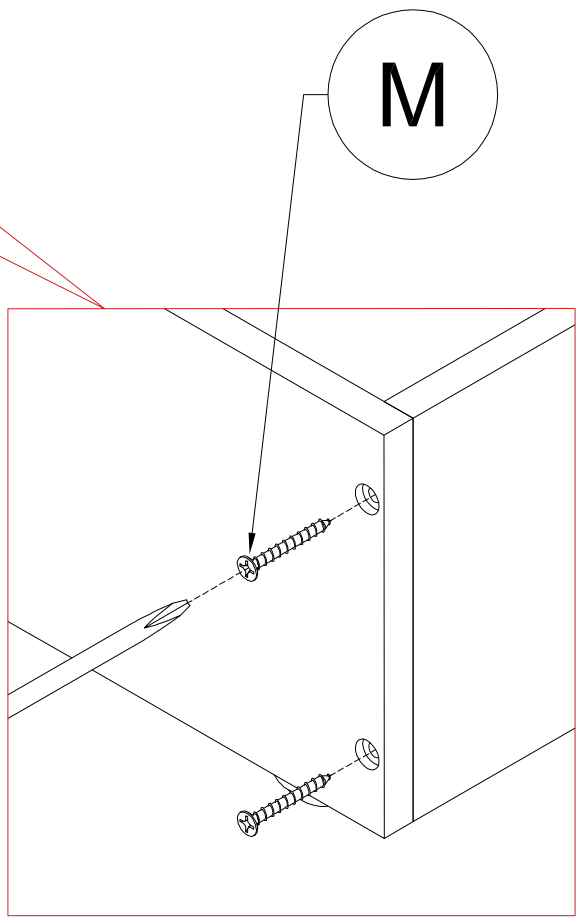
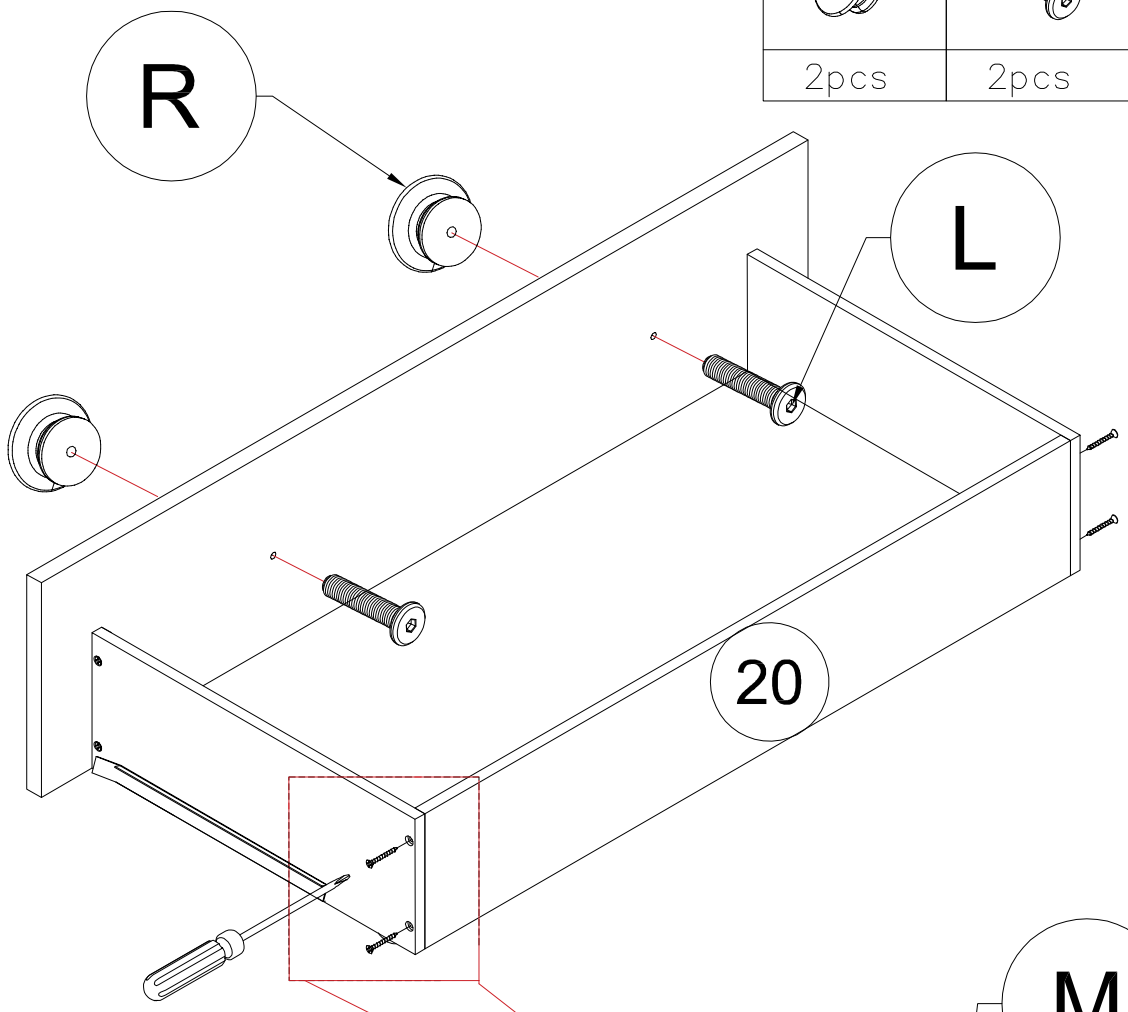

STEP 15: Following below illustration:

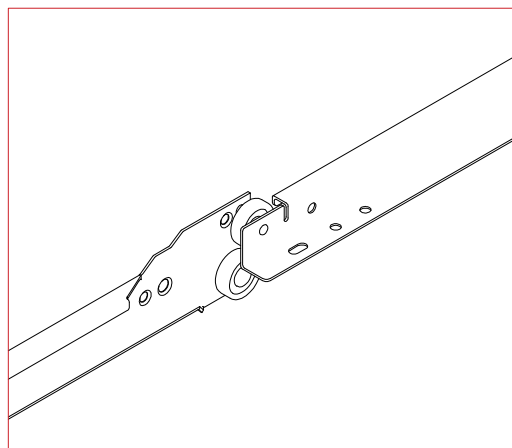
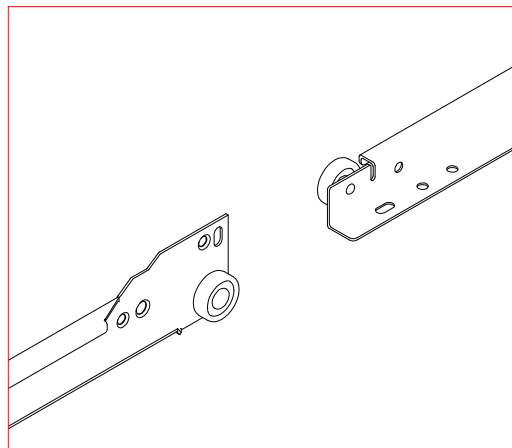
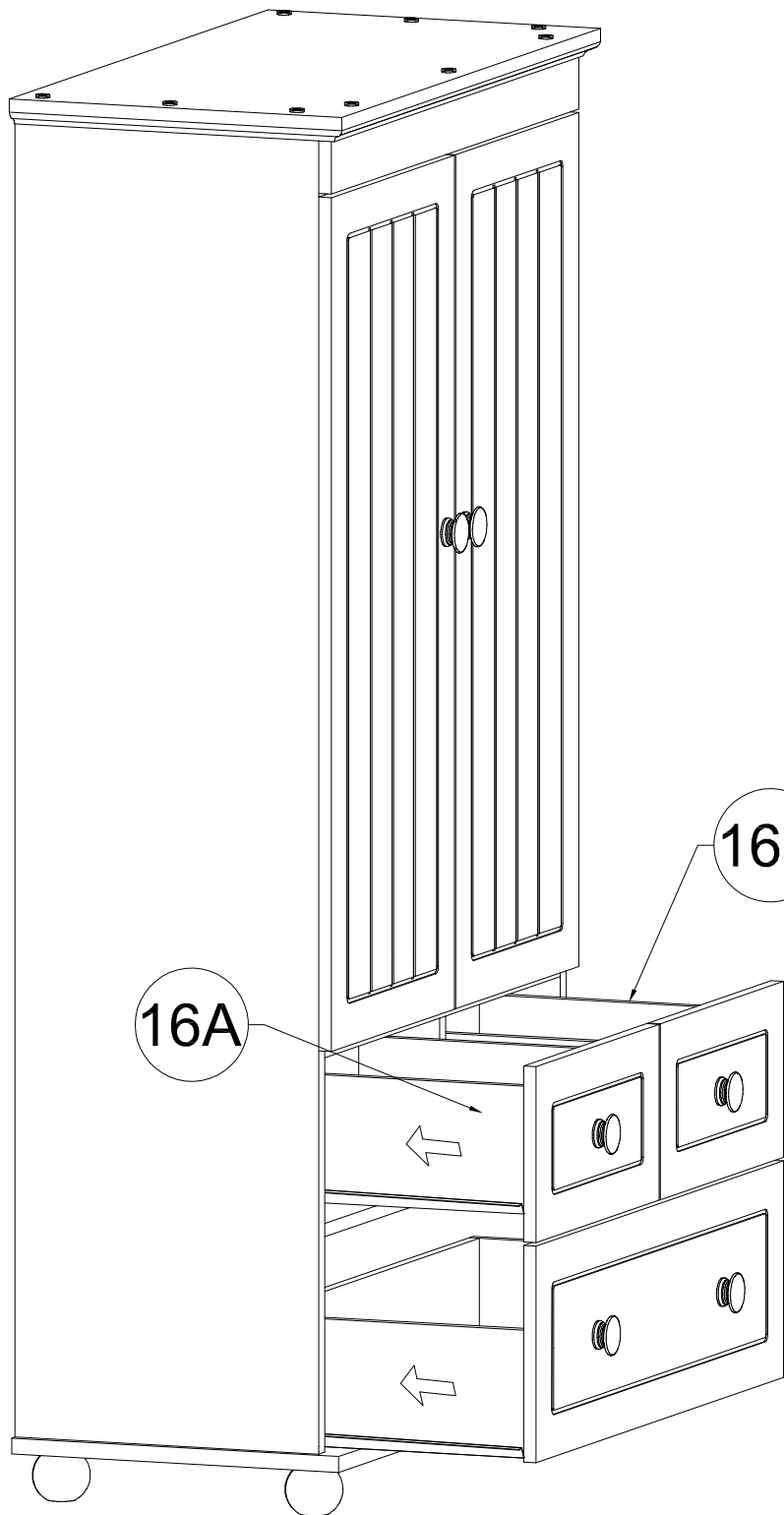

STEP 16: Following below illustration:



J

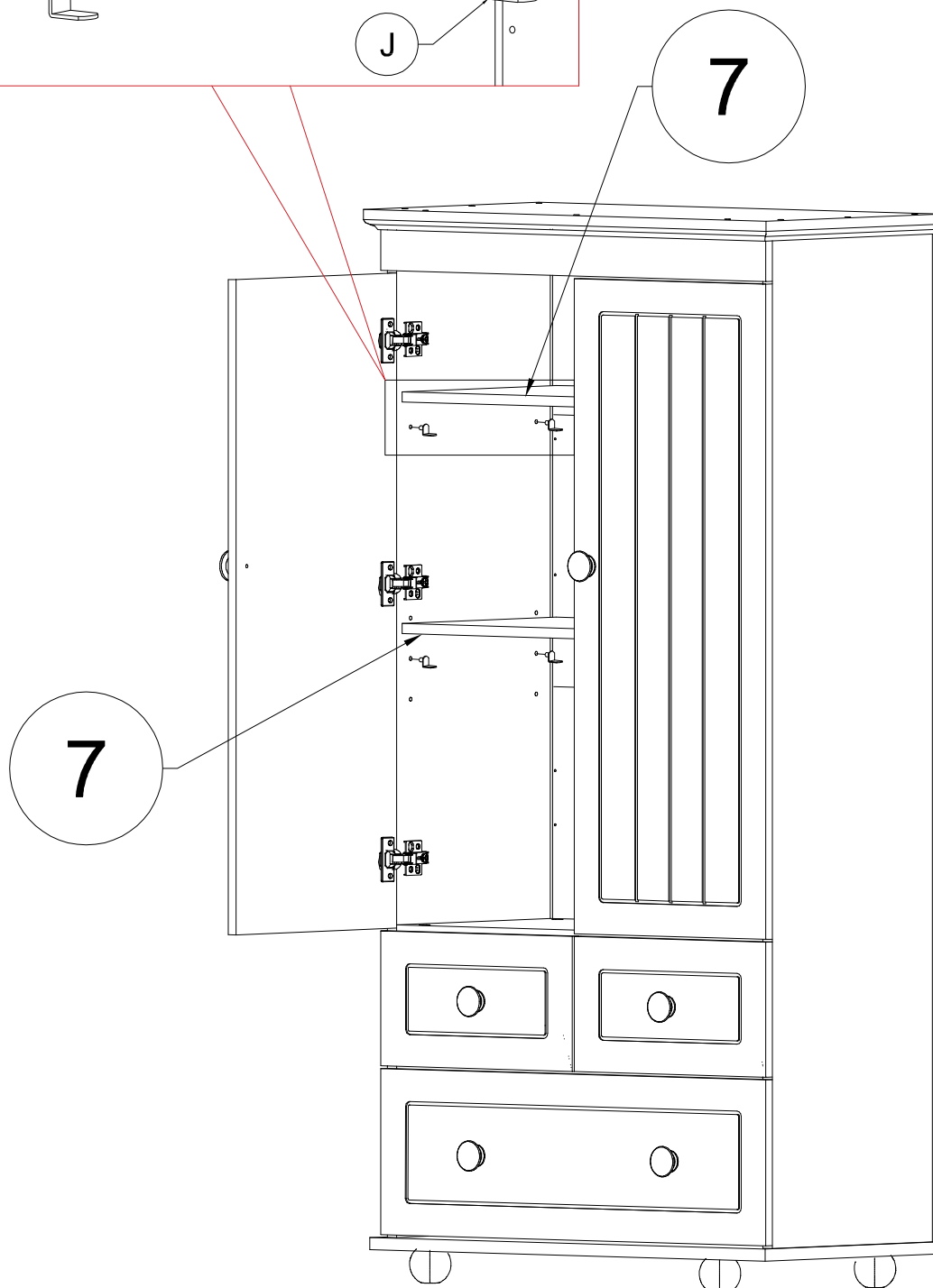
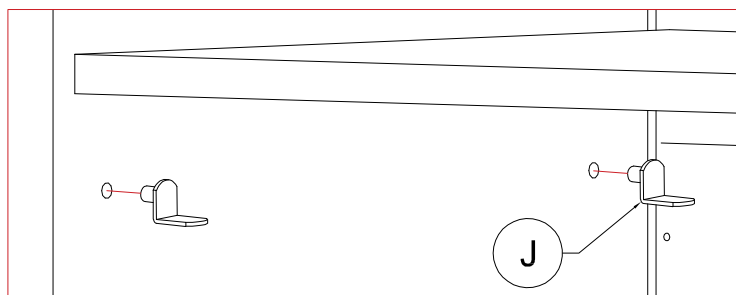

8pcs

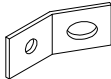

STEP 17: Following below illustration:

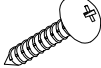

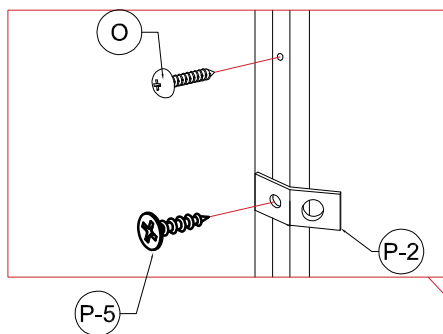
P-2	P-5	O
		
2pcs	2pcs	27pcs

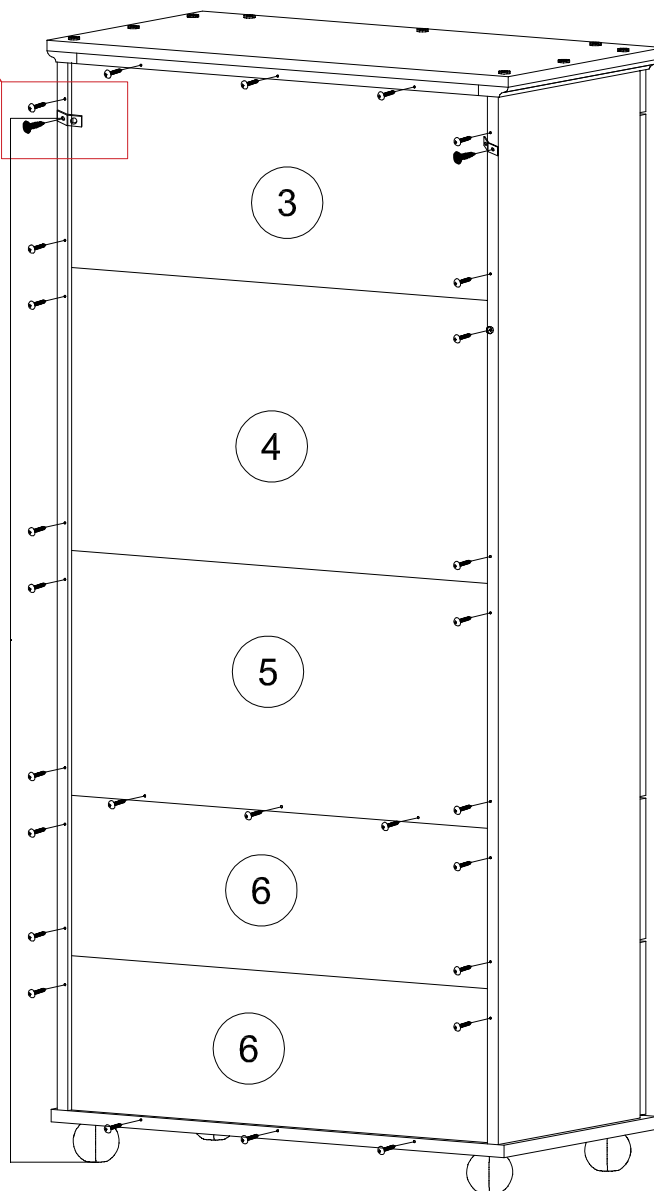

1450MM

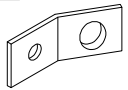

STEP 18: Following below illustration:

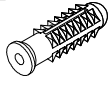
P-2	P-4	P-3
		
2pcs	2pcs	2pcs

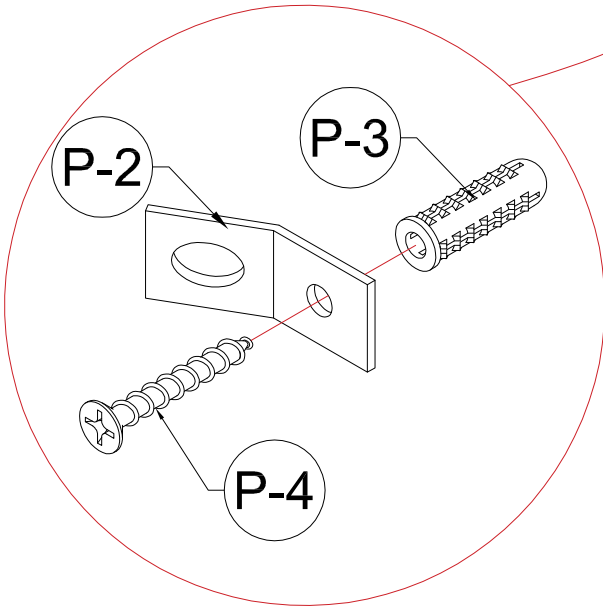
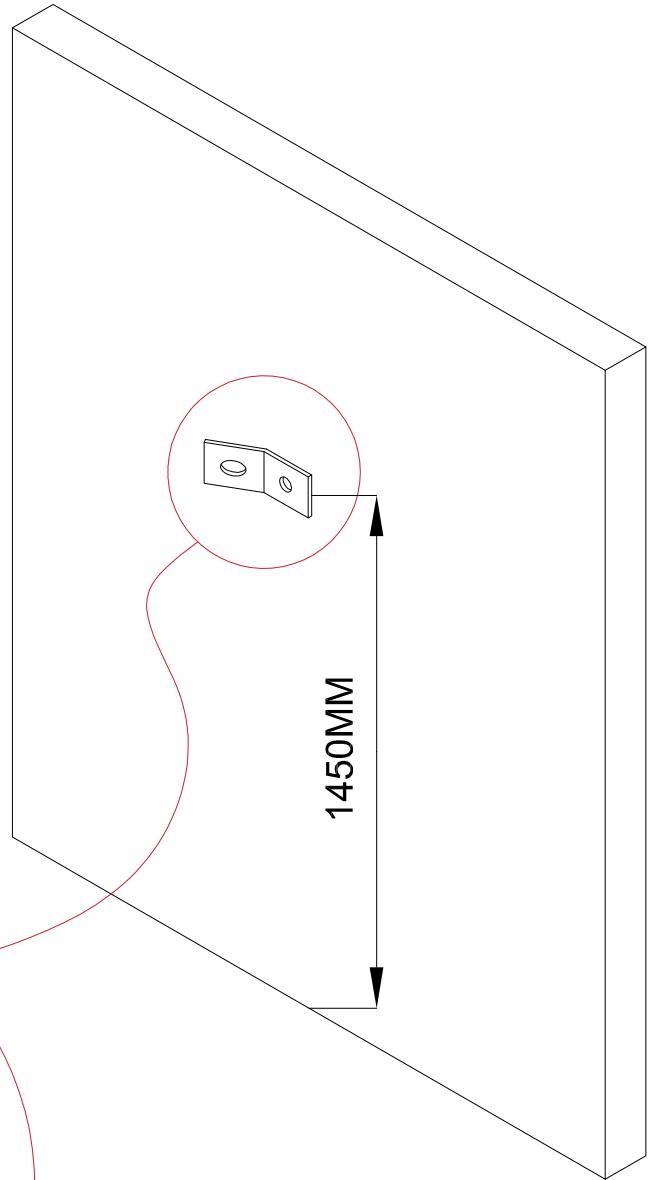

STEP 19: Following below illustration:

P-1



2pcs

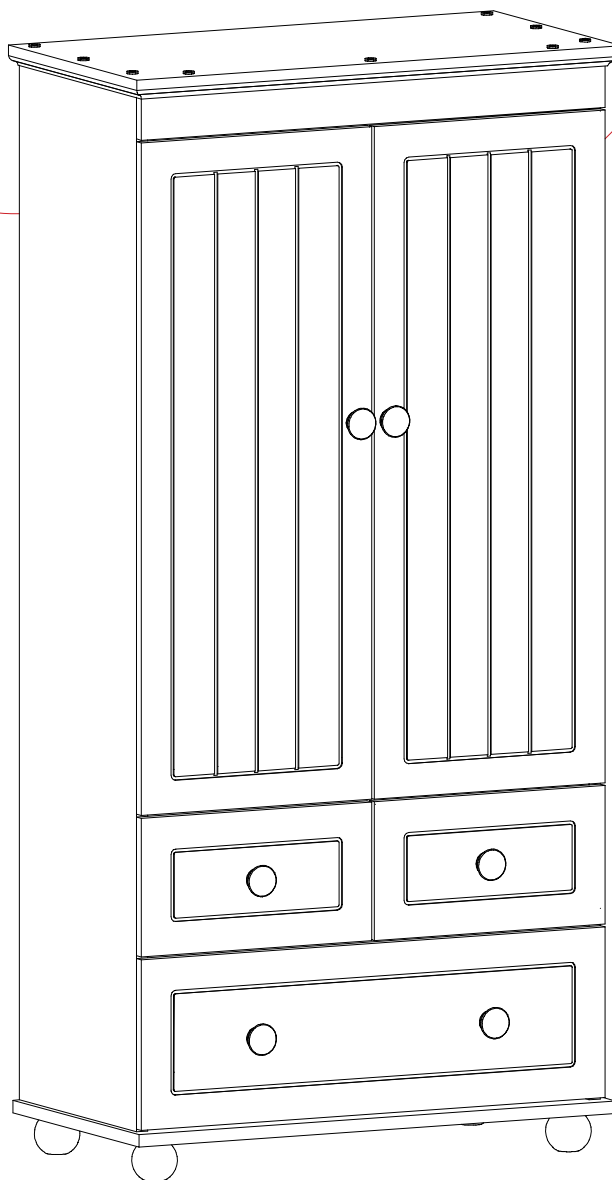
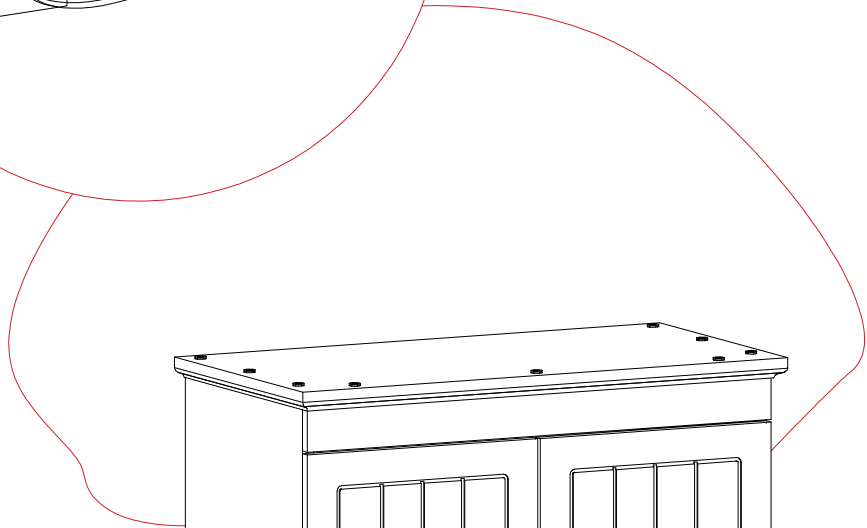
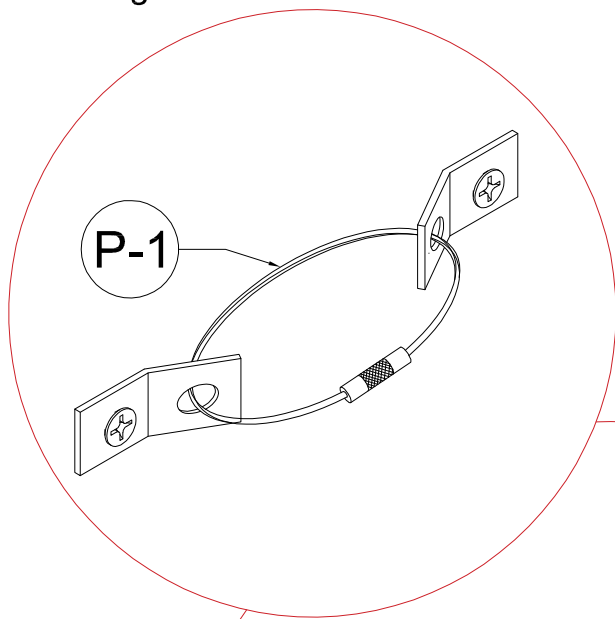

FINISH

