

Assembly Instructions

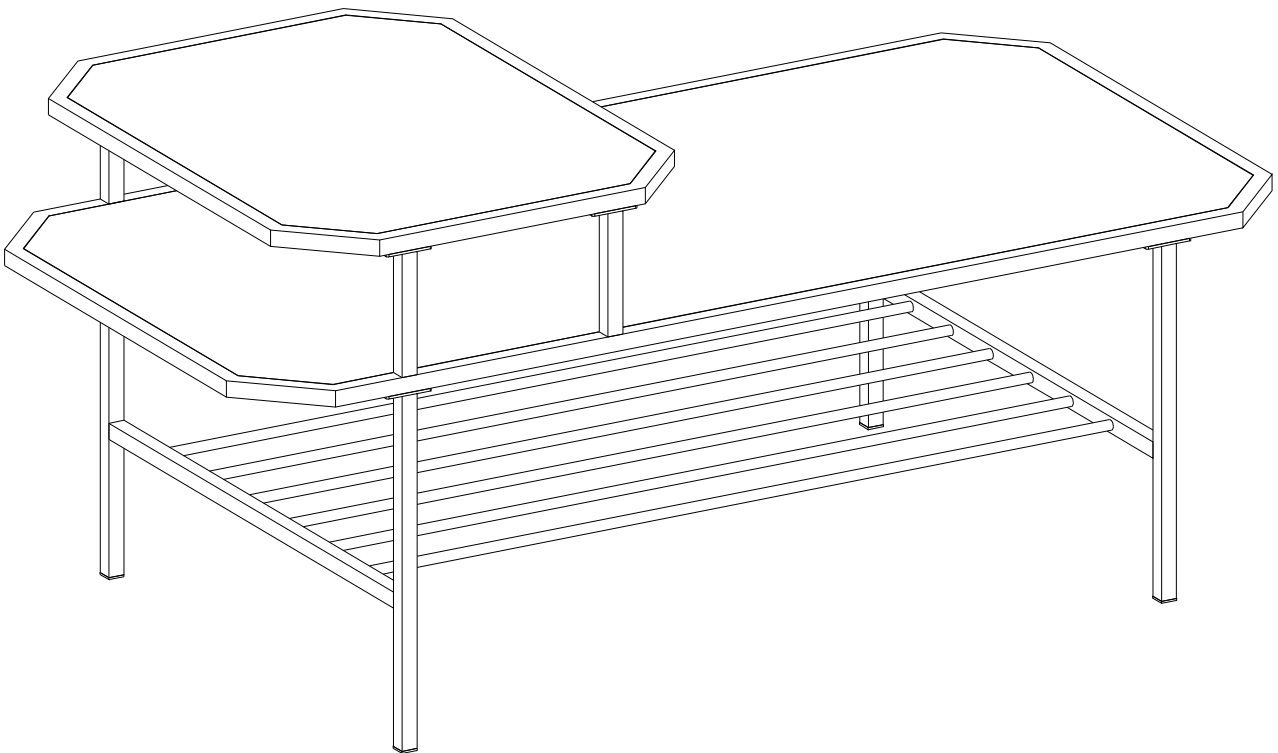

General Assembly Guidelines

- I. Ensure that all parts and hardware are available before beginning assembly.
- II. Follow each step carefully to ensure the proper assembly of this product.
- III. Two people are recommended for ease in the assembly of this product.
- IV. The main type of hardware used to assemble this product are: bolts and screws.
- V. Power tools should not be used to assemble this product.

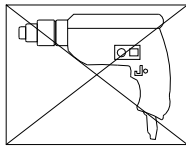

- VI. Drill may be needed for securing product to wall.

Parts List

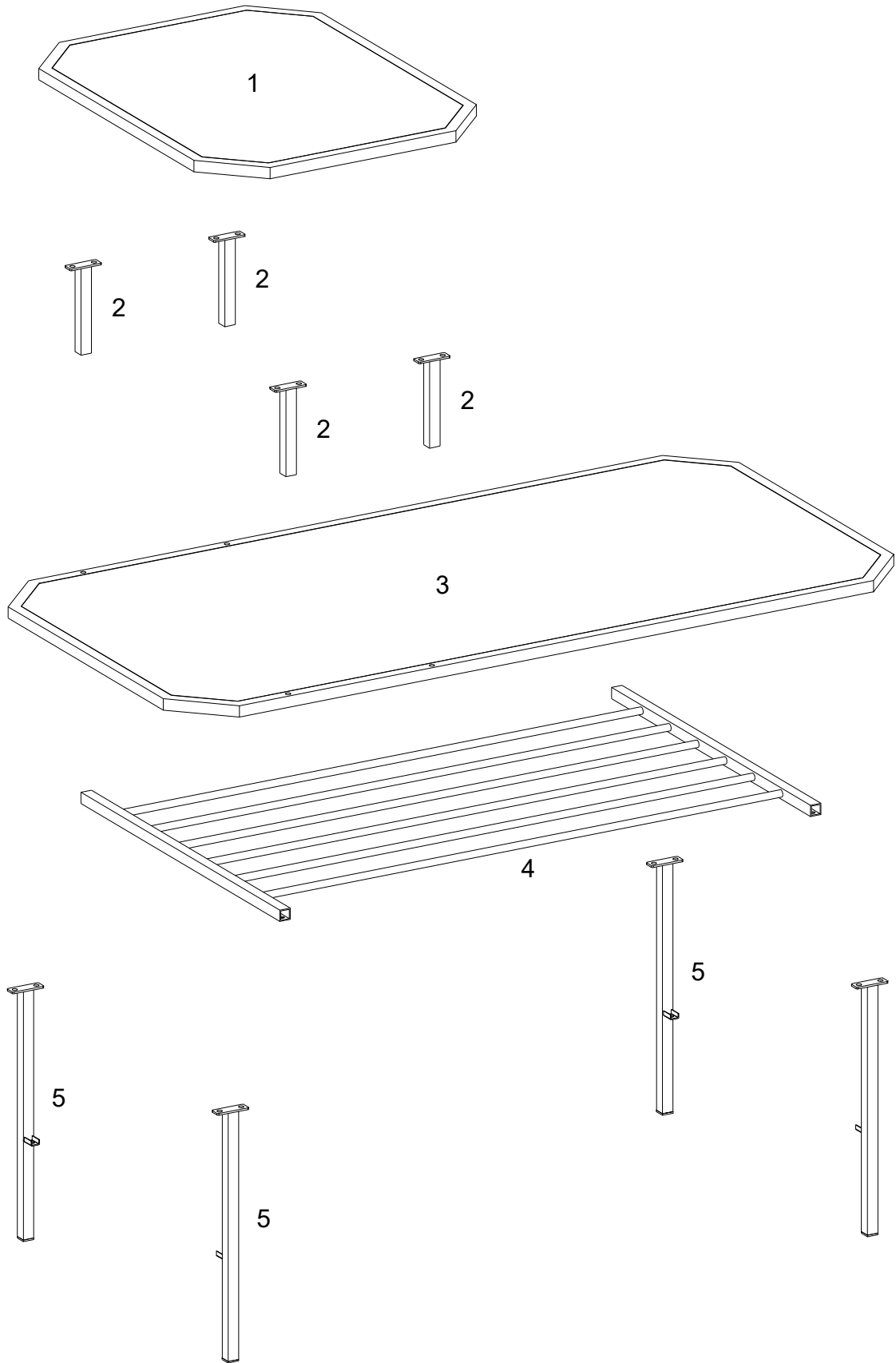

Hardware List

A		M6x12mm	Bolt	20 pcs
B		M6x25mm	Bolt	4 pcs
C		M4	Hex Key	1 pc

*The hardware quantities listed above are required for proper assembly.
Some extra hardware may also have been included.*

Step 1

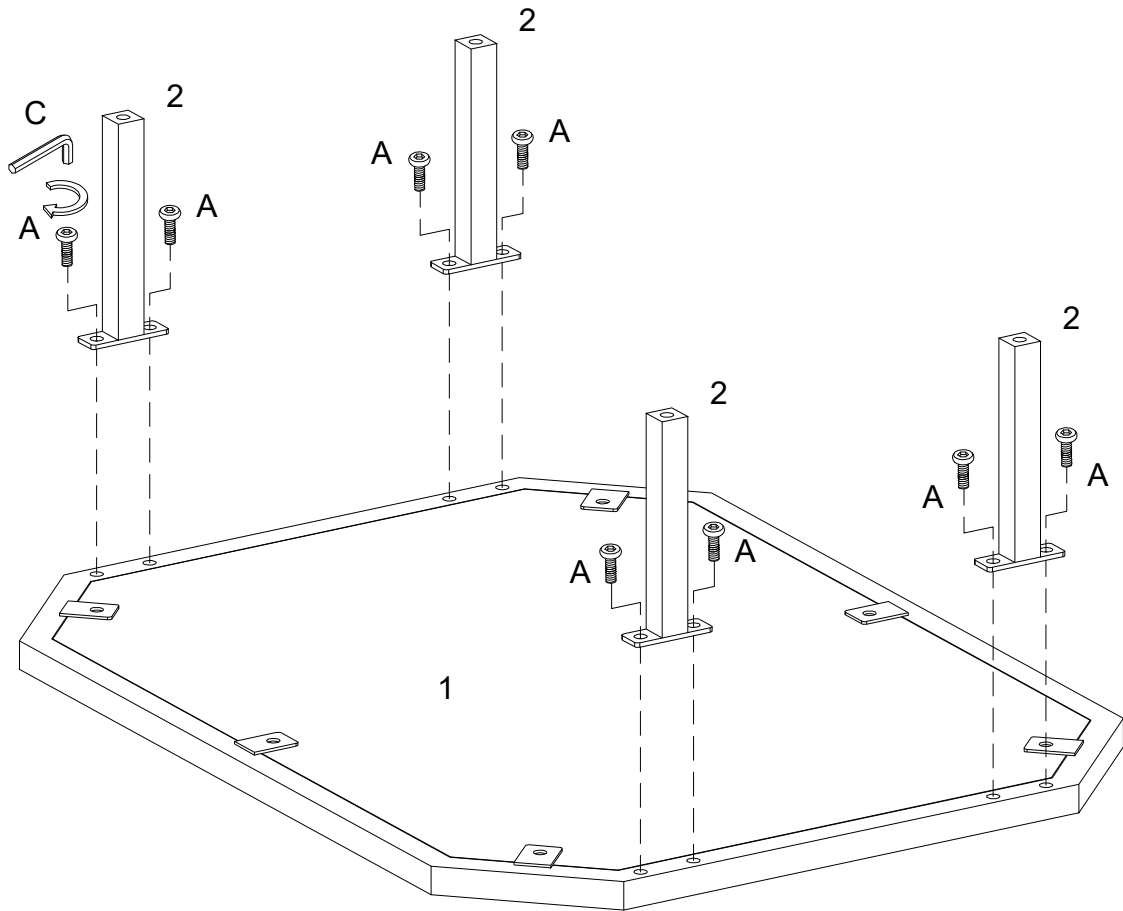

Using bolt (A) attach parts (2) to part (1) with Hex key (C) as per diagram.

Note: Please do not fully tighten all bolts.

Step 2

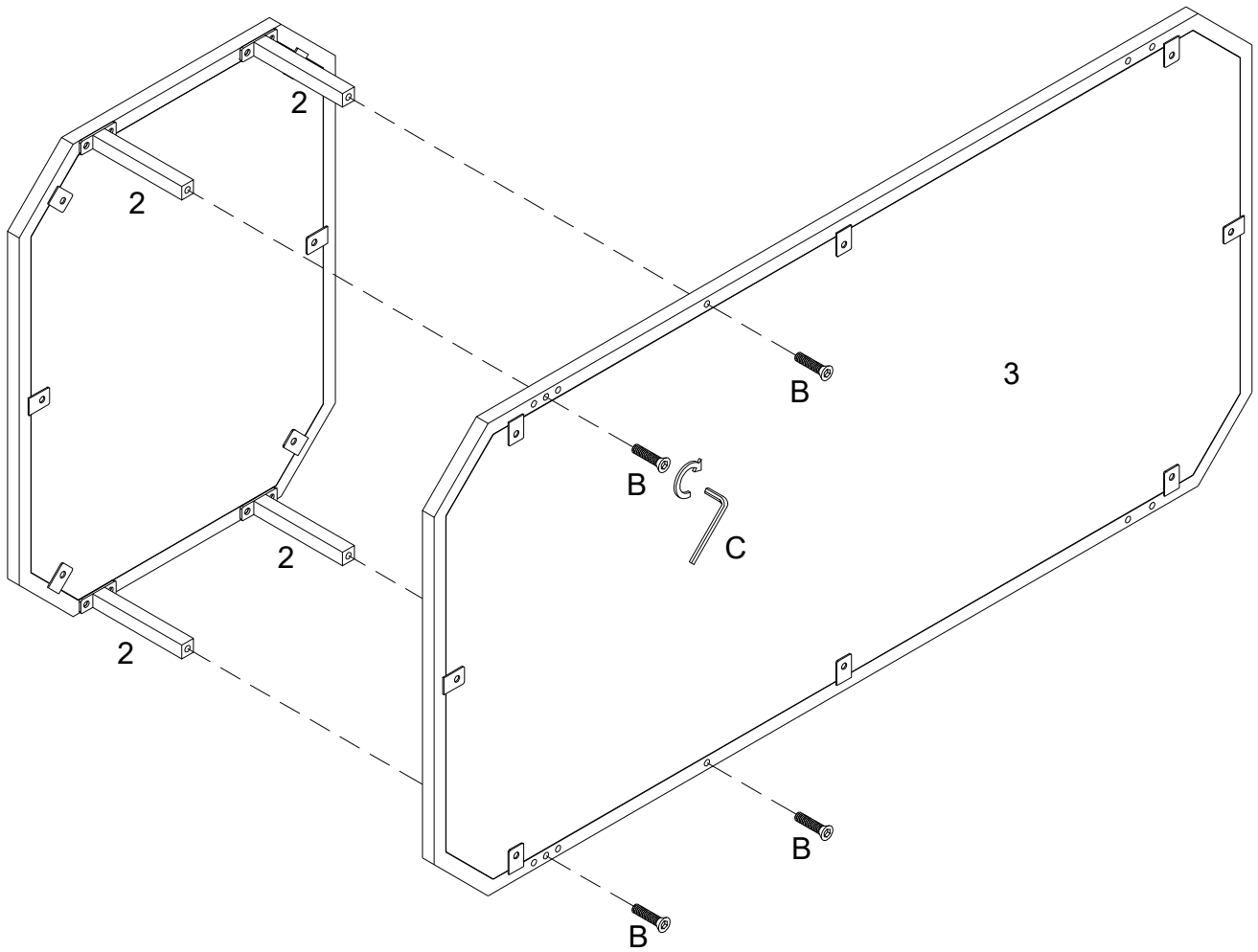

Using bolt (B) attach part (3) to part (2) with Hex key (C) as per diagram.
Note: please fully tighten all bolts at this step .

Step 3

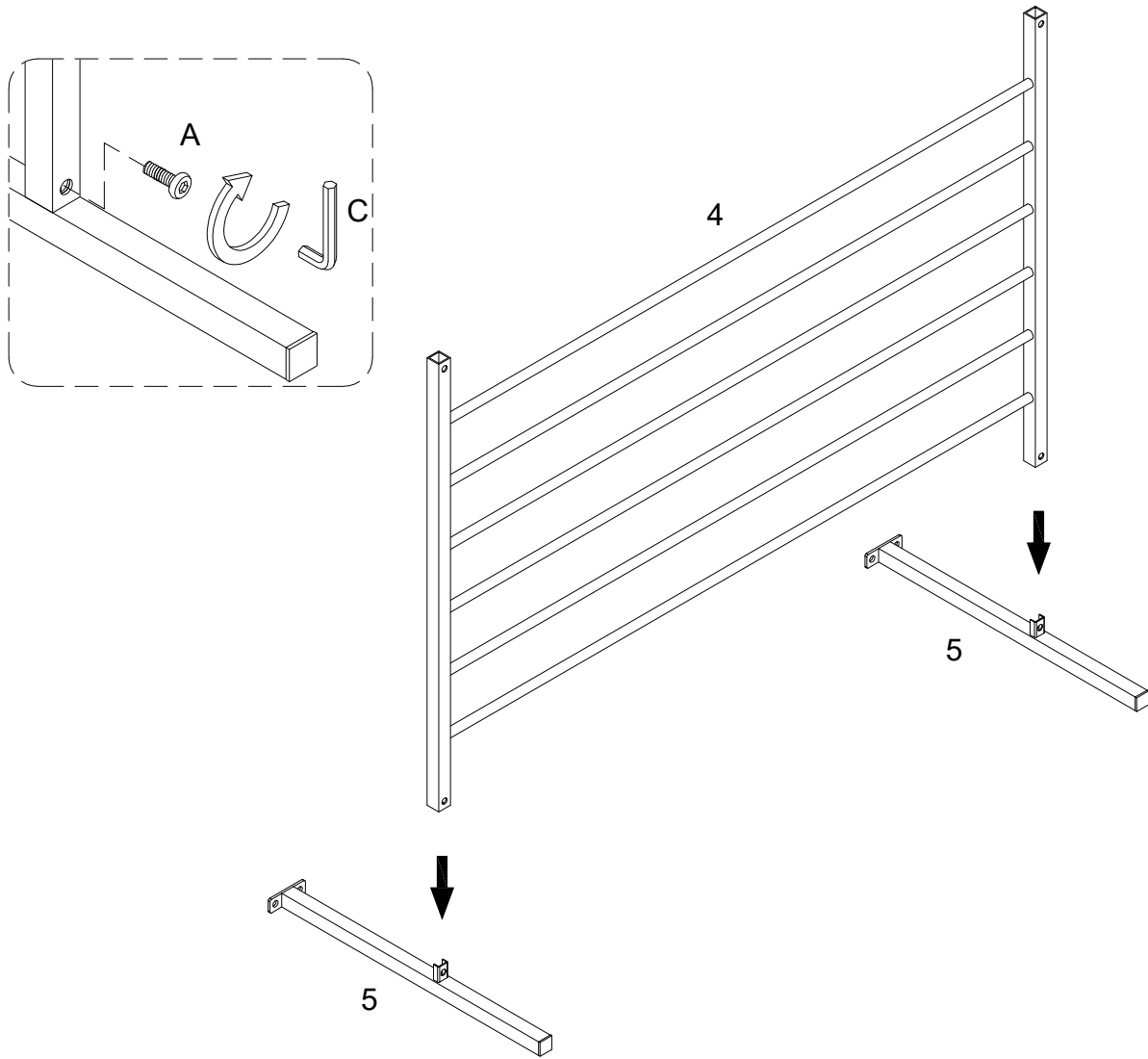

Attach part (4) to part (5) ,then using bolt (A) secure part (4) to part (5) with Hex key (C) as per diagram.

Note: Please do not fully tighten all bolts at this step .

Step 4

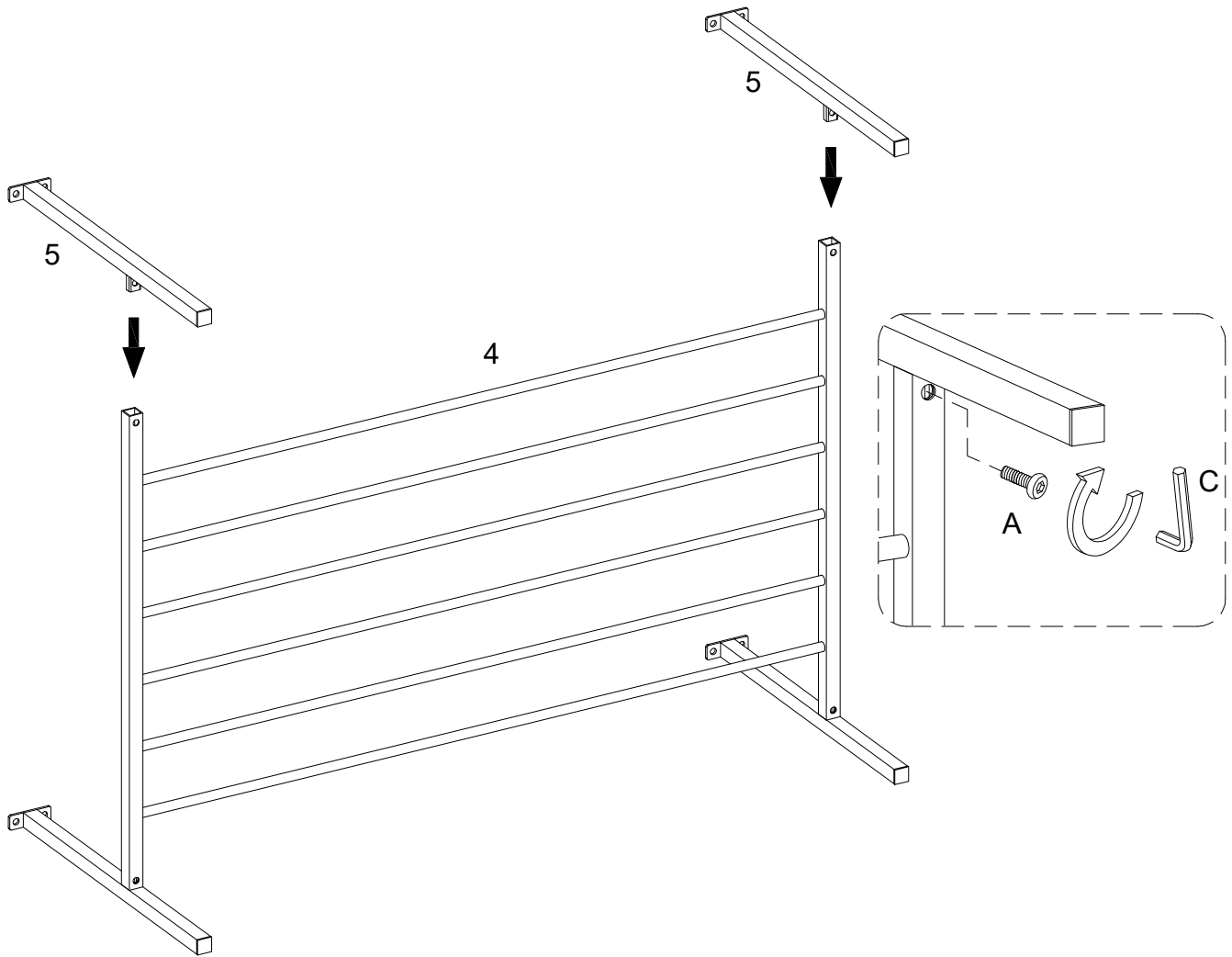

Attach part (5) to part (4) ,then using bolt (A) secure part (4) to part (5) with Hex key (C) as per diagram.

Step 5

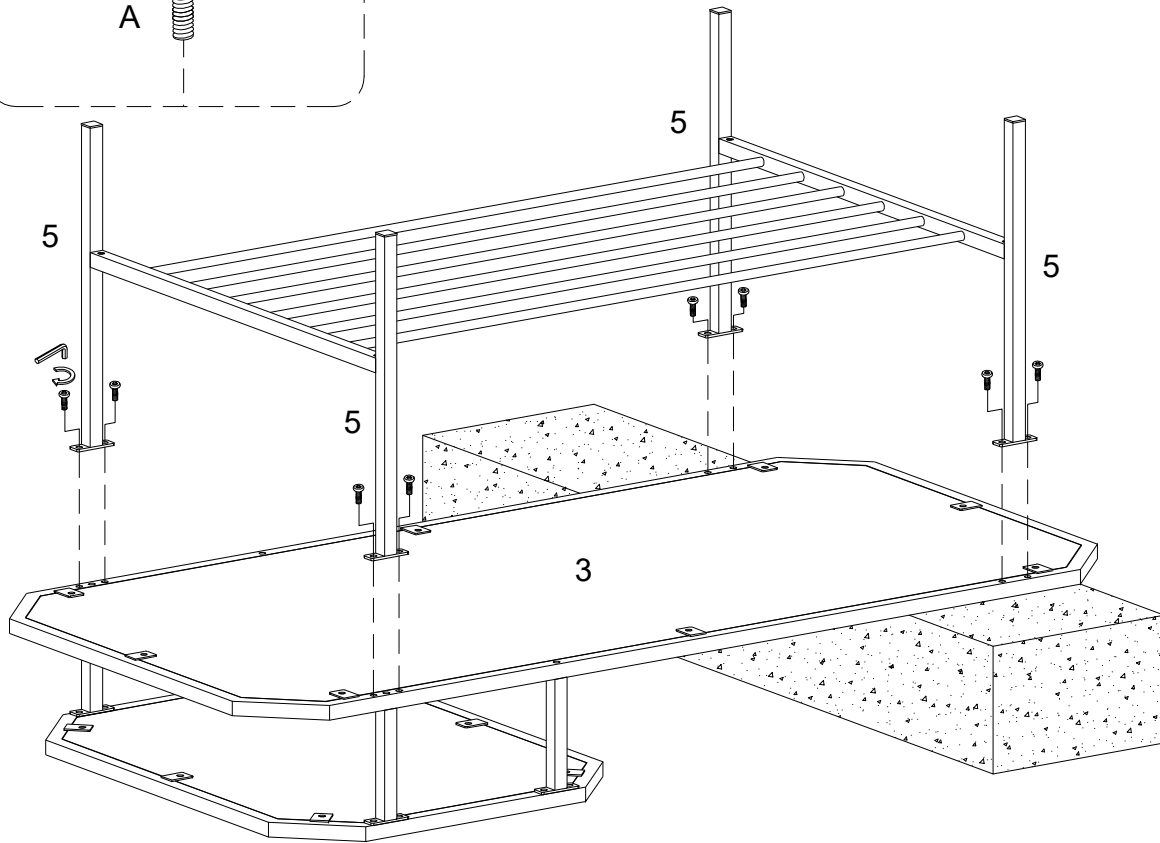
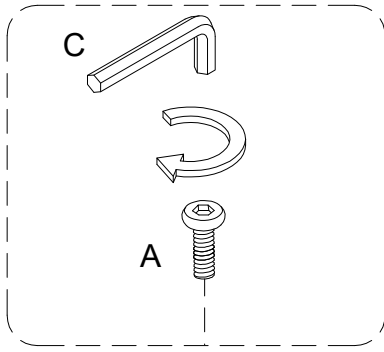

Using bolt (A) attach parts (5) to part (3) with Hex key (C) as per diagram.
Note: please fully tighten all bolts .

Step 6

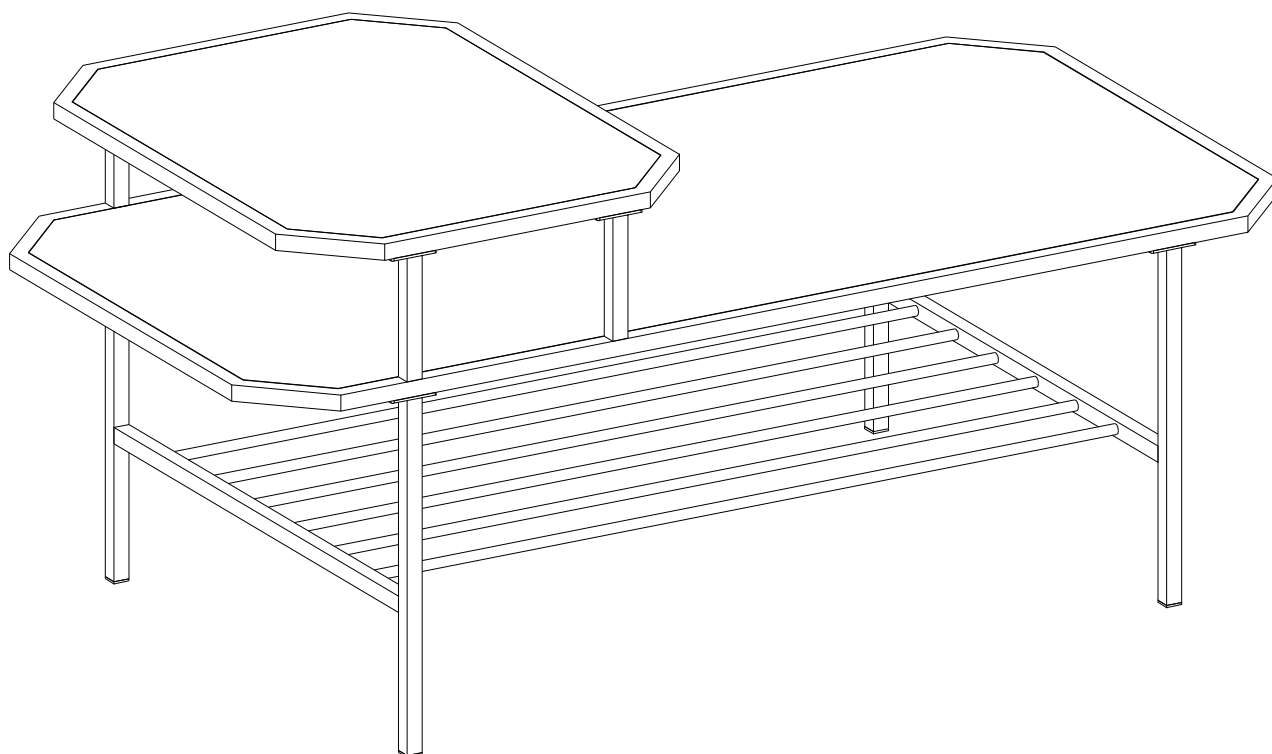

Final Assembly