

# ASSEMBLY INSTRUCTIONS

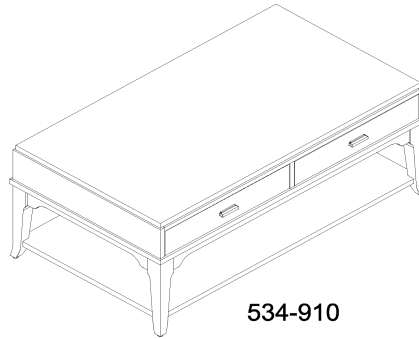

## TOOLS REQUIRED:

- Allen Wrench (Provided, Part G)
- Allen Key (Provided, Part H)
- Phillips Screw Driver (Not Provided)

## BEFORE YOU START:

1. Check the hardware against the hardware list to make sure all items are present.
2. Assemble your furniture on a soft, flat surface to avoid scratching the finish.
3. CAUTION: Do not over tighten screws, nuts or bolts during assembly.
4. Your furniture may require occasional tightening.

## INSTRUCTIONS:

1. Turn the table on to a clean soft surface .
2. Attach the legs to the Table Top using Hex nuts (B), Lock Washer(E), Flat washer (F) and using Wrench(G) (Do not tighten completely yet). As shown in Figure 1 .
3. Attach bottom shelf to the legs using Bolt (A), Lock Washer(C), Flat Washer (D) and using Allen Key(H) (Do not tighten completely yet). As shown in Figure 2 .
4. Tighten all bolts using Wrench(G) and Allen Key(H) After completing step 3.
5. Attach the Casters (J) to the bottom shelf using Screw (I) As shown in figure 3
6. Set table back up right and open the Drawer. Take the handle out and reassemble it. As shown in Figure 4 .

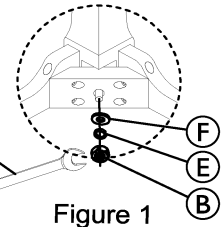

Figure 1

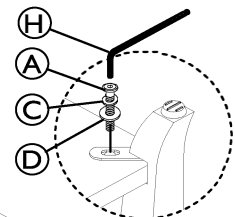
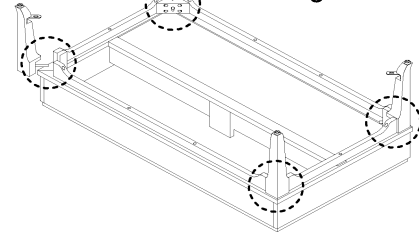

Figure 2

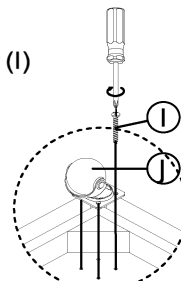

Figure 3

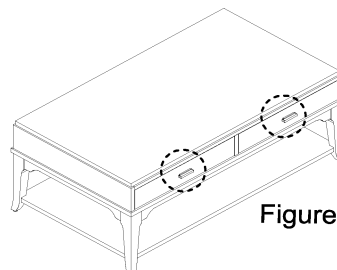
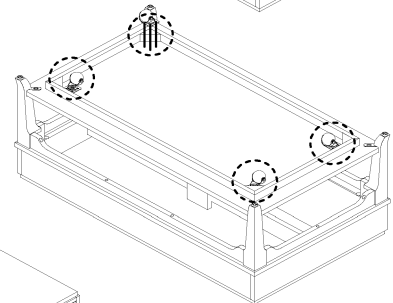
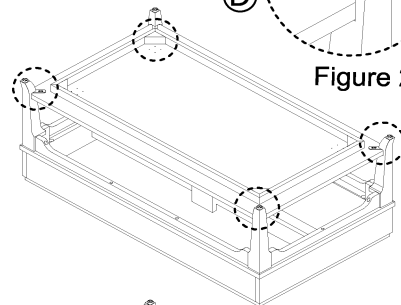

Figure 4

## HARDWARE LIST

A		Ø1/4"x3/4" Bolt	4pcs
B		Ø5/16" Hex Nuts	4pcs
C		Ø1/4"x10mm Lock Washer	4pcs
D		Ø1/4" x16mm Flat Washer	4pcs
E		Ø5/16"x13mm Lock Washer	4pcs
F		Ø5/16" x19mm Flat Washer	4pcs
G		13mm Wrench	1pc
H		1/4"x100mm Allen Key	1pc
I		Ø5/32"x18mm Screw	16pcs
J		Castors (55x64x64mm)	4pcs