

ASSEMBLY INSTRUCTIONS



OFFICE CHAIR

ASSEMBLY INSTRUCTIONS

ASSEMBLY TIPS:

1. Remove hardware from box and sort by size.
2. Please check to see that all hardware and parts are present prior to start of assembly.
3. Please follow attached instructions in the same sequence as numbered to assure fast & easy assembly.

WARNING !



1. Don't attempt to repair or modify parts that are broken or defective. Please contact the store immediately.
2. This product is for home use only and not intended for commercial establishments.



ASSEMBLY TIME 20 MINUTES

PARTS IDENTIFICATION

A		BACK	1PC
B		ARM	1SETS
C		BASE	1PC
D		COVER	1PC
E		GAS LIFT	1PC
F		MECHANISM	1PC
G		CASTER	5PCS

HARDWARE IDENTIFICATION

1	WASHER	 M6*18MM*1.2	4PCS
2	SHORT SCREW	 M6*20MM	4PCS
3	LONG SCREW	 M8*50MM	4PCS
4	ALLEN KEY	 M6	1PC
5	ALLEN KEY	 M8	1PC

ASSEMBLY INSTRUCTIONS

STEP1

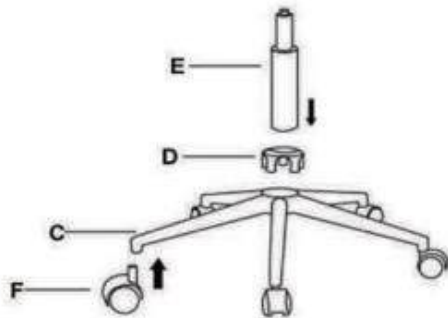

STEP2

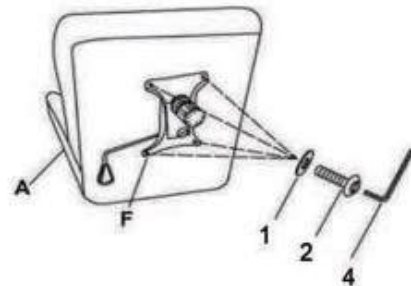

STEP3



STEP4

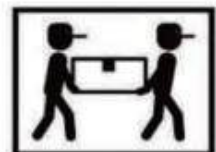

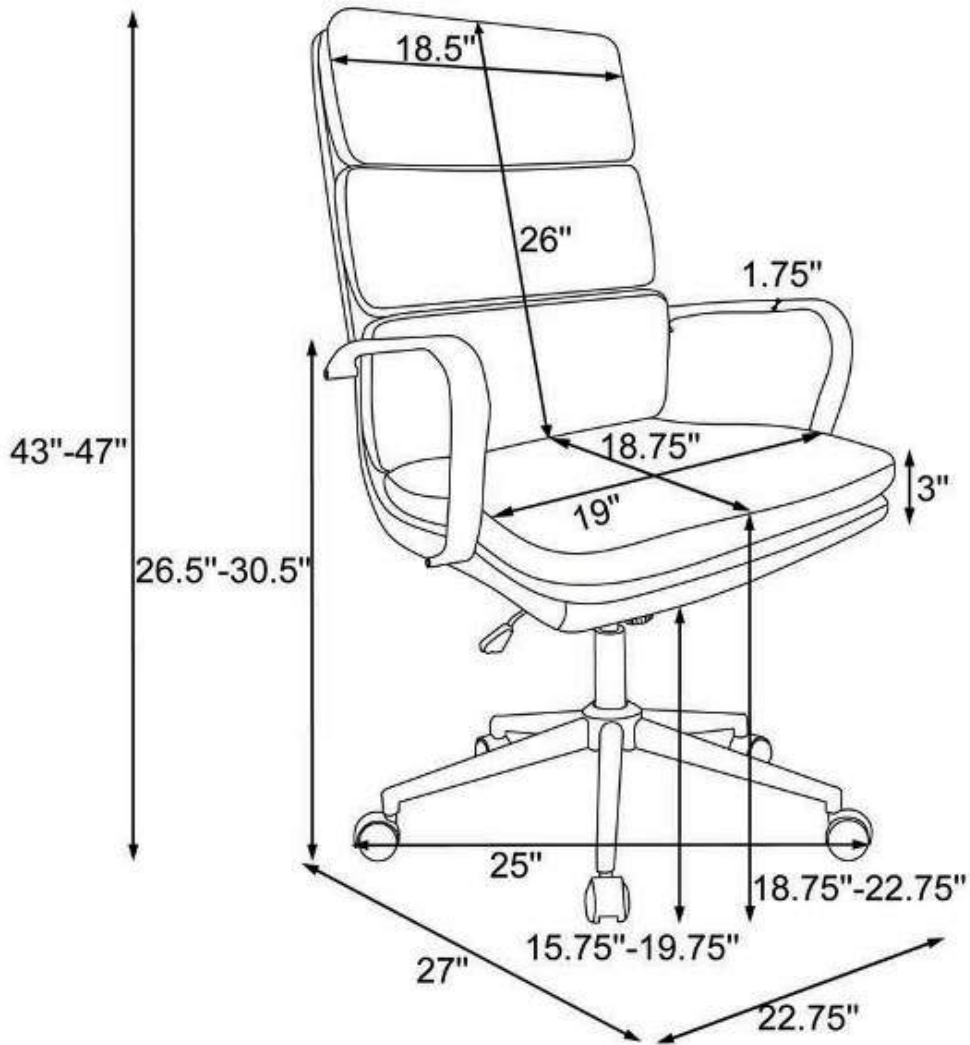

Note : Dimension tolerance $\pm 5\%$

Model, Quality : (Customer Information) (Product Information) (2021)

