

Assembly Instruction

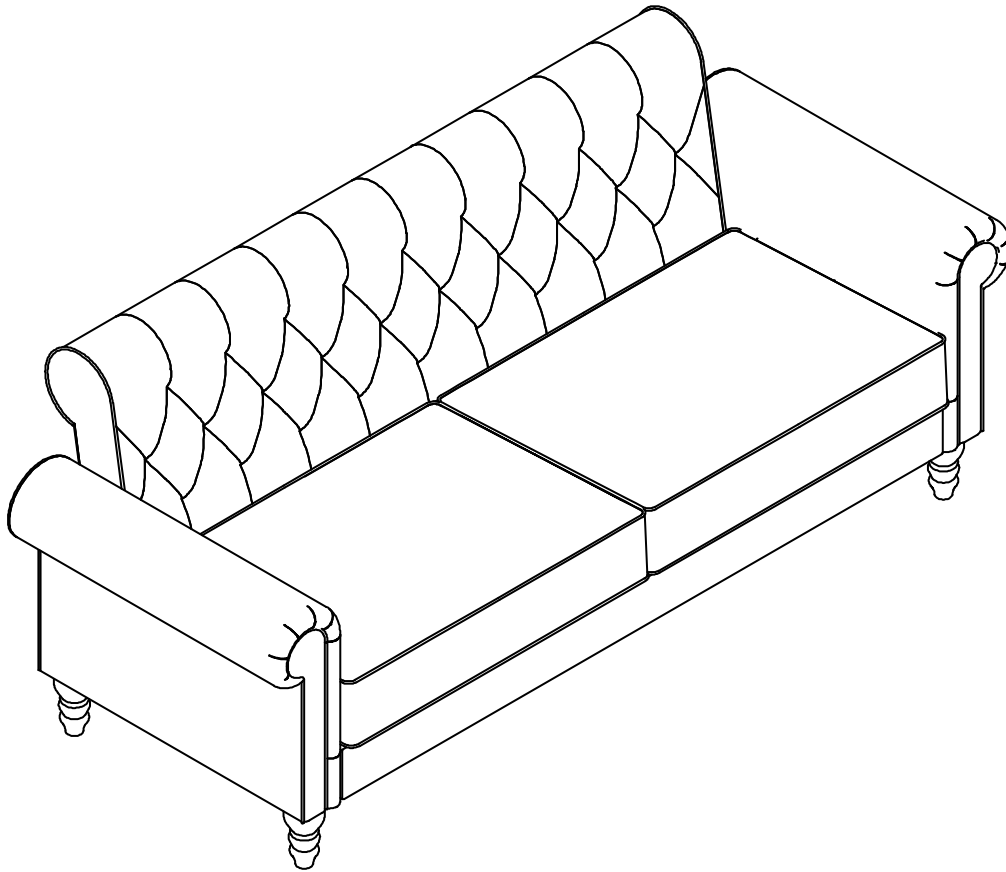

PART

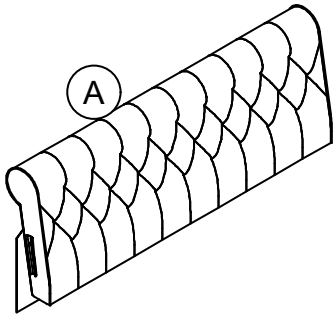

Back X 1 PC

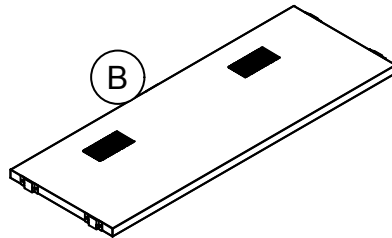

Seat Panel X 1 PC

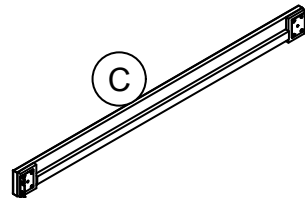

Front Rail X 1 PC

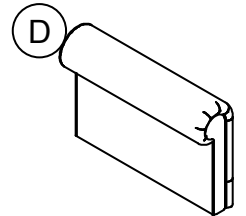

Armrest X 1 PC

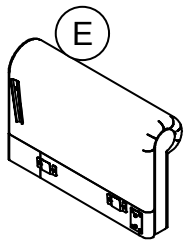

Armrest X 1 PC

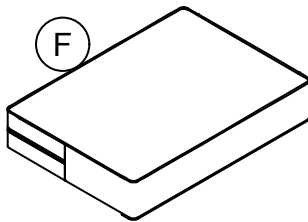

Seat Cushion X 2 PCS



Leg X 4 PCS



Support Leg X 1 PC

Place all parts on a clean, smooth surface.

STEP 1: Manually screw **G** x 4 to **D** & **E** with, as shown.

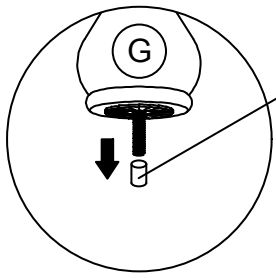

! Please remove the protective cap on the tip of thread before assembling.

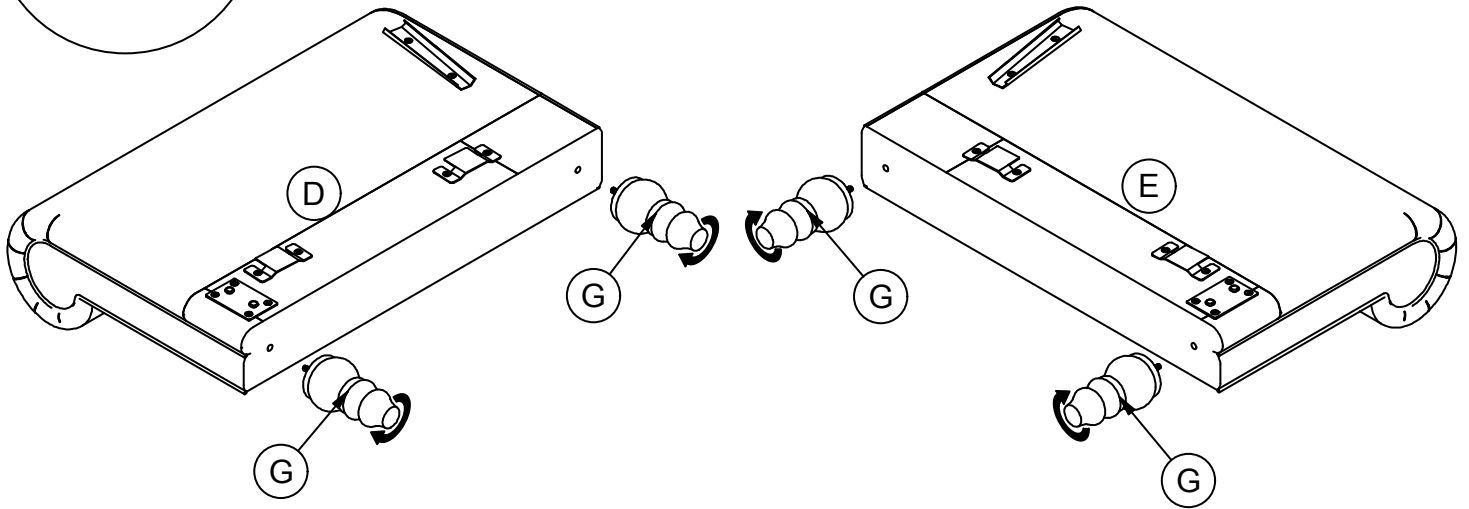

STEP 2: Attach **C** to **D** & **E** by inserting the brackets on **C** into the metal plate on **D** & **E**, as shown. Push **C** downwards to secure it into place.

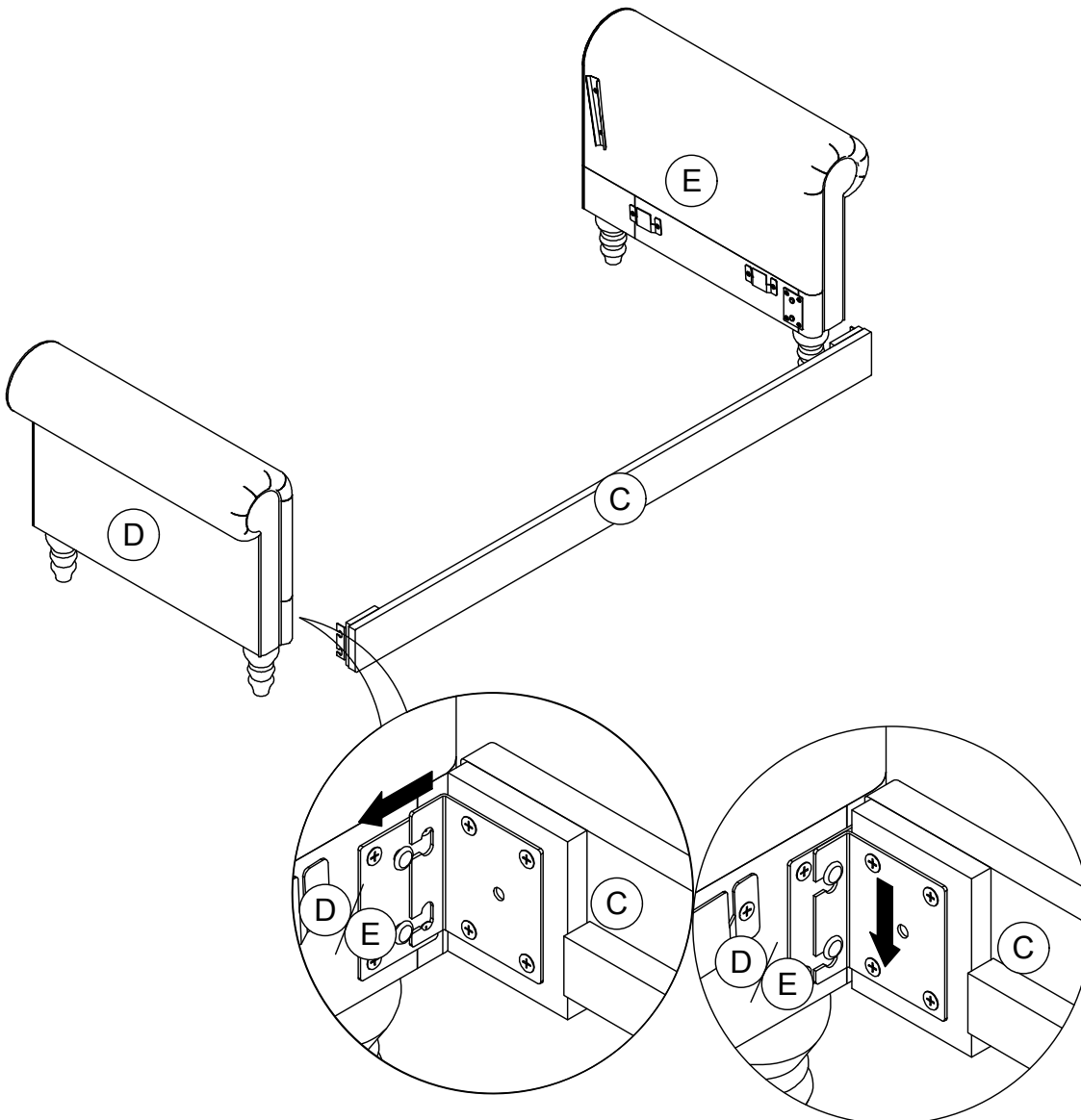

STEP 3: Manually screw **H** to **B**, as shown.

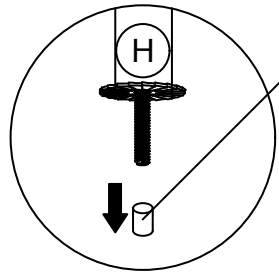

! Please remove the protective cap on the tip of thread before assembling.

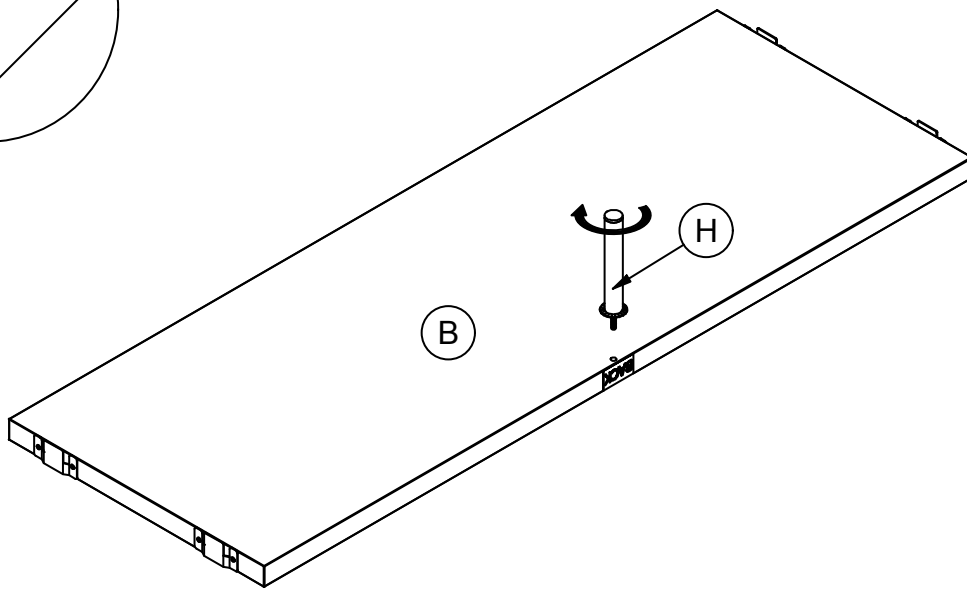

STEP 4: Attach **B** to **D** & **E** by inserting the metal brackets on **B** into the metal glides on **D** & **E**, as shown. Push **B** downwards to secure it into place.

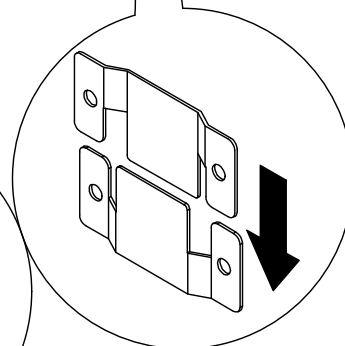
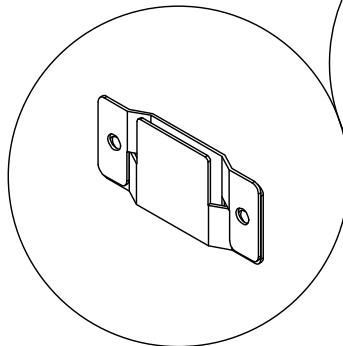
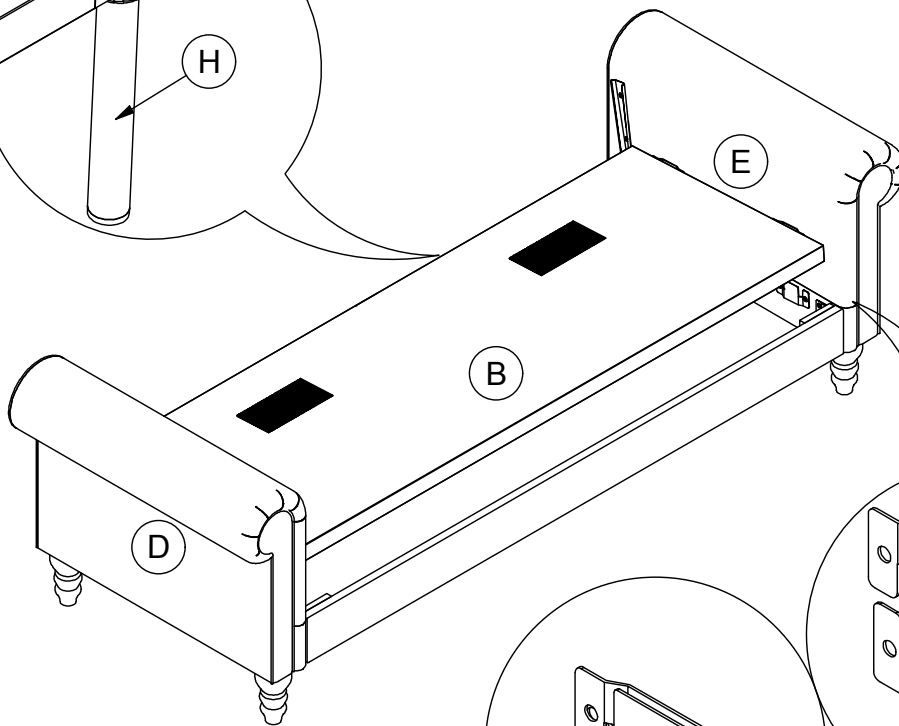
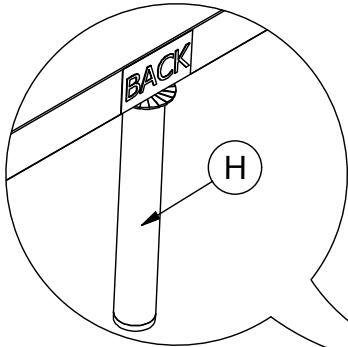

STEP 5:

5.1 Attach **A** to **D** & **E** by inserting the brackets on **A** into the metal glides on **D** & **E**.

Push **A** downwards to secure it into place.

5.2 Secure the fabric flap on **A** to **D** & **E** using the velcro strips.

⚠ Note: Both sides must be inserted at the same time. This step is best performed with 2 people.

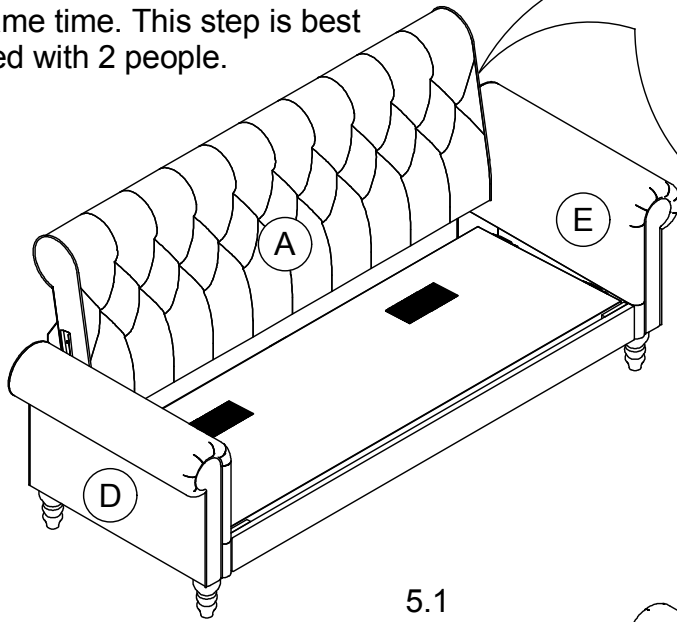

5.1

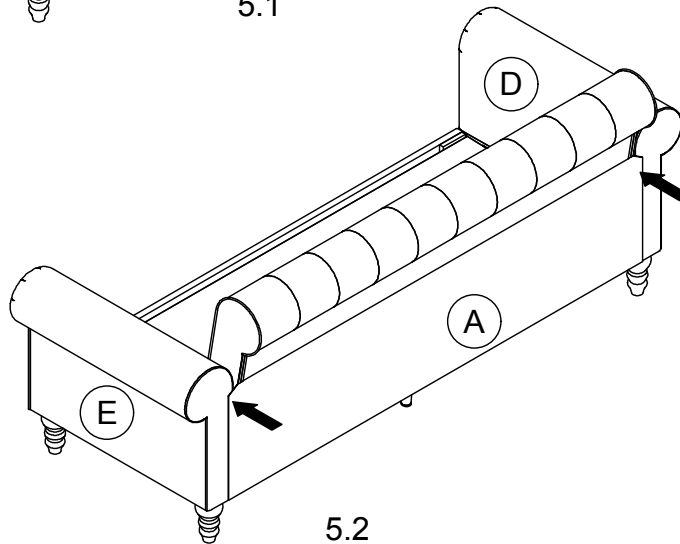

5.2

STEP 6: Place **F** x 2 onto the sofa using the velcro strips.

