

## **TV Stand**

**Assembly Instructions**

**Montageanleitung**

**Instrucciones de ensamblaje**

**Instructions de montage**

**Istruzioni di montaggio**



English

## WARNING!

Wipe clean with a damp cloth.

Wipe dry with a clean cloth.

Check regularly that all assembly fastenings are properly tightened and retighten when necessary.

Français

## ATTENTION!

Nettoyer à l'aide d'un chiffon humide.

Terminer en essuyant avec un chiffon sec.

Vérifiez régulièrement que toutes les fixations soient bien serrées et resserrez si nécessaire.

Deutsch

## ACHTUNG!

Mit einem feuchten Tuch abwischen.

Mit trockenem Tuch nachwischen.

Regelmäßig kontrollieren, dass alle Beschläge und Verschraubungen gut festgezogen sind und sie bei Bedarf nachziehen.

Italiano

## AVVERTENZA!

Pulisci con un panno umido.

Asciuga con un panno pulito.

Controlla regolarmente che tutti gli elementi di fissaggio siano stretti bene e, se necessario, serrali nuovamente.

Español

## ADVERTENCIA!

Limpiar con un paño húmedo.

Secar con un paño seco.

Comprueba regularmente que las fijaciones estén bien apretadas y vuelve a apretarlas en caso necesario.

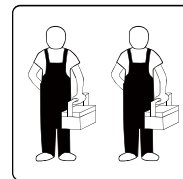

### **i** Tools Required :

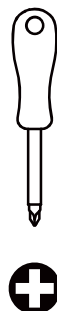
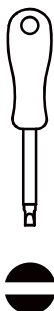



English

## **WARNING!**

1. When installing the product, use a soft surface (such as carpet or cardboard) to avoid scratching or damaging the surface of the product.
2. Please try to use a manual screwdriver instead of electric screw driver. A manual screwdriver can be used to better control the tightness of the screws.
3. Do not use any glue.
4. The product is unstable before it is assembled. Please pay attention to the product installation sequence, and align all screws and screw holes before tightening.
5. The structure of this product can not meet the requirements of children climbing.

Deutsch

## **ACHTUNG!**

1. Verwenden Sie bei der Montage des Produkts eine weiche Unterlage (z. B. Teppich oder Pappe), um Kratzer oder Beschädigungen auf der Oberfläche des Produkts zu vermeiden.
2. Bitte verwenden Sie nach Möglichkeit einen Schraubendreher von Hand anstelle eines elektrischen Schraubendrehers. Mit einem Handschraubendreher lässt sich die Festigkeit der Schrauben besser kontrollieren.
3. Verwenden Sie keinen Klebstoff.
4. Das Produkt ist vor der Montage instabil. Bitte beachten Sie die Montagereihenfolge des Produkts und richten Sie alle Schrauben und Schraublöcher aus, bevor Sie sie festziehen.
5. Die Konstruktion dieses Produkts ist nicht für das Klettern von Kindern ausgelegt.

Español

## **ADVERTENCIA!**

1. Al instalar el producto, utilice una superficie blanda (como alfombra o cartón) para evitar rayar o dañar la superficie del producto.
2. Utilice preferentemente un destornillador manual en lugar de uno eléctrico. Un destornillador manual permite controlar mejor el apriete de los tornillos.
3. No utilice ningún tipo de pegamento.
4. El producto es inestable antes de ser montado. Preste atención a la secuencia de instalación del producto y alinee todos los tornillos y agujeros antes de apretarlos.
5. La estructura de este producto no está diseñada para que los niños trepen por él.

Français

## **ATTENTION!**

1. Lors de l'installation du produit, utilisez une surface molle (comme un tapis ou du carton) pour éviter de rayer ou d'endommager la surface du produit.
2. Veuillez essayer d'utiliser un tournevis manuel plutôt qu'un tournevis électrique. Un tournevis manuel permet de mieux contrôler le serrage des vis.
3. N'utilisez aucune colle.
4. Le produit est instable avant son assemblage. Veuillez respecter l'ordre d'installation du produit et alignez toutes les vis et tous les trous avant de serrer.
5. La structure de ce produit n'est pas conçue pour supporter que des enfants grimpent dessus.

Italiano

## **AVVERTENZA!**

1. Durante l'installazione del prodotto, utilizzare una superficie morbida (come un tappeto o del cartone) per evitare di graffiare o danneggiare la superficie del prodotto.
2. Si prega di utilizzare un cacciavite manuale invece di un cacciavite elettrico. Un cacciavite manuale permette di controllare meglio la tensione delle viti.
3. Non utilizzare alcun tipo di colla.
4. Il prodotto è instabile prima del montaggio. Prestare attenzione alla sequenza di installazione del prodotto e allineare tutte le viti e i fori delle viti prima di serrarli.
5. La struttura di questo prodotto non è adatta per sopportare il peso di bambini che ci si arrampicano.

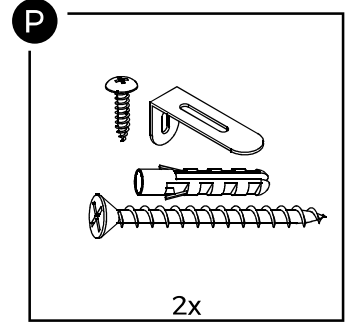
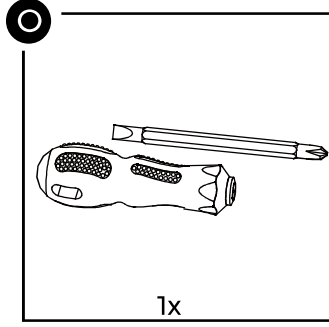
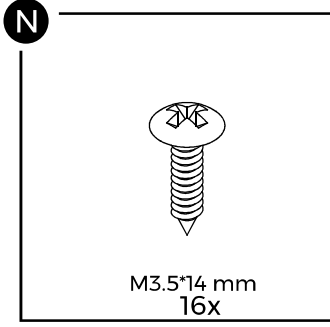
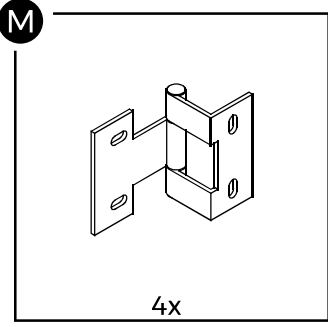
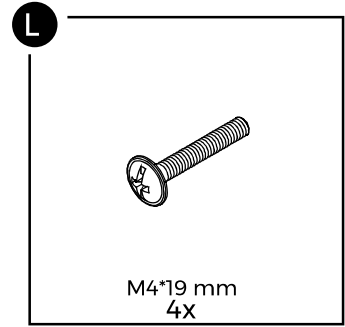
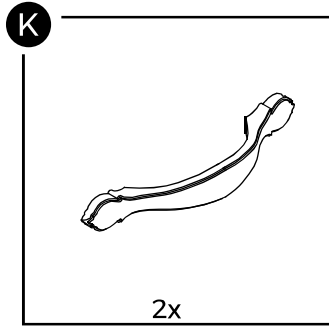
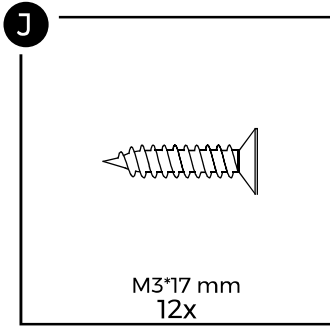
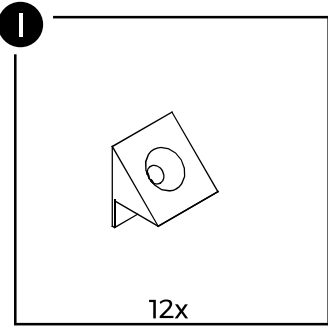
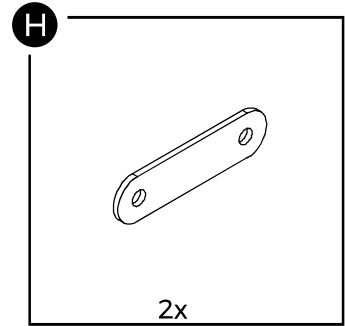
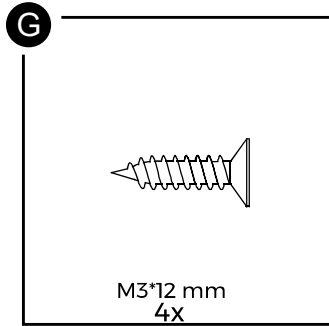
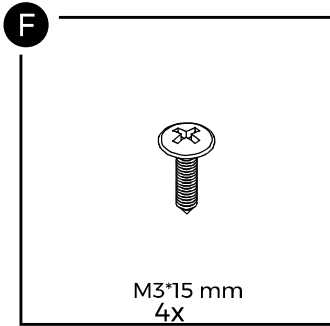
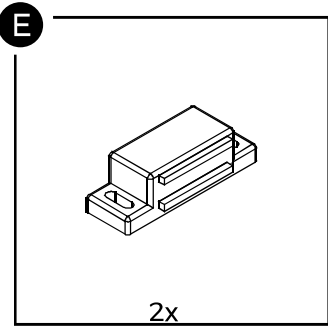
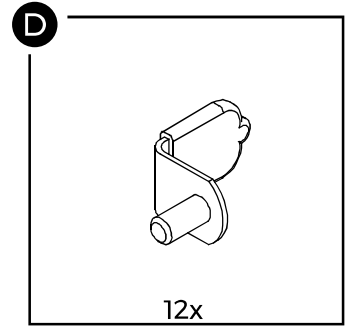
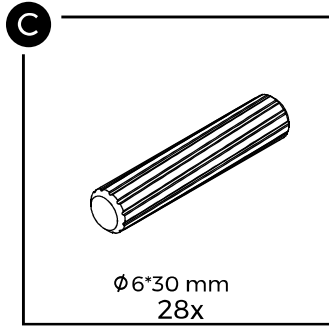
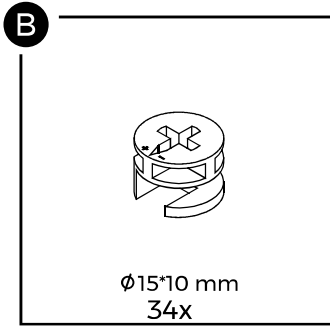
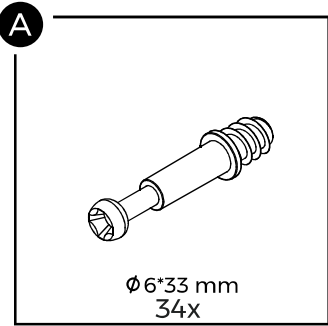

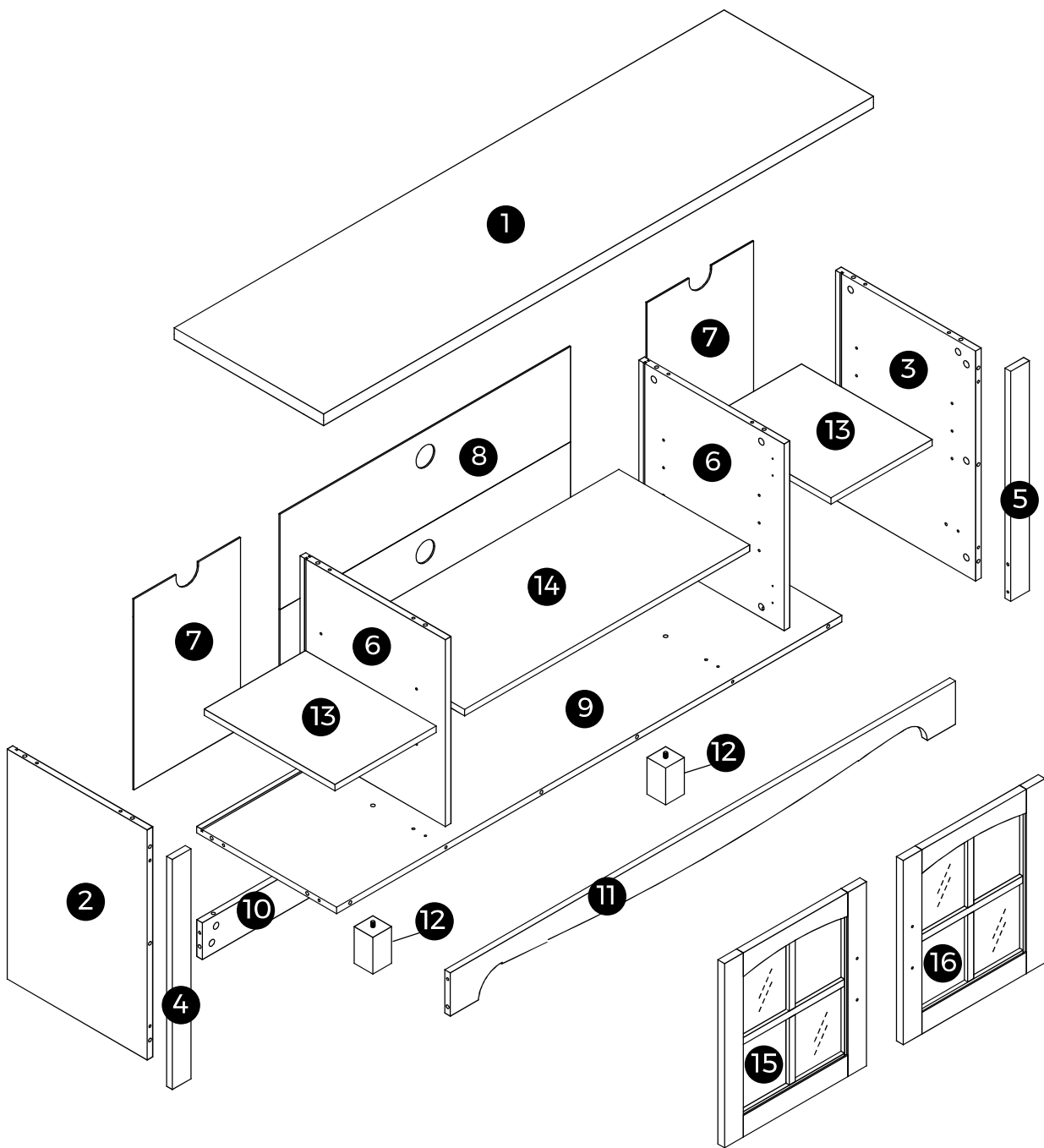
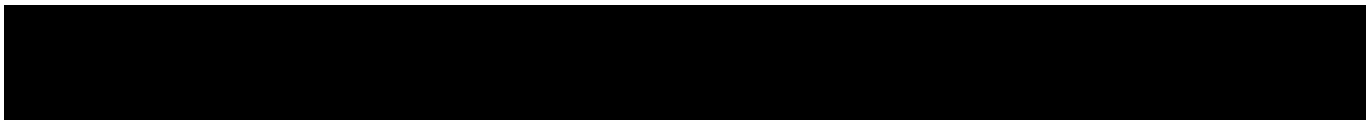



# 1

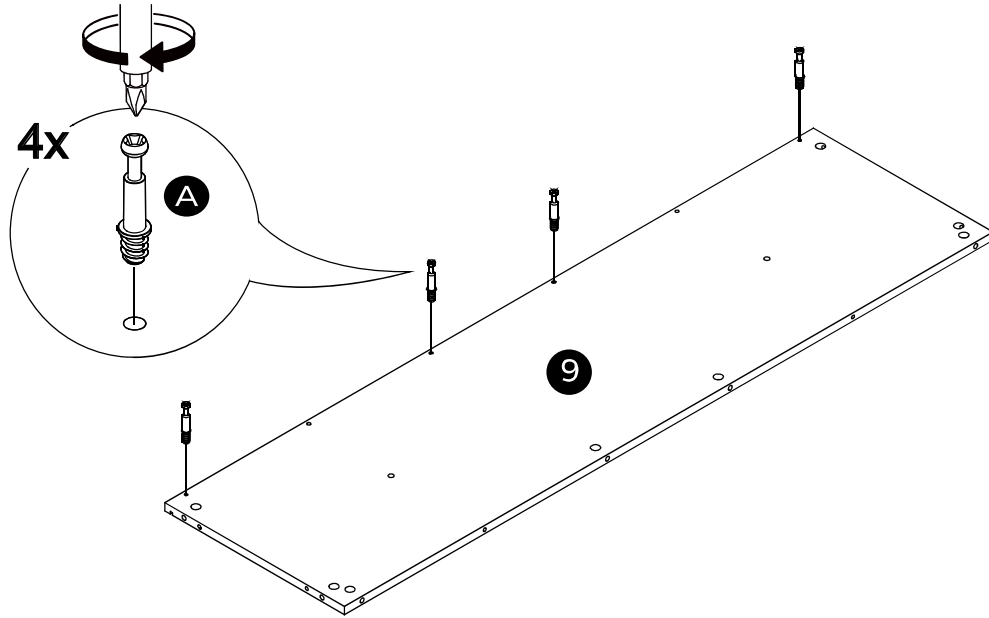

# 2

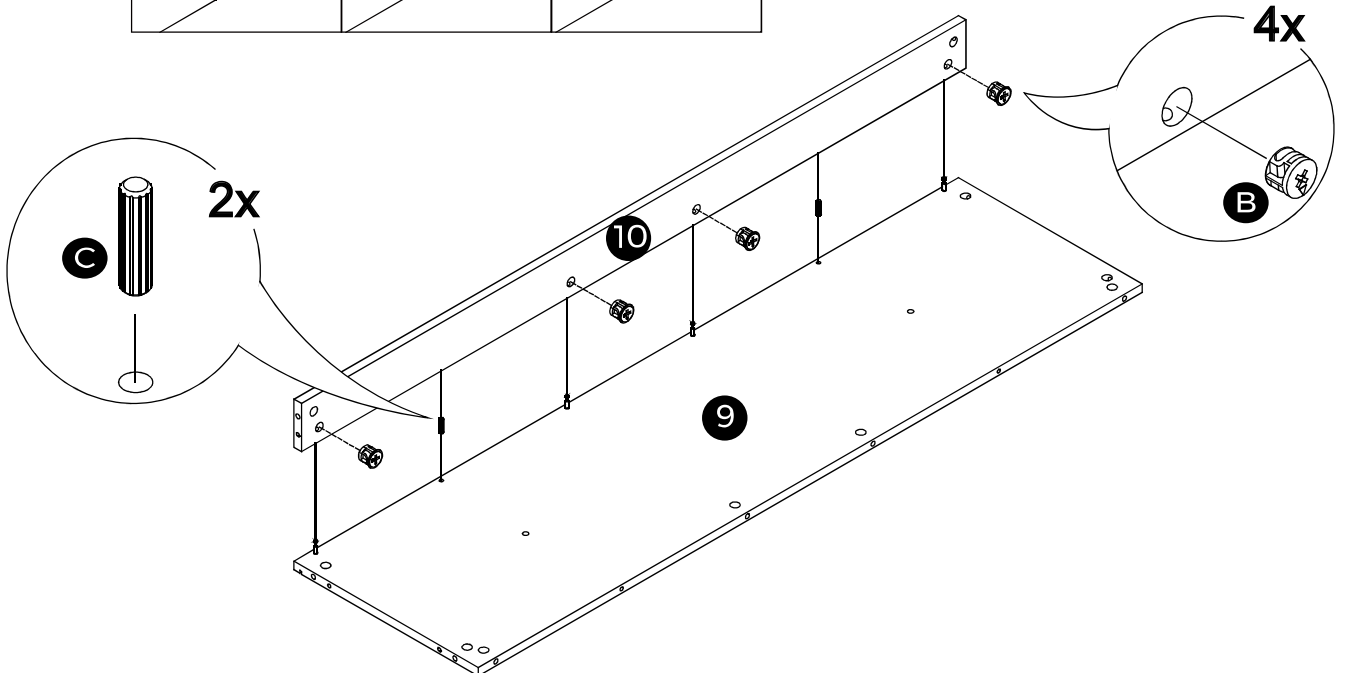
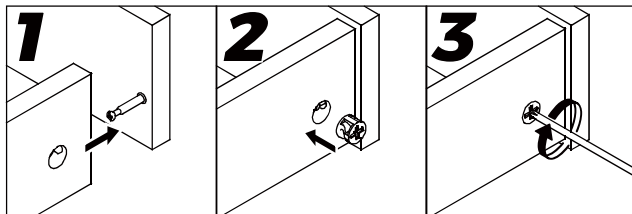

**3**

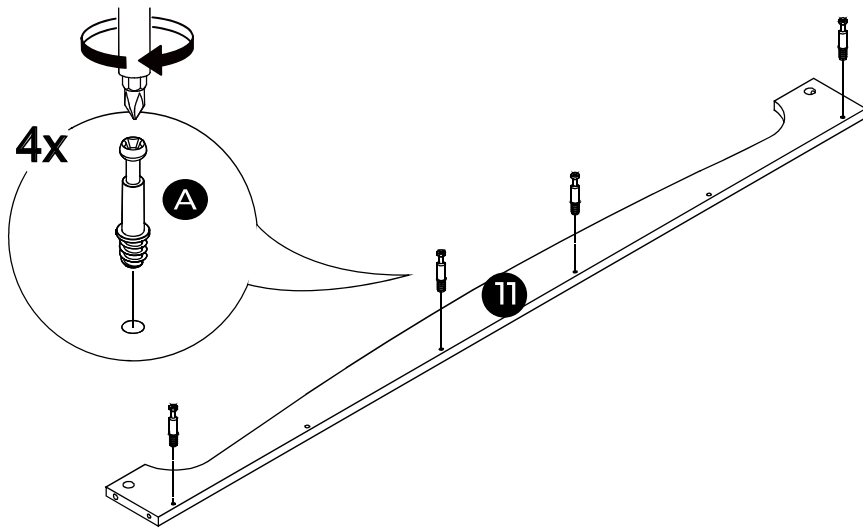

**4**

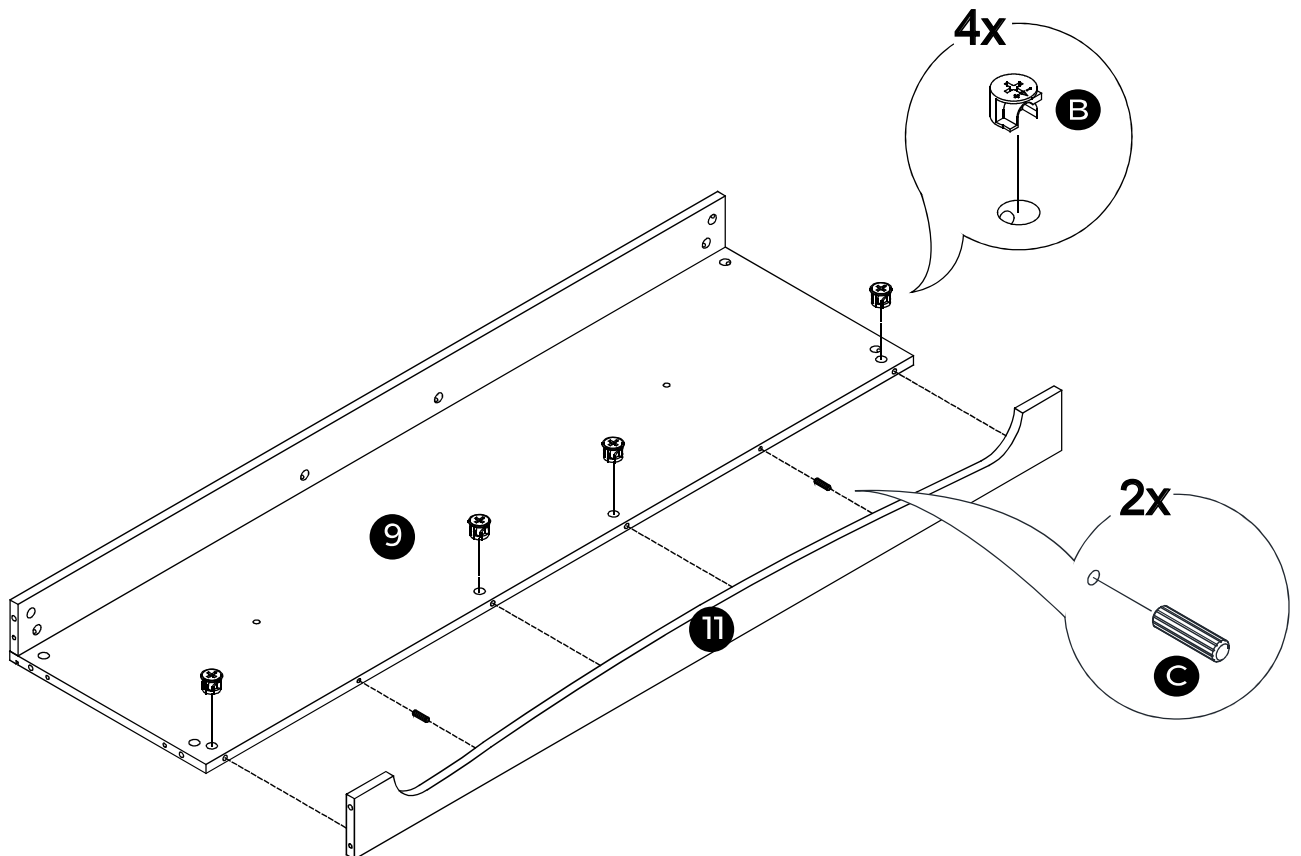

**5**

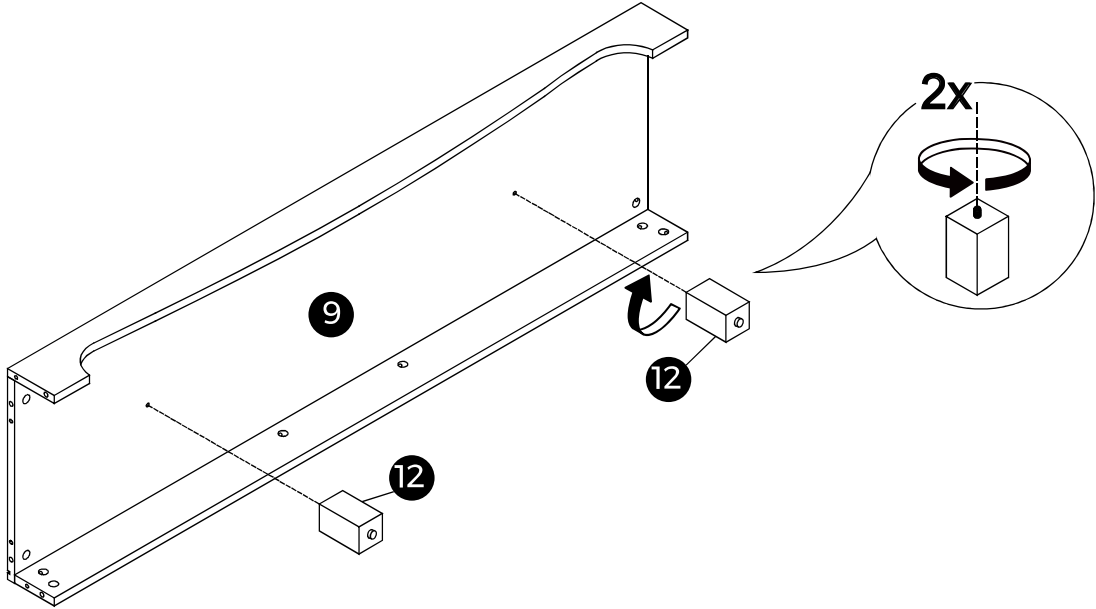

**6**

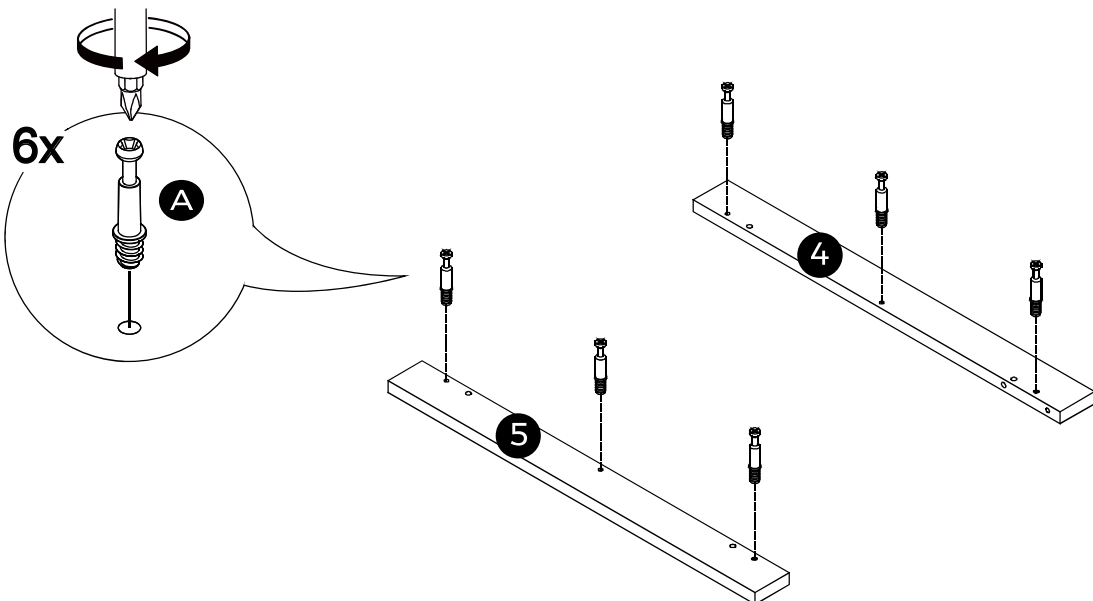

# 7

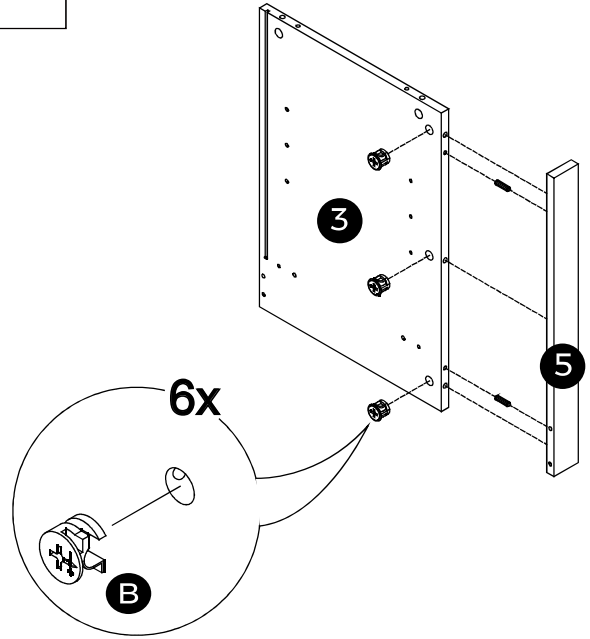
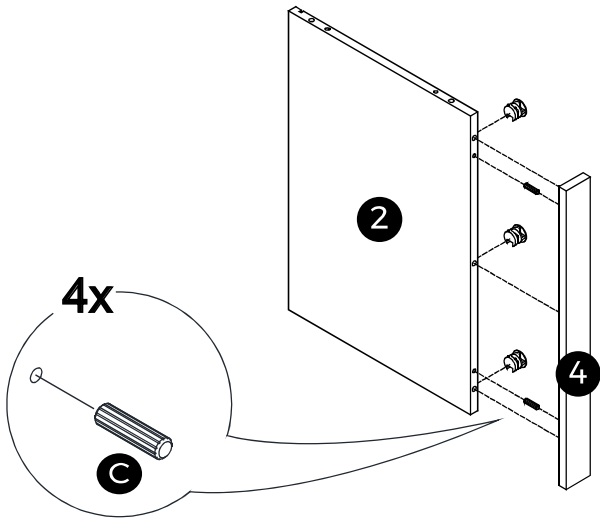
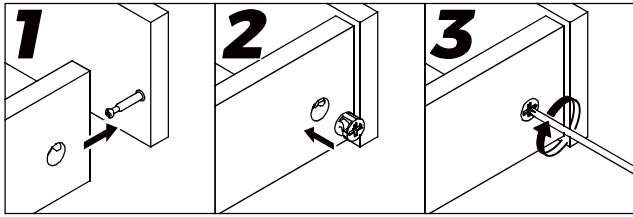

# 8

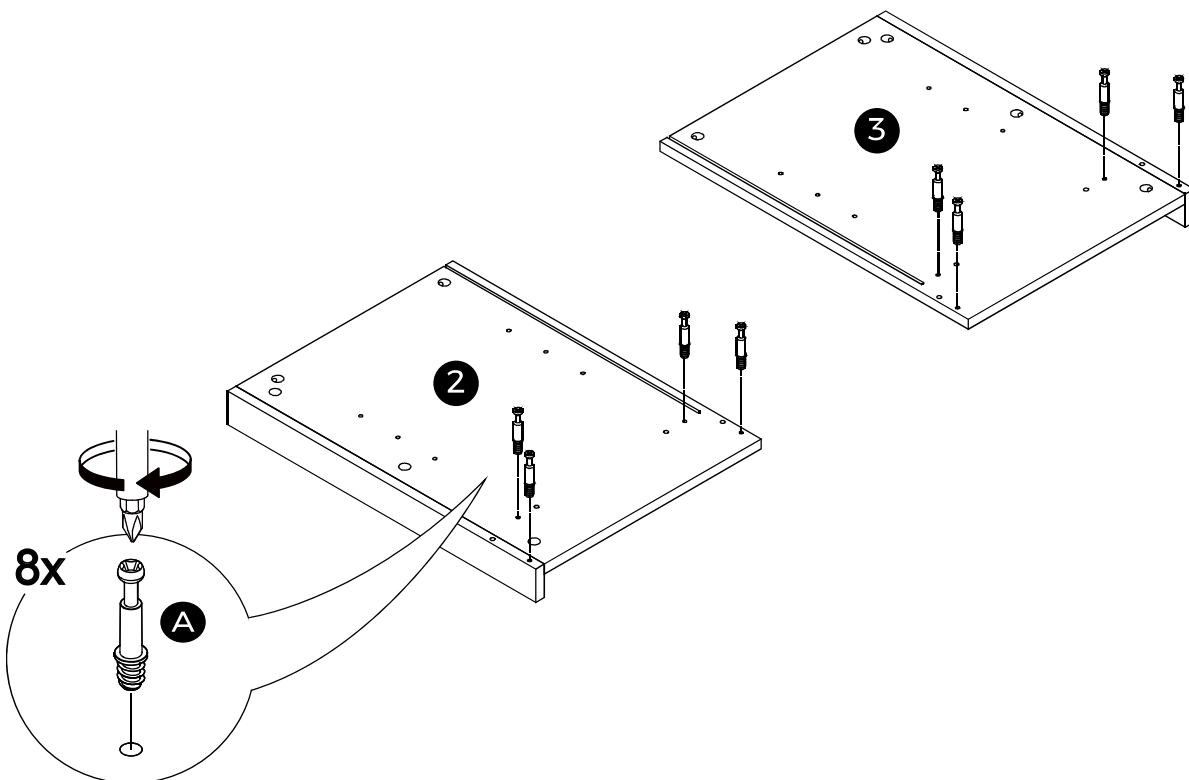

9

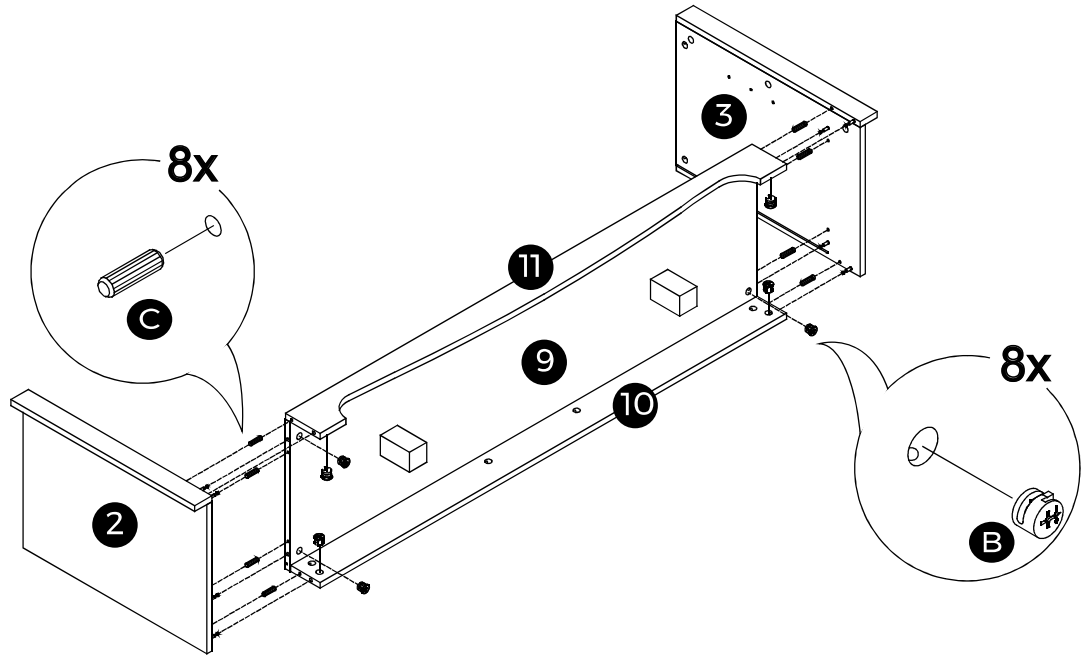

10

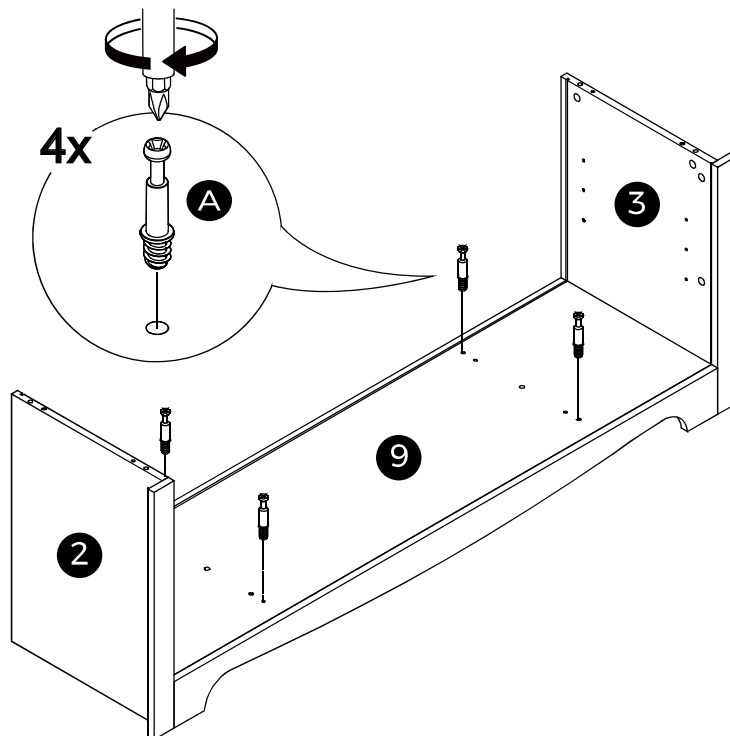

**11**

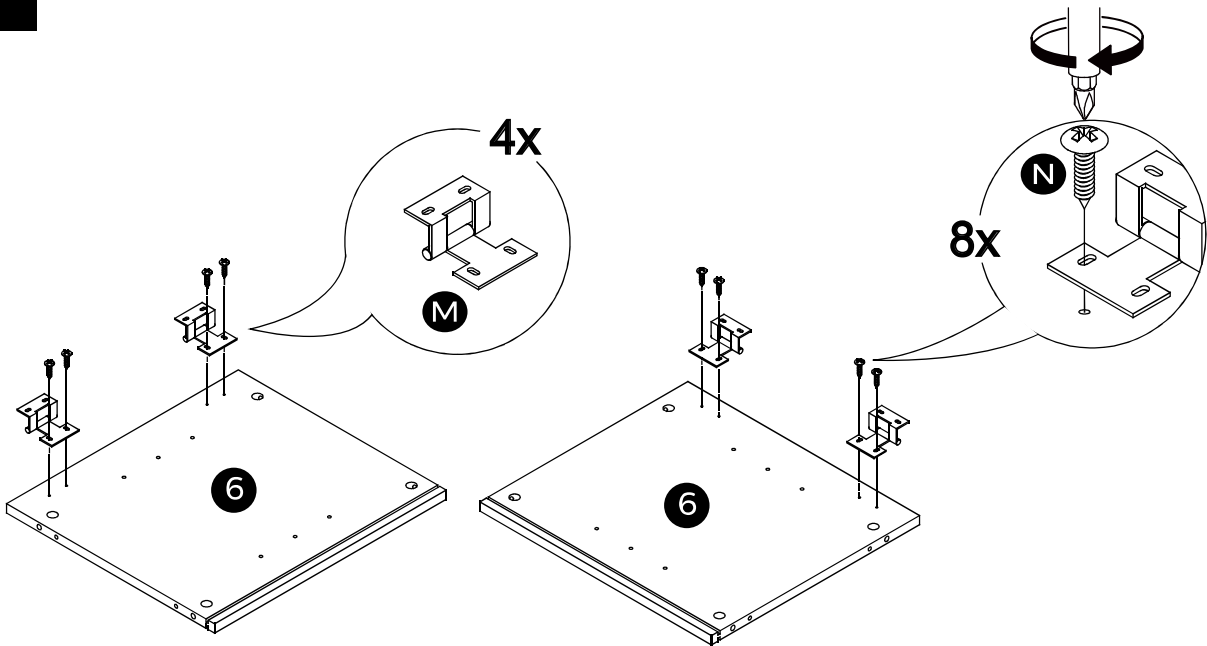

**12**

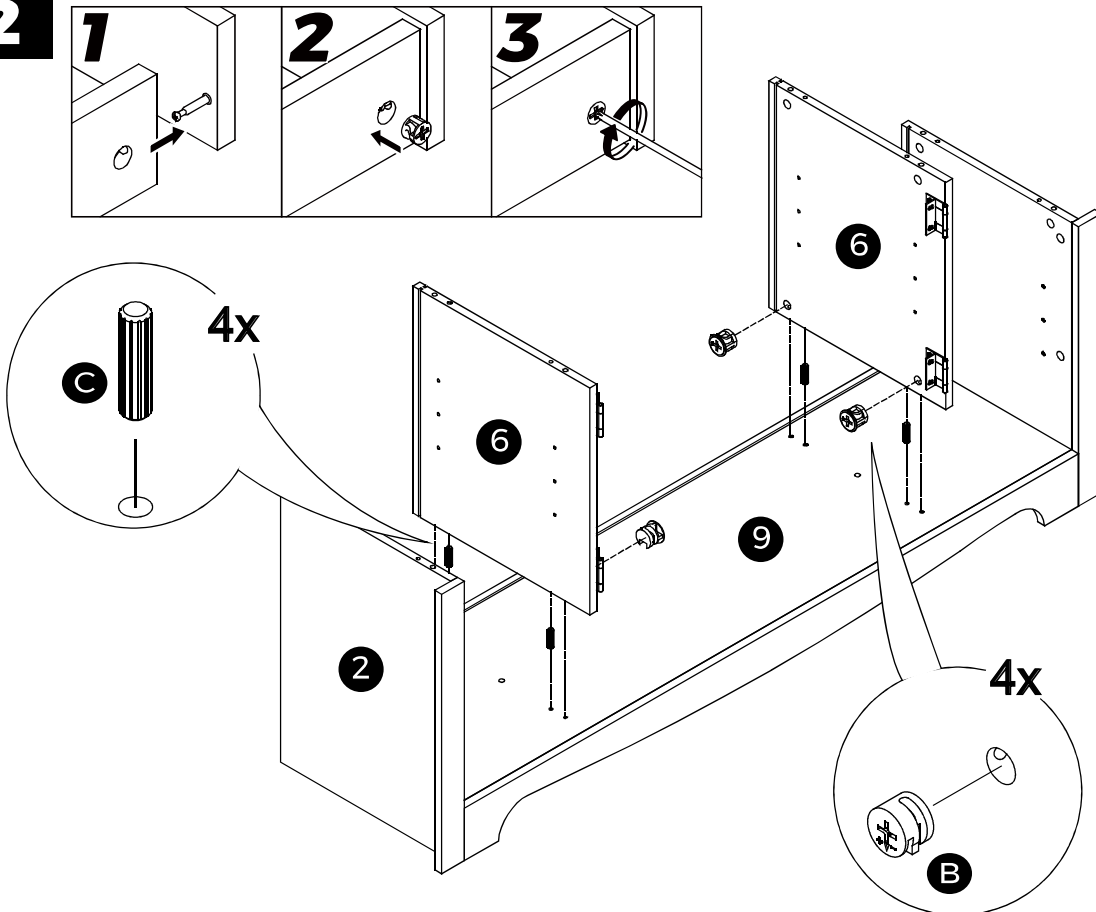

# 13

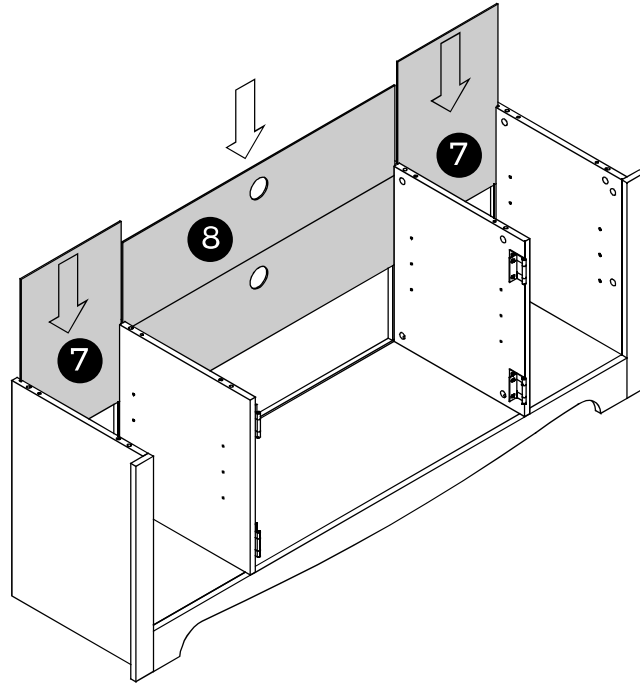

# 14

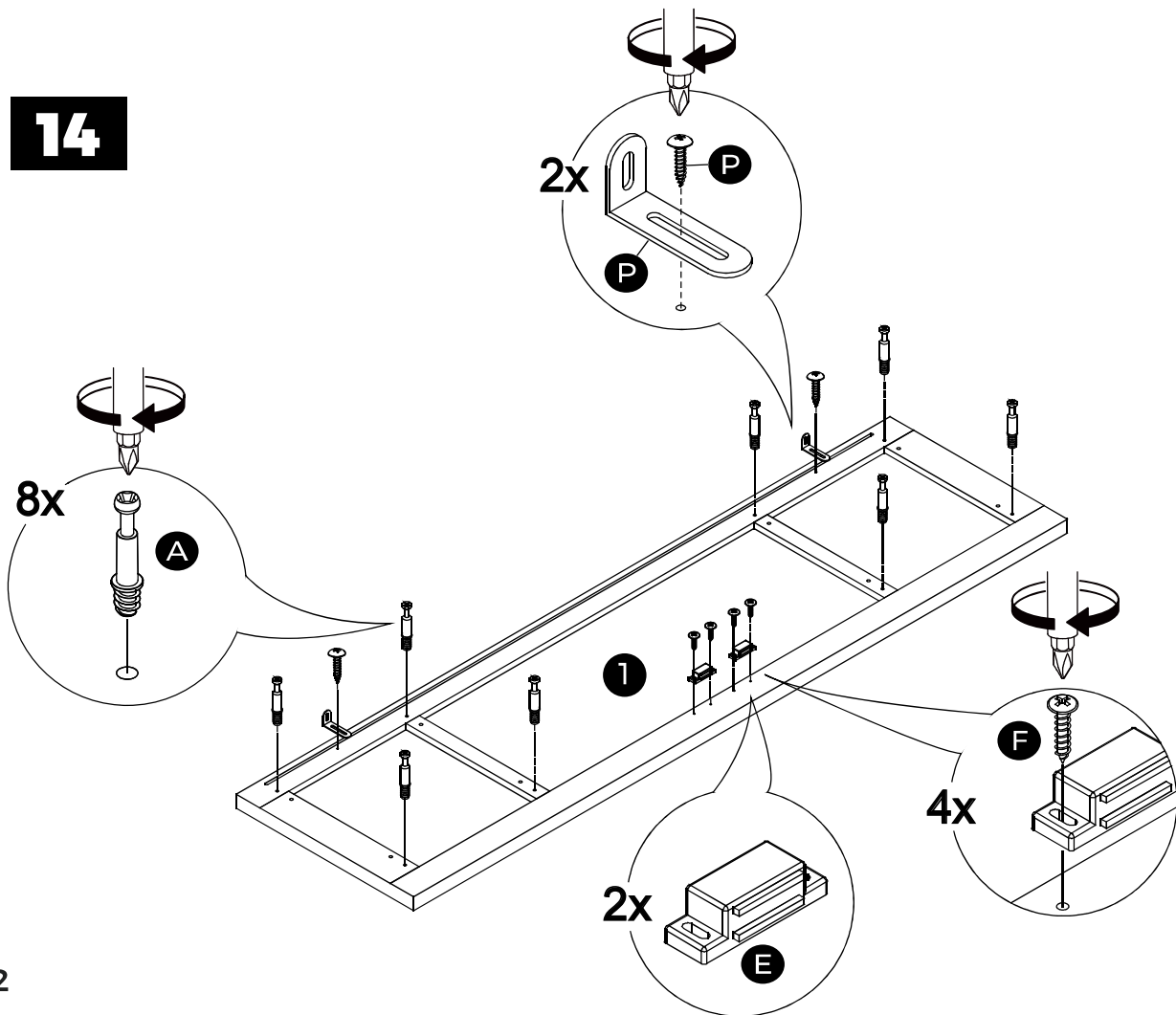

**15**

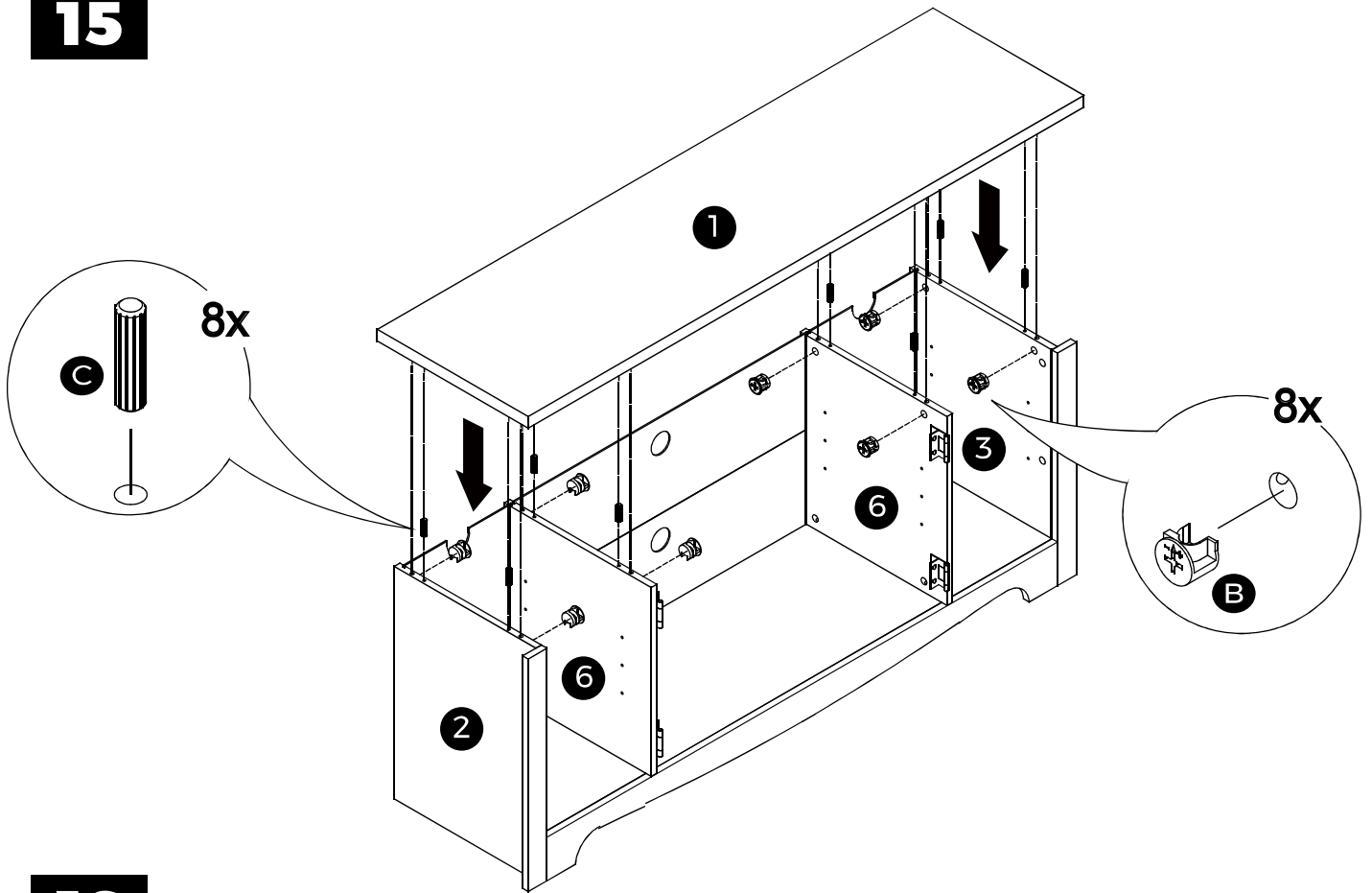

**16**

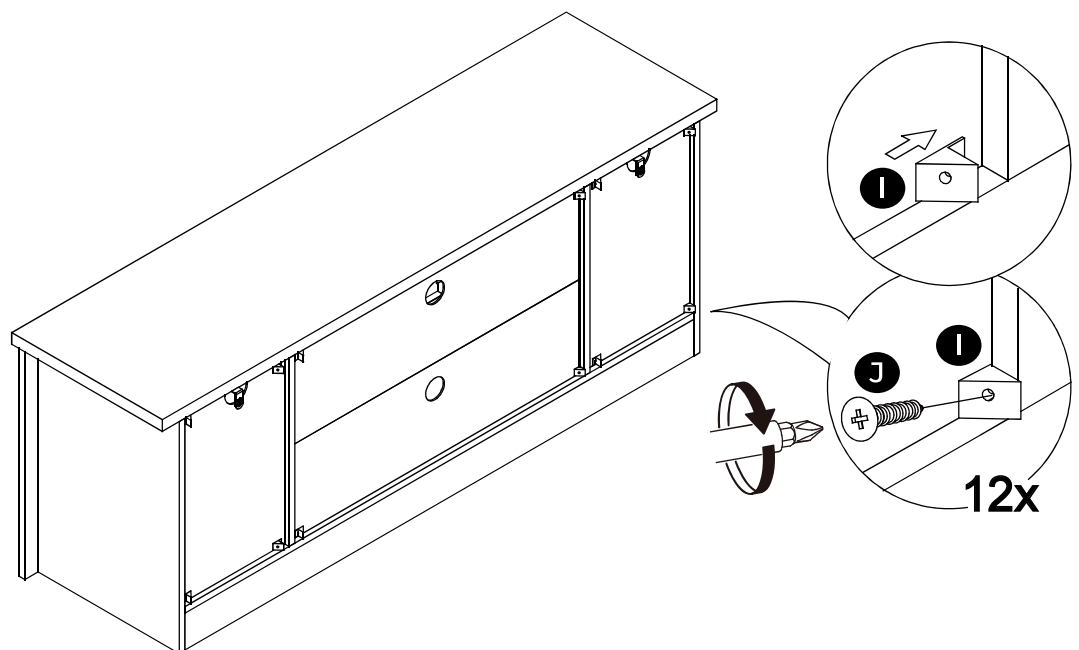

**17**

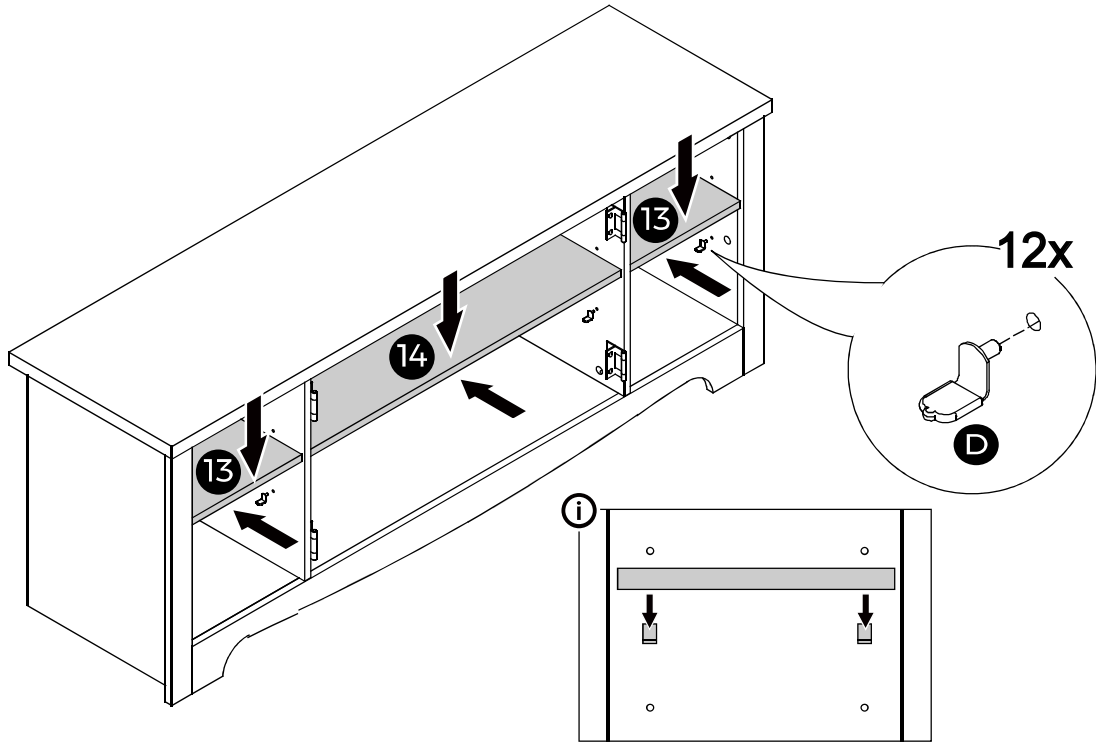

**18**

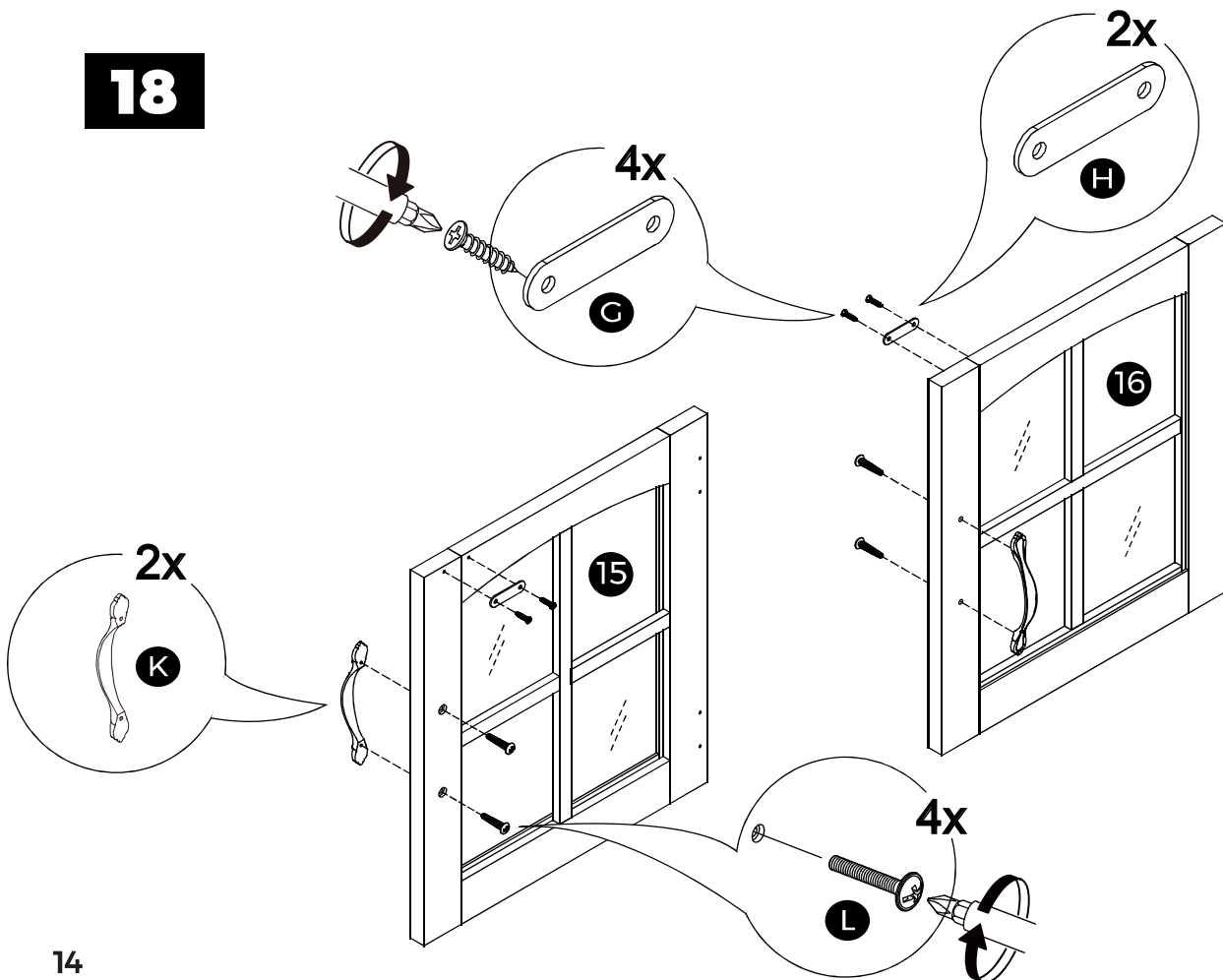

**19**

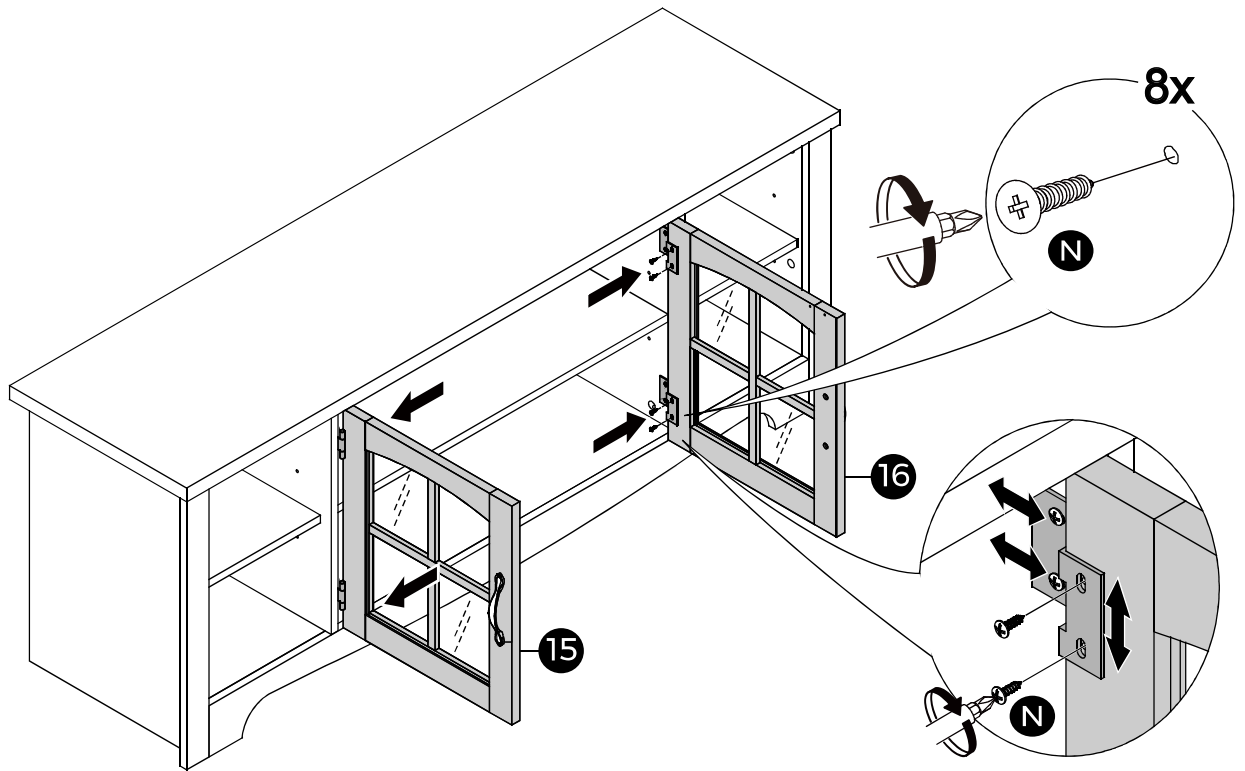

When installing the door panels, you may need to adjust the fittings according to the diagram to ensure the proper opening and closing of the door panels.

**20**

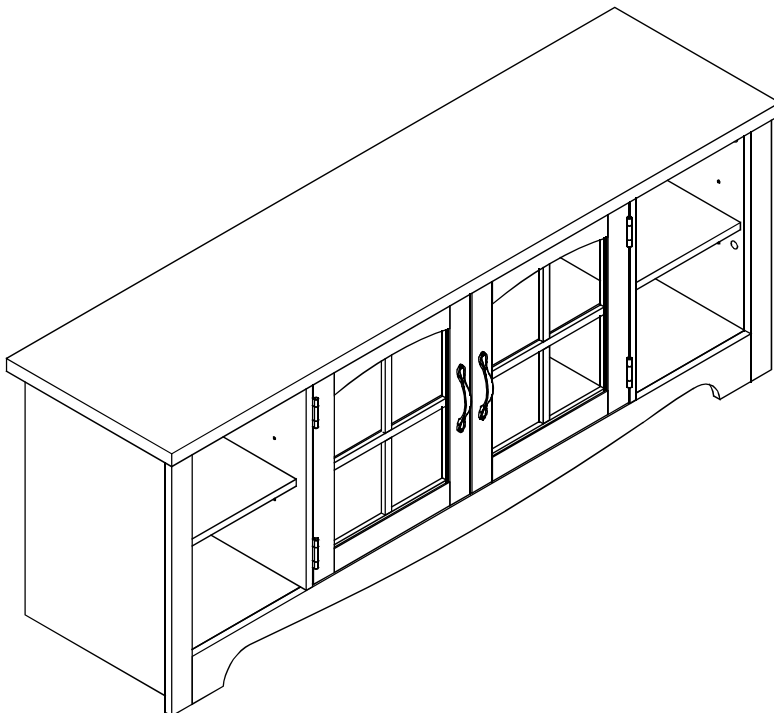

### English

The screw and plug supplied can be used with most solid (A) and hollow (B) walls. For solidwood (C) use the screw without plug. If you are uncertain, please seek professional advice.

### Deutsch

Das beigelegte Befestigungsmaterial kann für die meisten Massiv- (A) und Hohlwände (B) benutzt werden. Für Massivholzuntergrund (C) Schraube/n ohne Dübel verwenden. Bei Unsicherheit immer fachlichen Rat einholen.

### Español







Los tornillos y tacos incluidos se pueden utilizar en la mayor parte de las paredes sólidas (A) o huecas (B). Para la madera maciza (C), usa los tornillos sin tacos. Si tienes dudas, acude a un experto.

### Français

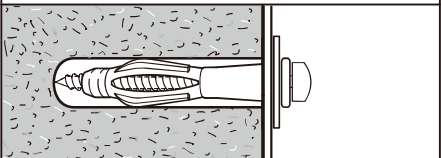
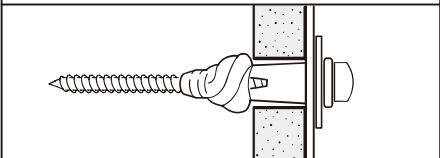
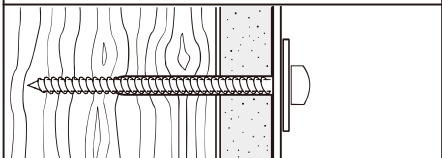
Les vis et les chevilles fournies peuvent être utilisées avec la plupart des murs pleins (A) ou des murs creux (B). Pour le bois massif (C), utiliser les vis sans les chevilles. En cas de doute, adressez-vous à un professionnel qualifié.

### Italiano

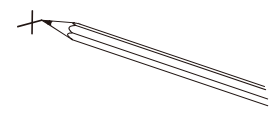
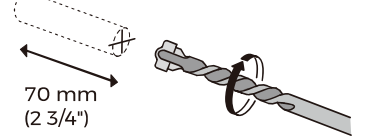
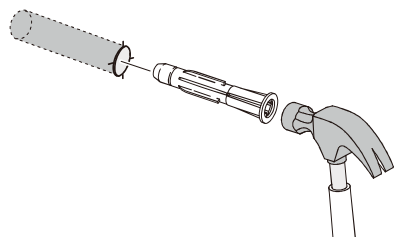
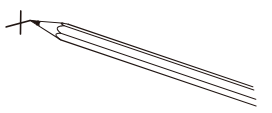
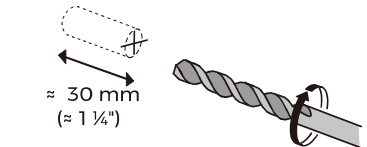
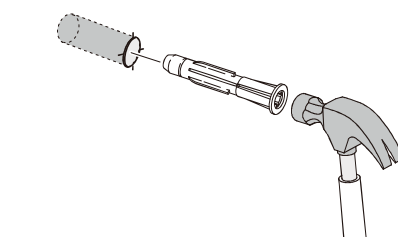
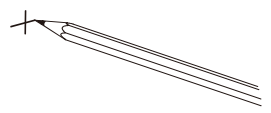
Le viti e i tasselli forniti sono utilizzabili con la maggior parte delle pareti piene (A) e cave (B). Per il legno massiccio (C), usa le viti senza i tasselli. Se hai dubbi, rivolgiti a un esperto.

A	B	C
		
Ø 6 mm (15/64") 	Ø 6 mm (15/64") 	Ø 3 mm (1/8") 
<p><b>1</b> </p> <p><b>2</b>  70 mm (2 3/4")</p> <p><b>3</b> </p>	<p><b>1</b> </p> <p><b>2</b>  ≈ 30 mm (≈ 1 1/4")</p> <p><b>3</b> </p>	<p><b>1</b> </p> <p><b>2</b>  ≈ 30 mm (≈ 1 1/4")</p> <p><b>3</b> </p>

**21**

**WARNING** In order to prevent overturning this product must be used with the wall attachment device provided.

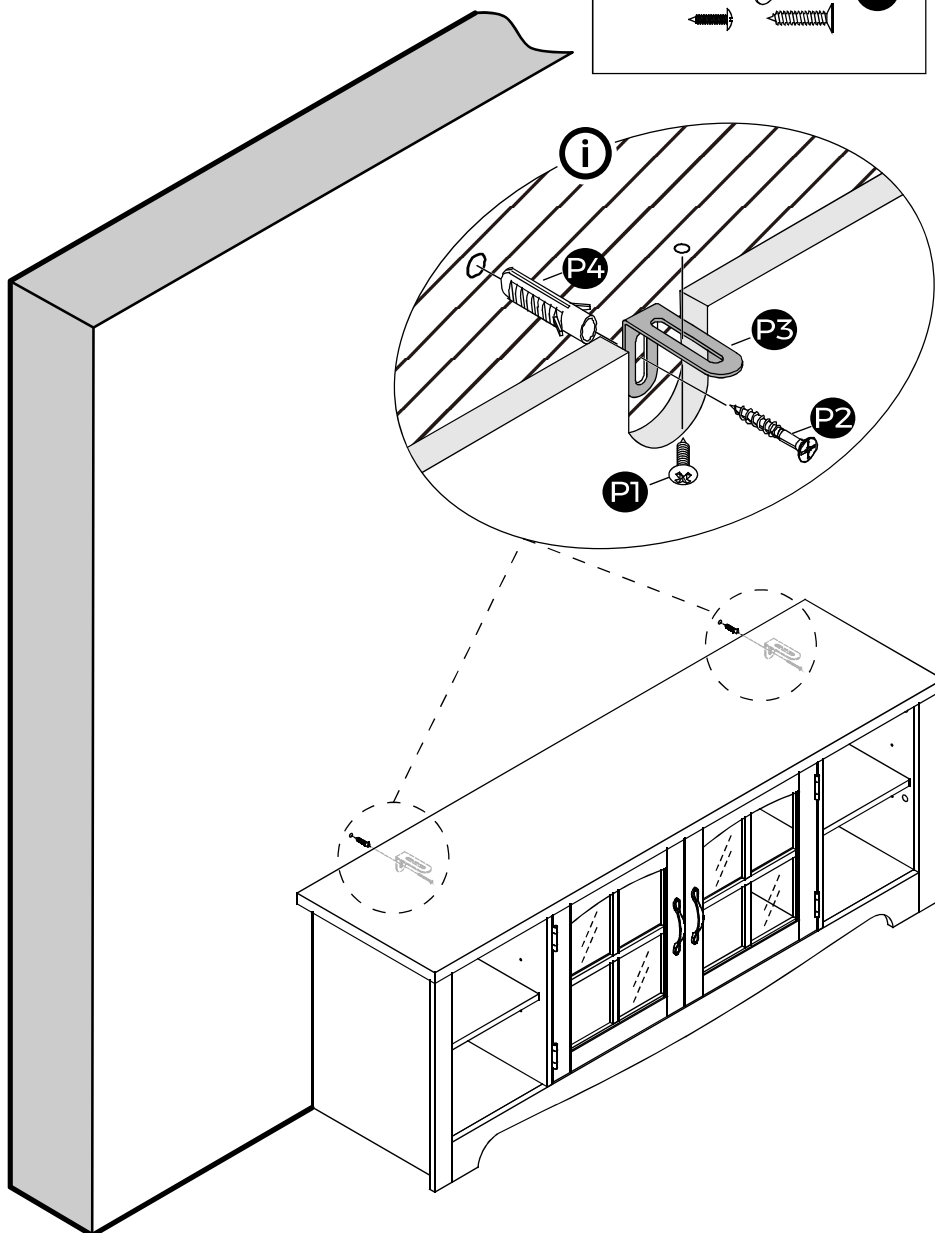
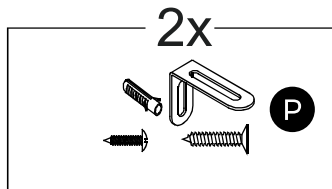

Step 1: Determine the location of the anti-overturning on the wall and then mark the position after confirming the product has been balanced.

Step 2: Drill the hole on the wall.

Step 3: Use a hammer to fixed the anchor (P4) on the wall.

Step 4: Use screw (P1) to fix the anti-overturnig(P3) on the top panel.

Step 5: Use screw (P2) to fix the anti-overturnig(P3) on the wall.

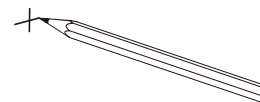
**1****WALL**

Mark the hole drilling location

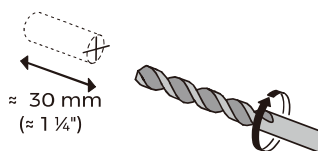
**2****WALL**

Drill hole

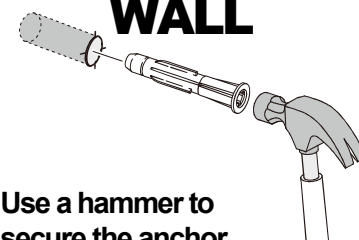
**3****WALL**

Use a hammer to secure the anchor

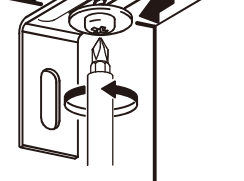
**4****PANEL**

Secure to the top panel

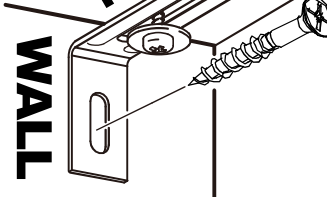
**5****PANEL**

Secure to the wall