

DINING CHAIR

ASSEMBLY GUIDE

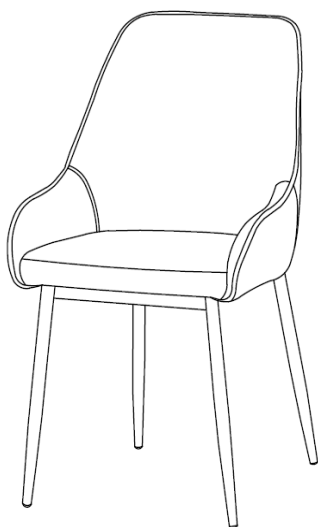

Important - Please read these instructions fully before starting assembly



**SAFETY AND
CARE ADVICE**



NO POWER TOOLS

SAFETY AND CARE ADVICE

- Check you have all the components and tools listed.
- Remove all fittings from the plastic bags and separate them into their groups.
- We do not recommend the use of power drills/drivers for inserting screws, as this could damage the unit. Only use hand screwdrivers and Allen keys.
- Keep children and animals away from the work area, small parts could cause choking if swallowed.
- Make sure you have enough space to lay out the parts before starting.
- Assemble the item as close to its final position (in the same room) as possible.
- Do not over tighten the nuts to avoid causing damage to the threads.
- Only clean using a damp cloth and mild detergent, do not use bleach or abrasive cleaners.
- From time to time check that there are no loose screws on this unit
- This product should not be discarded with household waste. Take to your local authority waste disposal centre

IMPORTANT INFORMATION



30 MINUTE
BUILD



ONE
PERSON



MAXIMUM
CAPACITY
120Kg

PLEASE CHECK CAREFULLY AND MAKE SURE YOU HAVE ALL FITTINGS AND TOOLS LISTED BELOW BEFORE YOU START.

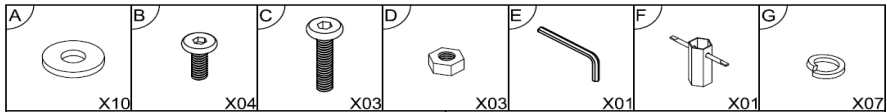

NOTE: The quantities above are the correct amount to complete the assembly. In some cases more fittings may be supplied than are required.

STEP 1

Carefully align the front and back legs together and secure with 3x washers [A] followed by 3x screws [C] and tighten with allen key [E]. Use spanner [F] to tighten washers [A + G] + Bolt [D] to the corresponding side.

NOTE: Be careful not to fully tighten fixings at this stage

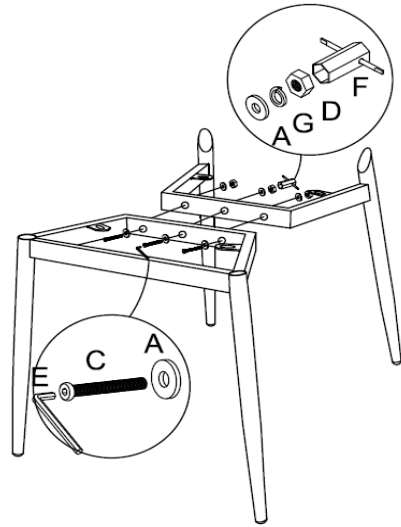

STEP 2

Place the leg frame on a flat surface. Ensure the legs are level and tighten the fixings each side with allen key [E] and spanner [F].

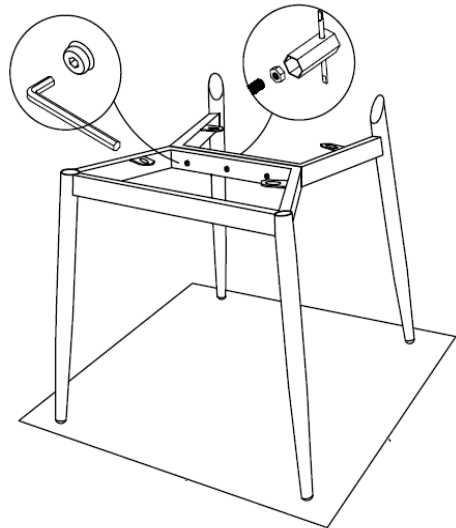

STEP 3

Place the seat pad upside down on a clean, flat, soft surface to avoid any bumps or scratches. I.e., Kitchen top.

Align the leg frame with the pre-drilled holes on the seat pad and secure with 4x washers [A + G] followed by 4x screw [B]. Tighten with allen key [E]

NOTE: The leg frame is shaped. The pointed legs should align with the back rest

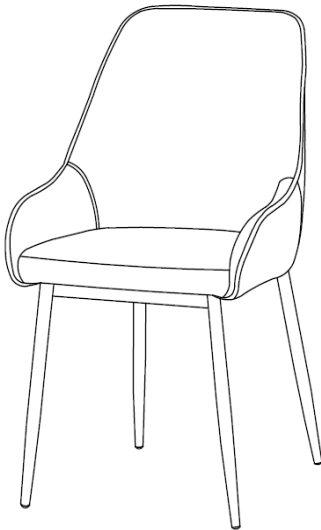
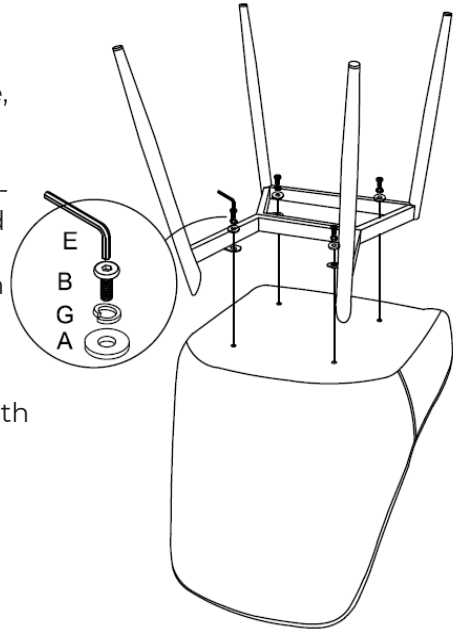

STEP 4

Carefully flip your chair so it stands on its feet. Check stability. Your chair is now ready to use!



OUR 2 YEAR GUARANTEE

our products come with a 1 year guarantee to give you peace of mind shopping



WHAT THE GUARANTEE COVERS



PRE-INSERTED FIXINGS
e.g. loose metal threads



FAULTY JOINTS
e.g. legs bending



EXTERNAL FIXING FAULTS
e.g. metal discs removing from table top



STRUCTURAL INTEGRITY
e.g. the frame of the product