

# *ASSEMBLY INSTRUCTIONS*



## ***SHOE CABINET***

# ASSEMBLY INSTRUCTIONS

## ASSEMBLY TIPS:

1. Remove hardware from box and sort by size.
2. Please check to see that all hardware and parts are present prior to start of assembly.
3. Please follow attached instructions in the same sequence as numbered to assure fast & easy assembly.



### WARNING!

1. Don't attempt to repair or modify parts that are broken or defective. Please contact the store immediately.
2. This product is for home use only and not intended for commercial establishments.



ASSEMBLY TIME

60 MINUTES



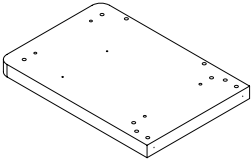
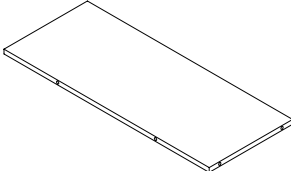
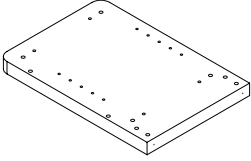
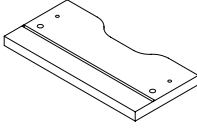
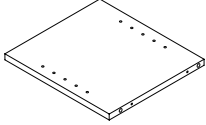
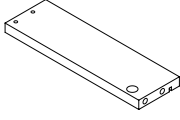
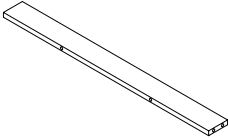
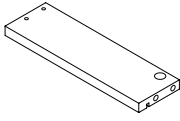
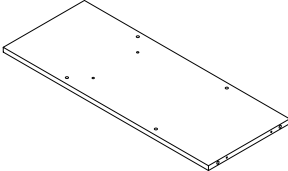
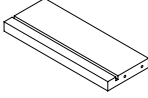
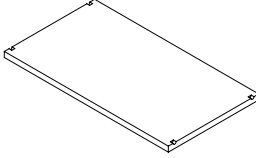
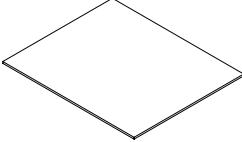
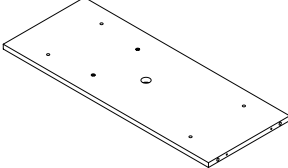
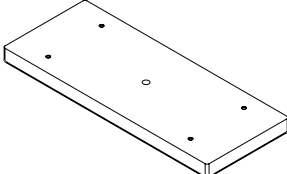

## PARTS IDENTIFICATION

A	LEFT SIDE PANEL		1 PC	H	BACK PANEL		1 PC
B	RIGHT SIDE PANEL		1 PC	I	DRAWER FRONT PANEL		1 PC
C	MIDDLE DIVIDER PANEL		1 PC	J	DRAWER BACK PANEL		1 PC
D	CROSS BRACE		2 PCS	K	DRAWER LEFT SIDE PANEL		1 PC
E	BOTTOM PANEL		1 PC	L	DRAWER RIGHT SIDE PANEL		1 PC
F	ADJUSTABLE SHELF		1 PC	M	DRAWER BOTTOM PANEL		1 PC
G	TOP PANEL		1 PC	N	SEAT CUSHION		1 PC

### NOTE:

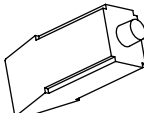
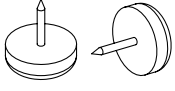
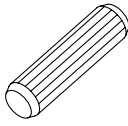
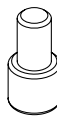
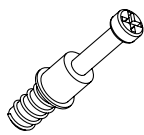
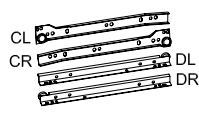
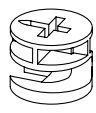
Phillips head screw driver is required in the assembly process; however, manufacturer does not provide this item.

# HARDWARE IDENTIFICATION

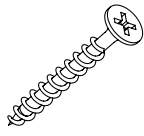
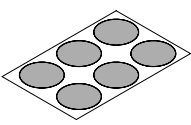
Z							
NO	DESCRIPTION	FIGURE	Q'TY	NO	DESCRIPTION	FIGURE	Q'TY
1	GLUE 40g		1 PC	7	PLASTIC FEET Ø15mm		4 PCS
2	WOODEN DOWEL Ø8x30mm		34 PCS	8	PIN FOR ADJUSTABLE SHELF Ø4.9 x 15mm SR		4 PCS
3	CAM BOLT Ø7x35.5mm SR		2 PCS	9	GLIDES L = 250mm		1 SET
4	CAM LOCK Ø15x12mm SR		2 PCS	10	SCREW FOR HINGE Ø3x12mm BLK		10 PCS
5	LONG SCREW Ø4.5x42mm SR		12 PCS	11	BOLT M6x25mm BLK		4 PCS
6	SCREW Ø4.3x35mm SR		4 PCS	12	STICKER Ø20mm		1 PC

Z9 not included in blister packaging.

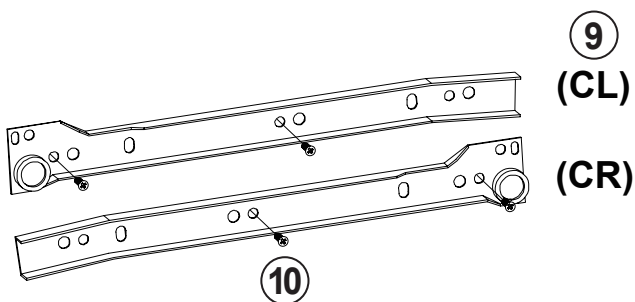

**NOTE:**

Phillips head screw driver is required in the assembly process; however, manufacturer does not provide this item.

# STEP 1

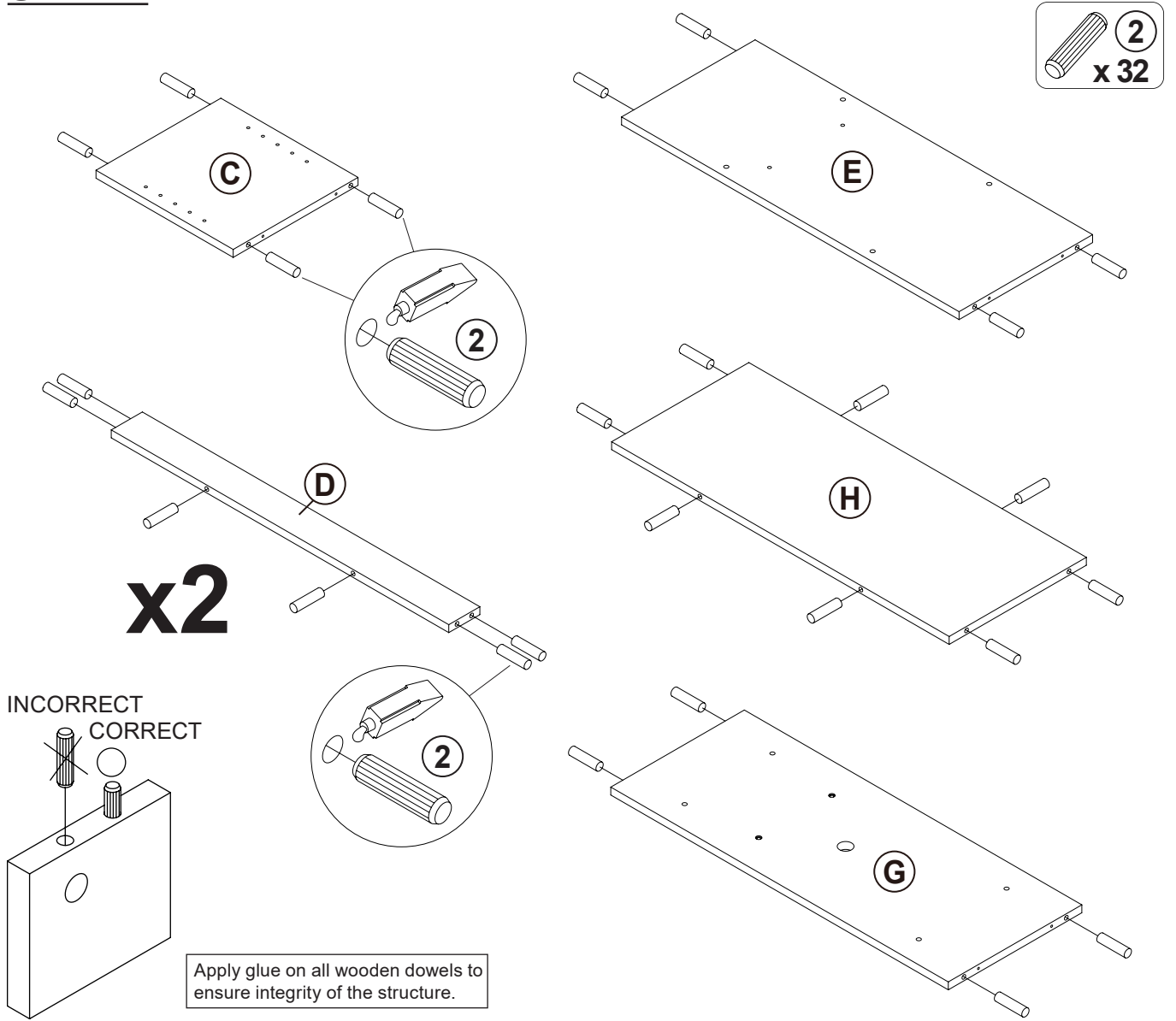

# STEP 2

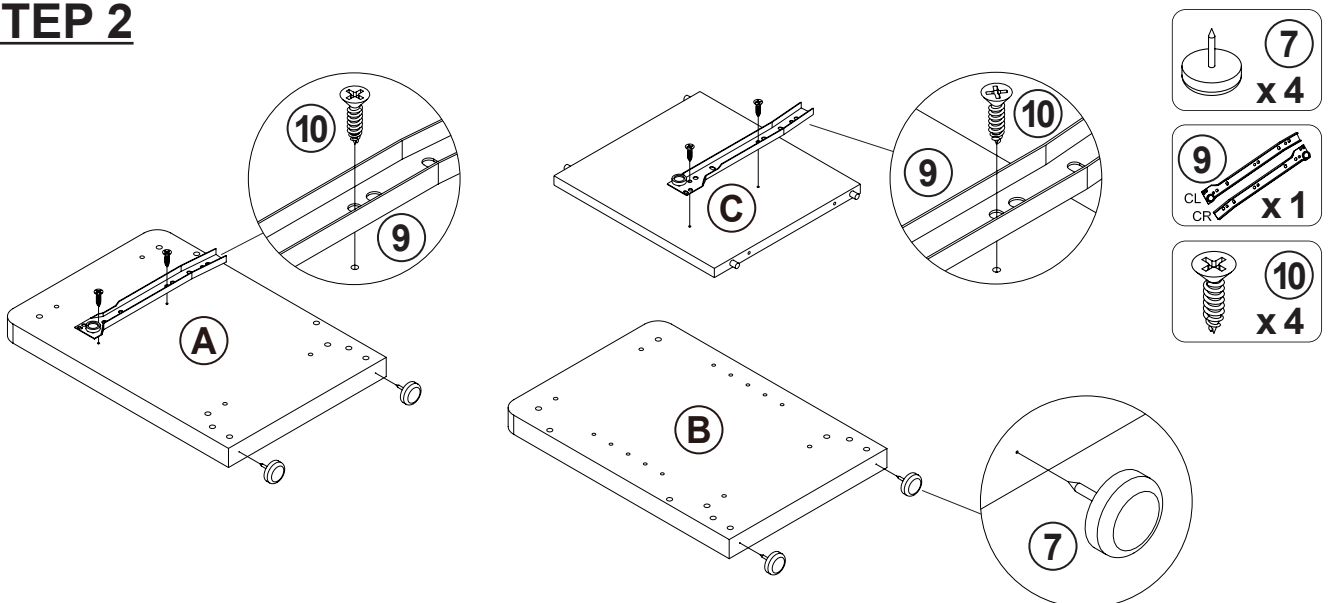

## STEP 3

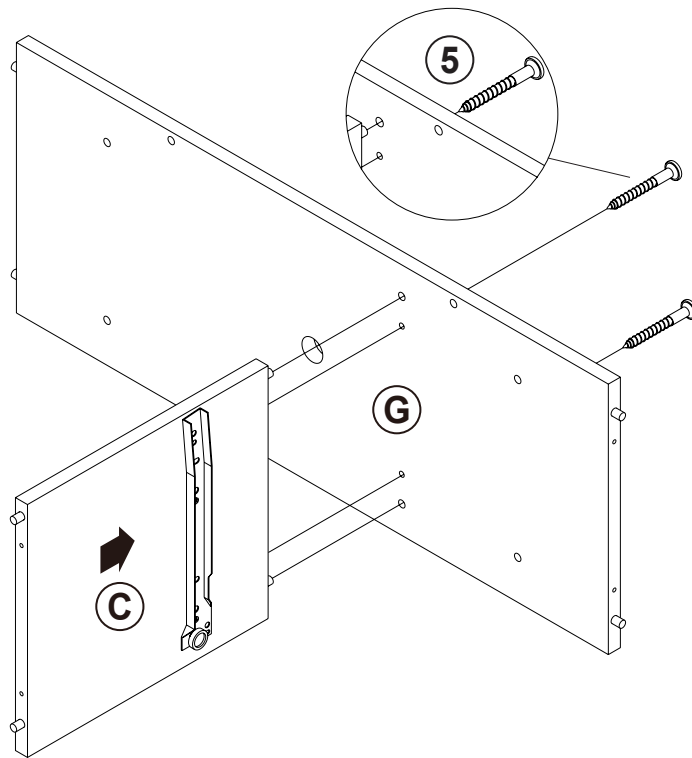

## STEP 4

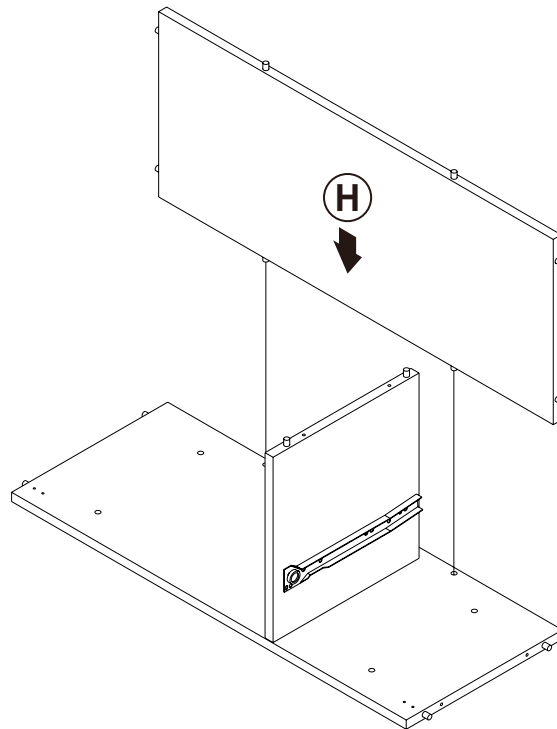

## STEP 5

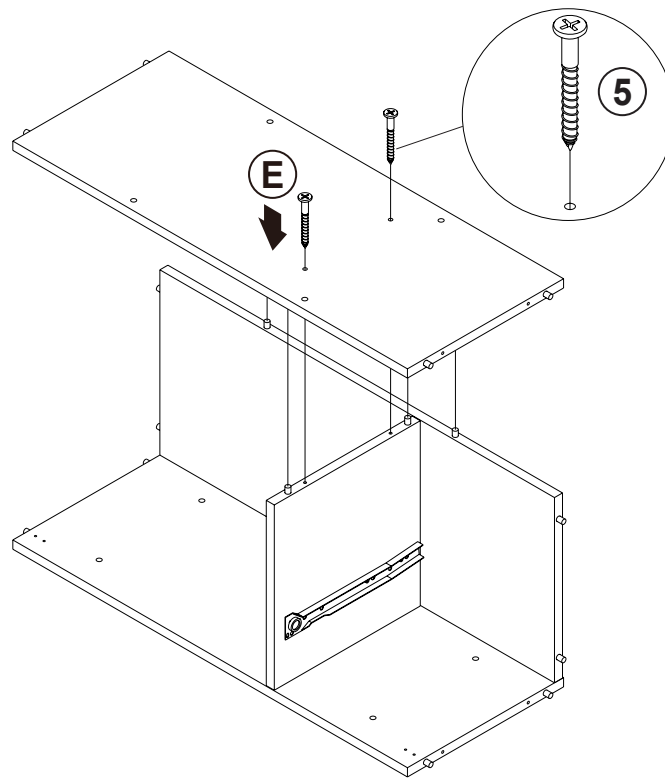
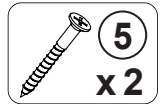

## STEP 6

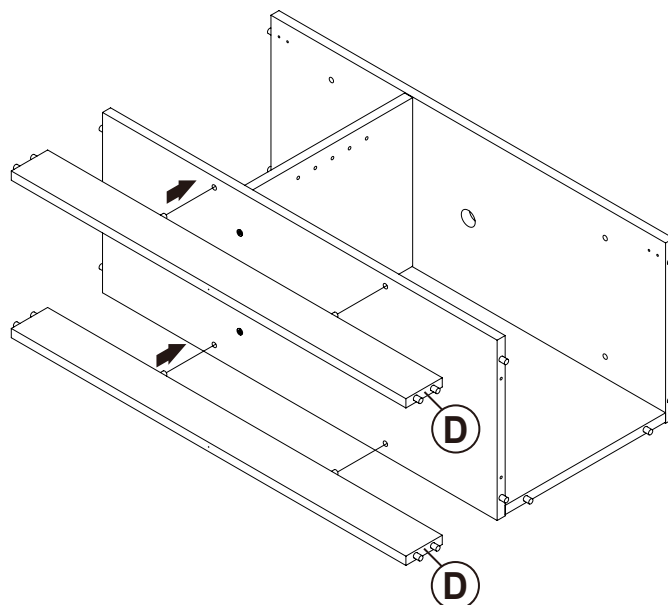

## STEP 7

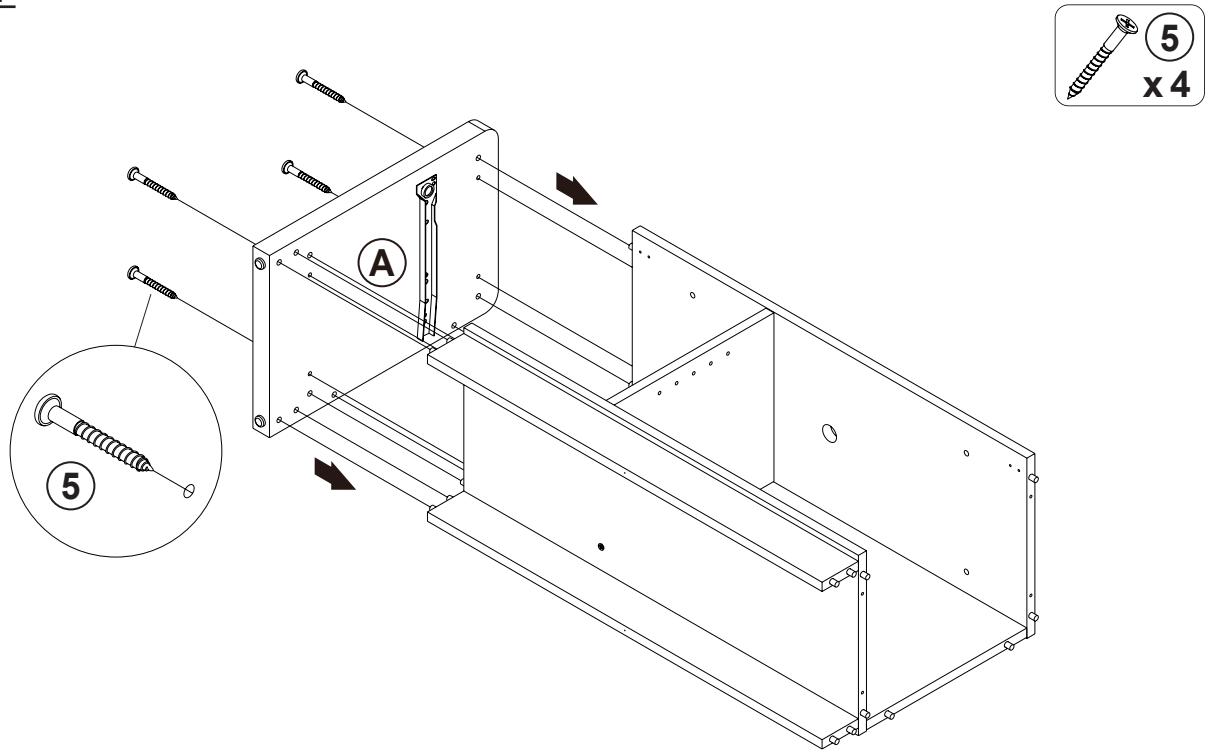

## STEP 8

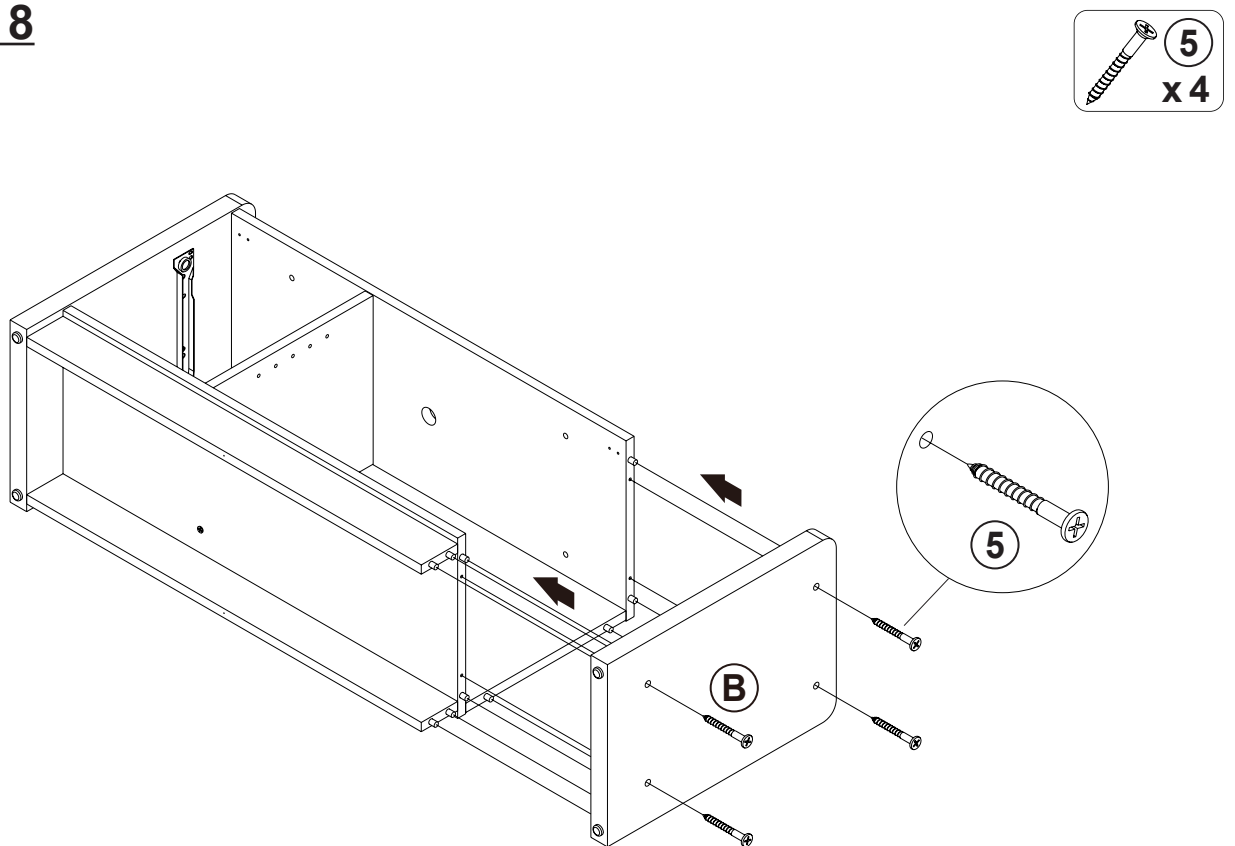

## STEP 9

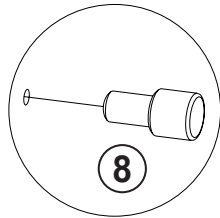
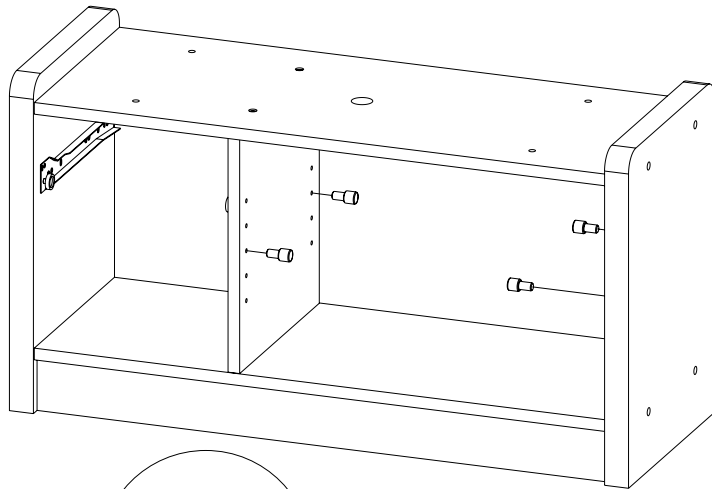
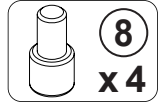

---

## STEP 10

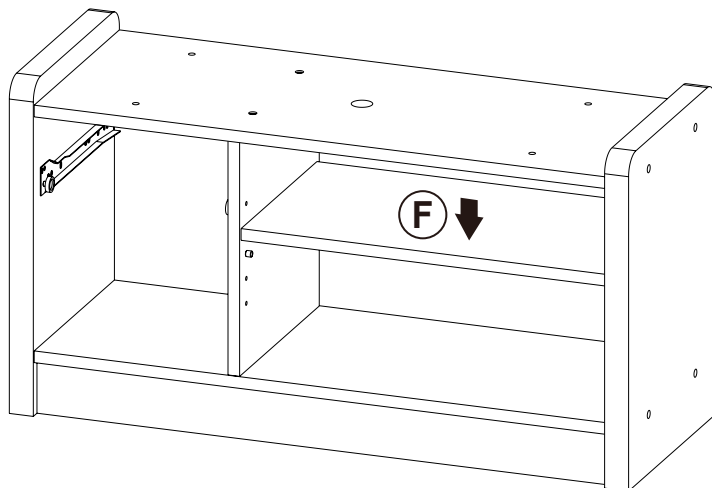

## STEP 11

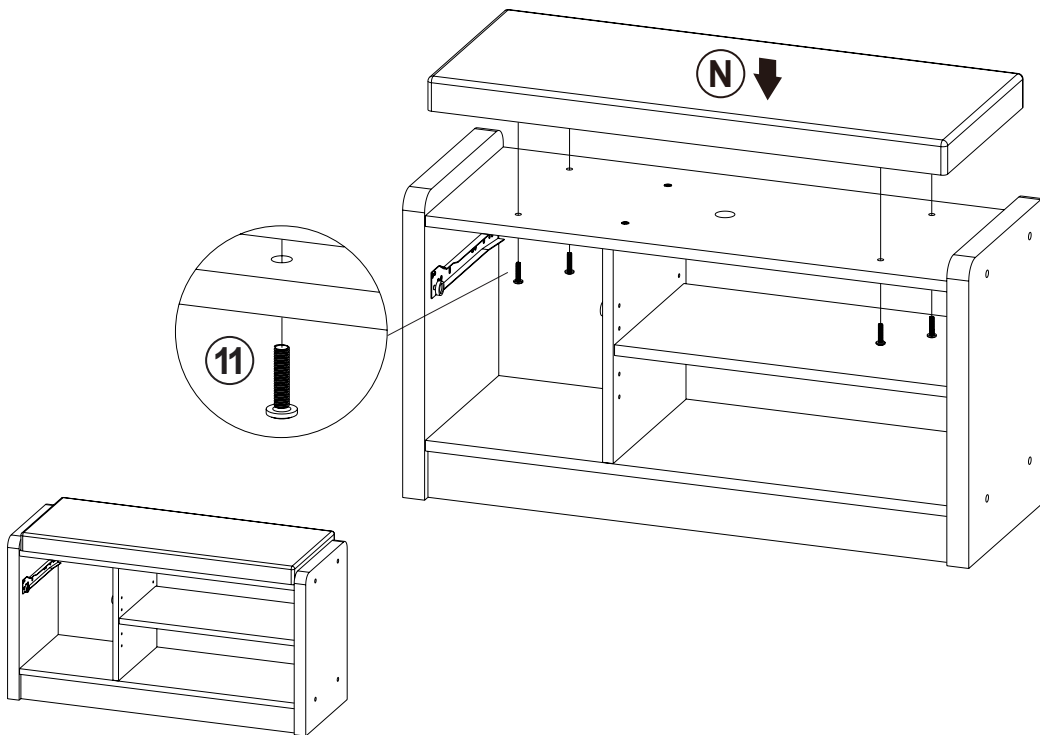
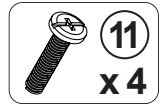

## STEP 12

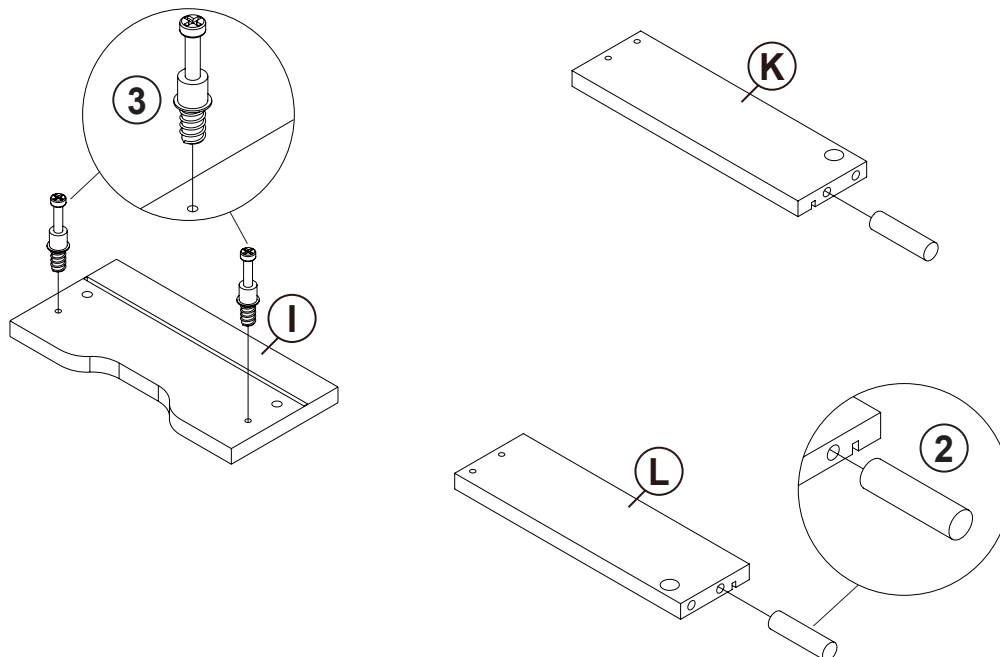
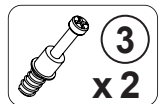
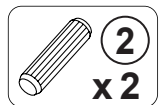

## STEP 13

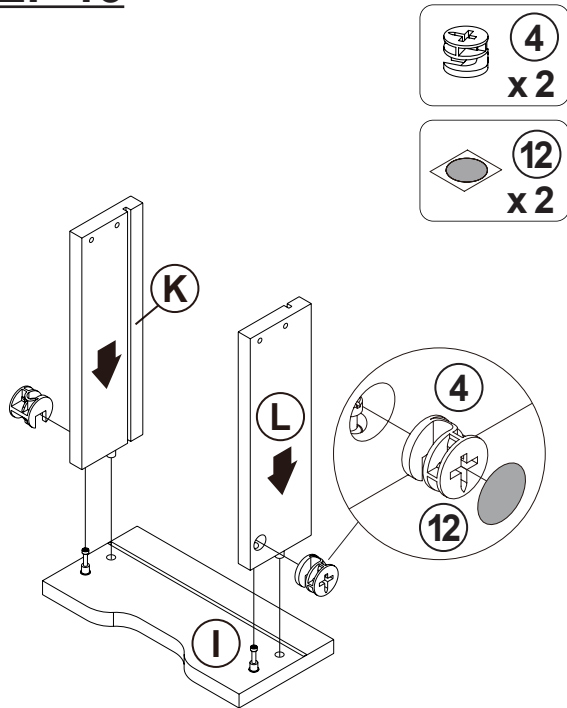

Apply glue on all wooden dowels to ensure integrity of the structure.

## STEP 14

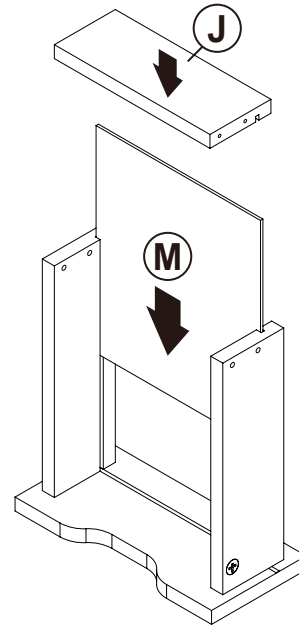

## STEP 15

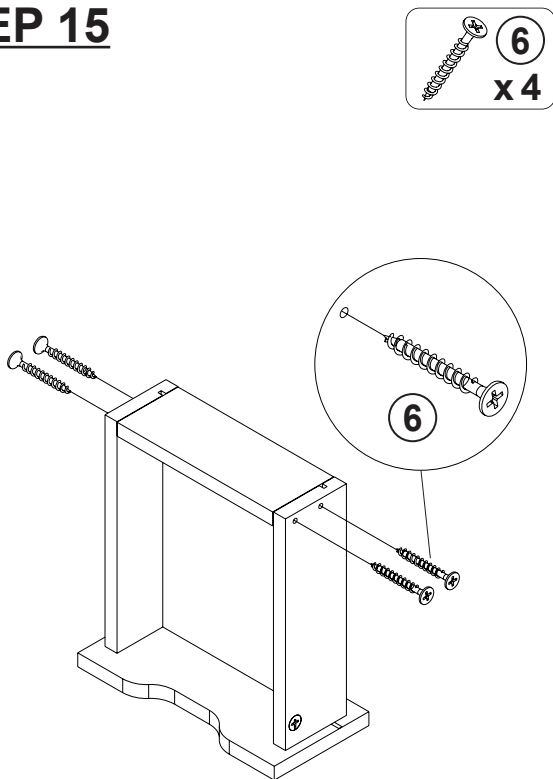

## STEP 16

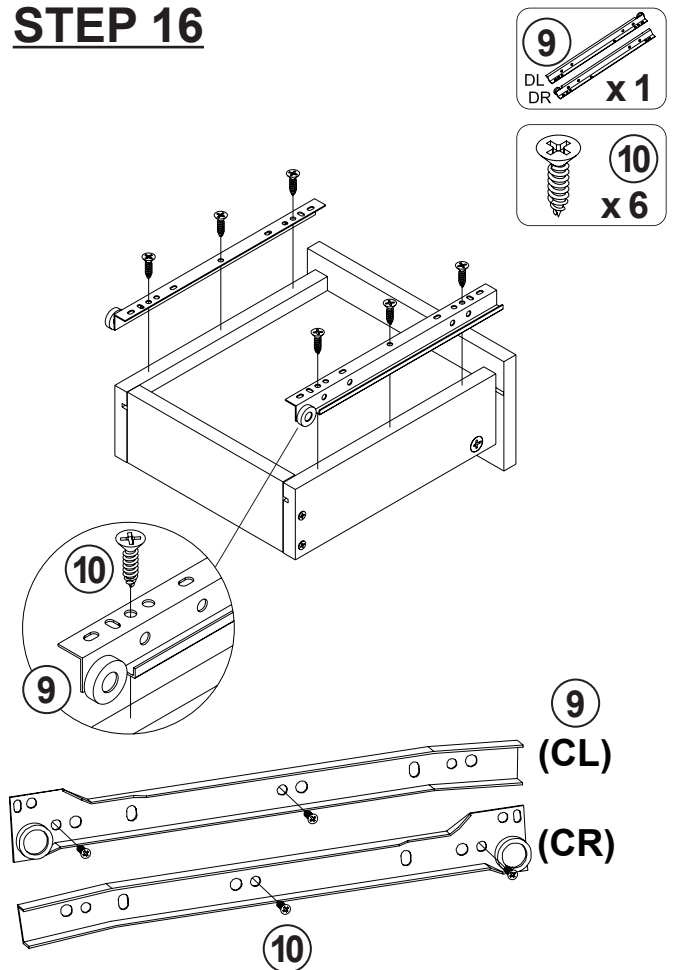

## **STEP 17**

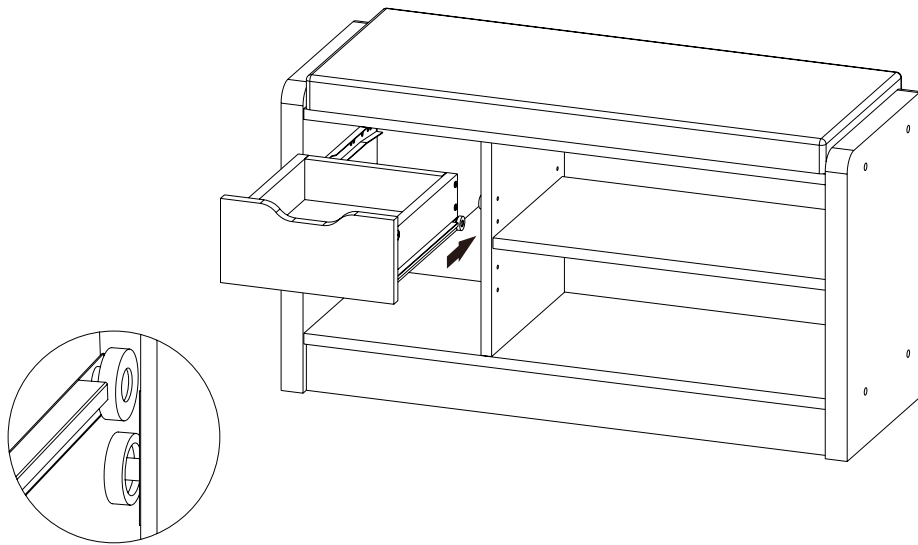

---

## **STEP 18** **COMPLETE**

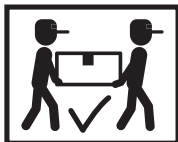
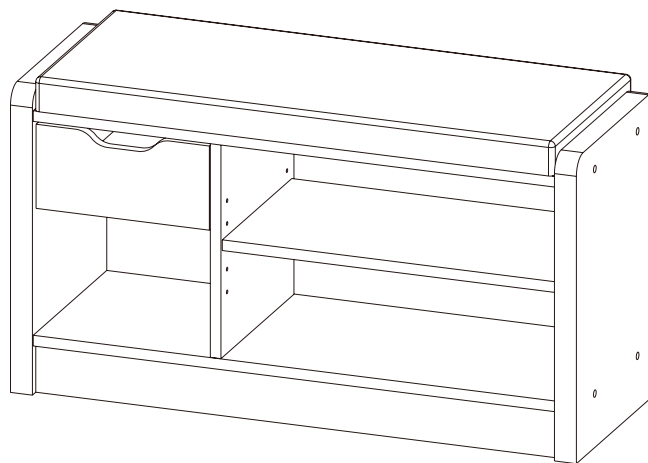

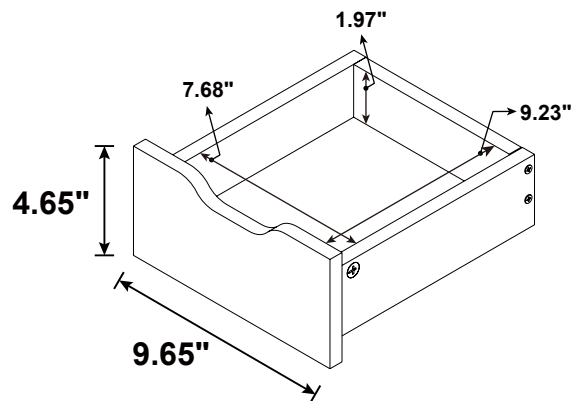
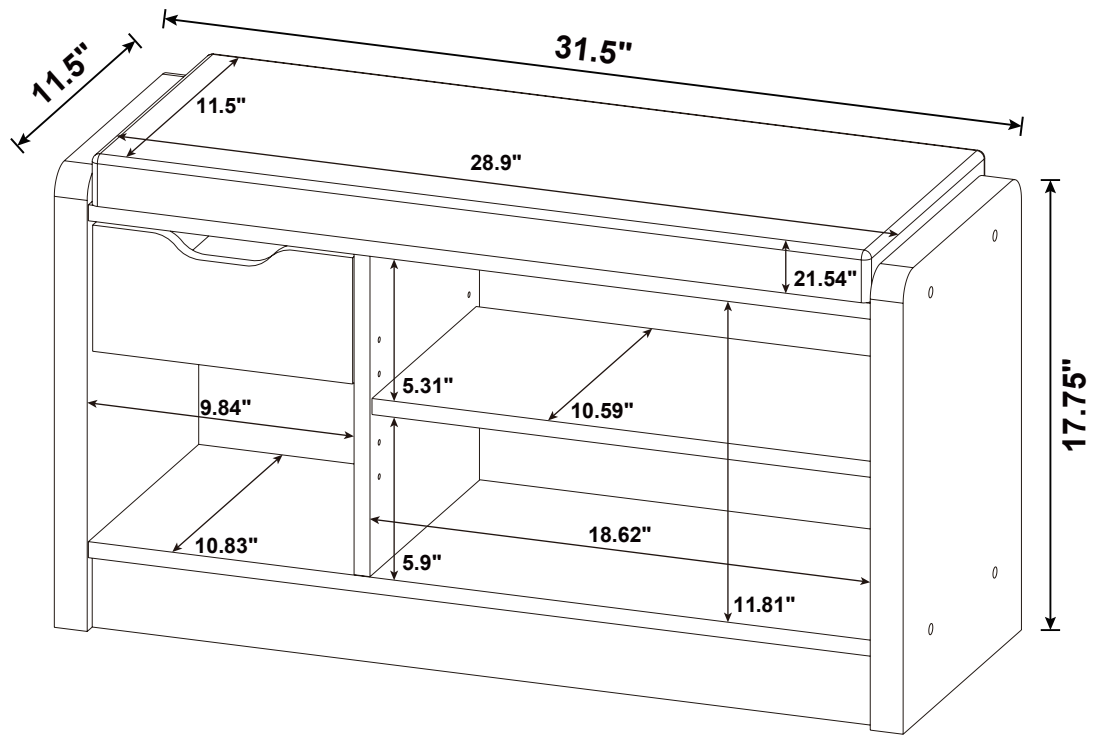

Note : Dimension tolerance  $\pm 5\%$