

ASSEMBLY INSTRUCTION

Item No: N36E-9572-3P

Description: 3-PACK COUNTER TABLE WITH 2 STOOLS

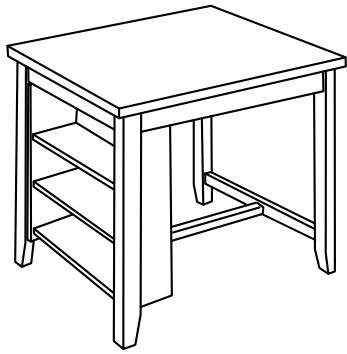

IMPORTANT NOTE :

- Place all wooden parts on a clean and smooth surface such as a rug or carpet to avoid the parts from being scratched.
- Check to be sure that you have all parts and hardware.
- Remove all wrapping materials, including staples & packing straps before you start to assemble.
- Do not tighten all screws/bolts until all completely assembled.
- Keep all hardware parts out of reach of children.
- Tighten screws periodically! With the use of this product bolts and screws may become loose over time!
- Do not attempt to modify parts!

PARTS LIST		
NO.	COMPONENT	QTY.
1	TABLE TOP	1 PCS
2	TABLE STORAGE PANEL	1 PCS
3	TABLE SHELF	3 PCS
4	SHORT STRETCHER	1 PCS
5	LONG STRETCHER	1 PCS
6	TABLE LEG L	1 PCS
7	TABLE LEG R	1 PCS
8	TABLE LEG 1	1 PCS
9	TABLE LEG 2	1 PCS

HARDWARE LIST		
NO.	DESCRIPTION	QTY.
A	M4 x 110MM ALLEN KEY	1 PCS
B	M5 x 85MM ALLEN KEY	1 PCS
C	SHELF SUPPORT PEGS	12 PCS
D	M8 x 60MM JCBC BOLT	8 PCS
E	M8 x 14MM SPRING WASHER	8 PCS
F	M8 x 22MM FLAT WASHER	8 PCS
G	M6 x 40MM JCBC BOLT	8 PCS
H	M6 x 13MM SPRING WASHER	8 PCS
I	M6 x 19MM FLAT WASHER	6 PCS
J	D SHAPE SPACER	2 PCS
K	M8 x 25MM WOOD DOWEL	4 PCS
L	M4 x 45MM PAN HEAD SCREW	2 PCS

STEP 1

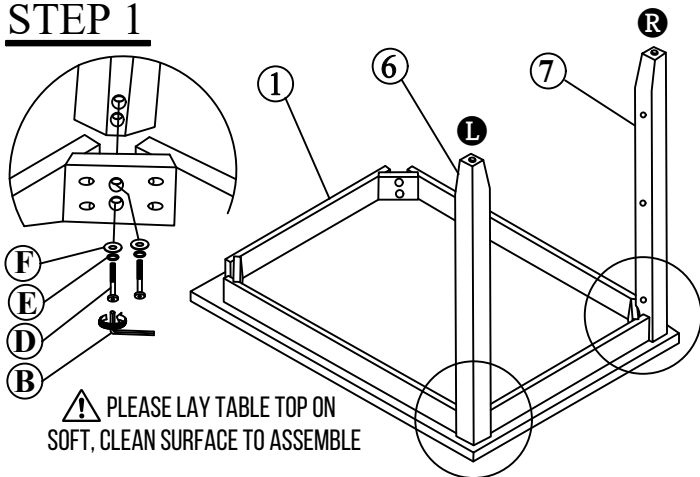

STEP 2

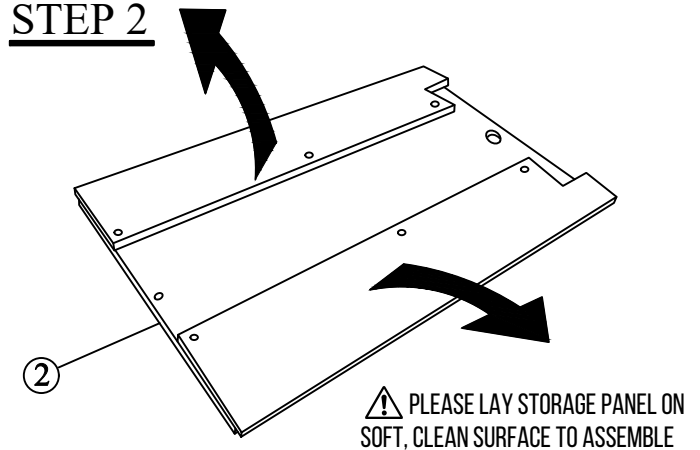

STEP 3

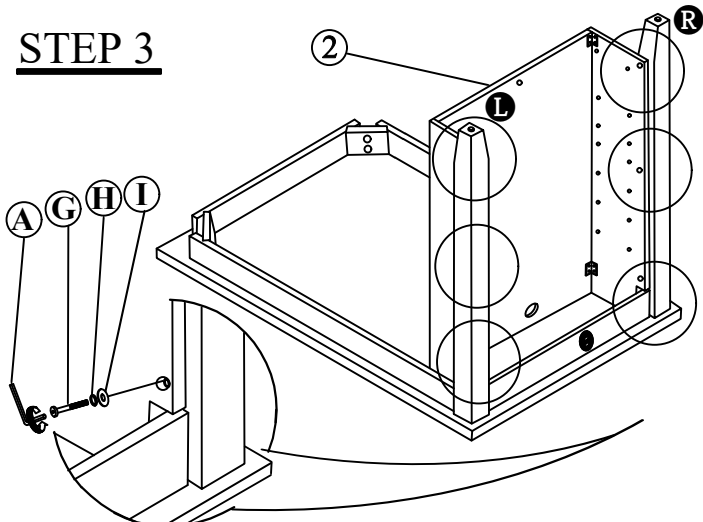

STEP 4

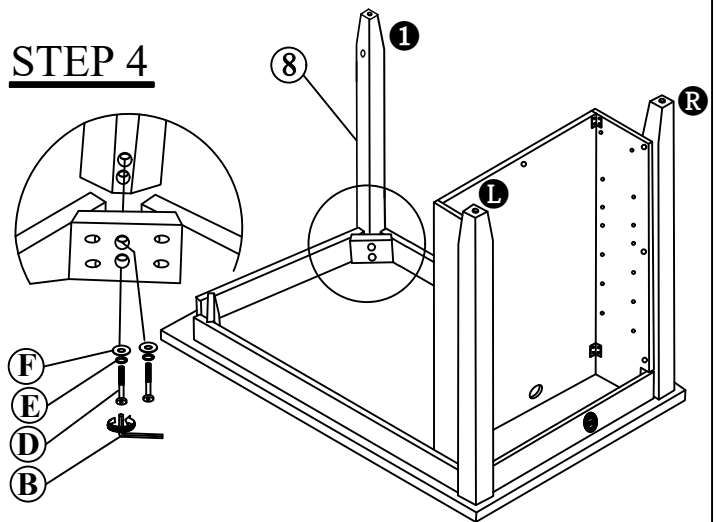

STEP 5

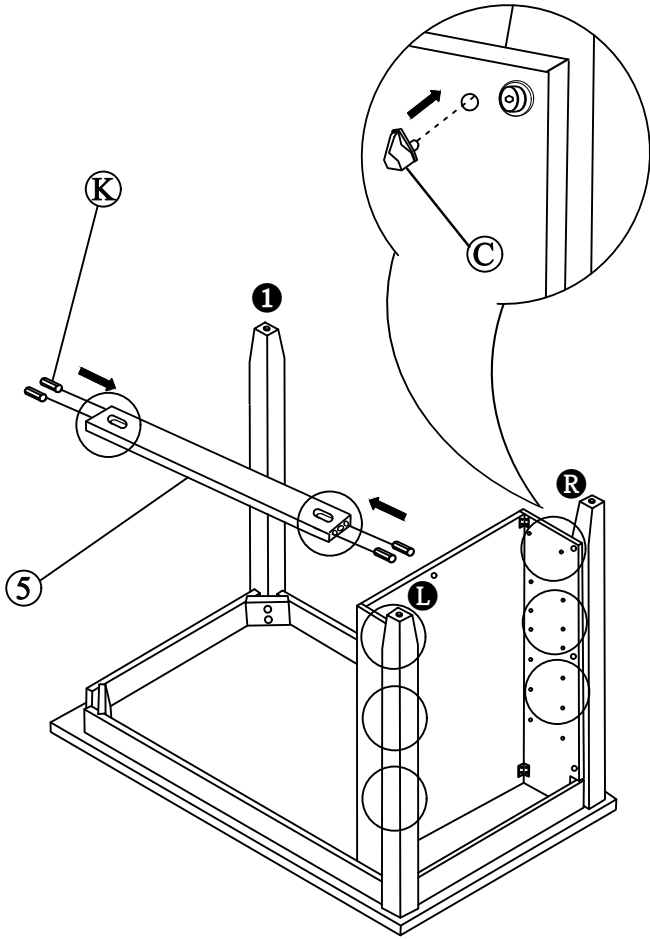

STEP 6

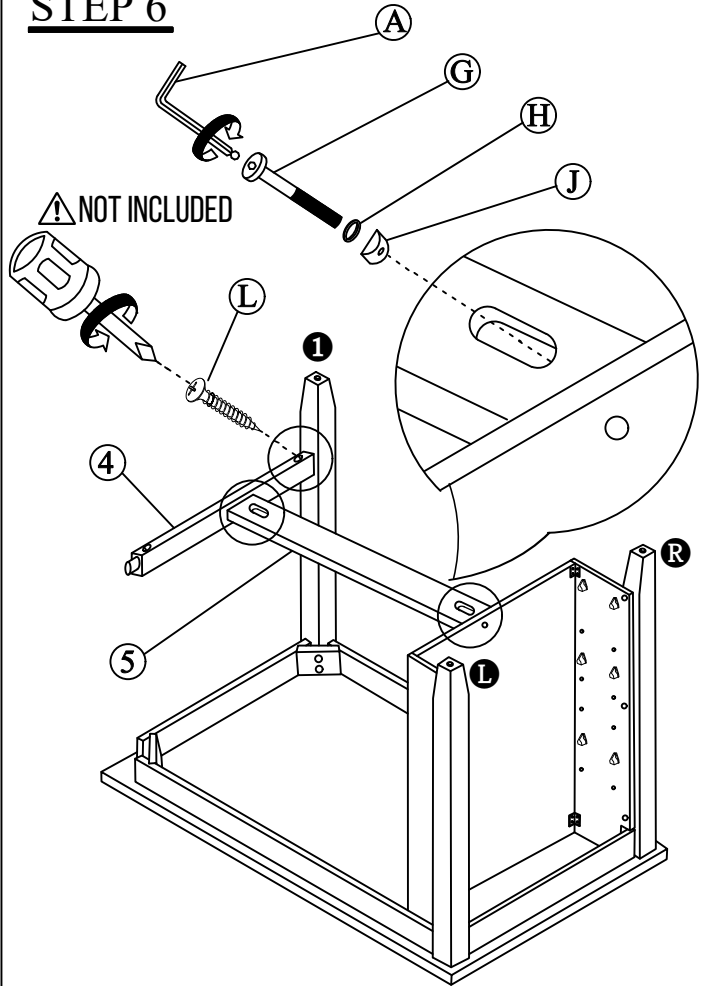

STEP 7

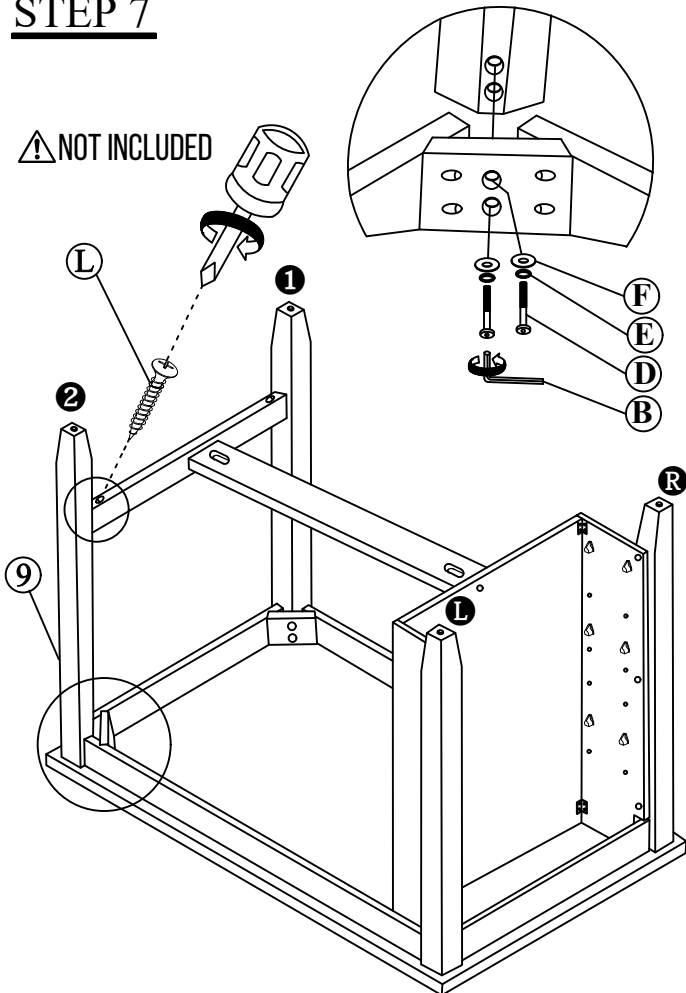

STEP 8

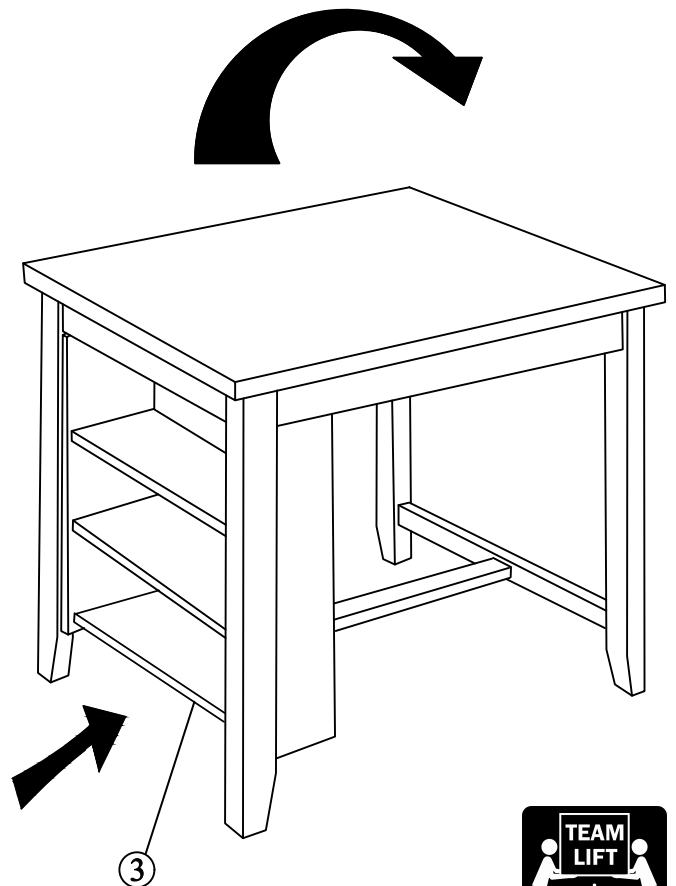

ASSEMBLY INSTRUCTION

Item No: N36E-9572-3P

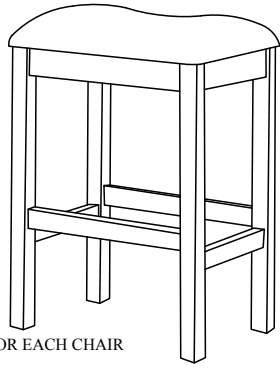

Description: 3-PACK COUNTER TABLE WITH 2 STOOLS





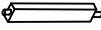
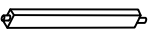

▲ PARTS FOR EACH CHAIR

IMPORTANT NOTE :

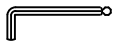
- Place all wooden parts on a clean and smooth surface such as a rug or carpet to avoid the parts from being scratched.
- Check to be sure that you have all parts and hardware.
- Remove all wrapping materials, including staples & packing straps before you start to assemble.
- Do not tighten all screws/bolts until all completely assembled.
- Keep all hardware parts out of reach of children.

PARTS LIST		
NO.	COMPONENT	QTY.
1	SEAT CUSHION 	1 PCS
2	SHORT SIDE STRETCHER 	2 PCS
3	LONG FRONT/ REAR STRETCHER 	2 PCS
4	LEG ① 	2 PCS
5	LEG ② 	2 PCS

HARDWARE LIST		
NO.	DESCRIPTION	QTY.
A	M4 x 110MM ALLEN KEY 	1 PCS
B	M6 x 45MM JCBC BOLT 	8 PCS
C	M6 x 13MM SPRING WASHER 	8 PCS
D	M6 x 19MM FLAT WASHER 	8 PCS
E	M4 x 45MM PAN HEAD SCREW 	8 PCS

STEP 1

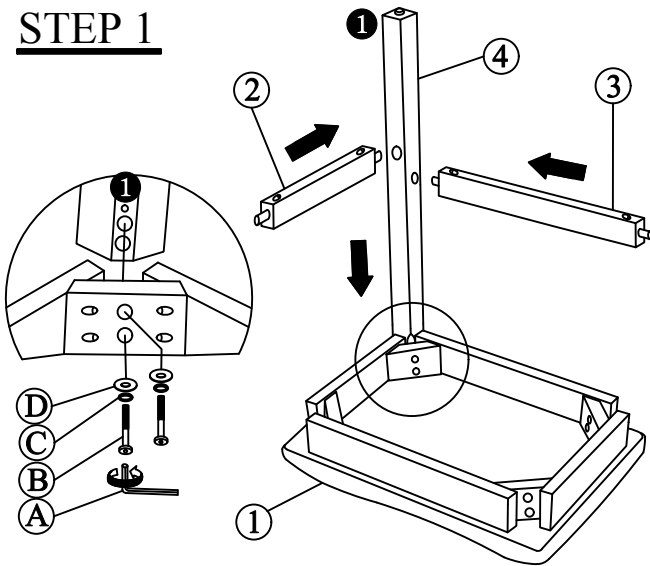

STEP 2

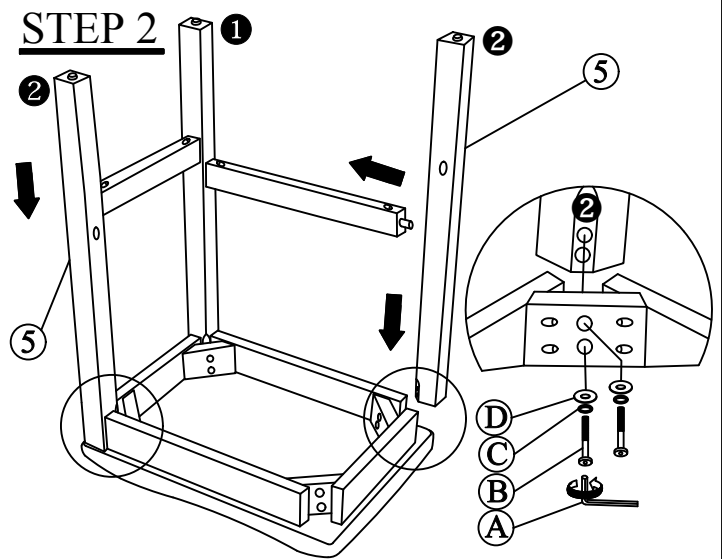

STEP 3

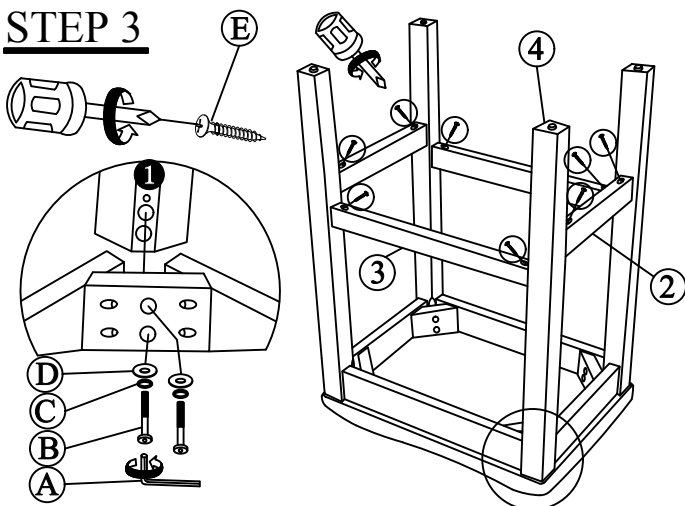

STEP 4

