

Kitchen Island

Assembly instruction

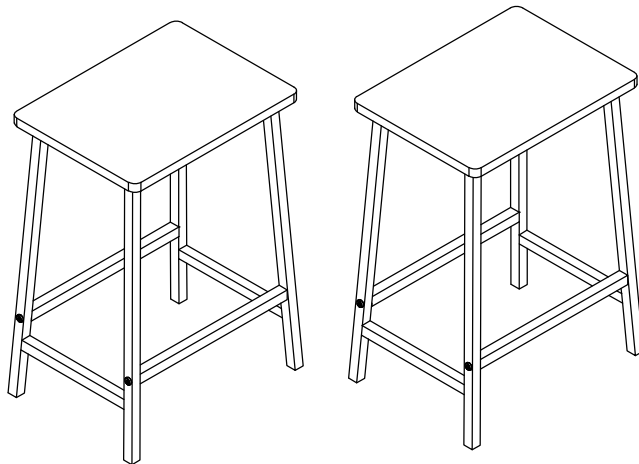
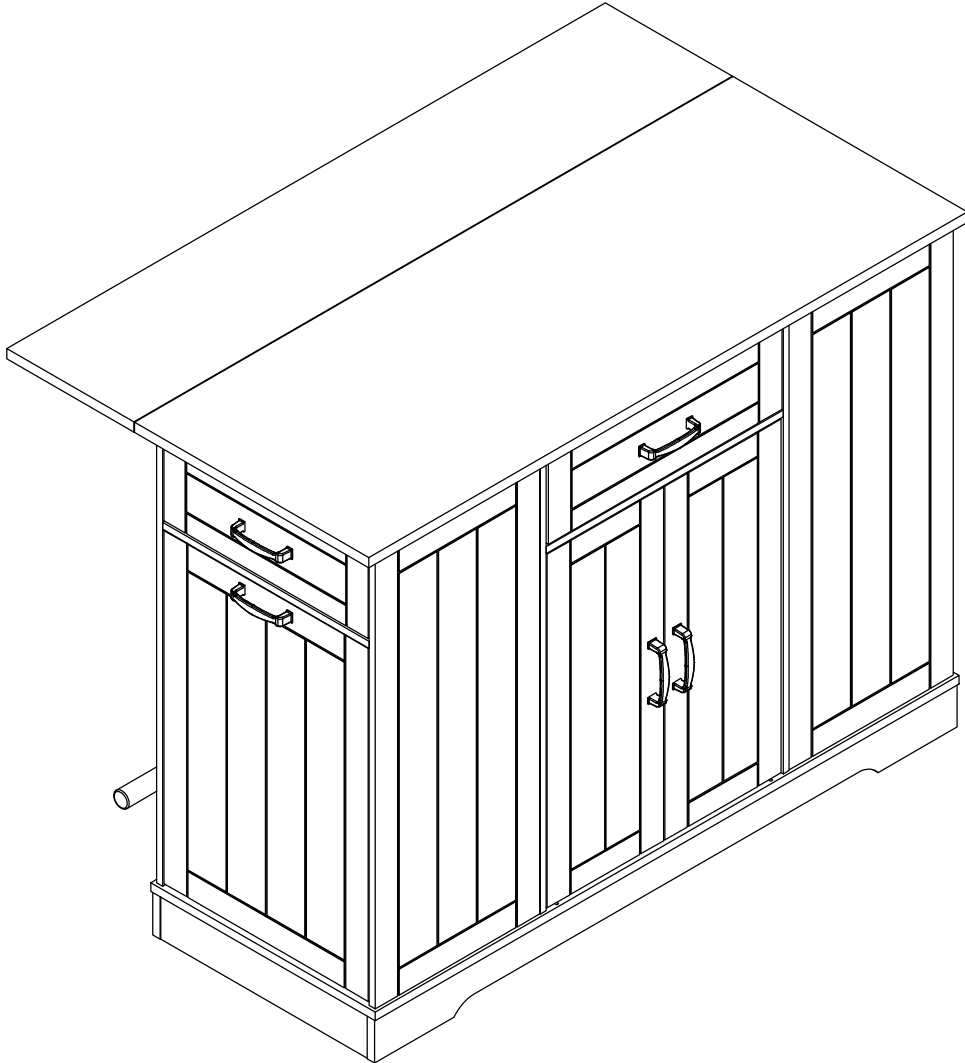

INTRODUCTION

Thank you for purchasing our products. Please read the instructions carefully before installation and keep it in a safe place for future reference. If you need any assistance or support, please feel free to contact our customer support team.

PRECAUTIONS

1. There are many components and accessories in the package. Each component and accessory is labeled with a letter or a number, check carefully before using any of them. Keep them away from children to prevent accidents.
2. Please install the product on a clean and soft underlay (such as carpet or cardboard) to avoid scratching or damaging the surface of the product.
3. The main components of the product are relatively heavy. Please pay attention to safety during installation.
4. The product is not stable during installation. Please do not move it randomly before it is completely installed.
5. This product requires two people to install.
6. If you have any questions during installation, please contact our customer service in time.

***PLEASE BE SURE TO FOLLOW THE INSTALLATION STEPS IN THE MANUAL TO AVOID UNNECESSARY LOSSES CAUSED BY IMPROPER INSTALLATION.**

***IF YOU NEED FURTHER ASSISTANCE, PLEASE CONTACT OUR CUSTOMER SERVICE ONLINE.**

Parts List

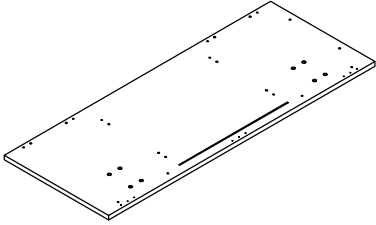

①
1X

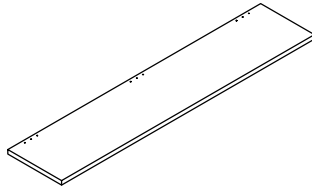

②
1X

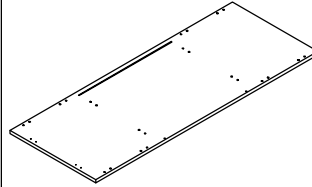

③
1X

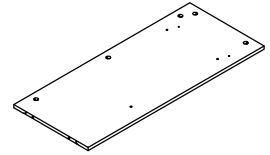

④
1X

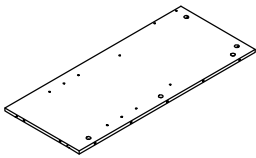

⑤
1X

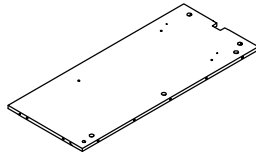

⑥
1X

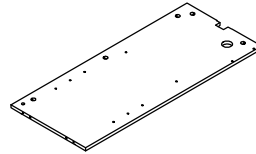

⑦
1X

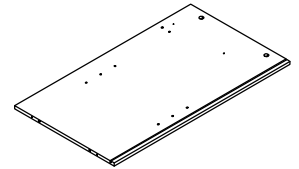

⑧
1X

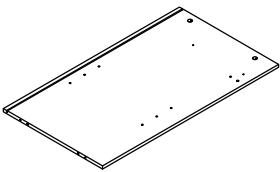

⑨
1X

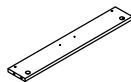

⑩
1X

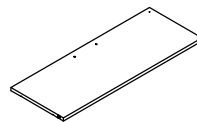

⑪
1X

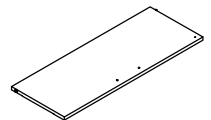

⑫
1X

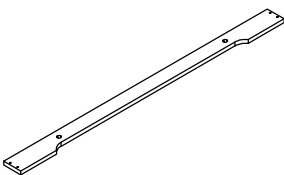

⑬
1X

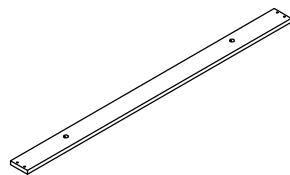

⑭
1X

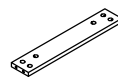

⑮
2X

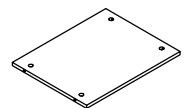

⑯
2X

Parts List

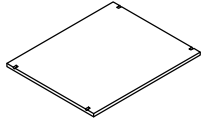

①⑦
1X

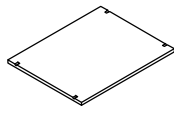

①⑧
1X

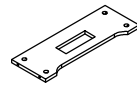

①⑨
1X

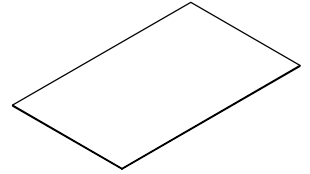

②⑦
1X

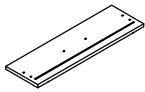

②①
1X

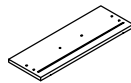

②②
1X

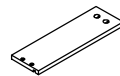

②③
2X

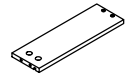

②④
2X

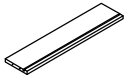

②⑤
1X

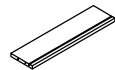

②⑥
1X

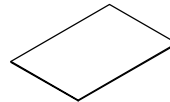

②⑦
1X

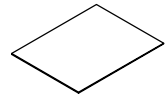

②⑧
1X

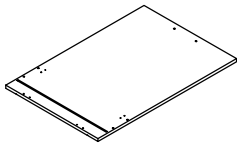

②⑨
1X

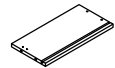

③⑦
1X

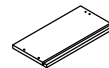

③①
1X

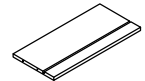

③②
1X

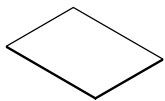

③③
1X

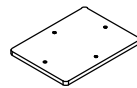

③④
2X

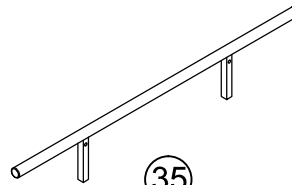

③⑤
1X



③⑥
2X

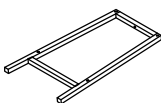

③⑦
4X













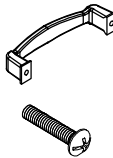



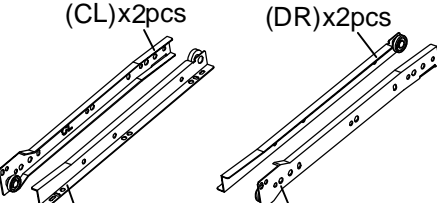

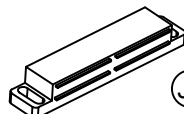

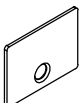

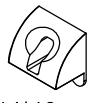
③⑧
4X

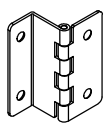

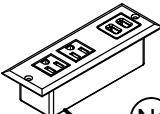
③⑨
4X

Hardware List

 4mm (A) 1X	 Ø5*40mm (B) 12X	 Ø6*30mm (C) 40X	 (D1) X5Pcs (D2) X10Pcs M4*16 mm (D)	
 Ø3.5*30mm (E) 12X	 Ø6*35mm (F1) 66X	 Ø15*9mm (F2) 66X	 (CL)x2pcs (DL)x2pcs (DR)x2pcs (CR)x2pcs (G)	
 Ø3*12mm (H) 20X	 (J1) x1Pcs 70*17*13mm  (J2) x2Pcs Ø3*15mm (J)	 (K1) x2Pcs 30*22*1mm  (K2) x2Pcs Ø3*12mm (K)	 (L1) x8Pcs 14*10mm  (L2) x8Pcs Ø3*16mm (L)	
 (M1) x2Pcs 41.5*18.5mm  (M2) x 8Pcs Ø3.5*12mm (M)	 (N1) x1Pcs  (N2) x2Pcs Ø3.5*14mm (N)	 Ø3.5*14mm (O) 18X	 M5*18mm (P) 2X	

Hardware List

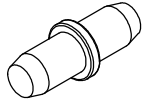

Ø5*Ø7*17mm

Q

8X

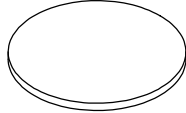

Ø20mm

R

36X

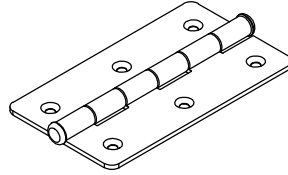

S

3X

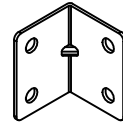

T1 x2Pcs



T2 x8Pcs

Ø3.5*12mm

T

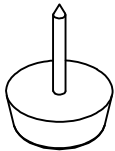

Ø12*4mm

U

8X



M6*10mm

V

8X

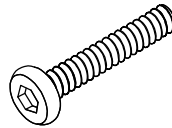

M6*30mm

W

8X

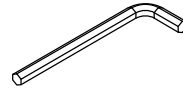

5mm

ZE

1X

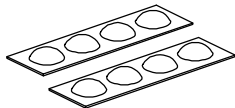

Y

8X

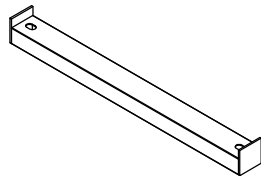

330*31*31mm

ZA

2X

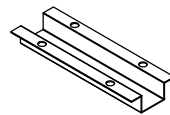

170*64*21.5mm

ZB

2X

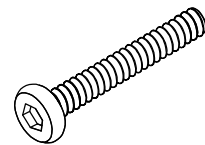

M6*40mm

ZD

16X

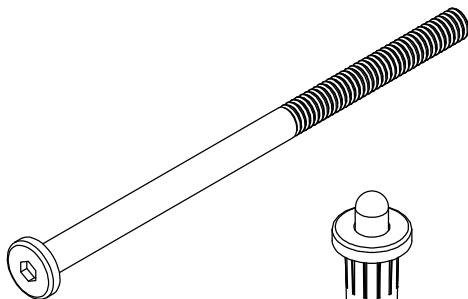

M8*140mm

ZF

2X

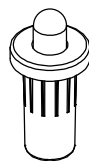

ZC

4Pcs

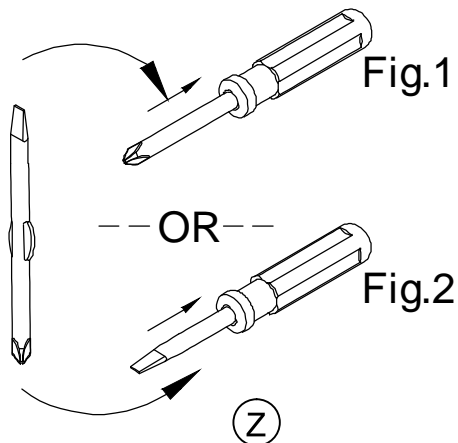
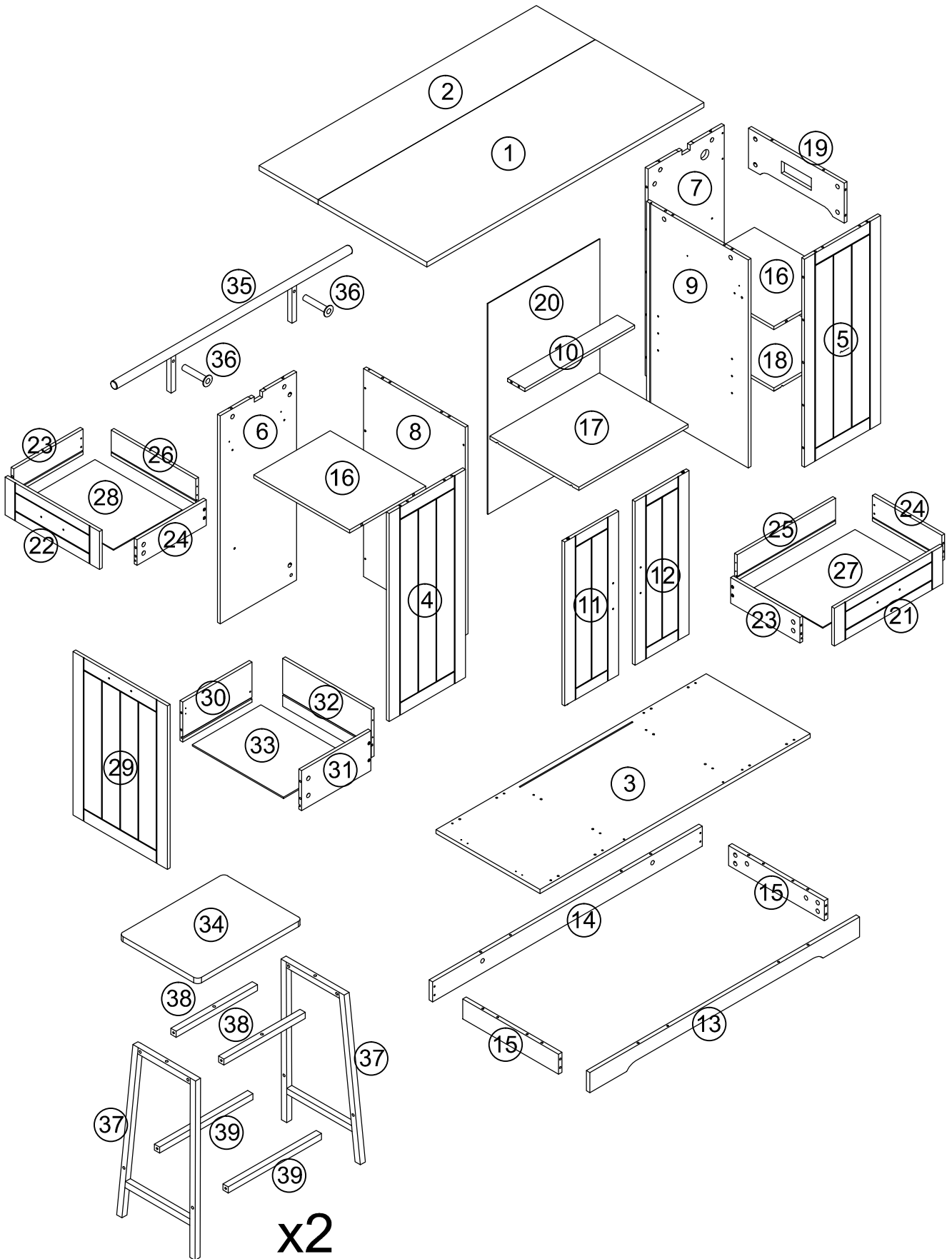

Fig.1

Fig.2

Z



Step 1.

(CL)X1

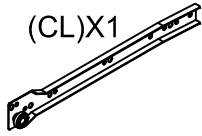

(G)

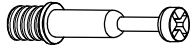

(F1) X2



(H) X2

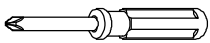

(Z)

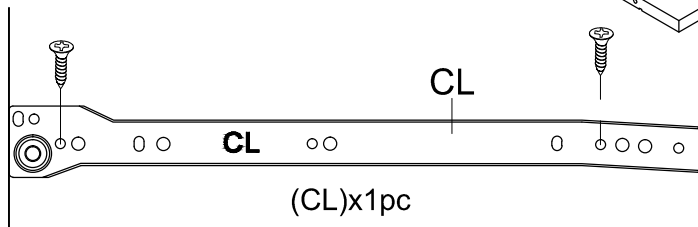
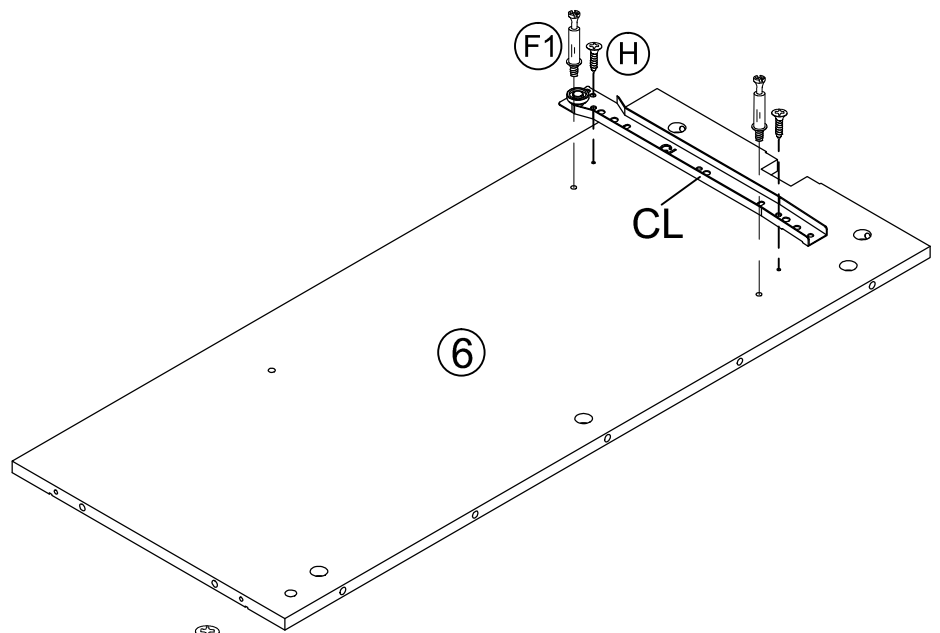

Step 2.

(CR)X1

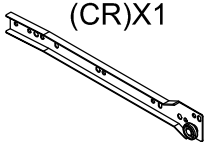

(G)

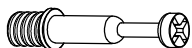

(F1) X2



(H) X2



(Z)

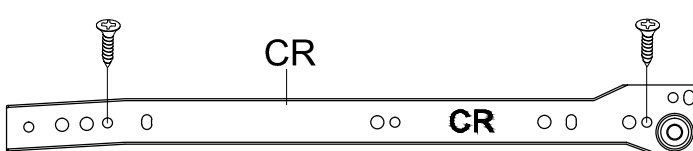
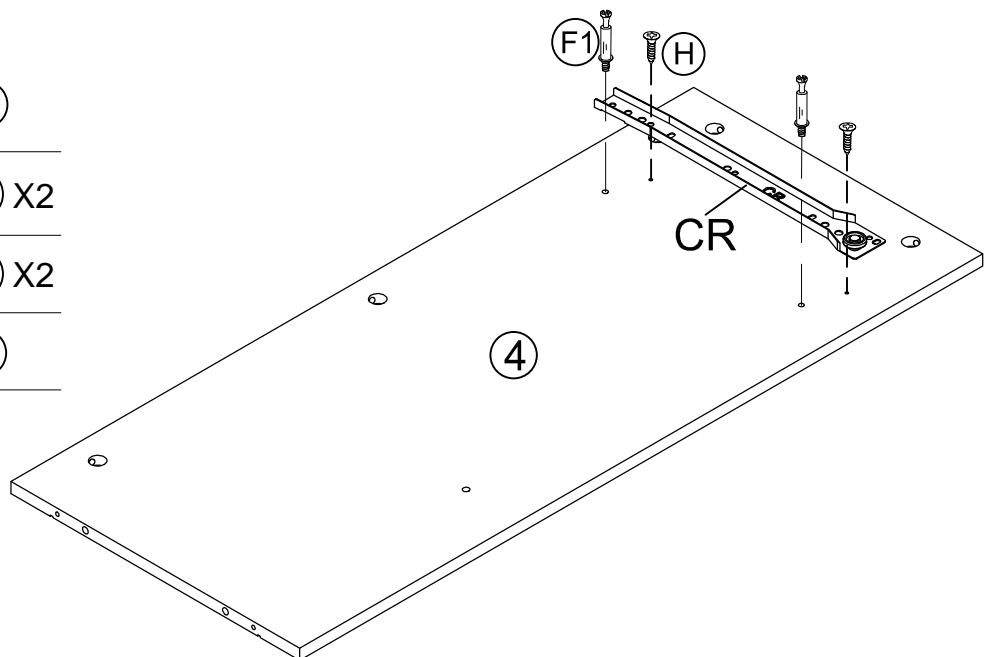

Step 3.

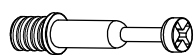

F1 X6

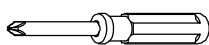

Z

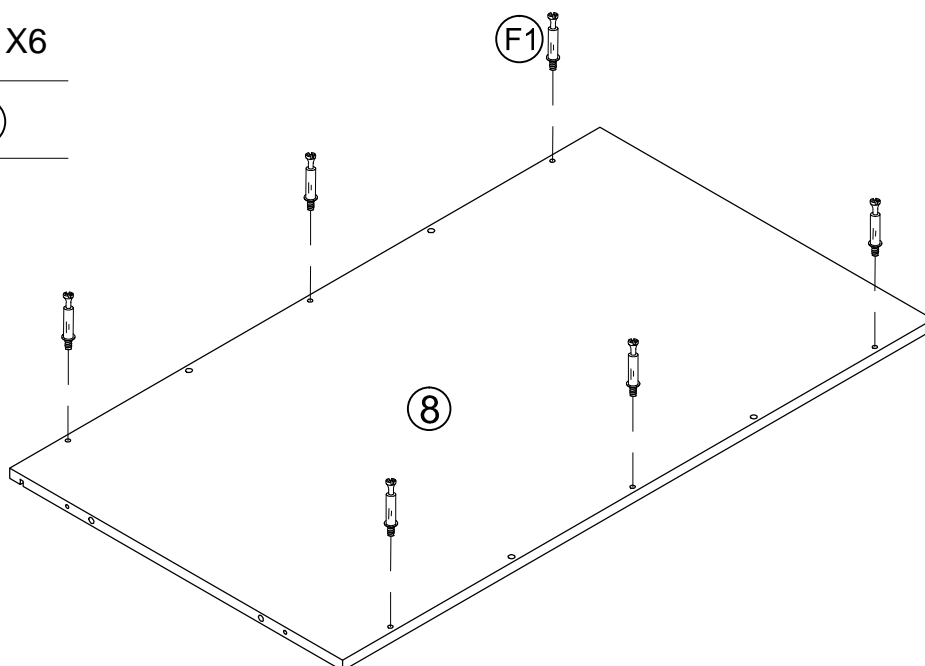

Step 4.

(CL)X1

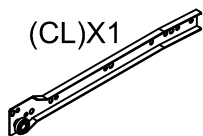

G

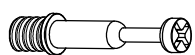

F1 X1



H X2

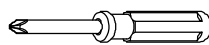

Z

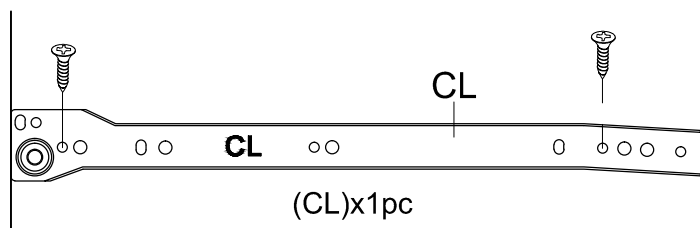
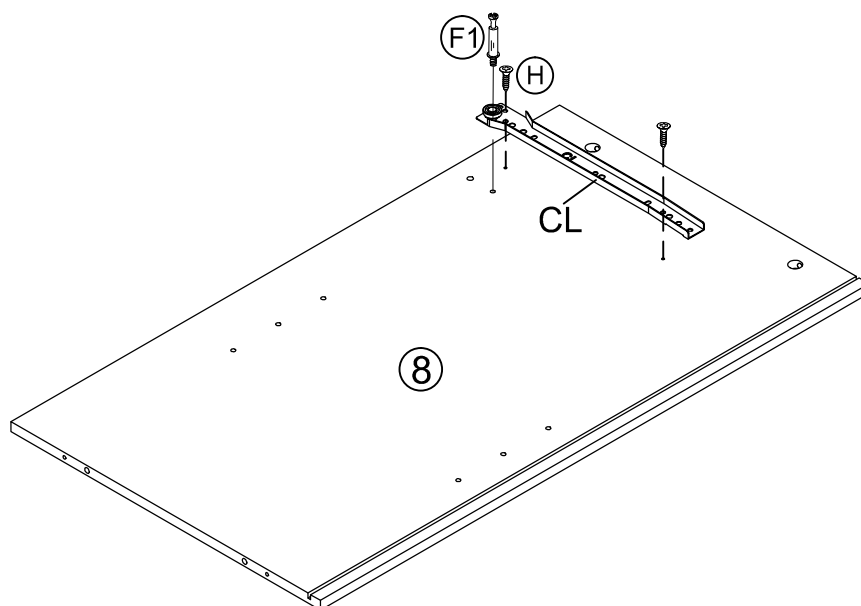

Step 5.

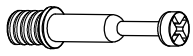

(F1) X6

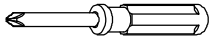

(Z)

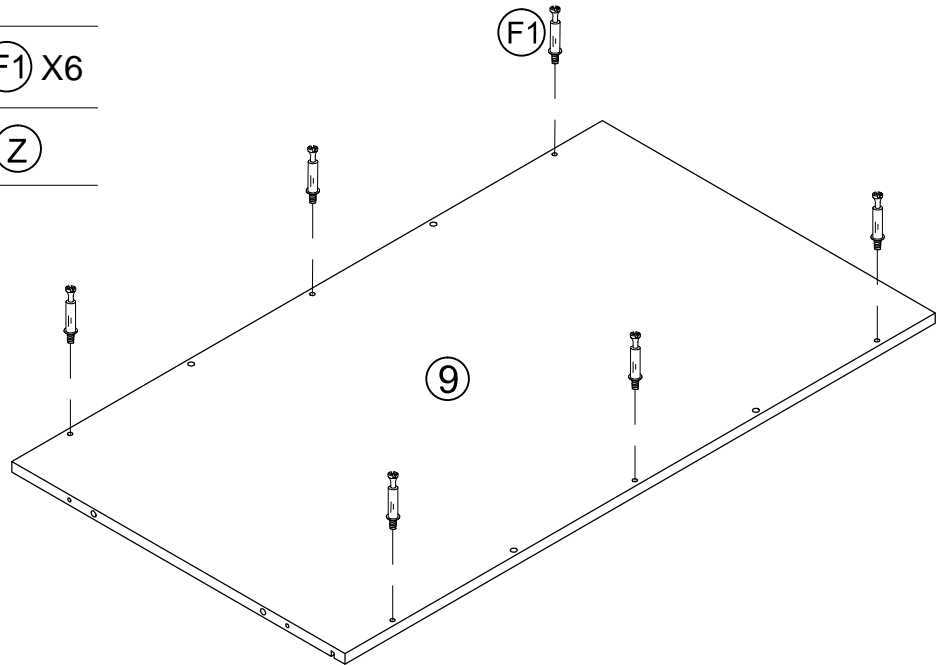

Step 6.

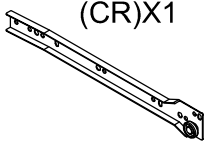

(CR)X1

(G)

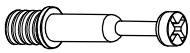

(F1) X1



(H) X2

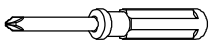

(Z)

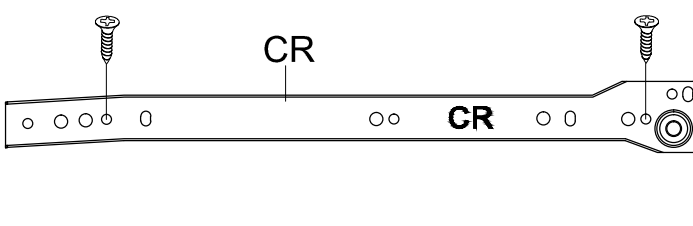
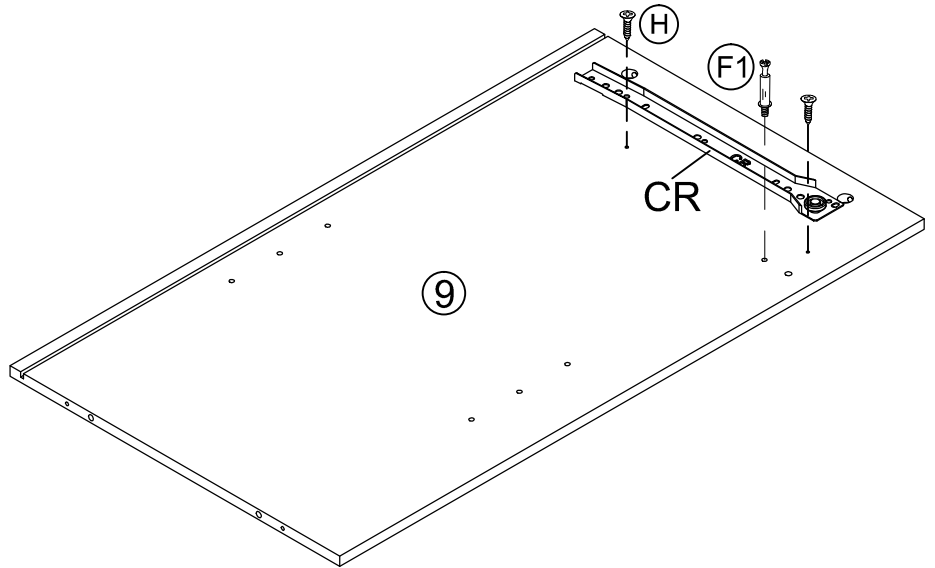

Step 7.

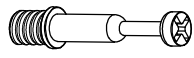

(F1) X4

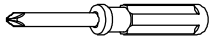

(Z)

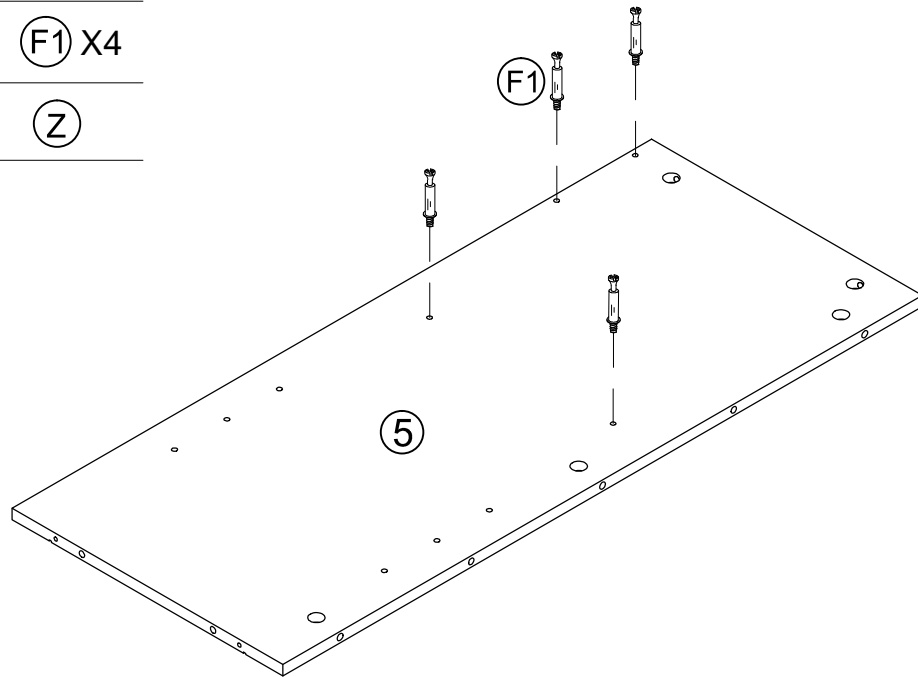

Step 8.

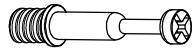

(F1) X4

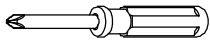

(Z)

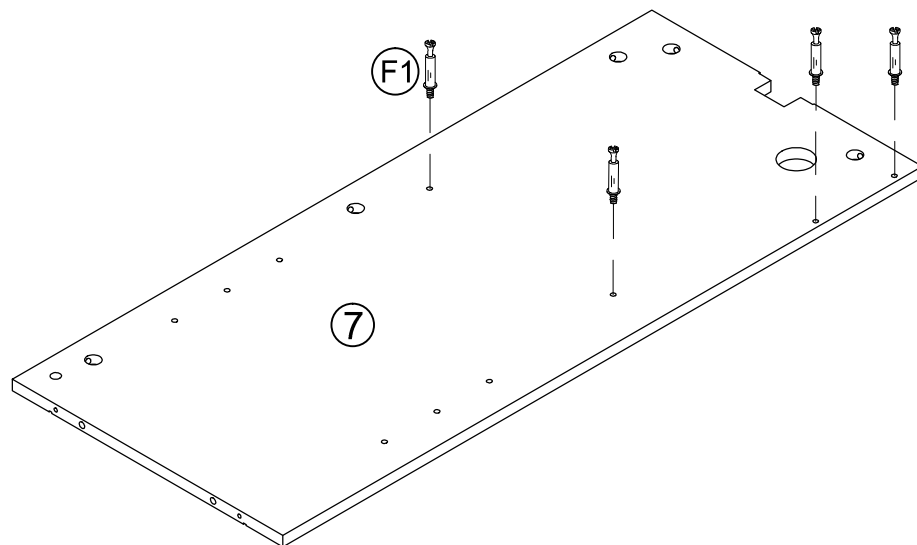

Step 9.



(C) X4



(F2) X10



(R) X6

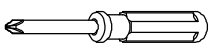

(Z)

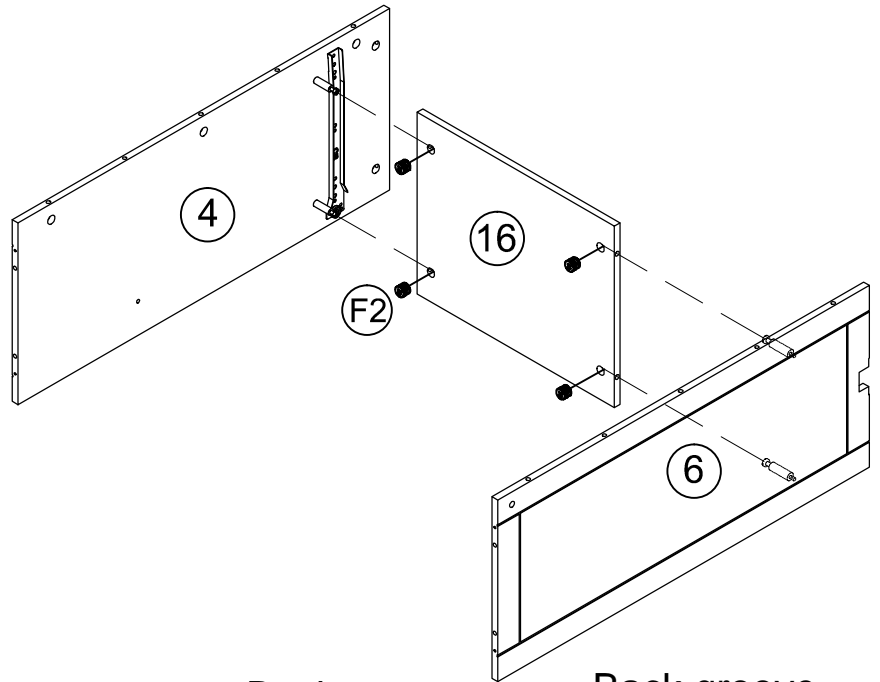

Back groove

Back groove

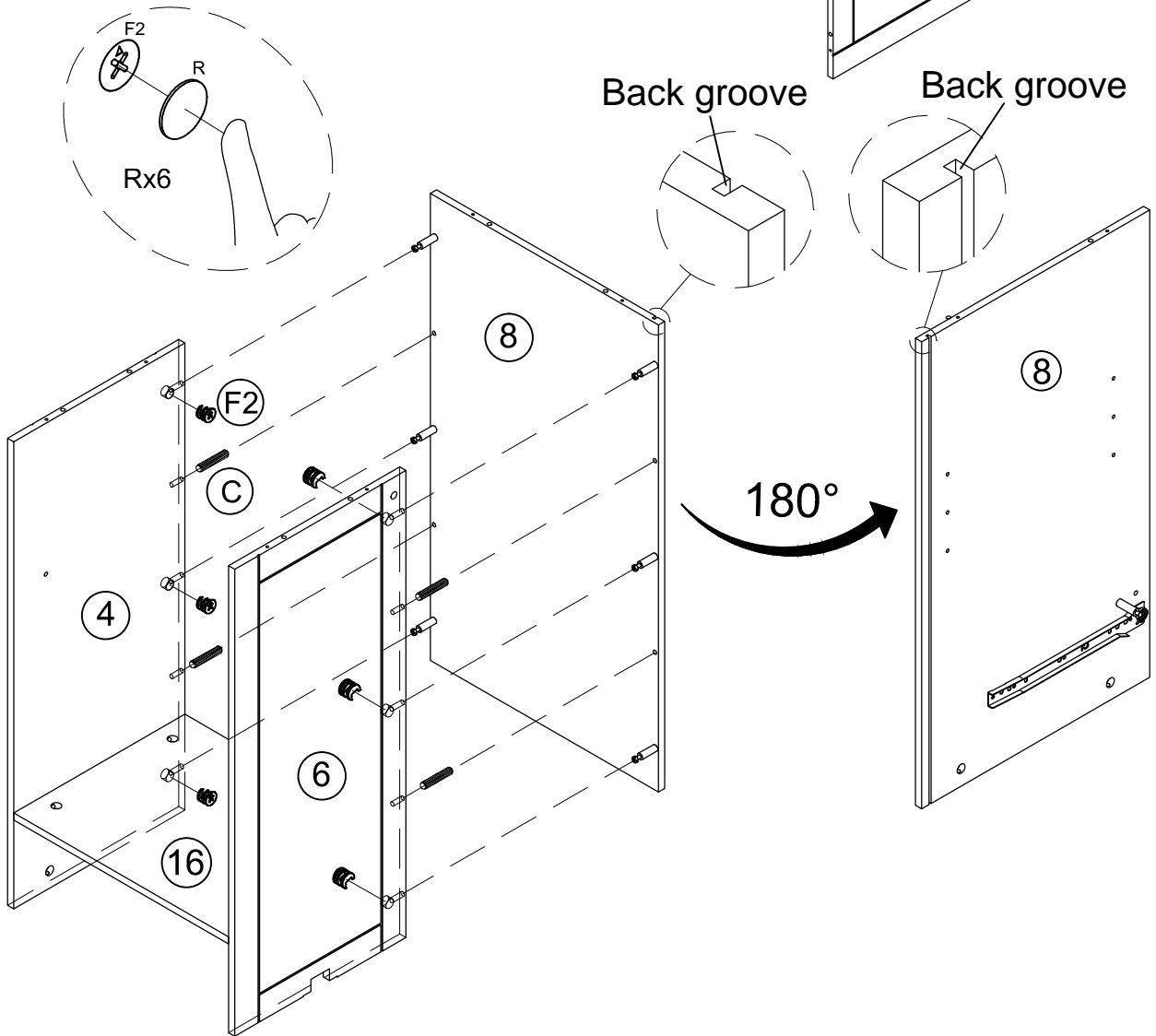

Step 10.



(C) X4



(F2) X14



(R) X6

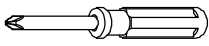

(Z)

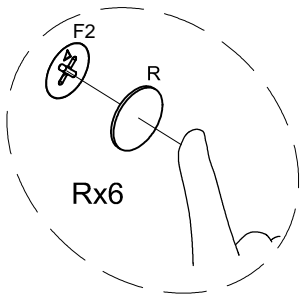
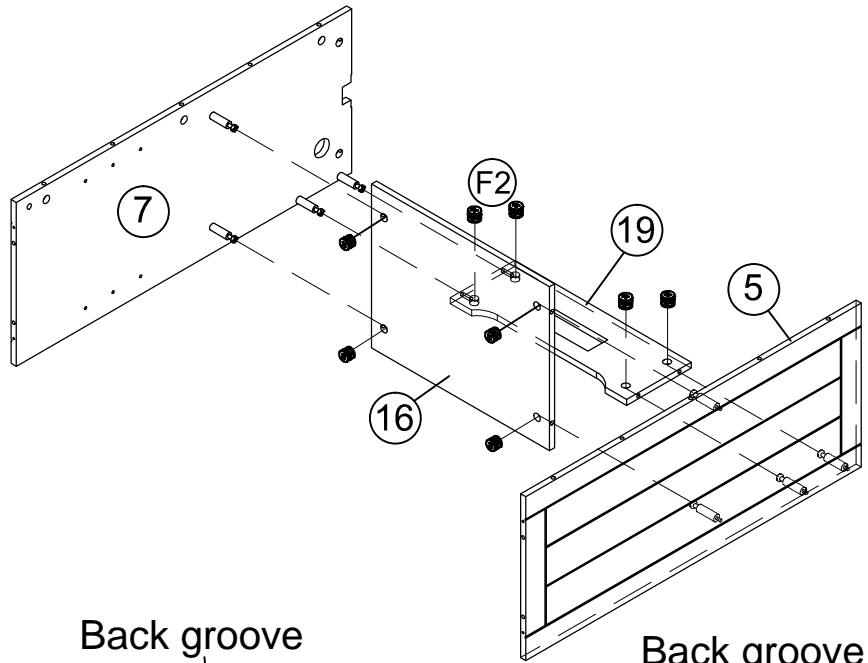

Back groove

Back groove

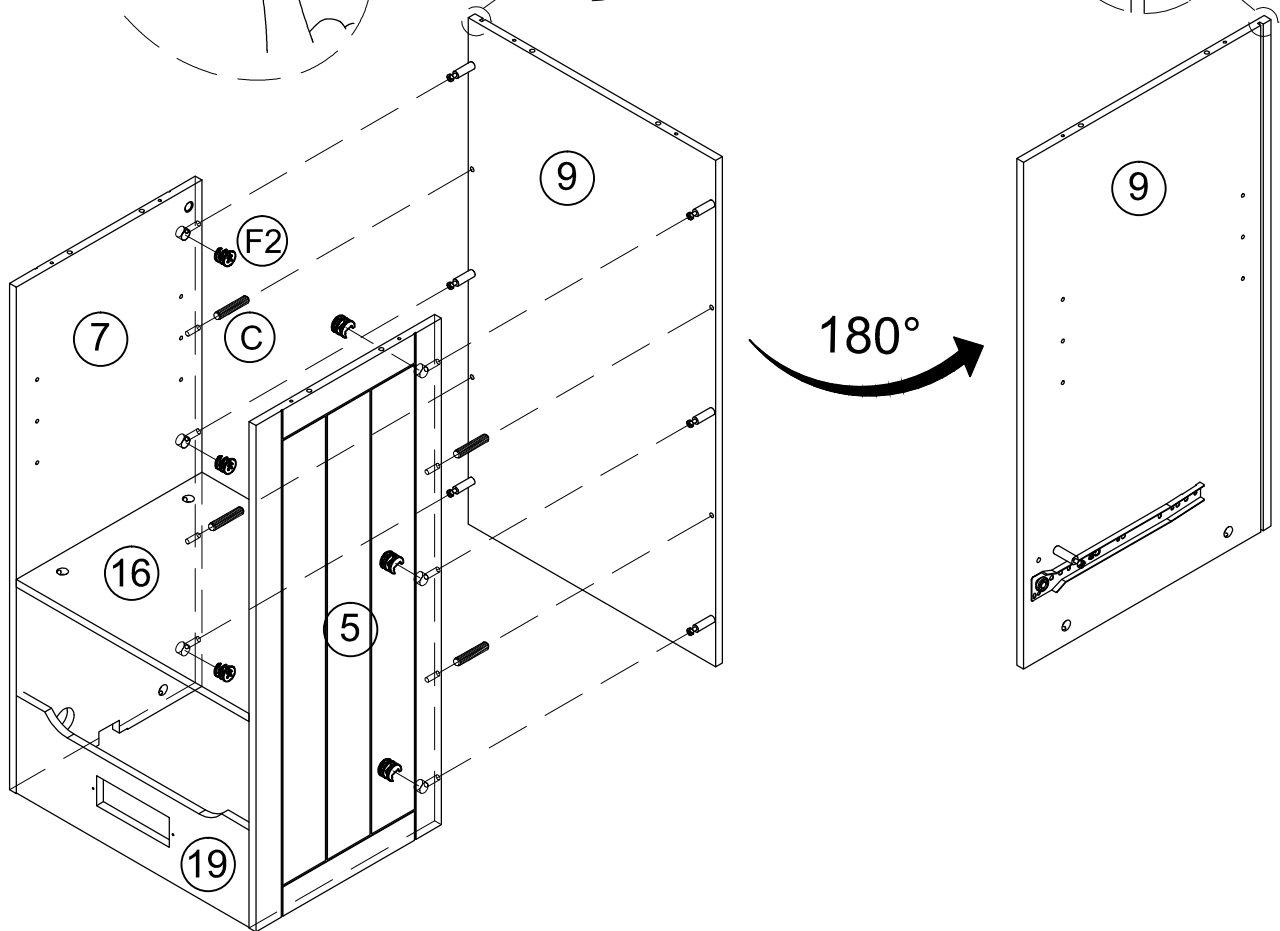

Step 11.

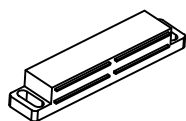

J1 X1



J2 X2



C X2

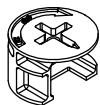

F2 X2

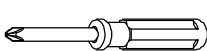

Z

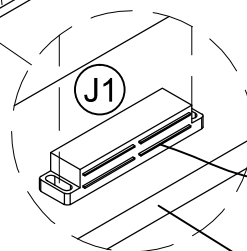
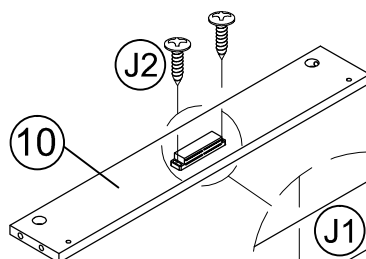

Magnet in front

Front edge

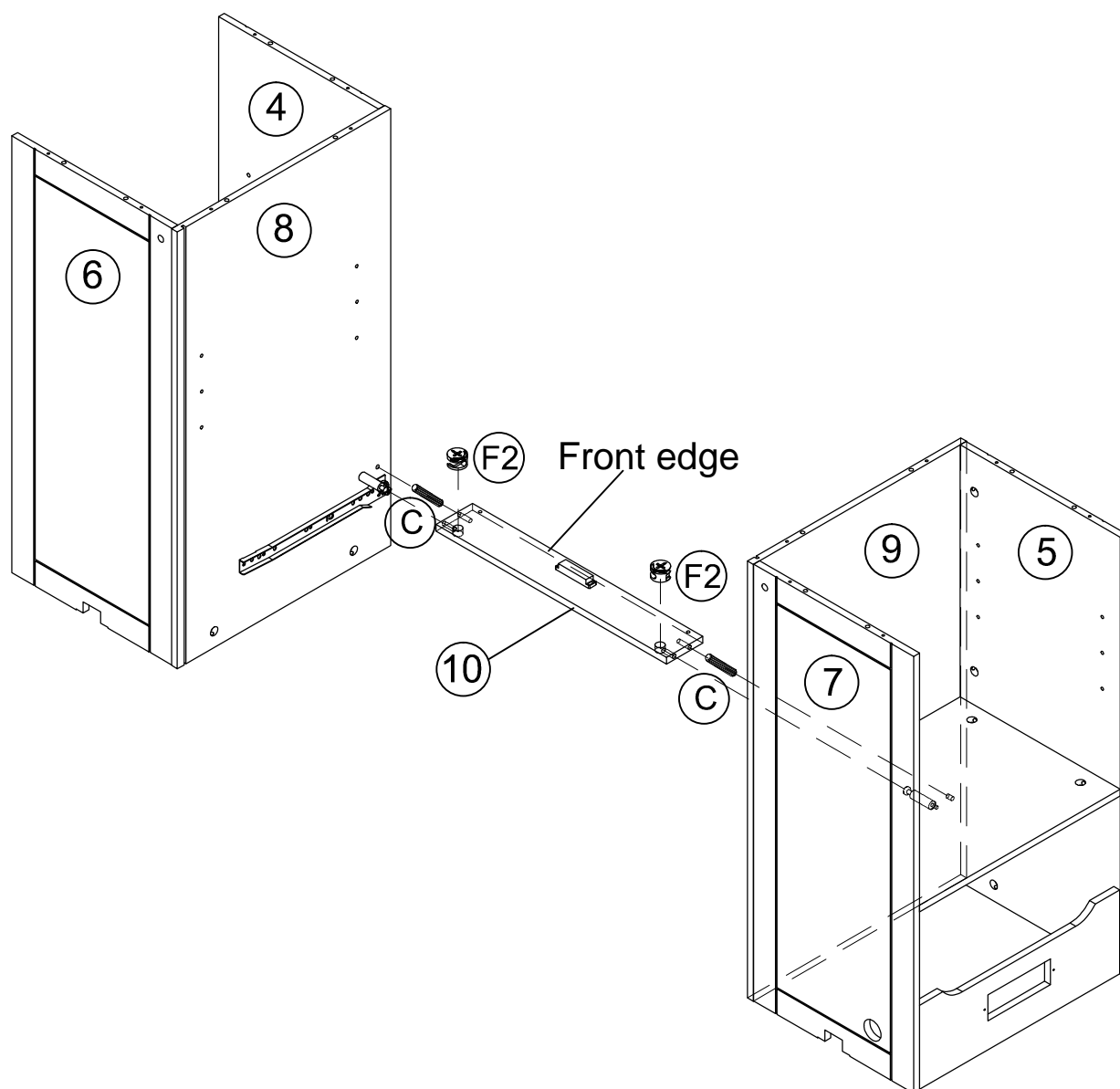

Step 12.



(B) X12



(C) X12



(Z)

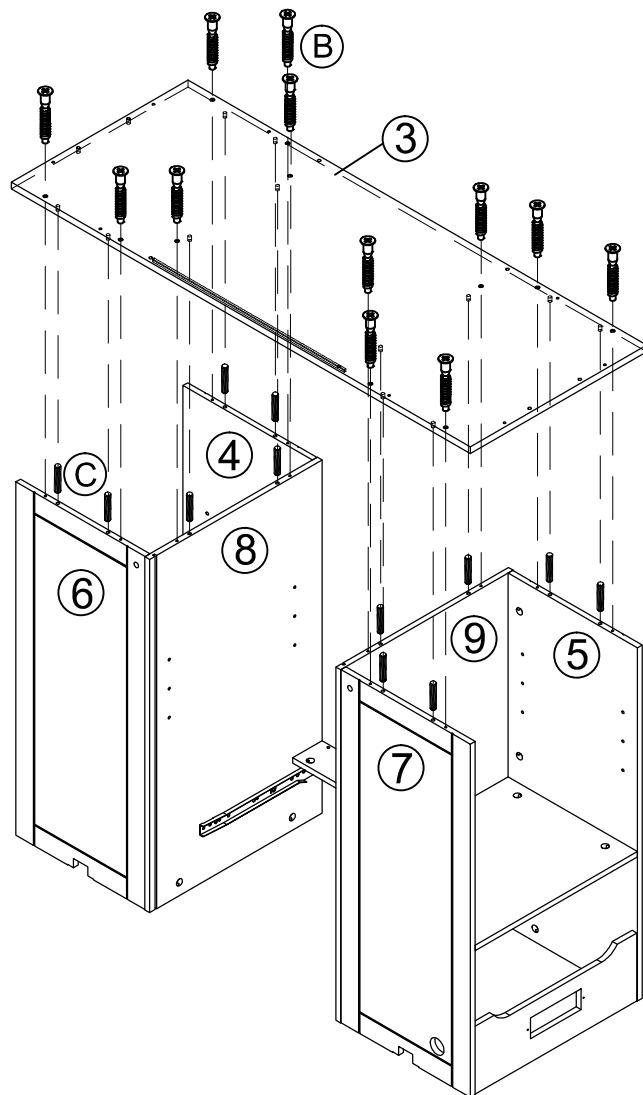

Step 13.

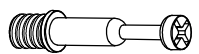

(F1) X8

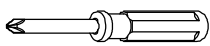

(Z)

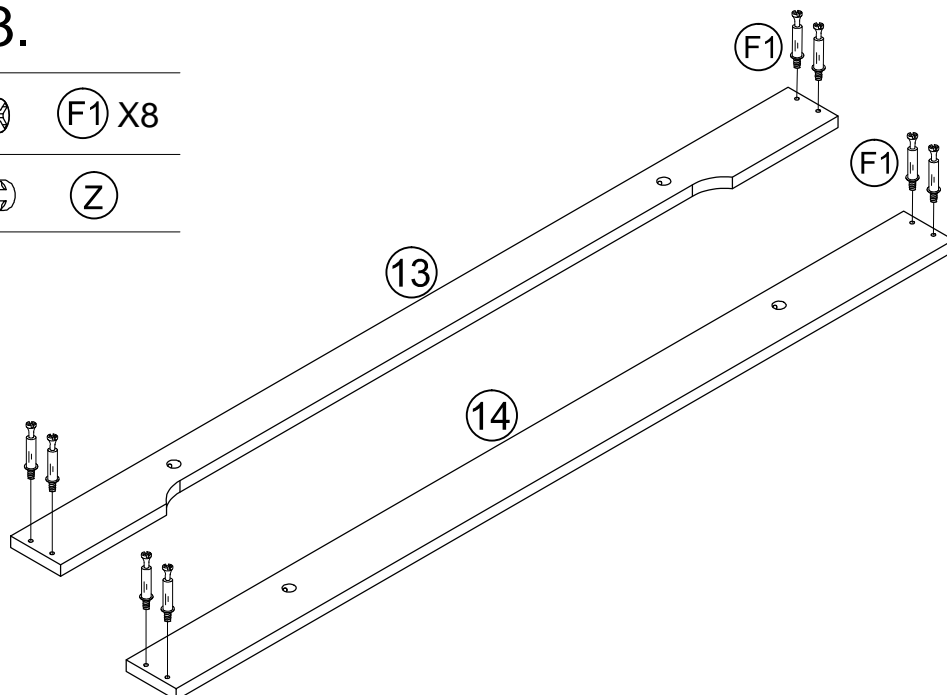

Step 14.



(F2) X8

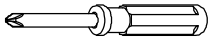

(Z)

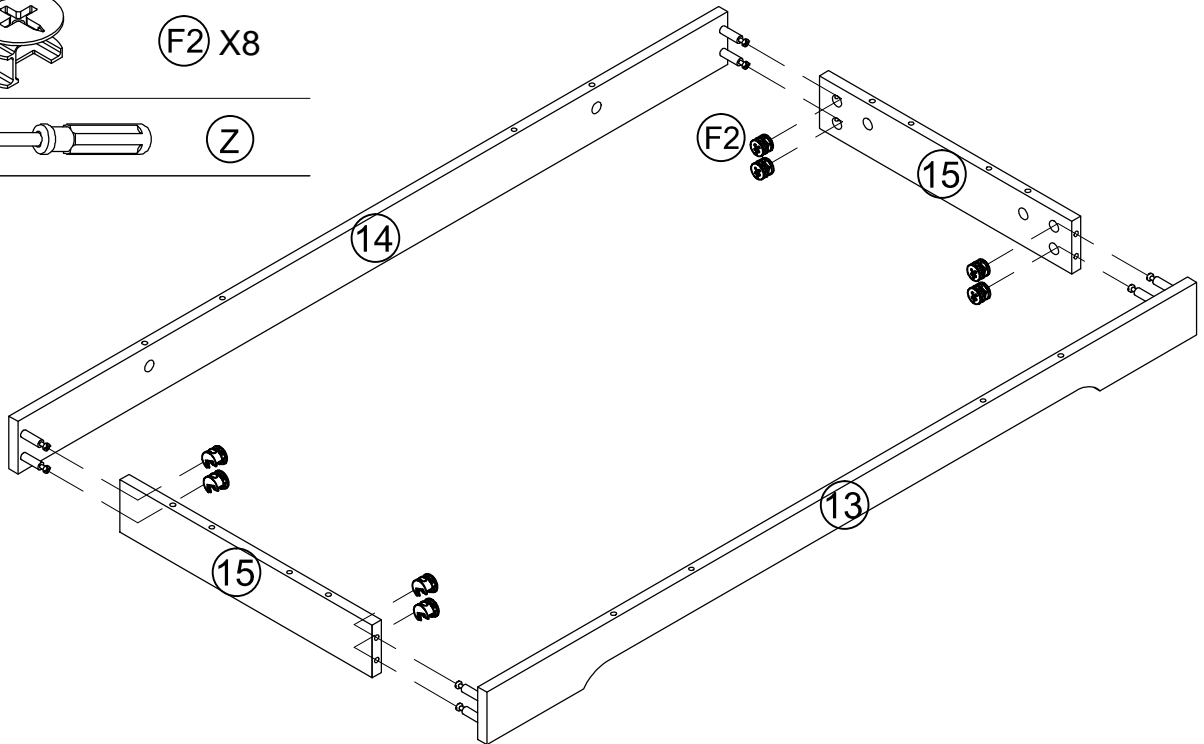

Step 15.

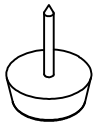

(U) X8

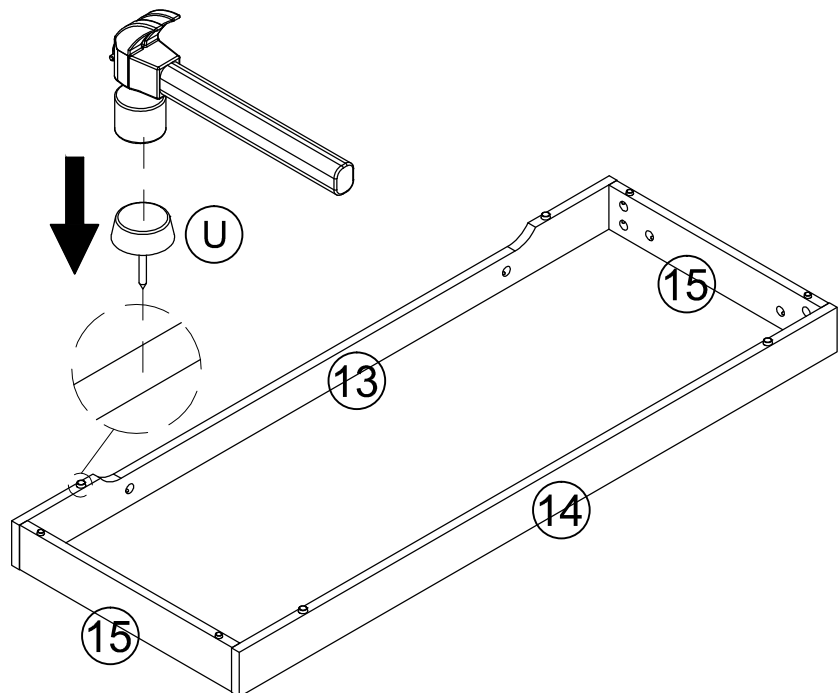
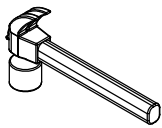

Step 16.

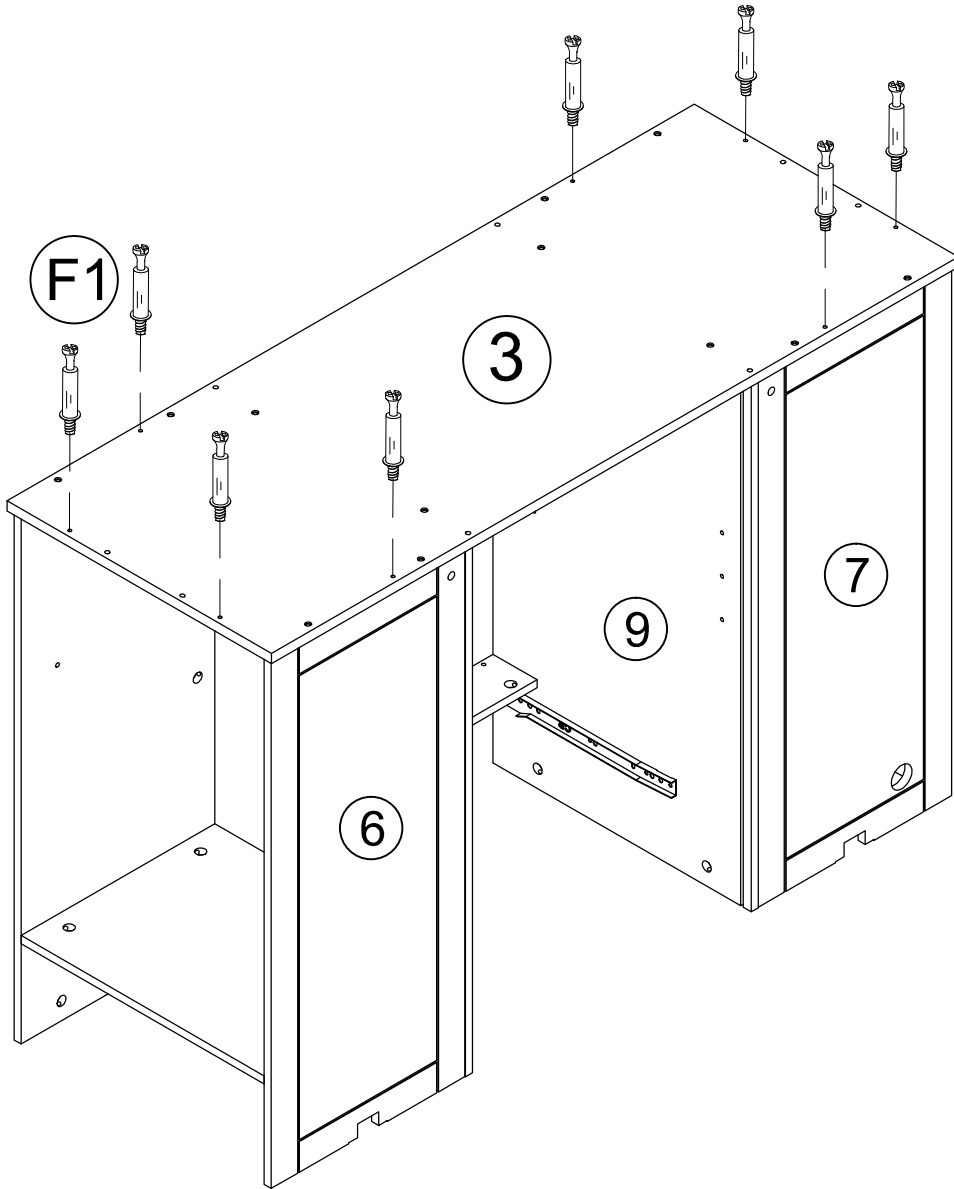
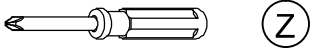
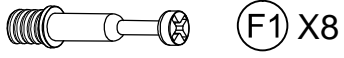

Step 17.

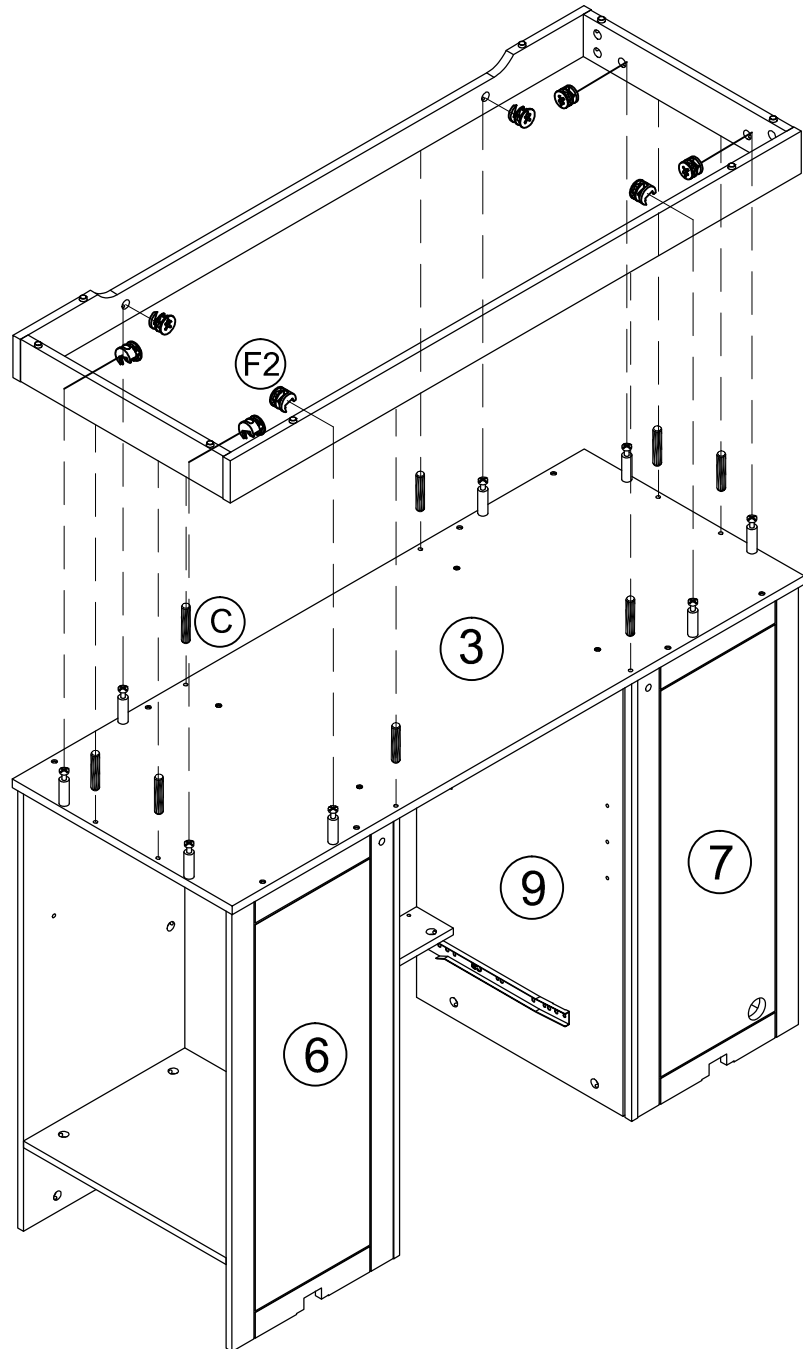
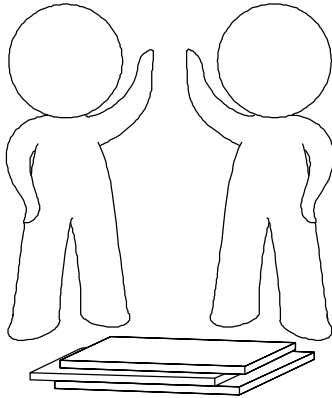
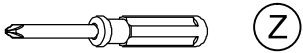
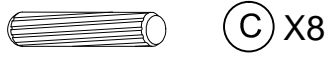

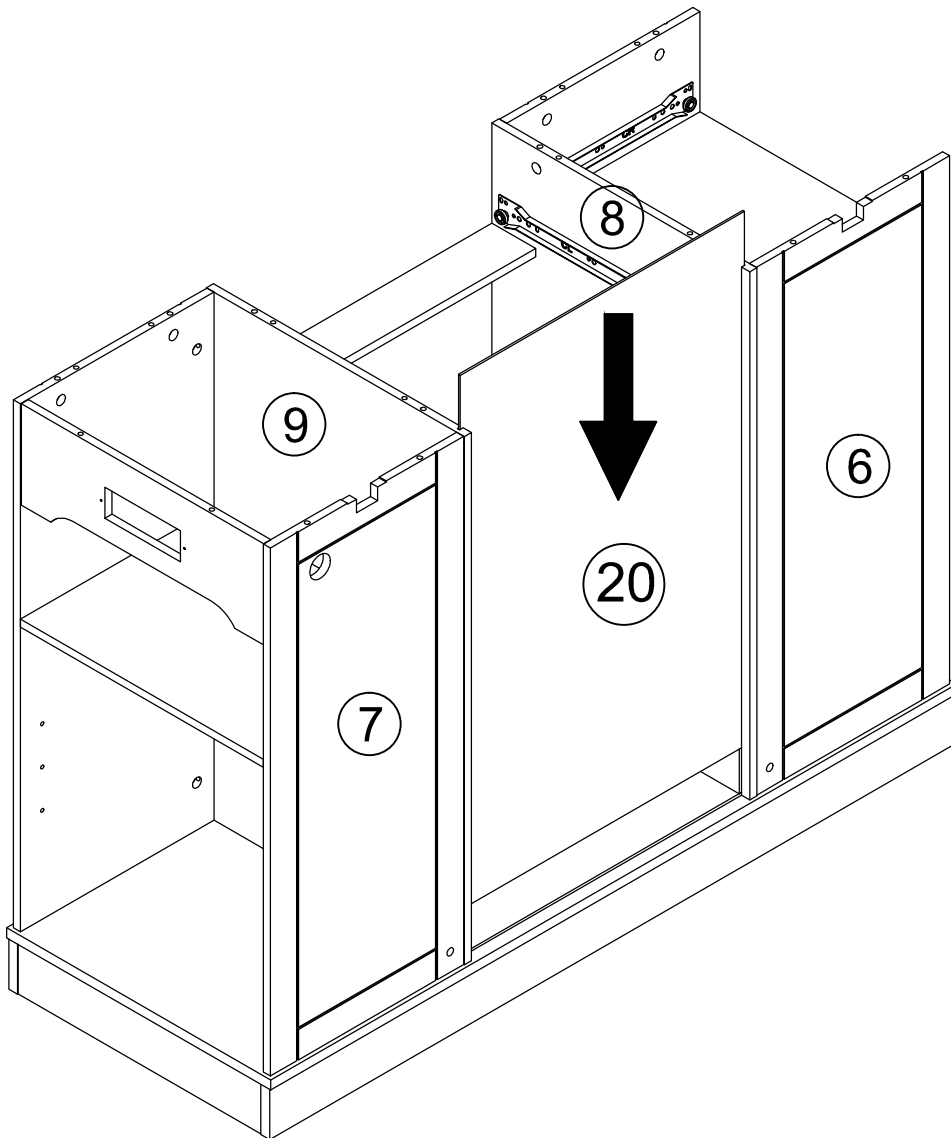
Step 18.

Step 19.

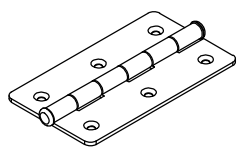

(S) X3



(O) X18

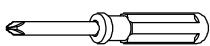

(Z)

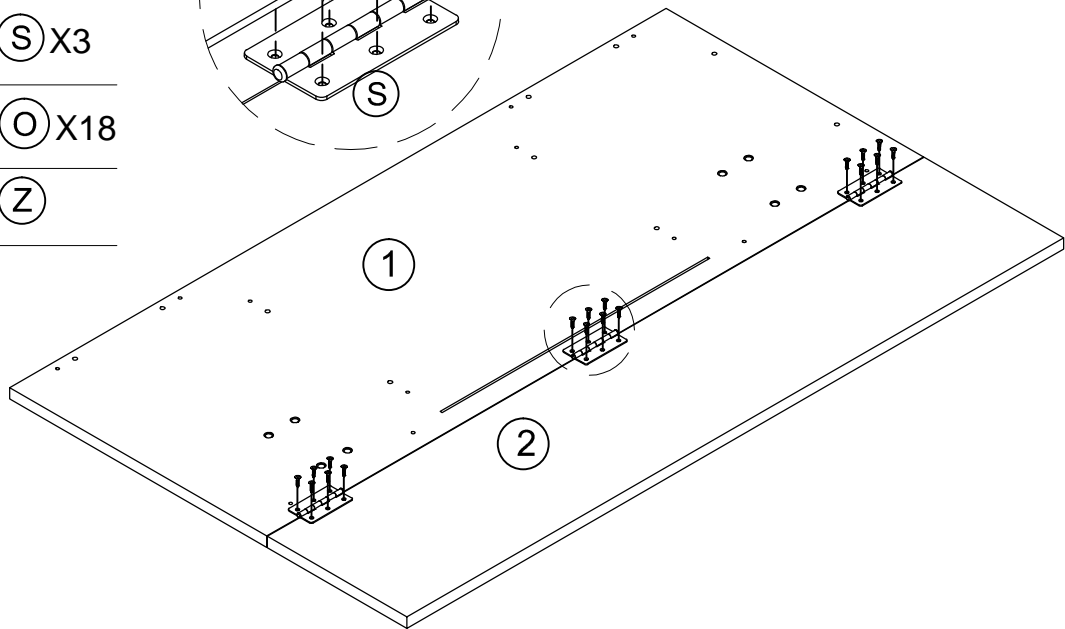
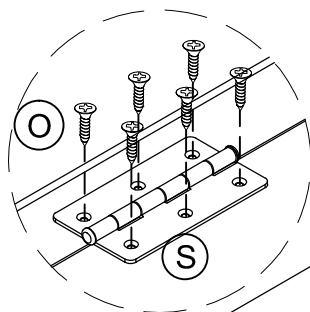

Step 20.



(A) X1

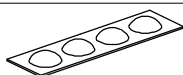

(Y) X4



(V) X8

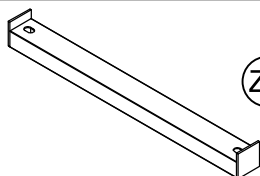

(ZA) X2

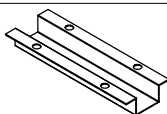

(ZB) X2

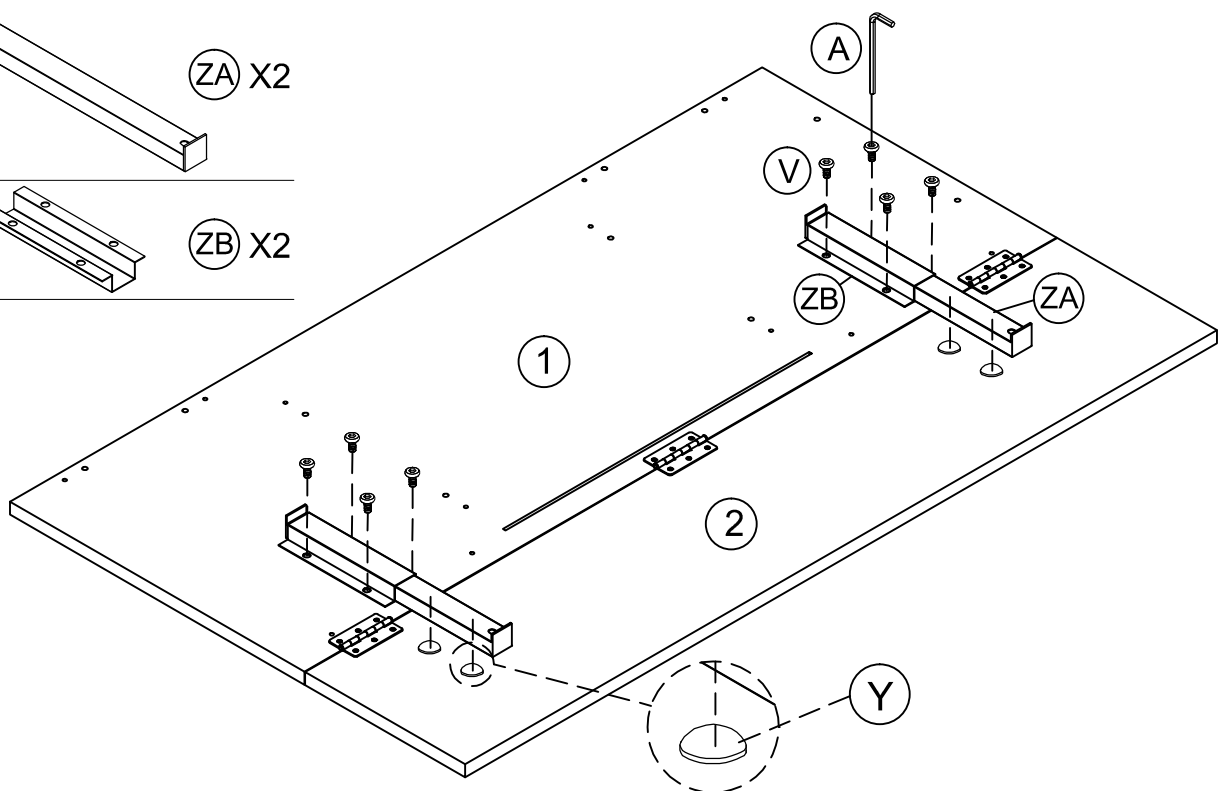

Step 21.

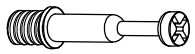

(F1) X12

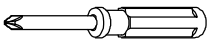

(Z)

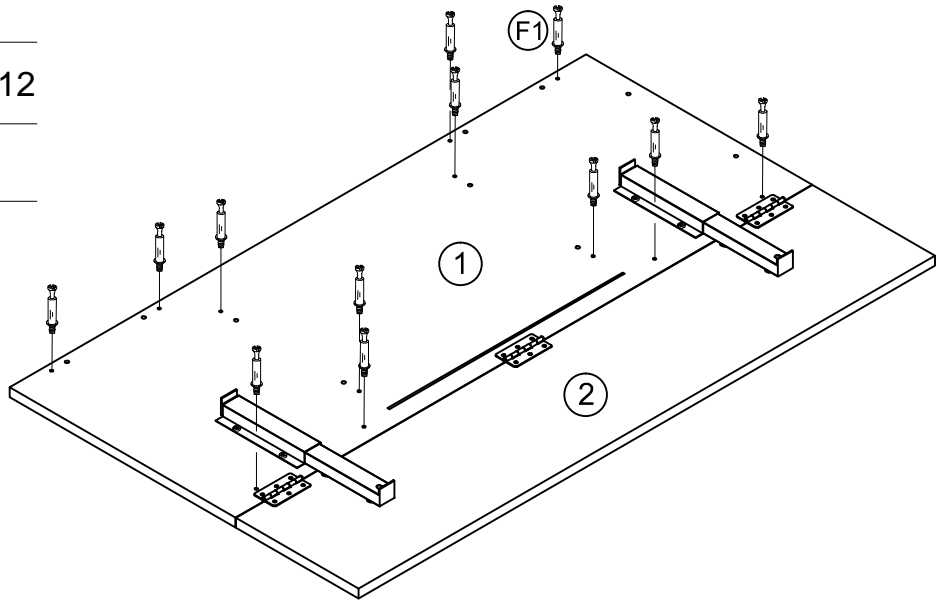

Step 22.



(C) X10



(F2) X12



(R) X12



(Z)

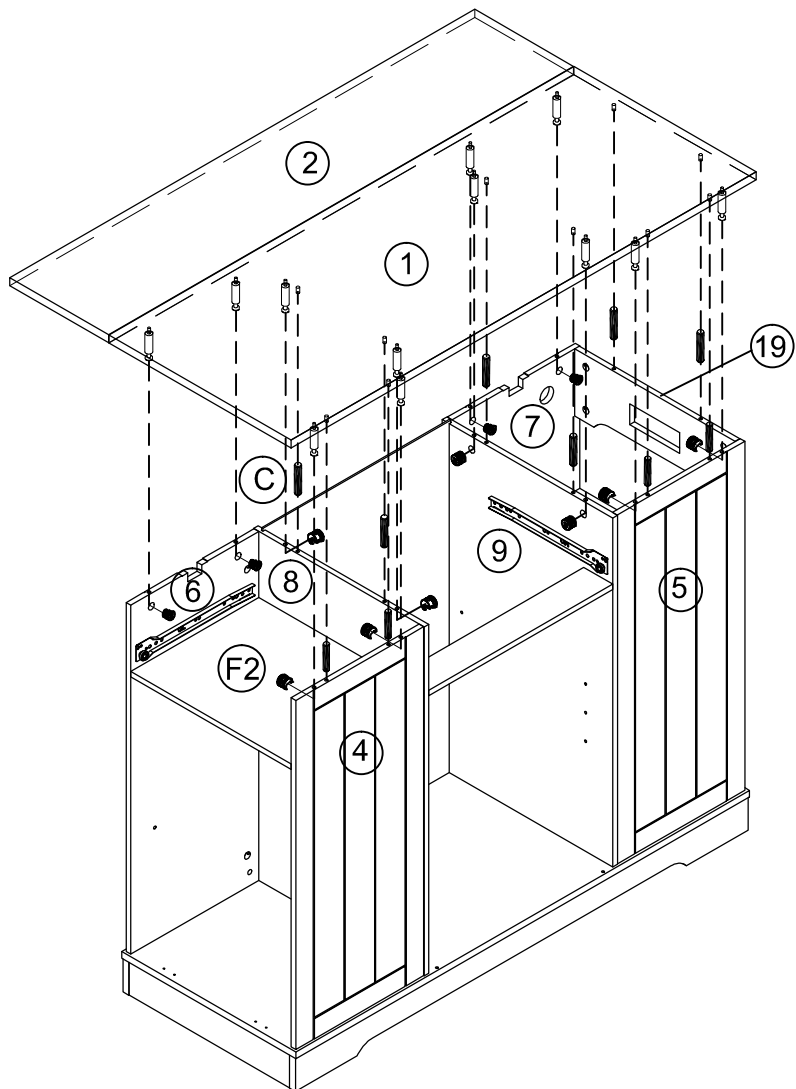
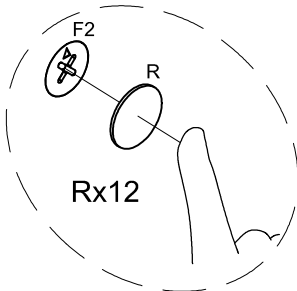
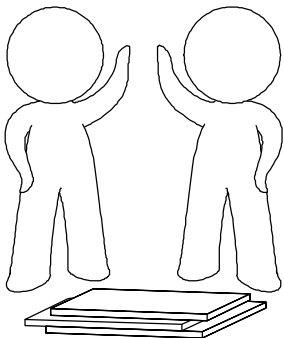

Step 23.

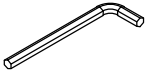

ZE X1

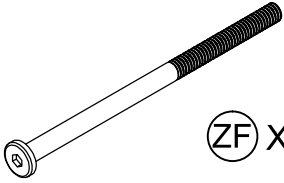

ZF X2

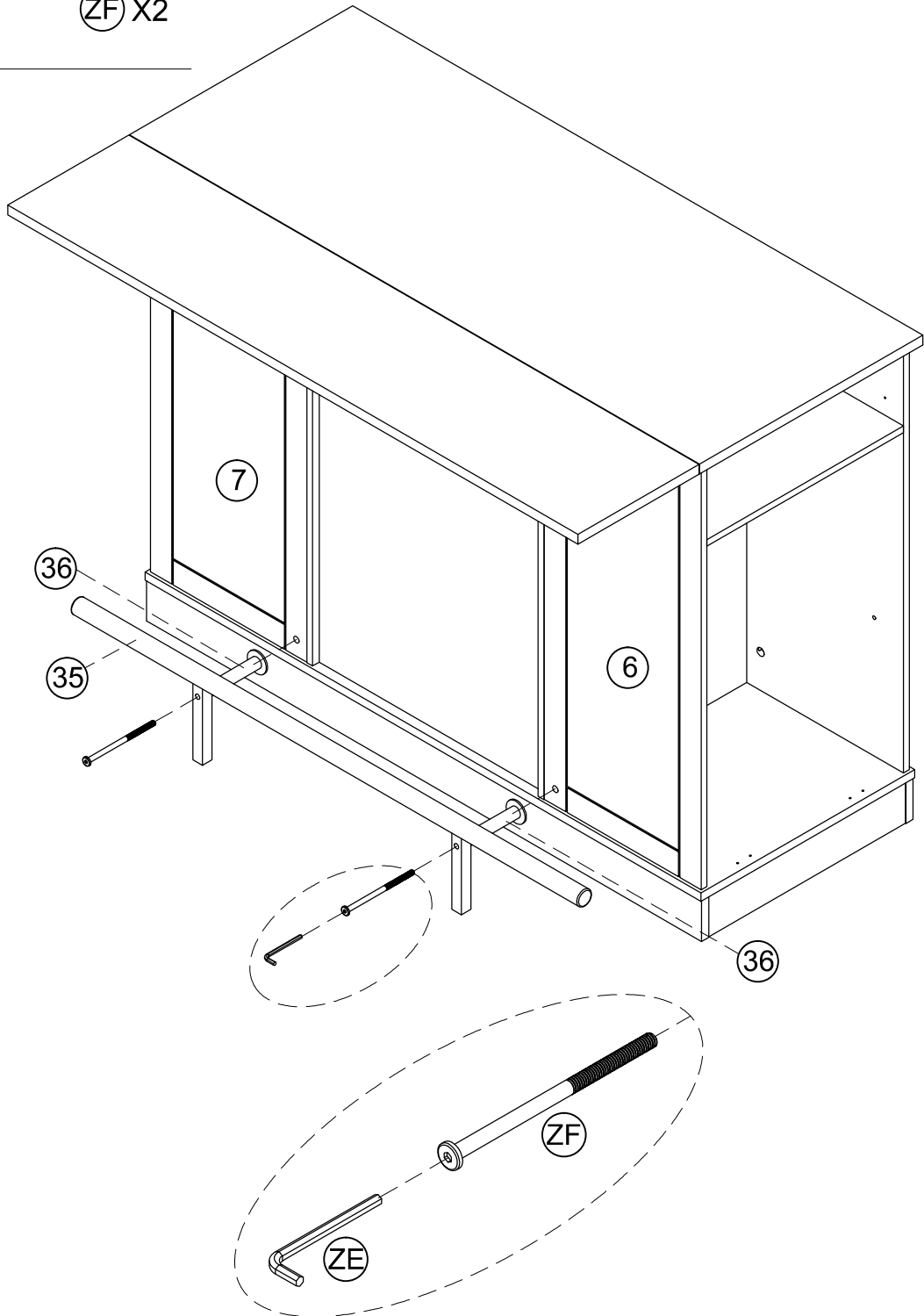

Step 24.

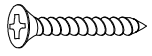

(E) X4

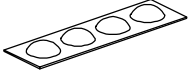

(Y) X4



(Z)

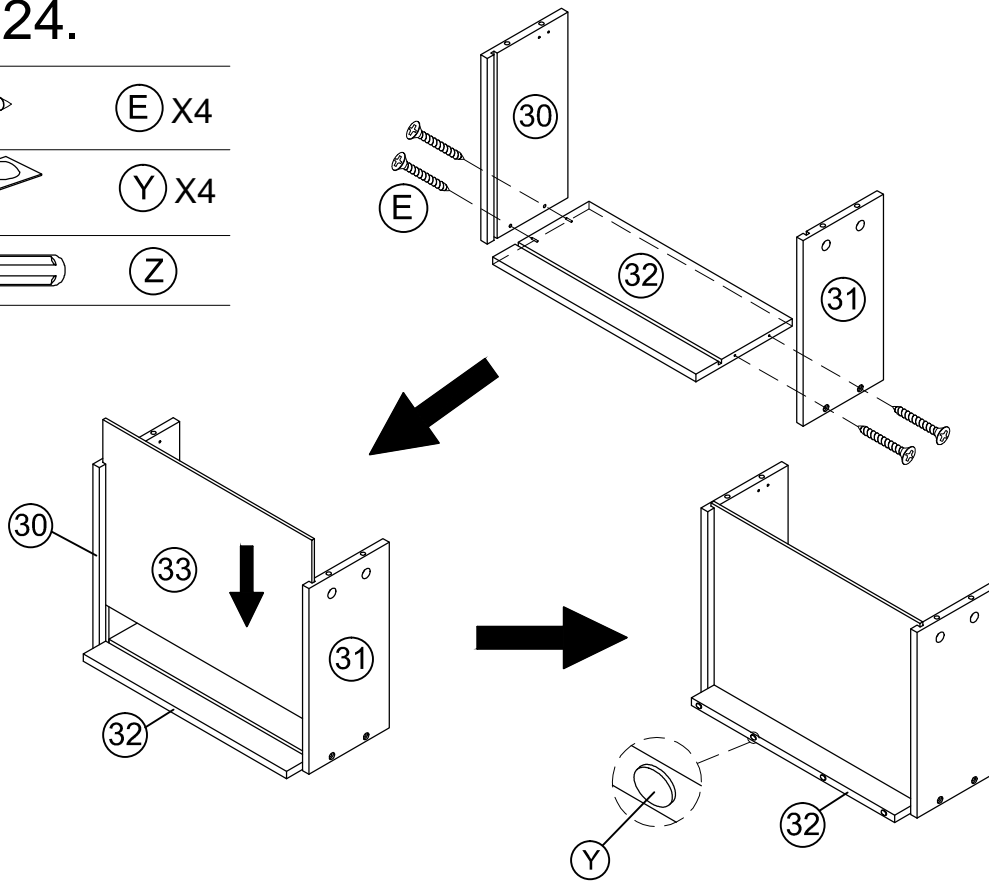

Step 25.

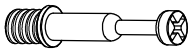

(F1) X4

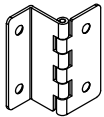

(M1) X2



(M2) X4

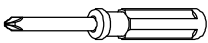

(Z)

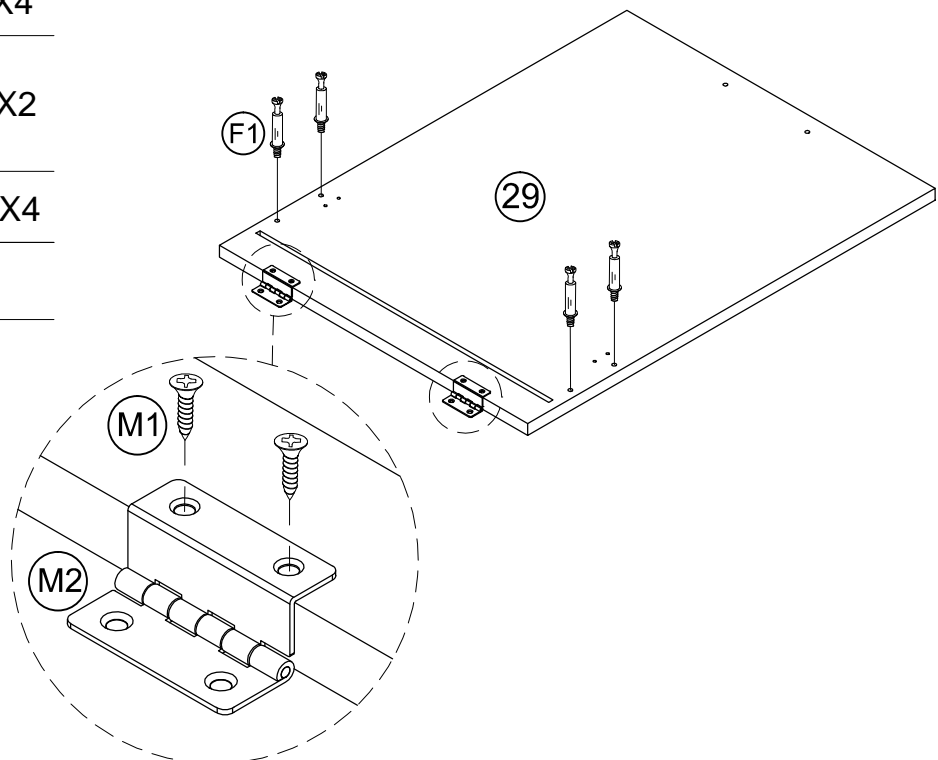

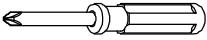

Step 26.

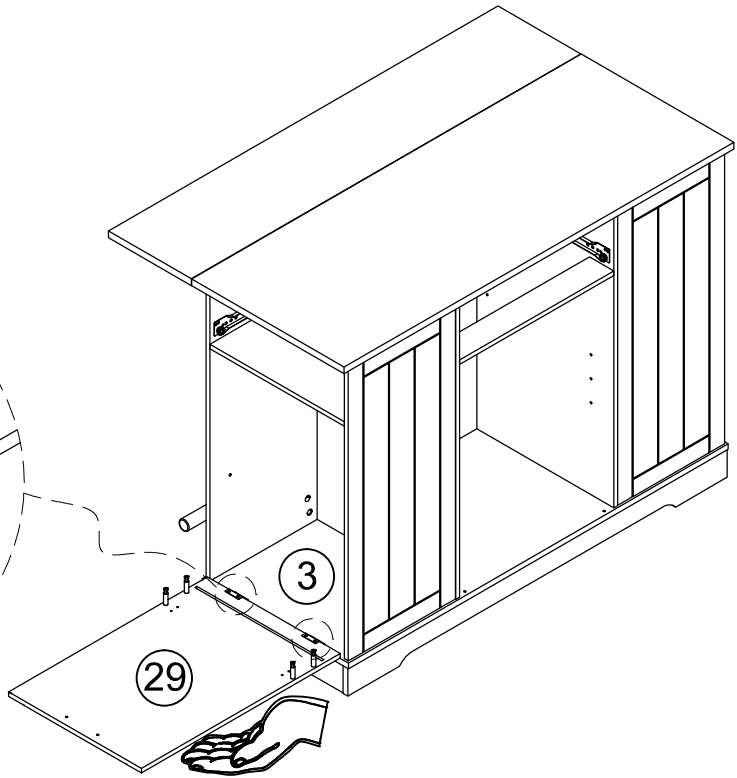
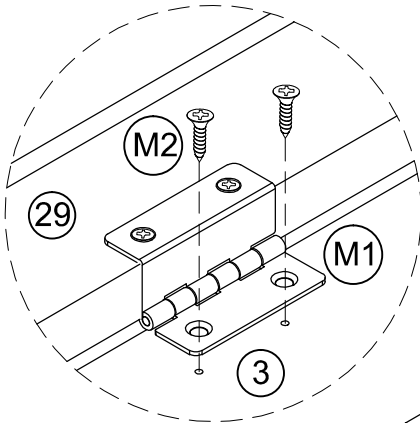
-  (M2) X4
-  (Z)



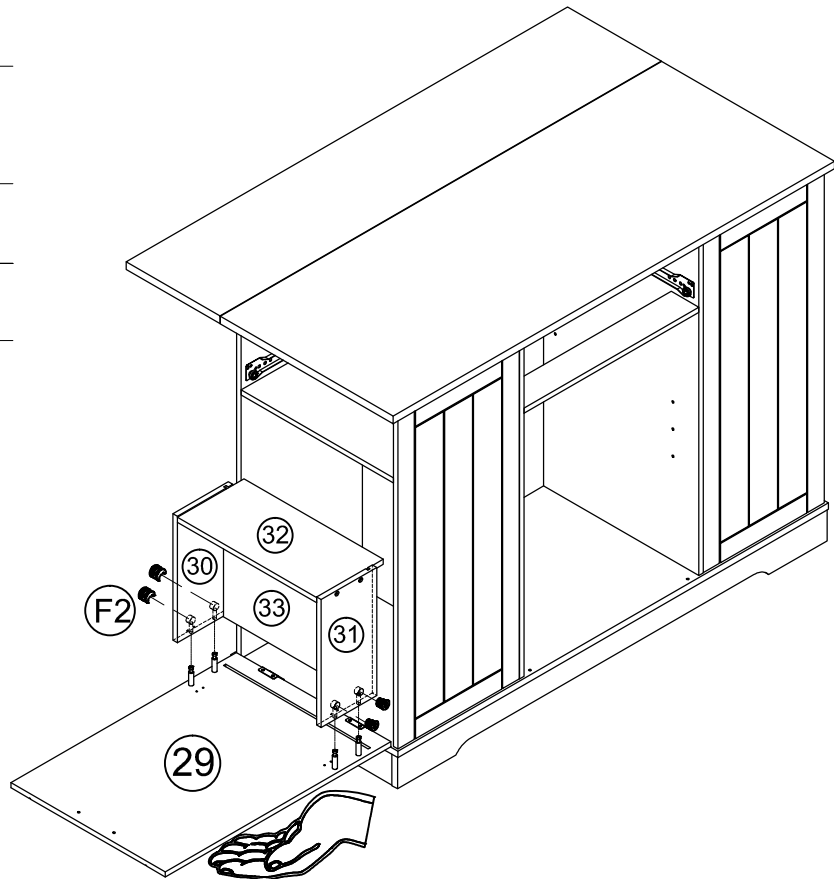
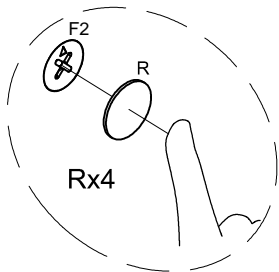

Step 27.

-  (F2) X4
-  (R) X4
-  (Z)



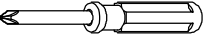

Step 28.

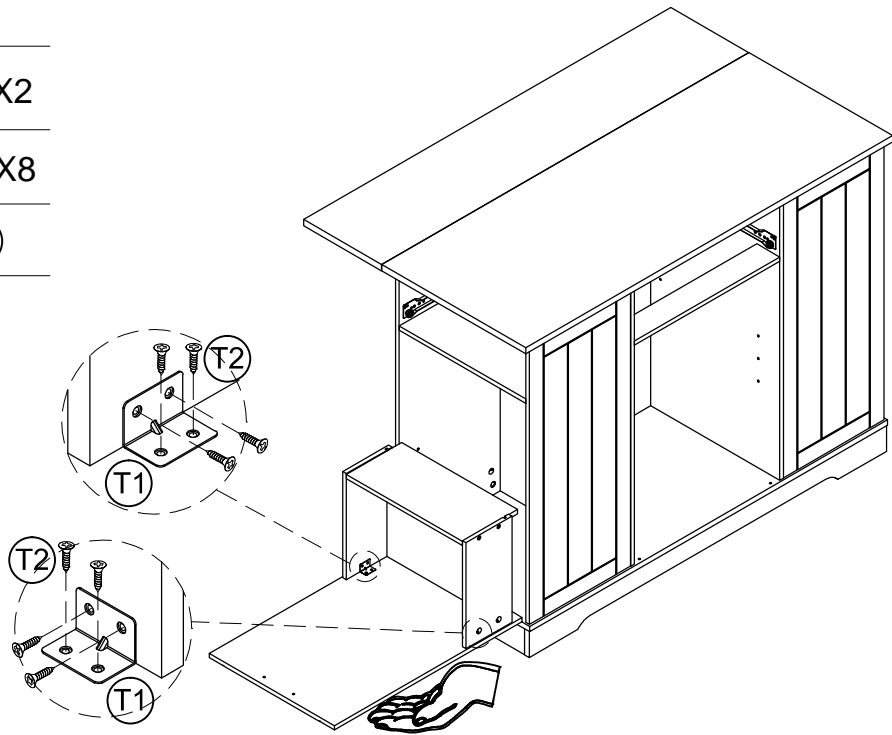
-  (T1) X2
-  (T2) X8
-  (Z)

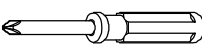

Step 29.

-  (D1) X1
-  (D2) X2
-  (P) X2
-  (Z)

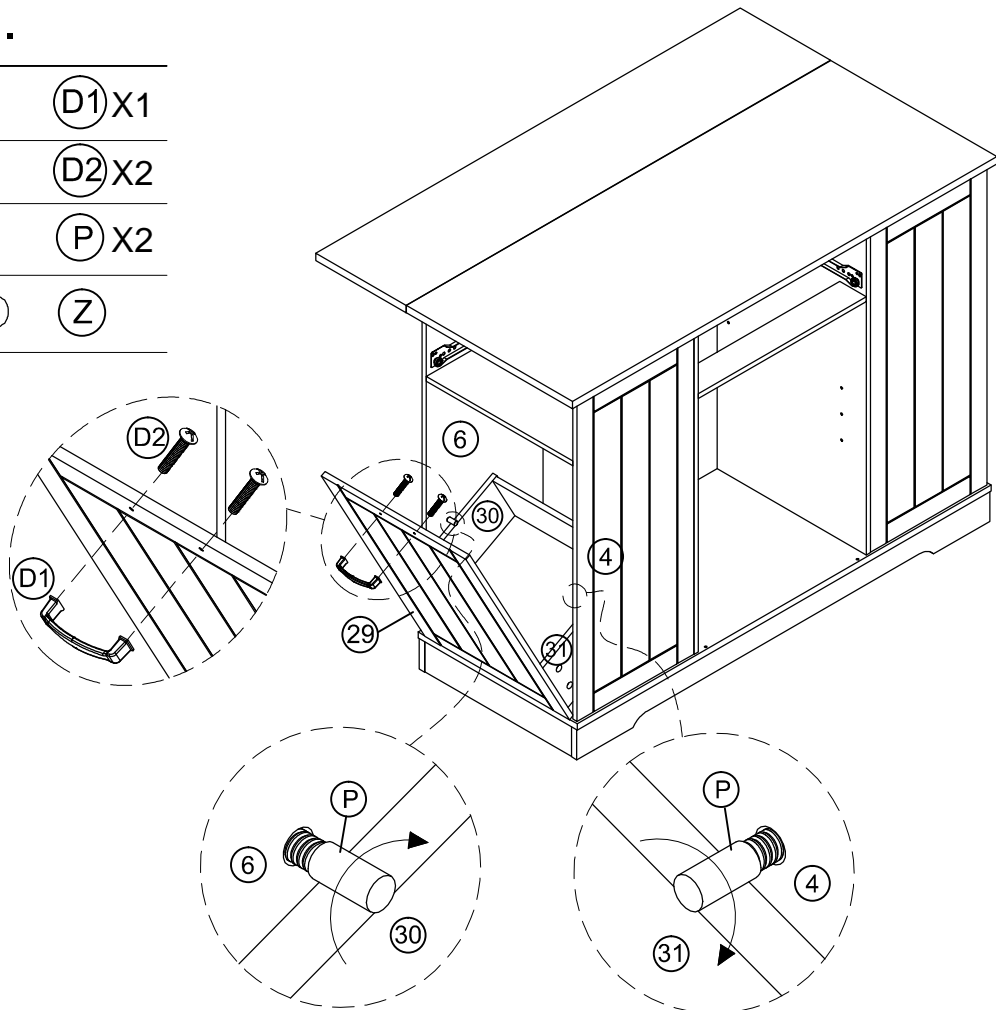

Step 30.

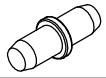

Q x4

Adjustable for three heights.
The shelf can be adjusted up and down with three heights.

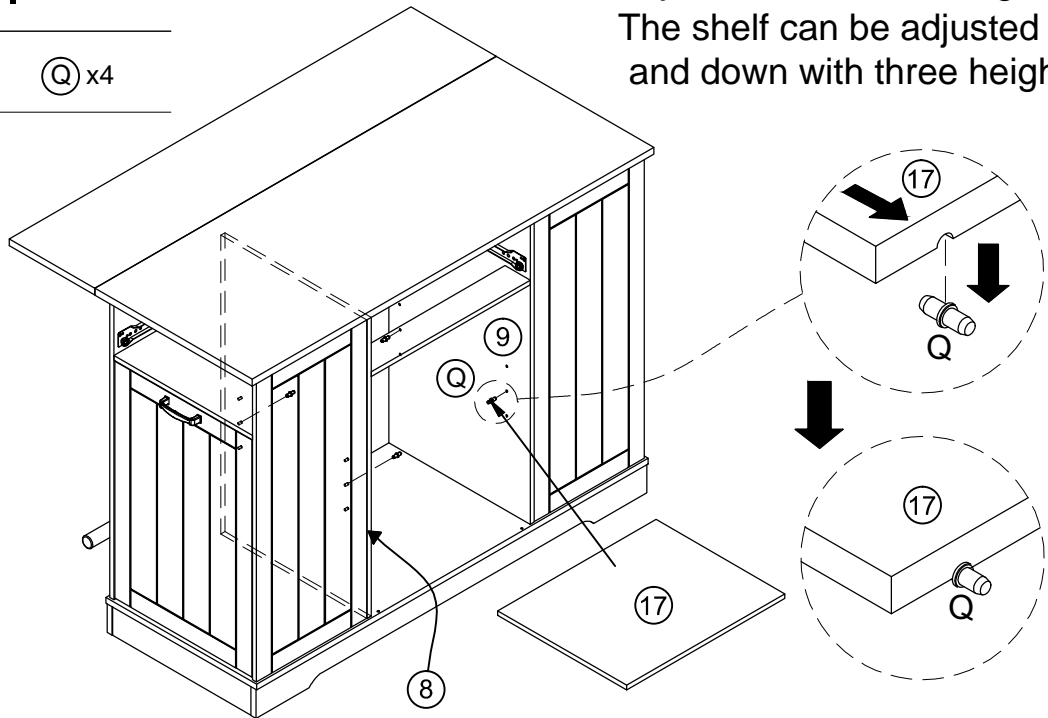

Step 31.



K1 x2



K2 x2



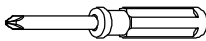

ZC x4

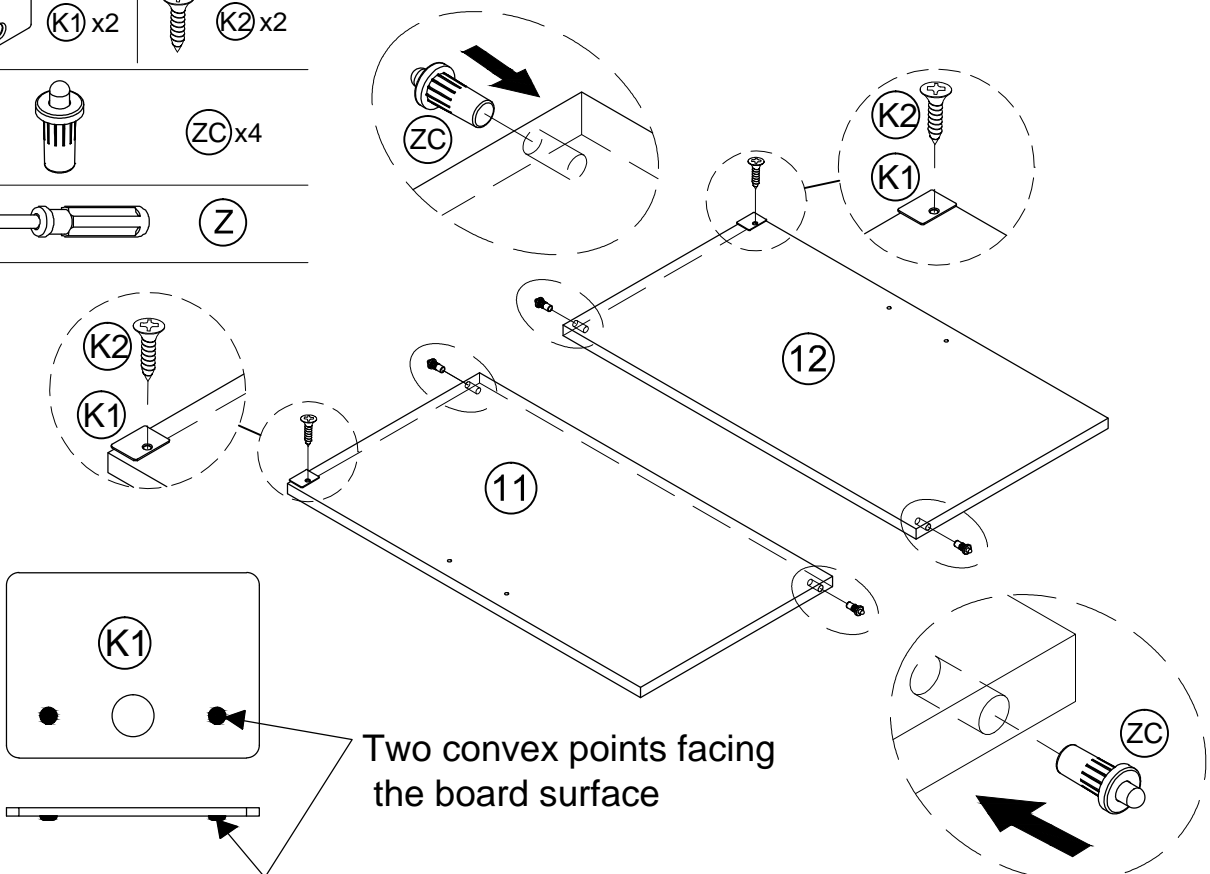

Z

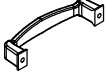

Step 32.

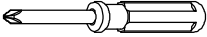
-  (D1) X2
-  (D2) X4
-  (Z)

PIN PIVOT CAVITY

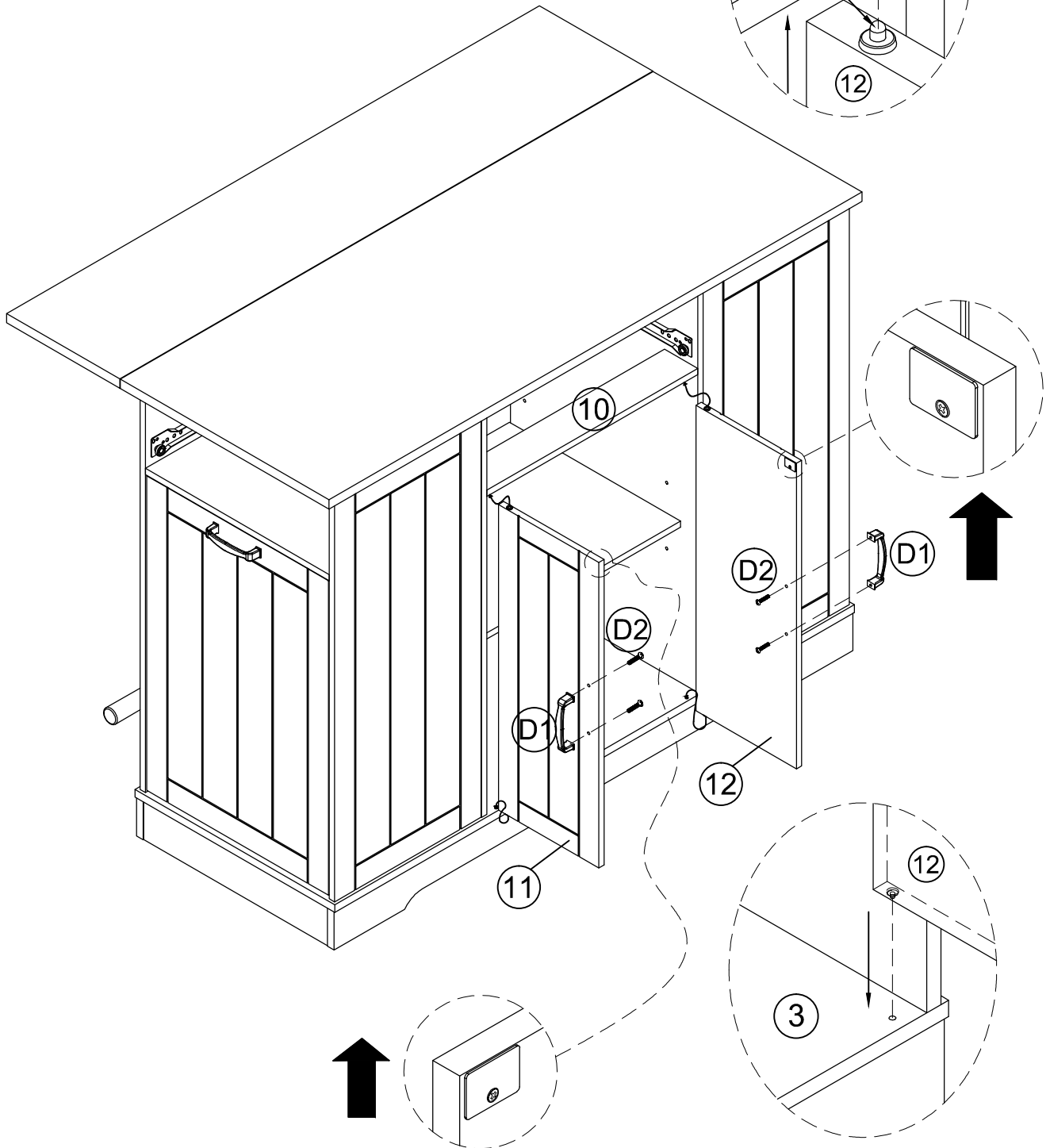
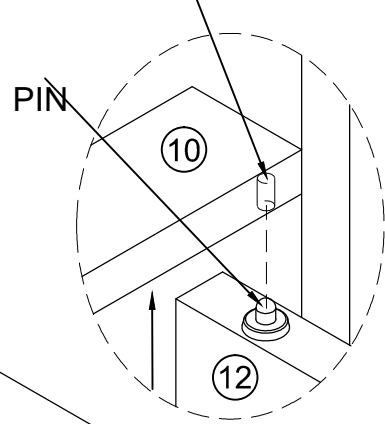

Step 33.

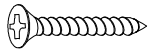

(E) X4

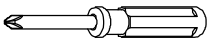

(Z)

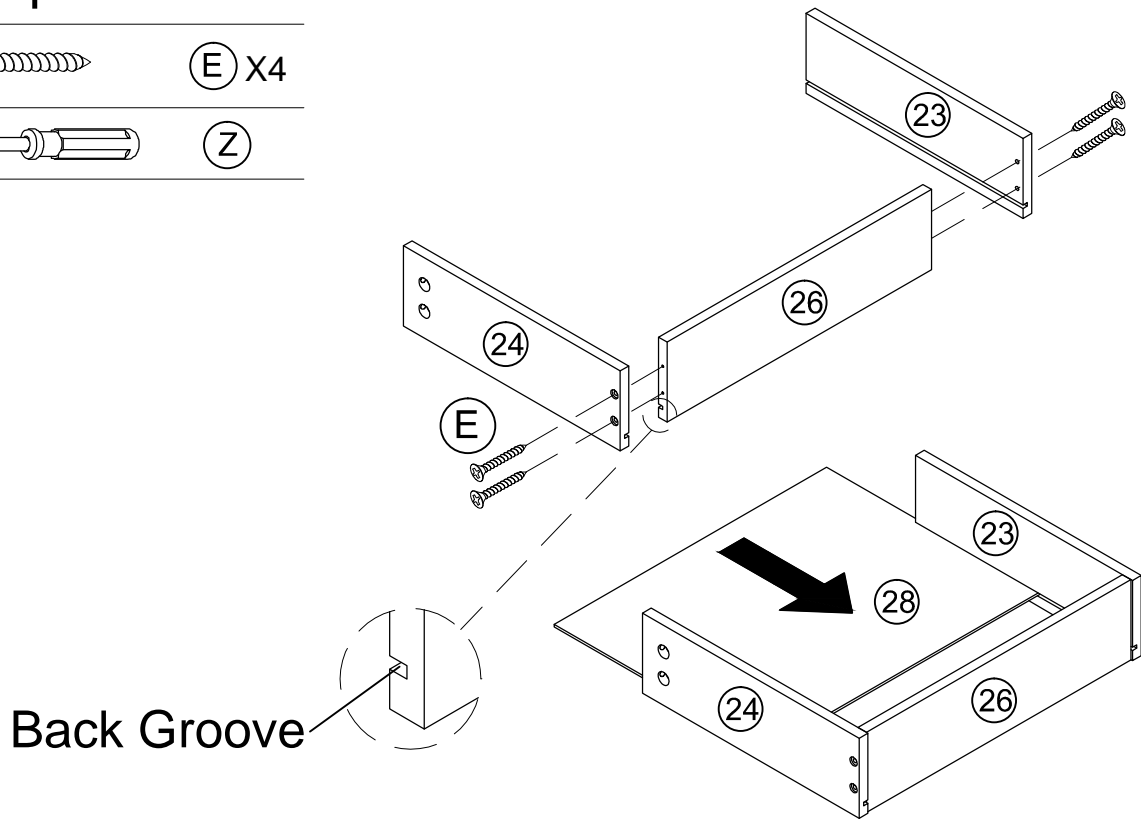

Step 34.

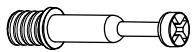

(F1) X4



(F2) X4

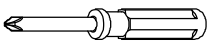

(Z)

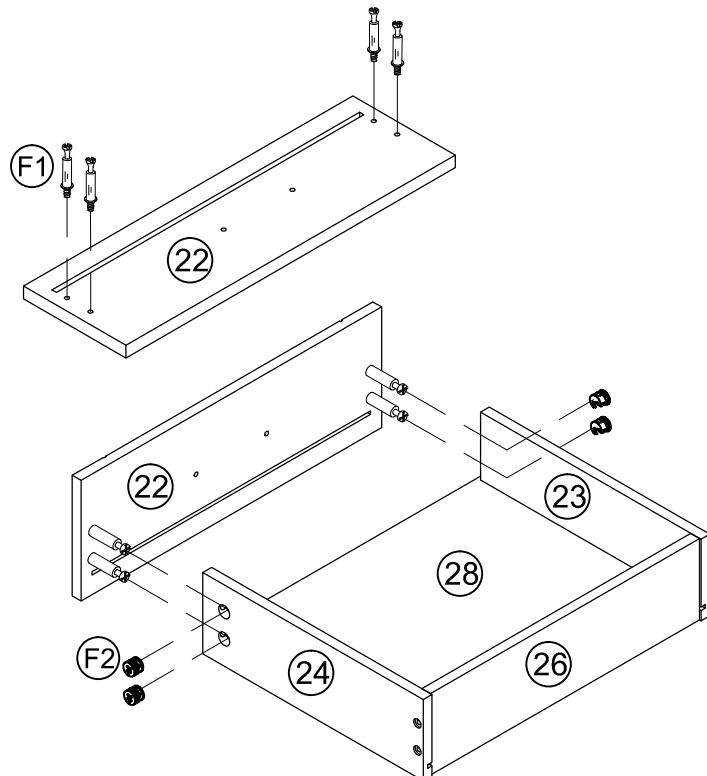

Step 35.

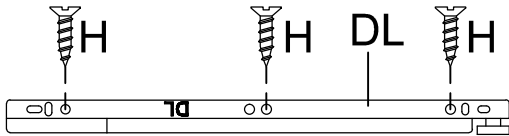
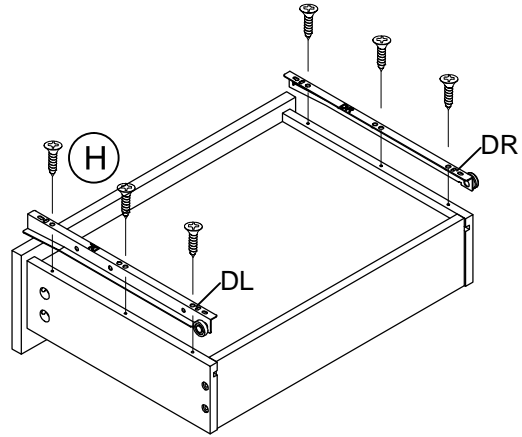
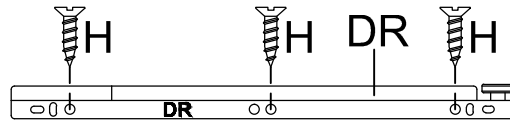
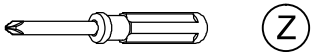
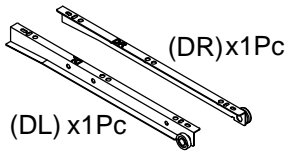

Step 36.

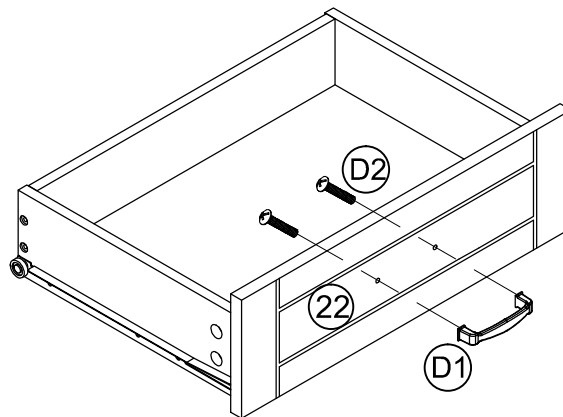
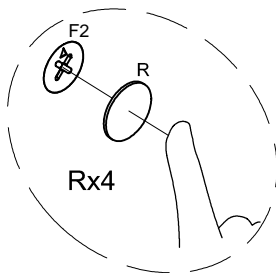
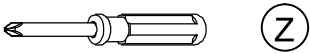

Step 37.

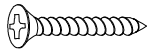

(E) X4

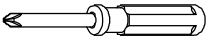

(Z)

Back Groove

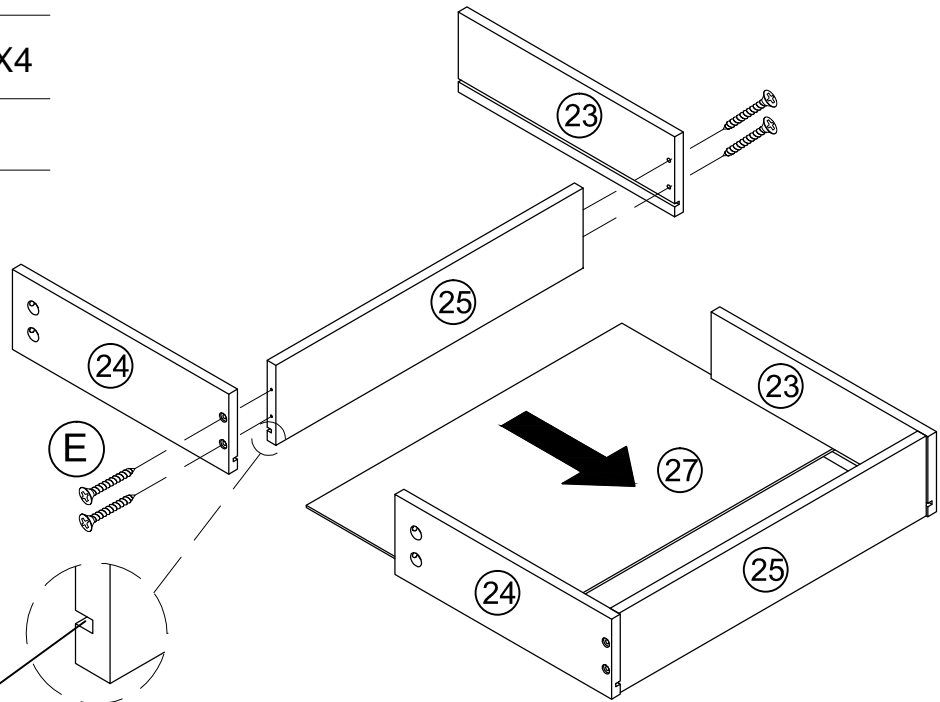

Step 38.

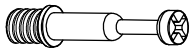

(F1) X4



(F2) X4

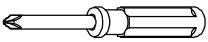

(Z)

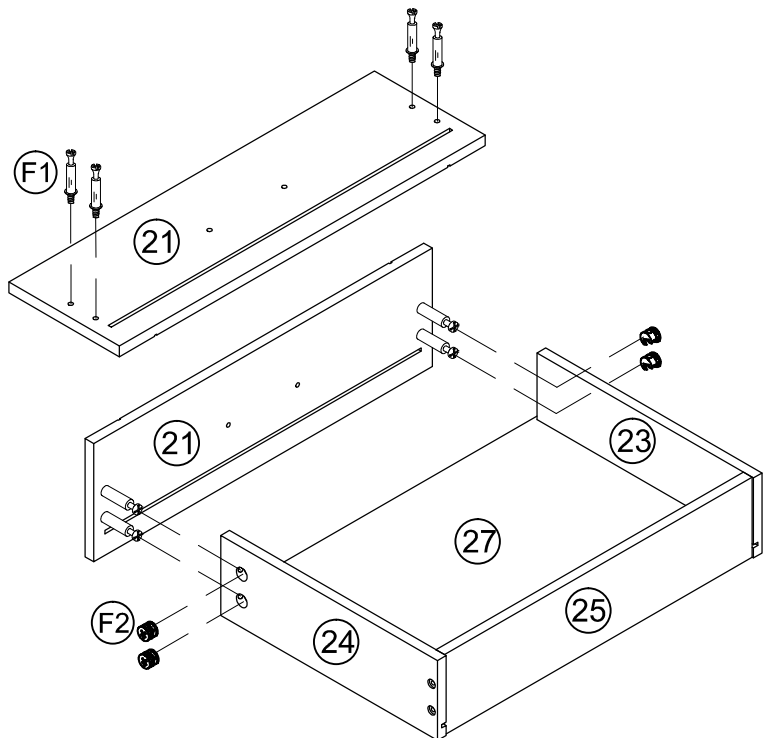

Step 39.

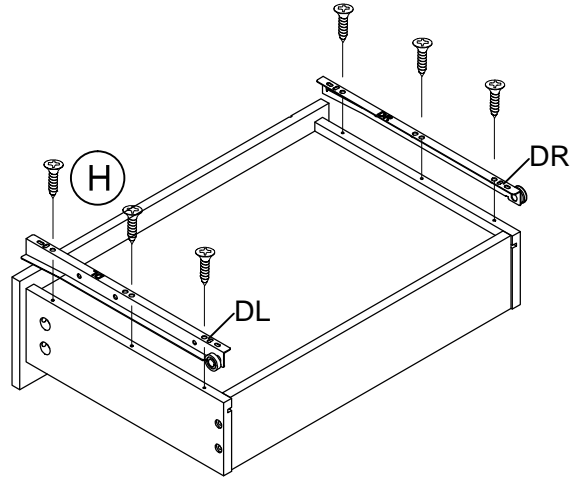
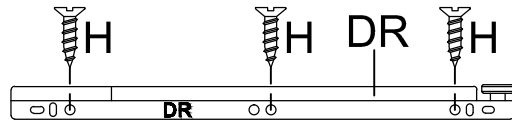
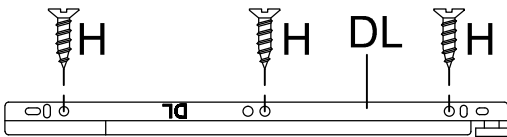
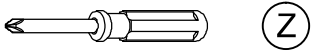
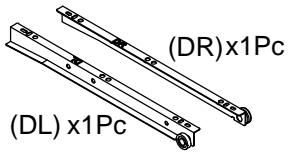

Step 40.

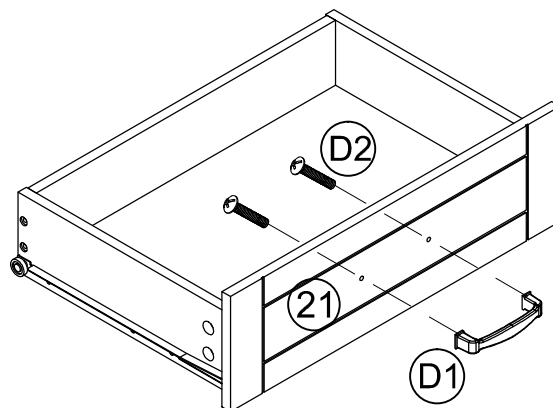
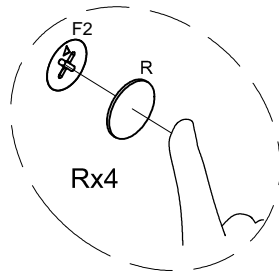
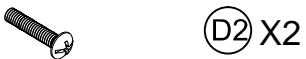

Step 41.

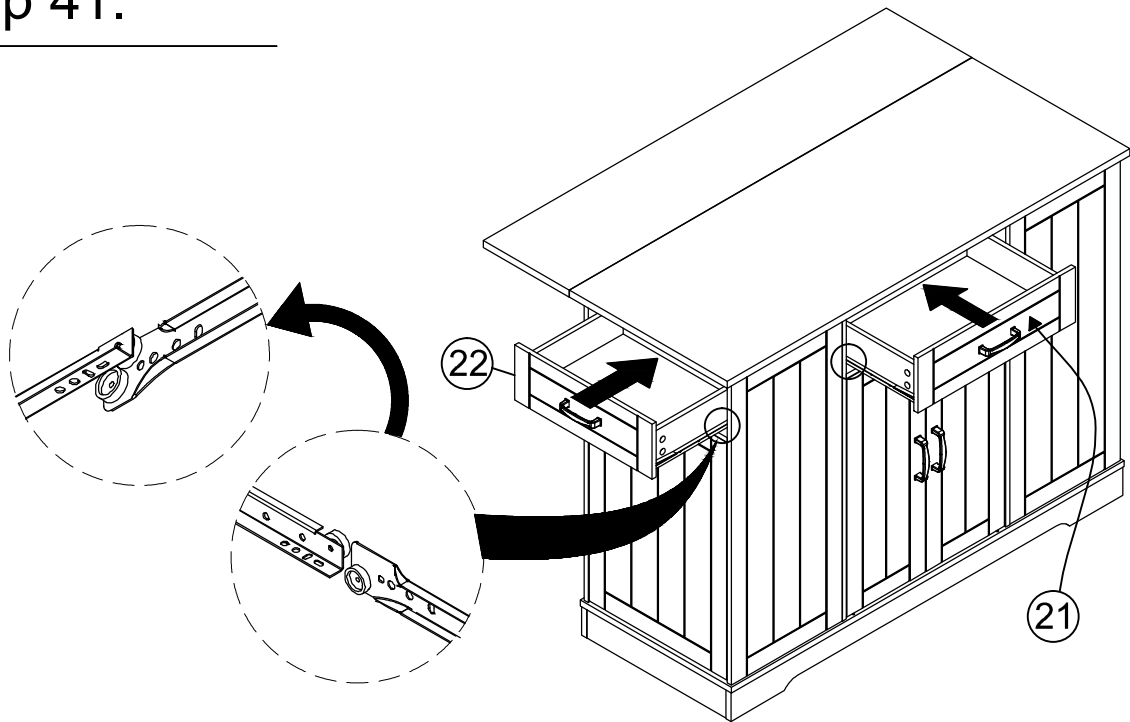

Step 42.

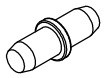

Q x4

Adjustable for three heights.
The shelf can be adjusted up
and down with three heights.

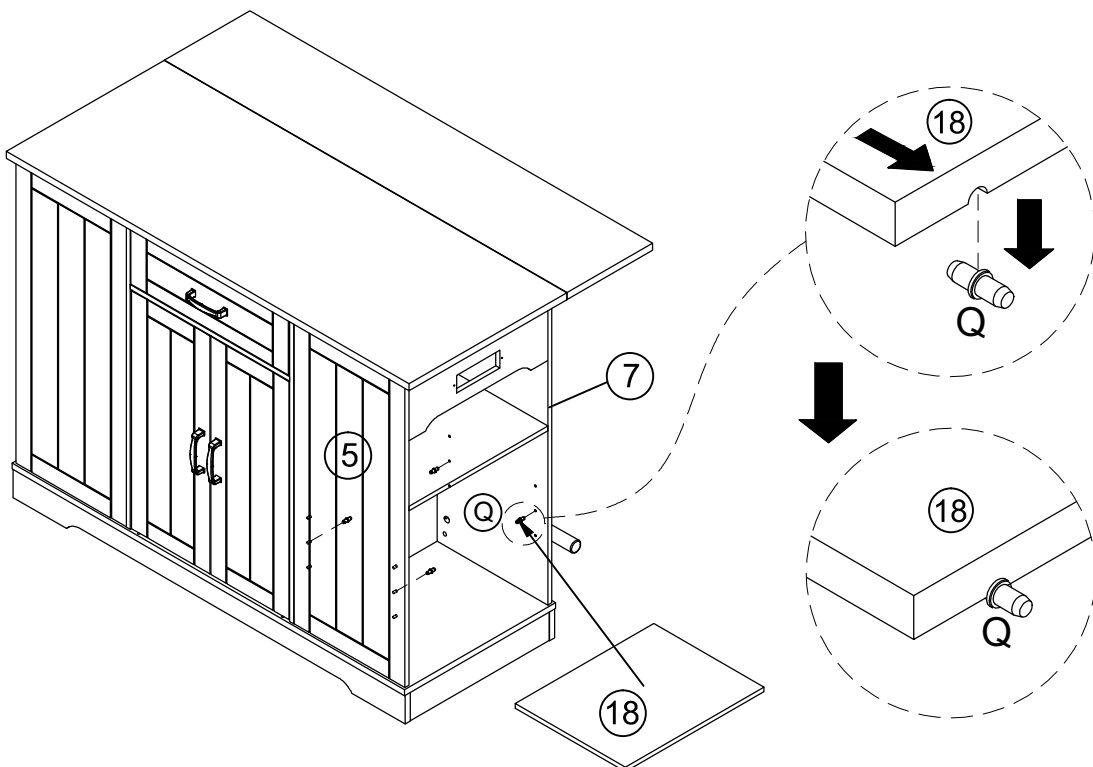

Step 43.

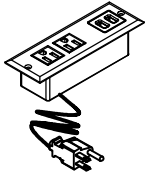

(N1) X1



(N2) X2

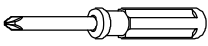

(Z)

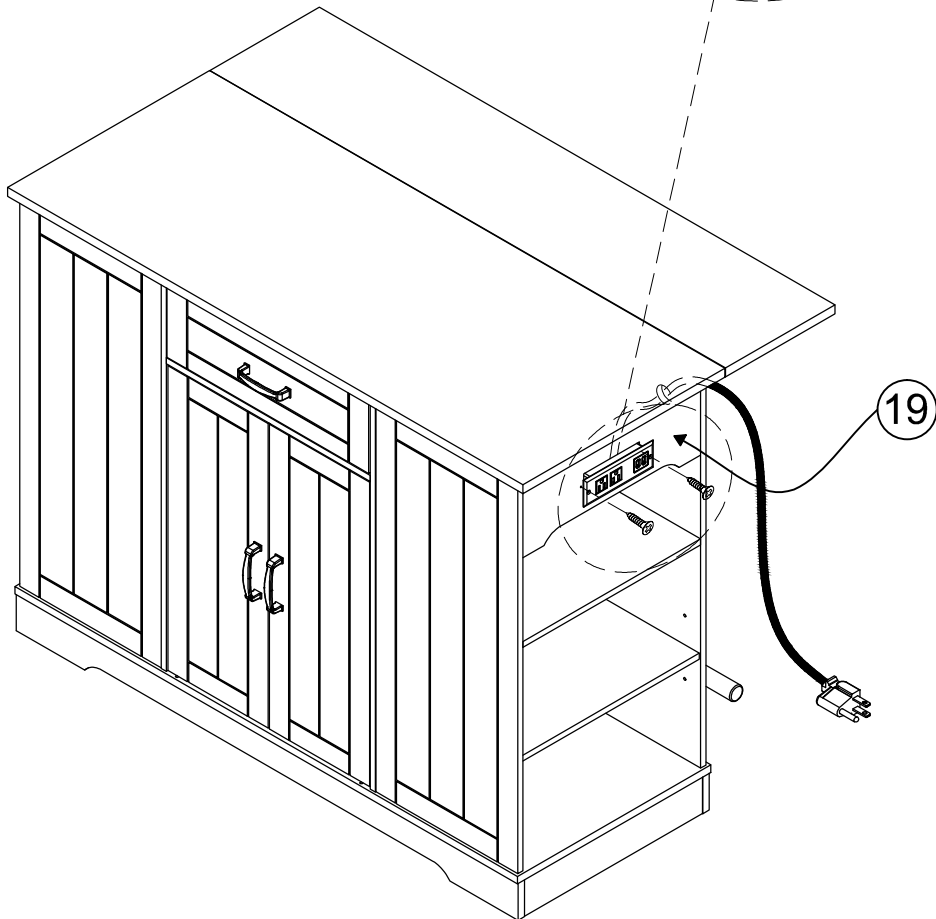
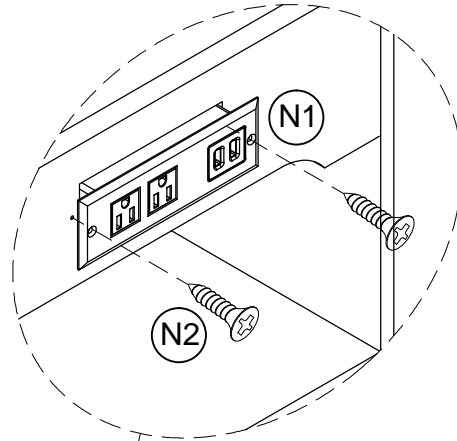

Step 44.



L1 X8



L2 X8

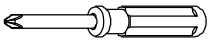

Z

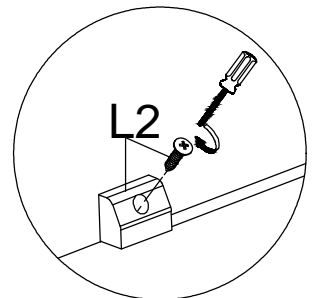
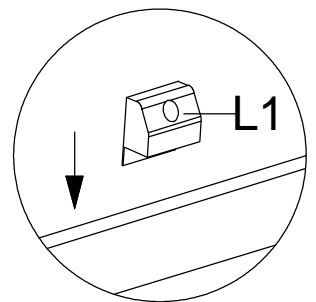
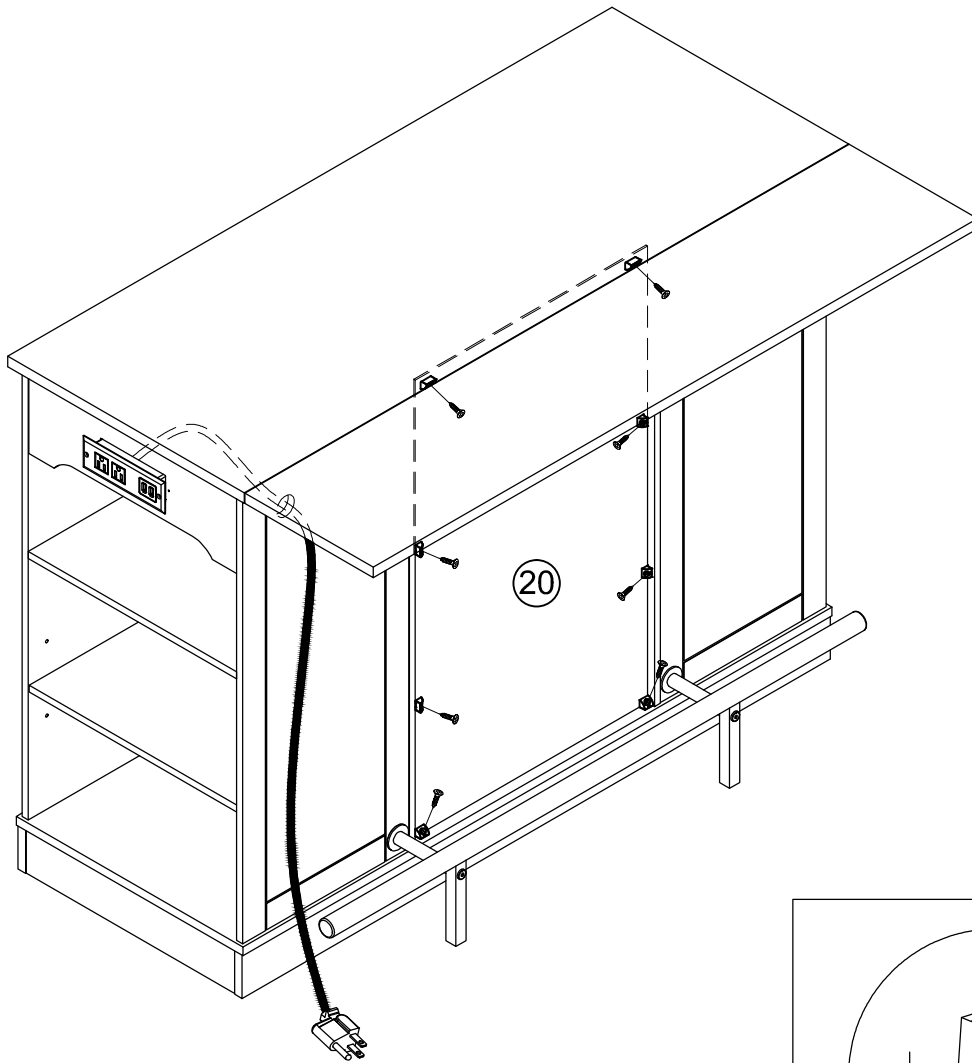

Step 45.



(A) X1



(W) X8

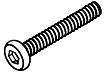

(ZD) X16

