

# CANOPY FULL / QUEEN / KING BED

## ASSEMBLY INSTRUCTIONS

**IMPORTANT NOTE! DUE TO THE SIZE OF THE BED WE RECOMMEND THE FOLLOWING TIPS TO ASSEMBLING YOUR BED.**

- 1. HELP FROM A SECOND PERSON IS REQUIRED TO INSURE A SAFE ASSEMBLY PROCESS.**
- 2. WHEN STEP 1 AND STEP 2 ARE COMPLETED LEAN THE ASSEMBLIES AGAINST A WALL TO CLEAR THE SPACE OF PARTS.**
- 3. ASSEMBLE THE BED, STEP 3 AND FORWARD IN THE FINAL SPOT YOU WANT THE BED. MOVING THE BED AFTER ASSEMBLY COULD BE DANGEROUS.**

**BOX #1**

- A. UPPER HEADBOARD SUPPORT
- B. LOWER HEADBOARD SUPPORT
- C. HEADBOARD PANEL
- D. UPPER FOOTBOARD SUPPORT
- E. FOOTBOARD PANEL
- F. SLAT ROLL

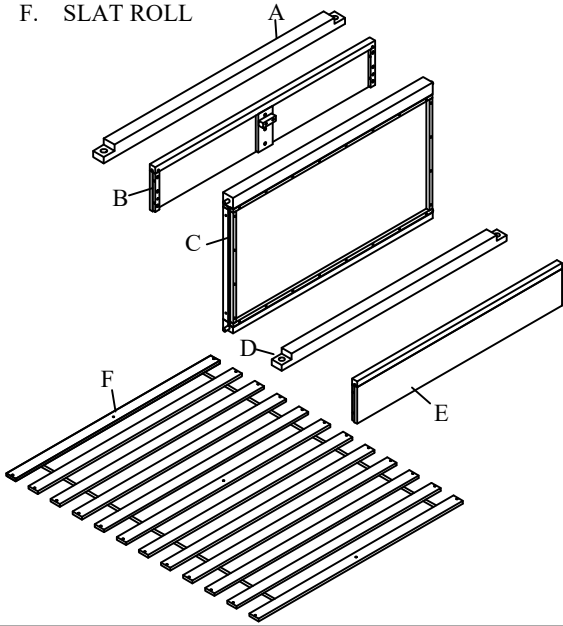

**BOX #3.**

- I. SIDE RAIL
- J. CENTER SLAT SUPPORT
- K. CENTER SLAT SUPPORT LEG
- L. CANOPY RAIL

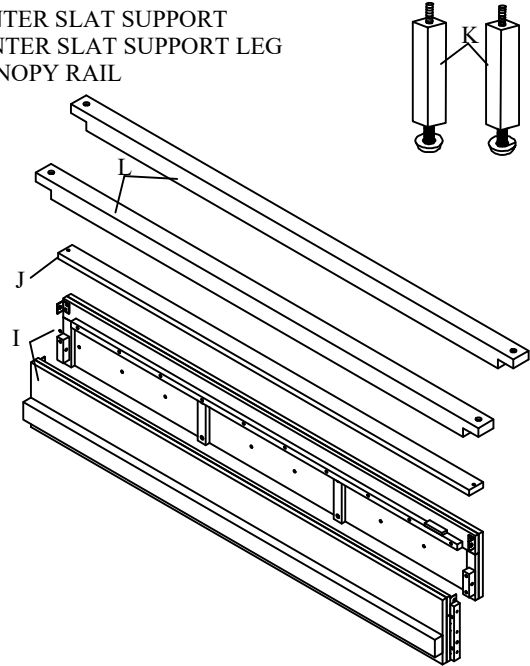

**HARDWARE PACKED IN BOX #3**

**BOX #2**

- G1. LEFT VERTICAL HEADBOARD POST
- G2. RIGHT VERTICAL HEADBOARD POST
- H1. LEFT VERTICAL FOOTBOARD POST
- H2. RIGHT VERTICAL FOOTBOARD POST

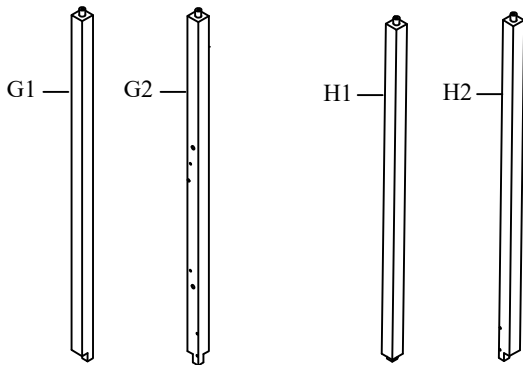

|   |                    |  |        |
|---|--------------------|--|--------|
| 1 | ALLEN BOLT (M8X50) |  | 16 PCS |
| 2 | ALLEN BOLT (M8X40) |  | 4 PCS  |
| 3 | ALLEN BOLT (M8X20) |  | 4 PCS  |
| 4 | SPRING WASHER (M8) |  | 24 PCS |
| 5 | FLAT WASHER (M8)   |  | 24 PCS |
| 6 | WOOD SCREW (M4X30) |  | 29 PCS |
| 7 | ALLEN KEY          |  | 1 PC   |

**TOOL REQUIRED**  
**PHILLIPS HEAD SCREW DRIVER AND LADDER**  
**(NOT PROVIDED)**

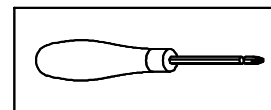

## CANOPY BED FULLY ASSEMBLED

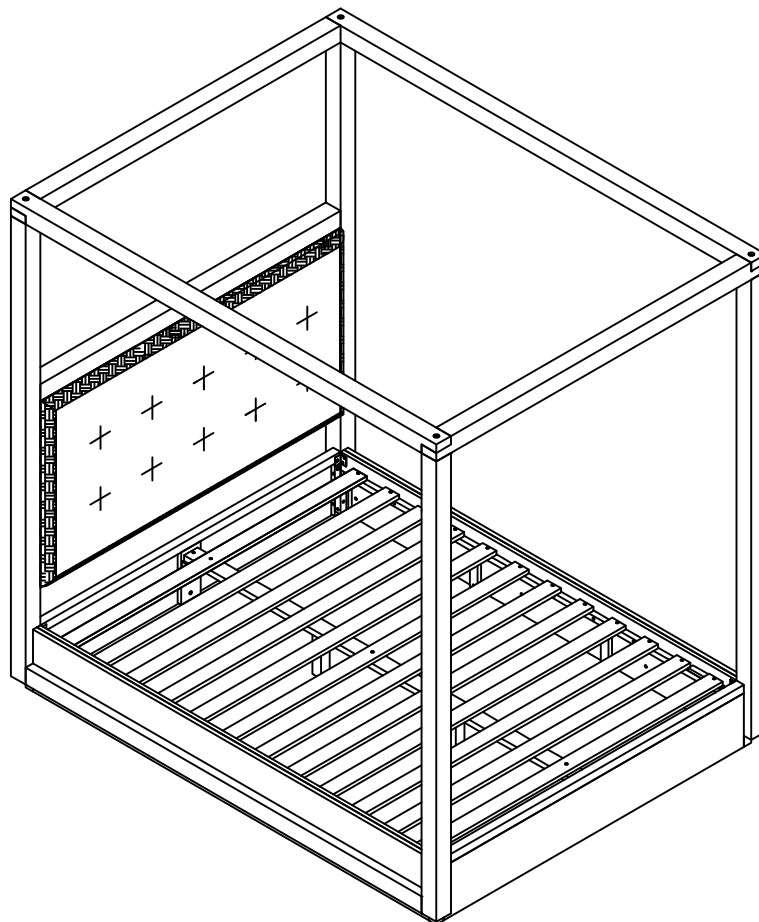

### **STEP 1:**

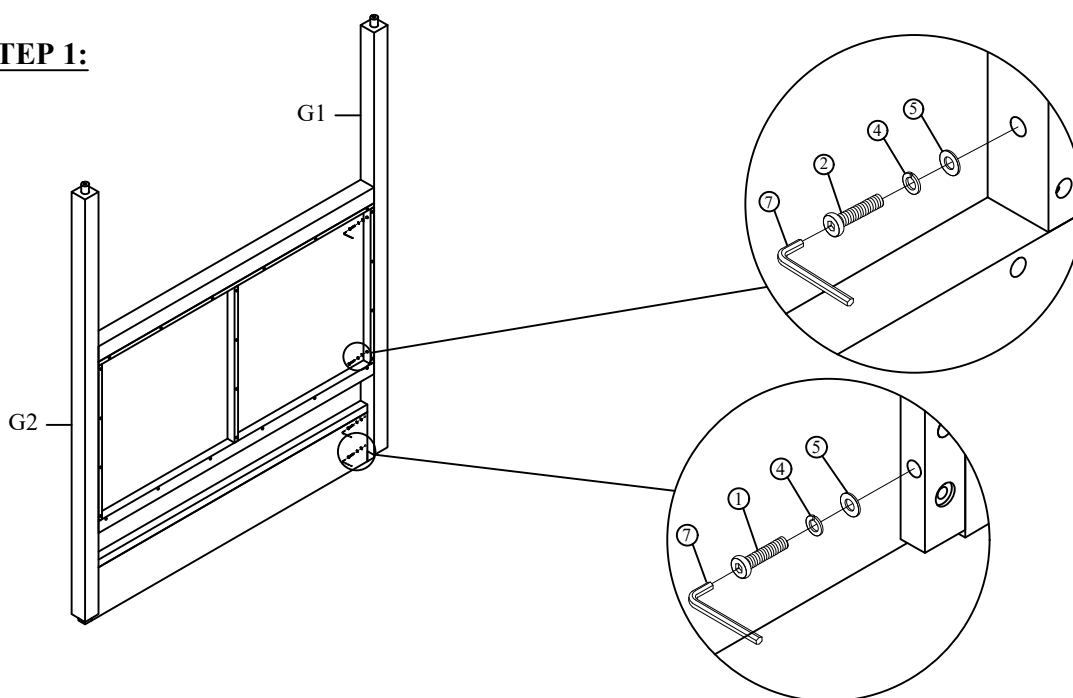

**STEP 1:** CONNECT THE HEADBOARD PANEL (C) TO THE LEFT (G1) AND RIGHT VERTICAL HEADBOARD POST (G2) WITH FOUR M8X40 ALLEN BOLTS (2), SPRING WASHERS (4) AND FLAT WASHERS (5). ONLY FINGER TIGHTEN THE BOLTS!  
ATTACH THE LOWER HEADBOARD SUPPORT (B) TO THE HEADBOARD ASSEMBLY USING FOUR M8X50 ALLEN BOLTS (1), SPRING WASHERS AND FLAT WASHERS. TIGHTEN ALL BOLTS, INCLUDING THE PREVIOUS FOUR, COMPLETELY WITH THE PROVIDED ALLEN KEY (7)

**STEP 2:**

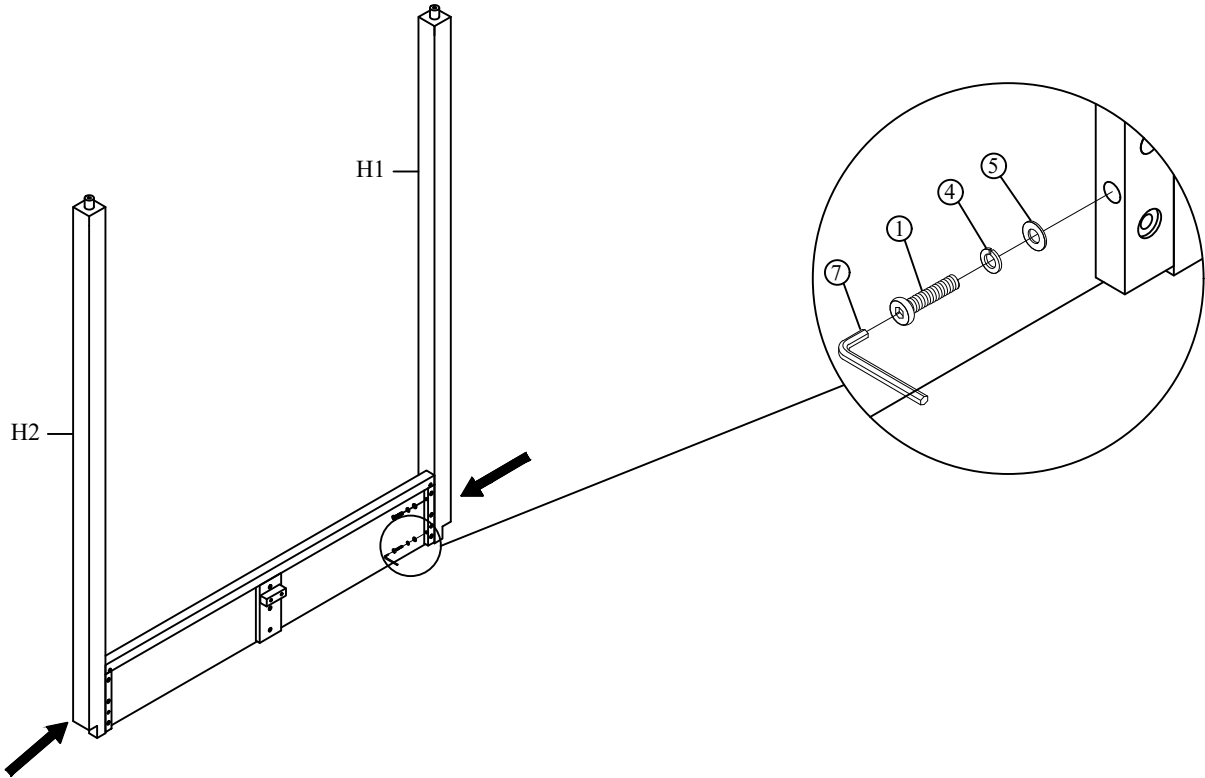

**STEP 2: CONNECT THE FOOTBOARD PANEL (3) TO THE LEFT (H1) AND RIGHT VERTICAL FOOTBOARD POSTS (H2) WITH FOUR M8X50 ALLEN BOLTS, SPRING WASHERS AND FLAT WASHERS. TIGHTEN COMPLETELY WITH THE ALLEN KEY.**

**STEP 3:**

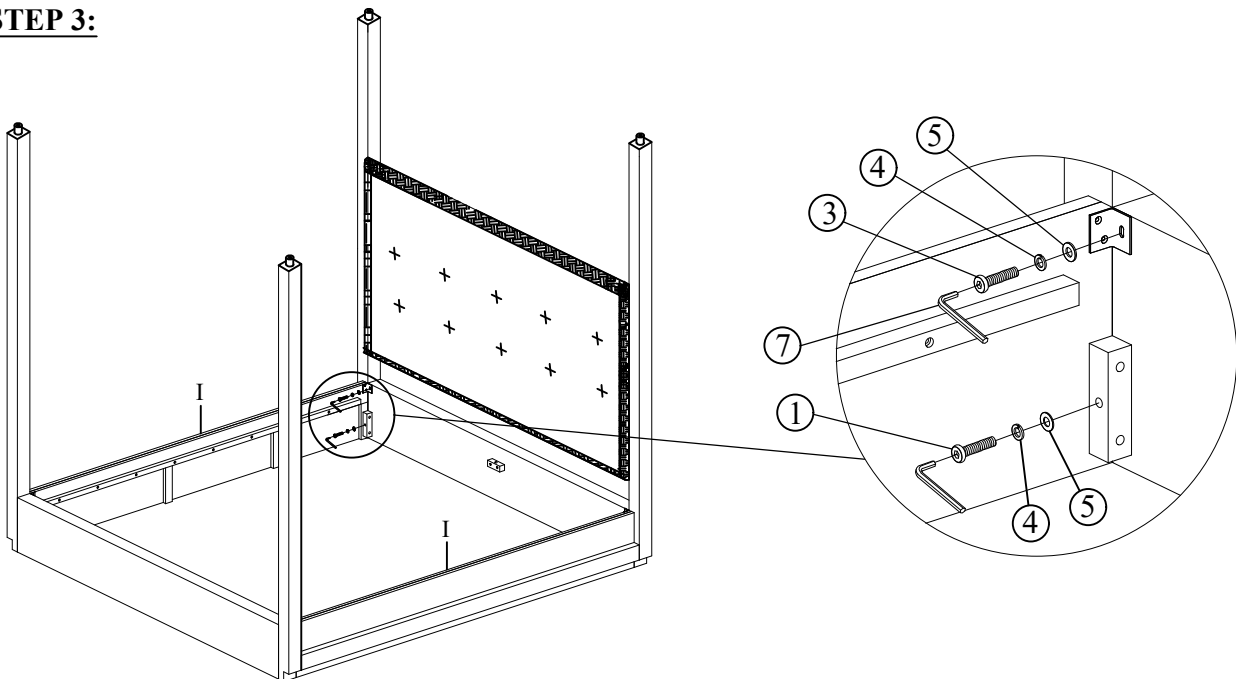

**STEP 3: WITH THE HELP OF A SECOND PERSON, CONNECT THE HEADBOARD (STEP 1) AND FOOTBOARD (STEP 2) ASSEMBLIES TO THE SIDE RAILS (I). FOLLOWING THE ILLUSTRATION, CONNECT THE TOP SIDE RAIL BRACKET WITH ONE M8X20 ALLEN BOLT (3), SPRING WASHER AND FLAT WASHER. CONNECT THE BOTTOM SIDE RAIL BRACKET WITH ONE M8X50 ALLEN BOLT, SPRING WASHER AND FLAT WASHER. DO NOT TIGHTEN COMPLETELY UNTIL BOTH ENDS OF EACH SIDE RAIL HAVE BEEN ATTACHED. ONCE ALL PIECES ARE CONNECTED, TIGHTEN ALL BOLTS WITH THE ALLEN KEY.**

**STEP 4:**

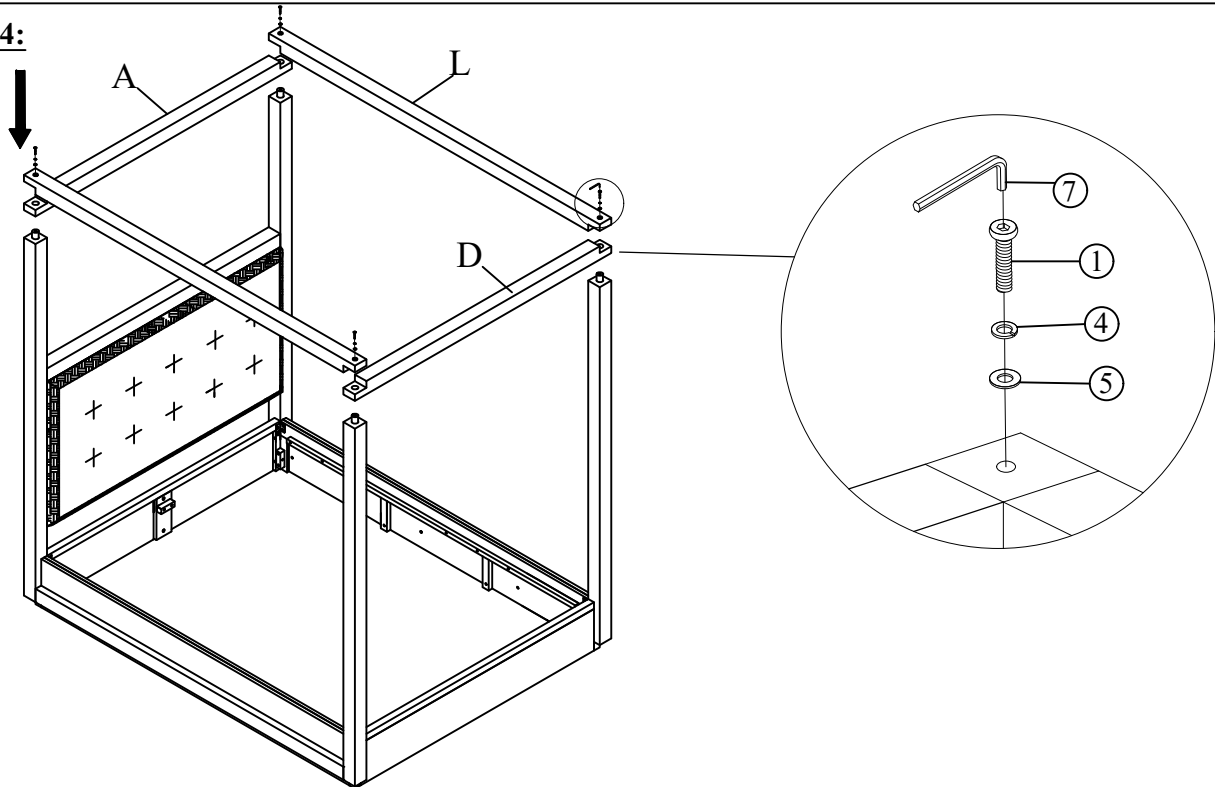

**STEP 4:** WITH THE USE OF A STEP LADDER (NOT INCLUDED) AND FOLLOWING THE ILLUSTRATION, CONNECT THE UPPER HEADBOARD SUPPORT (A) AND UPPER FOOTBOARD SUPPORT (D) THEN THE CANOPY RAILS (L) TO THE VERTICAL HEADBOARD AND FOOTBOARD POSTS. ONCE SUPPORTS AND RAILS ARE IN PLACE, SECURE THE COMPONENTS WITH FOUR M8X50 ALLEN BOLTS, SPRING WASHERS AND FLAT WASHERS. TIGHTEN ALL BOLTS WITH THE ALLEN KEY.

**STEP 5:**

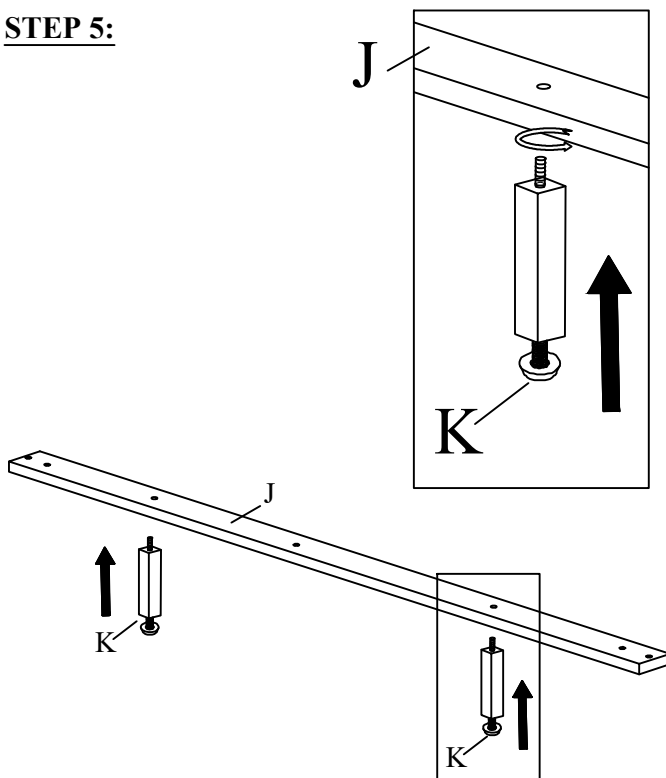

**STEP 5:** ATTACH THE CENTER SLAT SUPPORT LEGS (K) TO THE CENTER SLAT SUPPORT (J).

**STEP 6:**

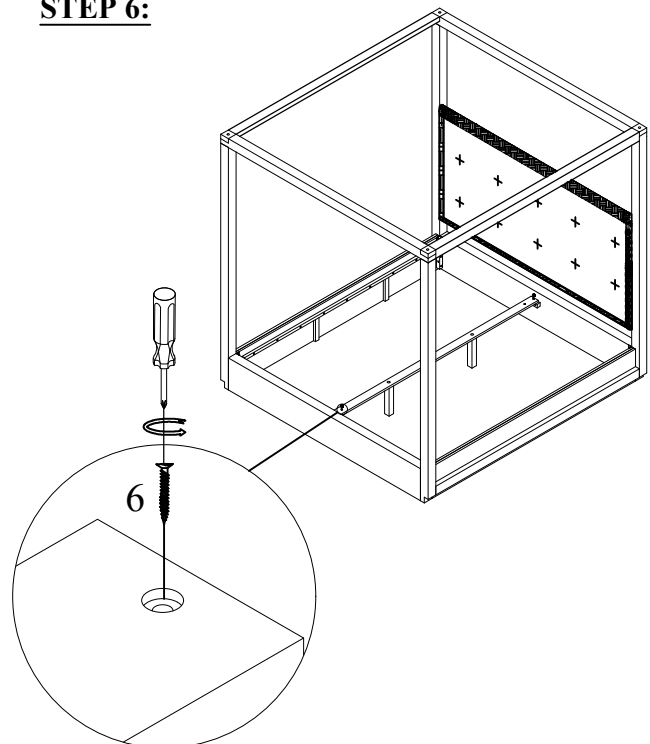

**STEP 6:** CONNECT THE CENTER SLAT SUPPORT ASSEMBLY (STEP 5) TO THE SLAT CLEAT ATTACHMENT ON THE HEAD AND FOOTBOARD, AS SHOWN IN THE ILLUSTRATION. SECURE THE SLAT SUPPORT TO THE BED USING TWO WOOD SCREWS (6).

**STEP 7:**

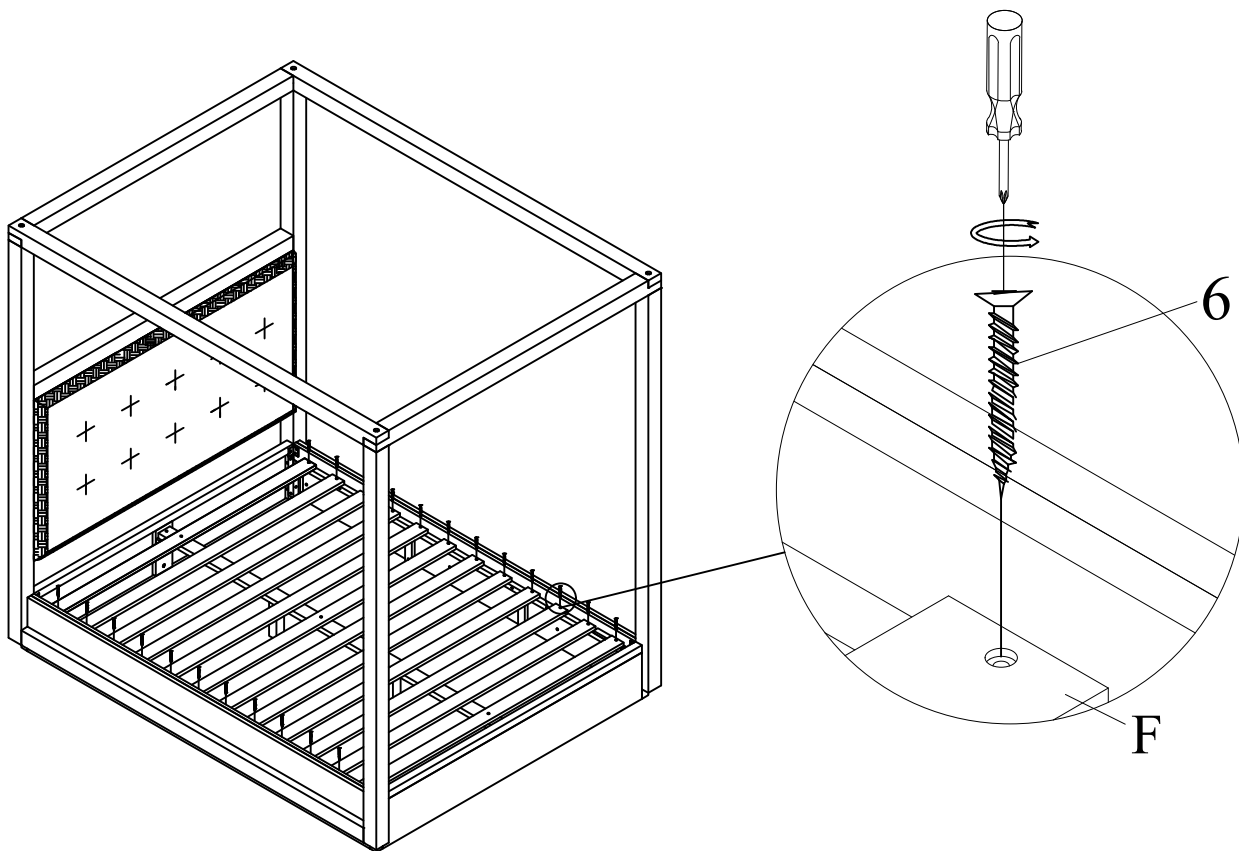

**STEP 7: ATTACH THE SLAT ROLL (F) TO THE BED ASSEMBLY AS SHOWN AND SECURE WITH WOOD SCREWS.**

**INSTRUCTIONS FOR ADJUSTING LEVELER**

POSITION THE BED IN YOUR SPACE AND LOCATE THE LEVELER UNDER EACH SUPPORT LEG. TURN THE LEVELER COUNTER-CLOCKWISE TO EXTEND THE LEVELER AND CLOCKWISE TO RETRACT IT.

ADJUST EACH LEVELER UNTIL EACH SUPPORT LEG IS APPLY EQUAL, UPWARD PRESSURE ON THE SUPPORT SLAT.

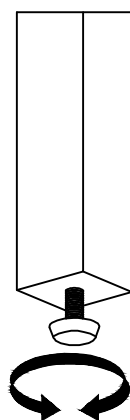

**MAINTENANCE INSTRUCTIONS:**

REMOVE YOUR MATTRESS, AND BOX SPRING IF APPLICABLE, BEFORE MOVING YOUR BED.

LIFT YOUR BED WHEN MOVING IT; DRAGGING CAN DAMAGE THE SUPPORTS.

RE-ADJUST THE LEVELERS AFTER MOVING YOUR BED.