

INSTALLATION INSTRUCTIONS

10x14 ft Storage Shed

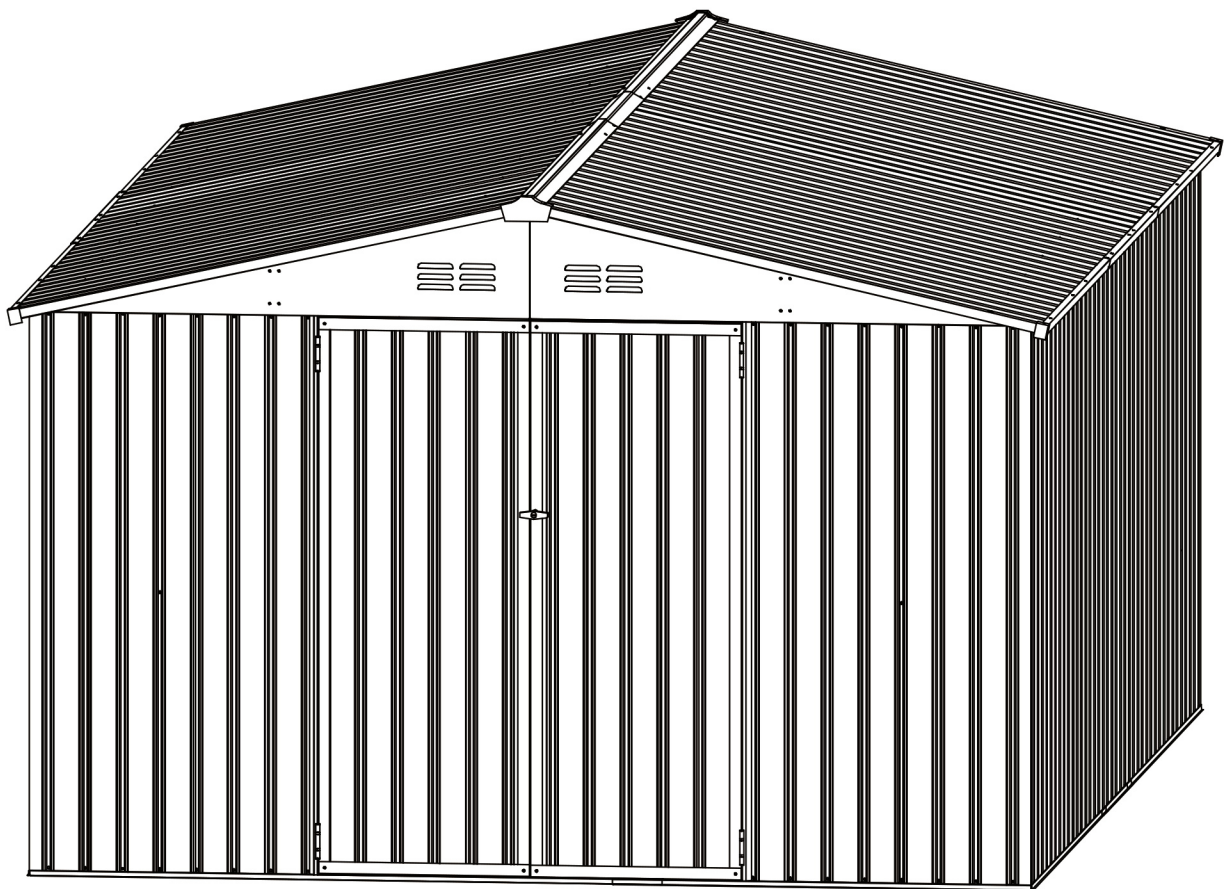





After opening the package, if you notice a slight deformation in the wall panels, there's no need for concern. Our material is flexible and can be manually bent back into place.

Recommended to wear gloves to avoid scratches.

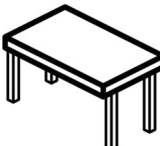
Please read the instructions **COMPLETELY** before assembly.

REQUIRED TOOLS

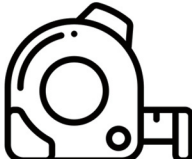
Tools			
	Gloves	Table	Ladder
			
	Power drill	Screw drive	Tape Measure

ASSEMBLY TIPS

1. Clear a working area to allow access on all four sides. A raised work surface will make assembly easier. It is easier to install the wall panel on the table.
2. All parts are identified, so when working through the instructions page by page, the diagrams show where each part is positioned.
3. Before starting, to avoid any accidental injury, we recommend the use of gloves to protect your hands.
4. Please keep children away from your construction site.
5. Most assembly can be completed by one person, but assistance may be needed when you reach the erection stage.
6. Please note: Some local government authorities have rules & regulations on shed installation, and you may need approval to erect this shed.







ASSEMBLY STEPS

1. Unpack all components from the carton and lay them out beside your work area. Check parts against the parts list.
2. Work through the assembly instructions page by page.
3. Once assembly is completed, place the shed in position and fix the anchor to the ground.
4. Clean up all metal pieces and screws.

K1014parts list(A)

PART	NO.	QTY.
	W5-KD	2
	W5-D	25

K1014parts list(B)

PART	NO.	QTY.
	K1014-7L	2
	K1014-7M	16
	K1014-7R	2
	W5-CD	4
	W3-D	2
	W2-HLD	1
	W2-HRD	1

Shed top panels

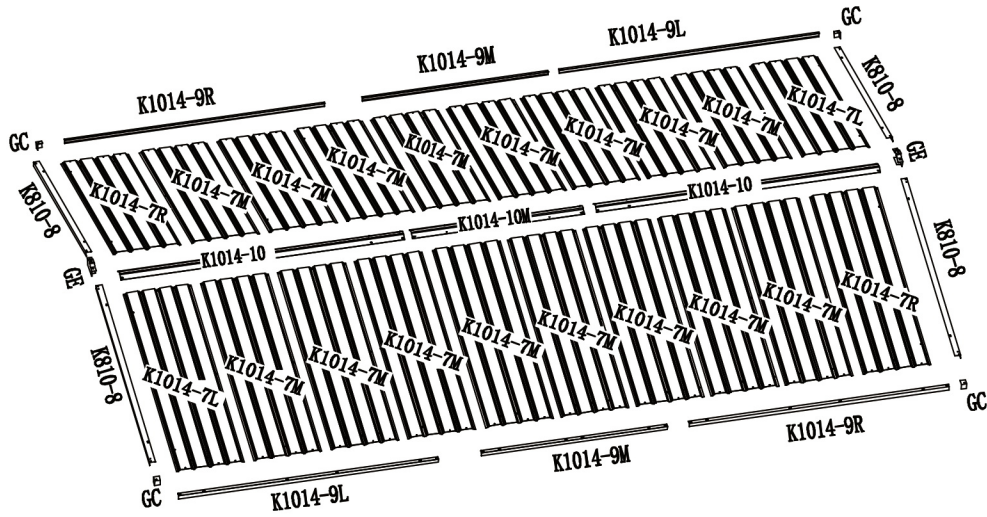



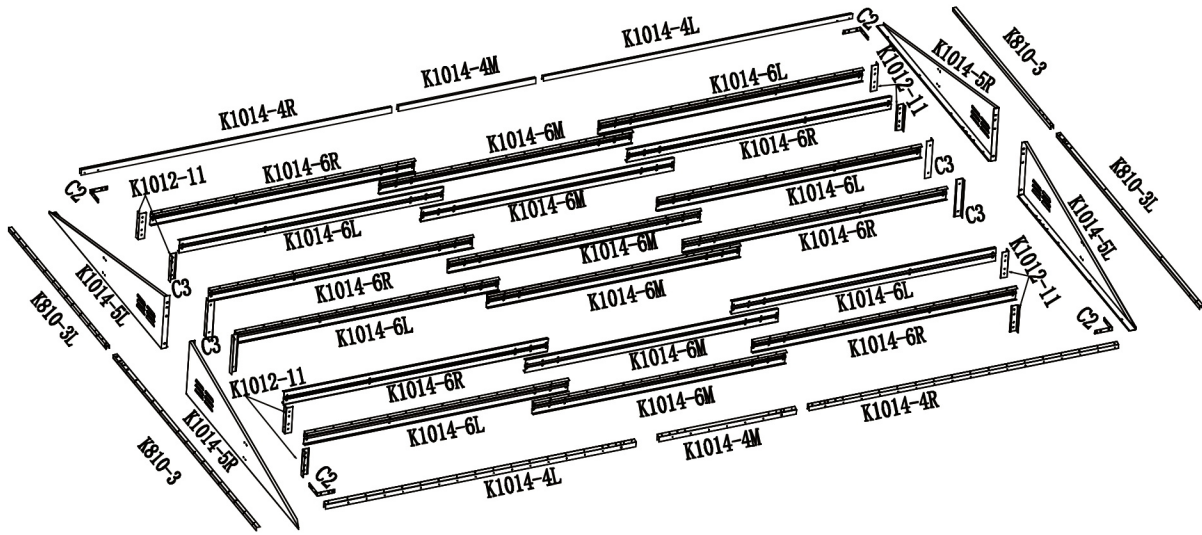

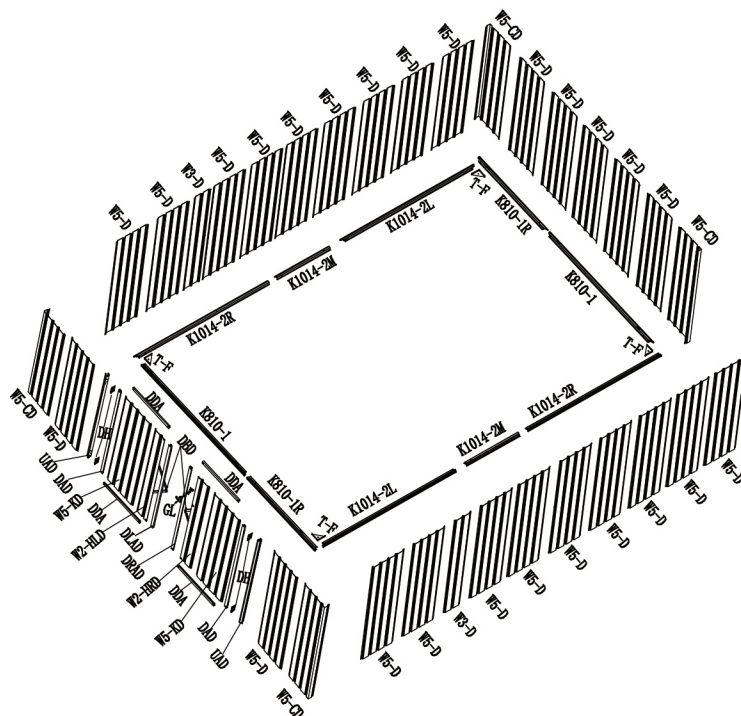

Shed top frame



Door and Shed base



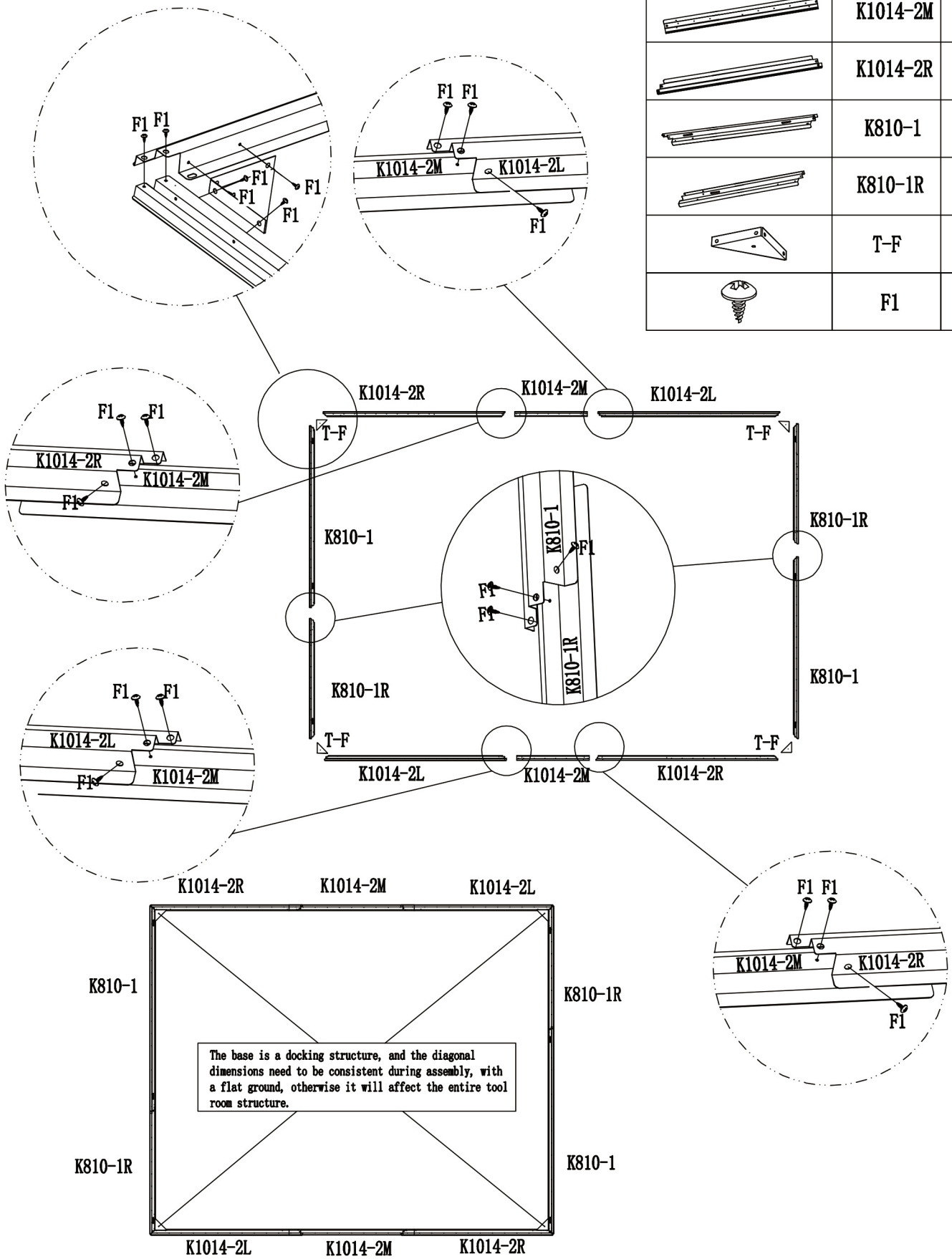

STEP 1

PART	NO.	QTY.
	K1014-2L	2
	K1014-2M	2
	K1014-2R	2
	K810-1	2
	K810-1R	2
	T-F	4
	F1	42







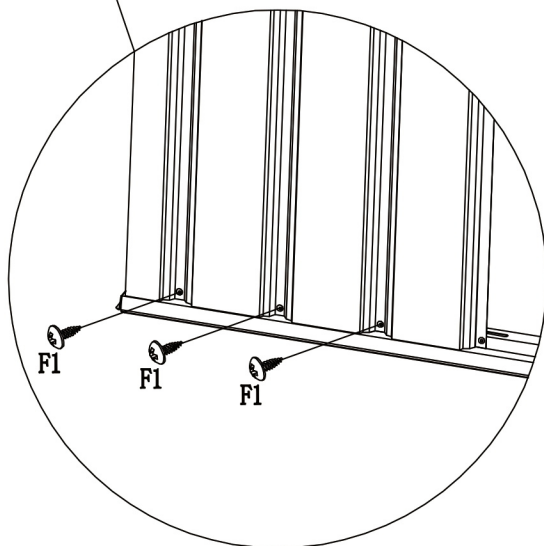
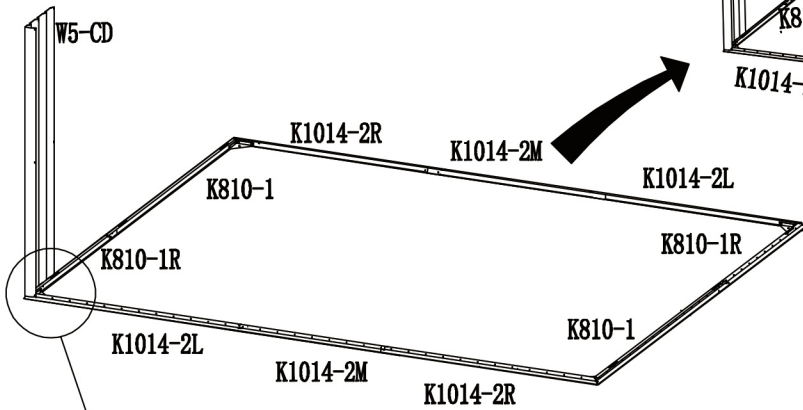
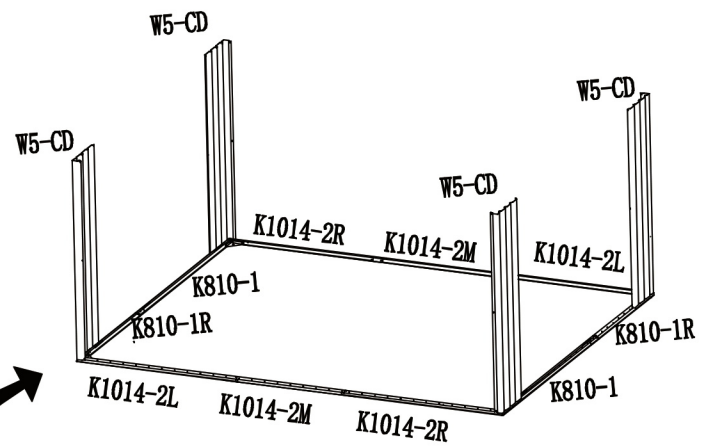
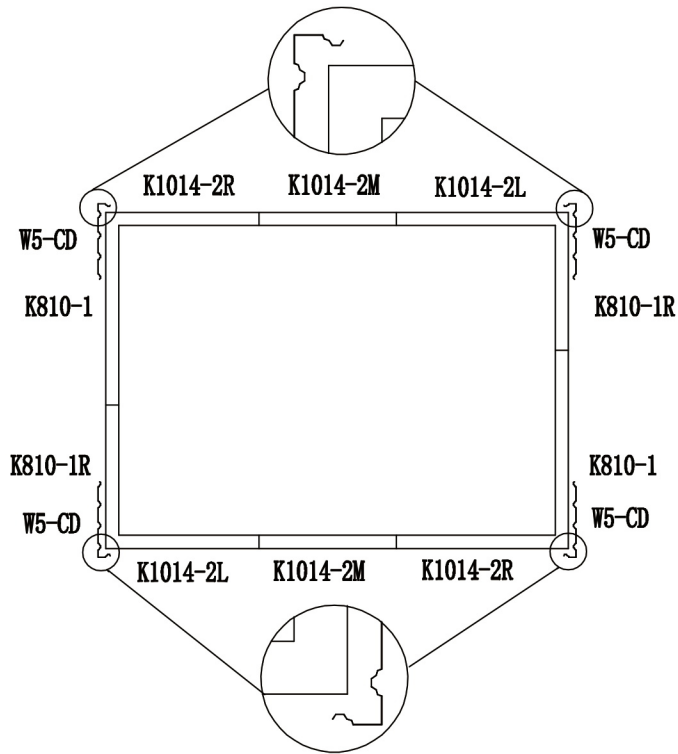

STEP 2

PART	NO.	QTY.
	W5-CD	4
	F1	12





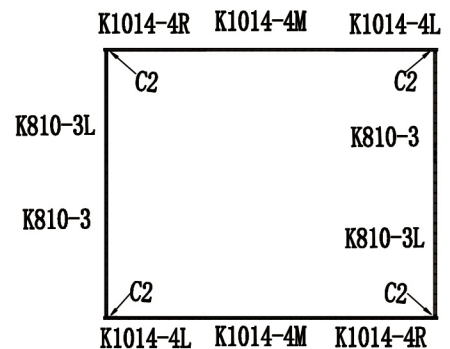
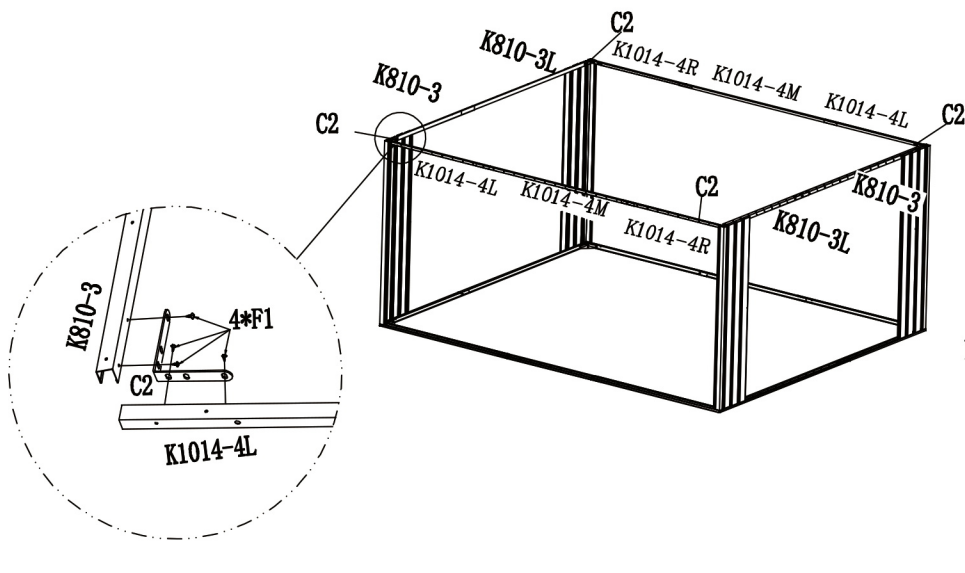
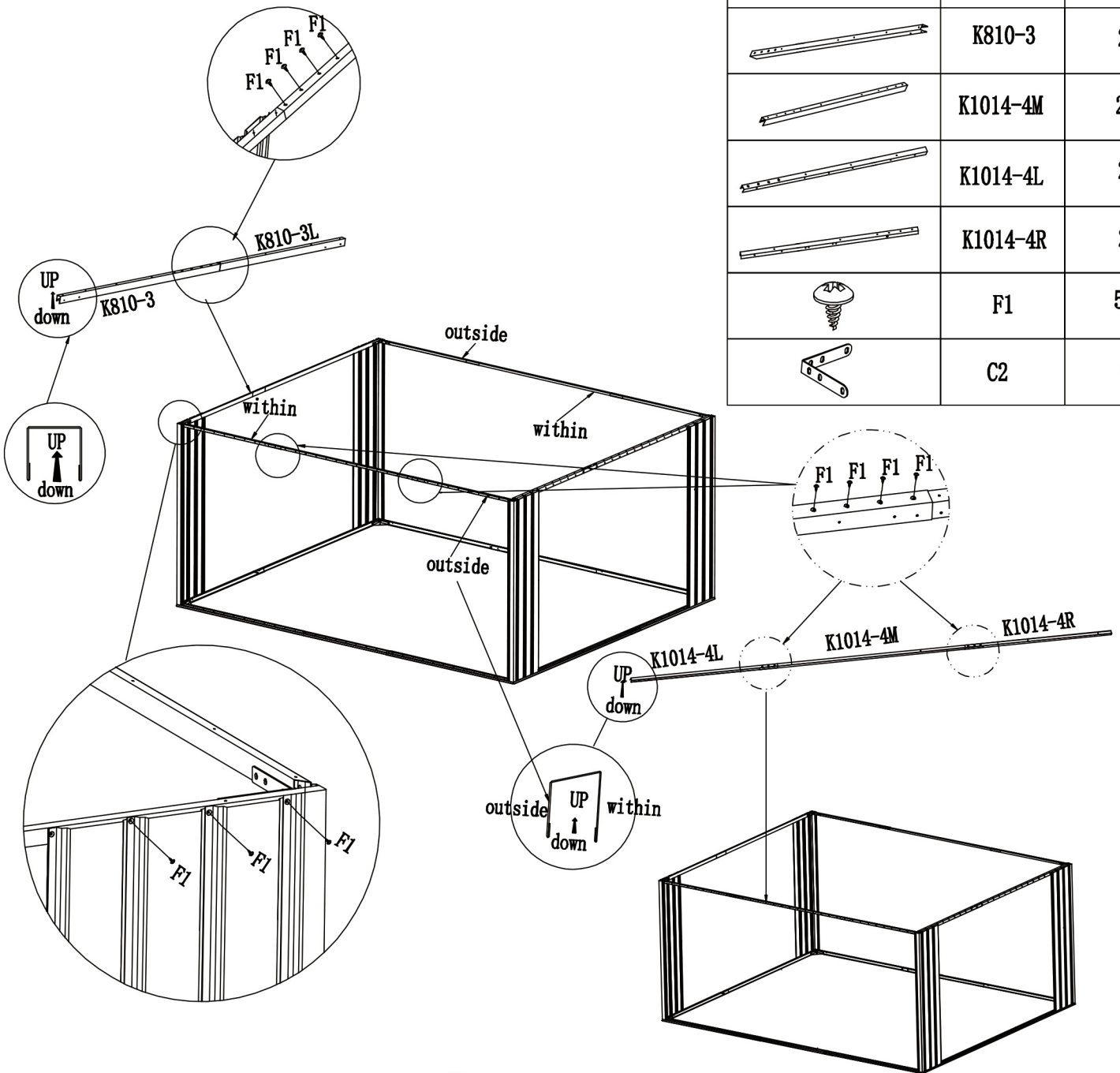

STEP 3

PART	NO.	QTY.
	K810-3L	2
	K810-3	2
	K1014-4M	2
	K1014-4L	2
	K1014-4R	2
	F1	52
	C2	4

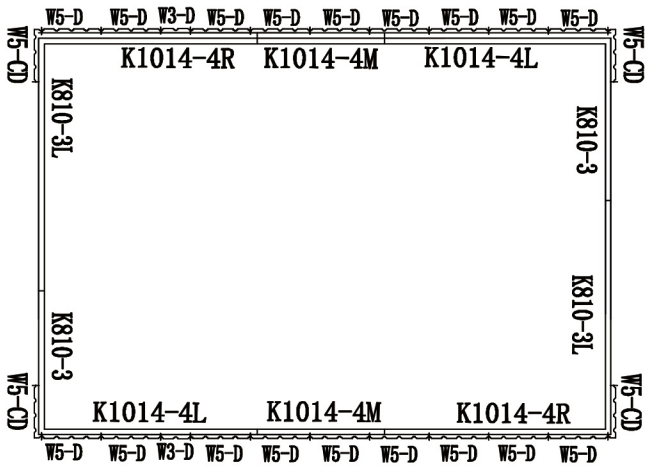

STEP 4



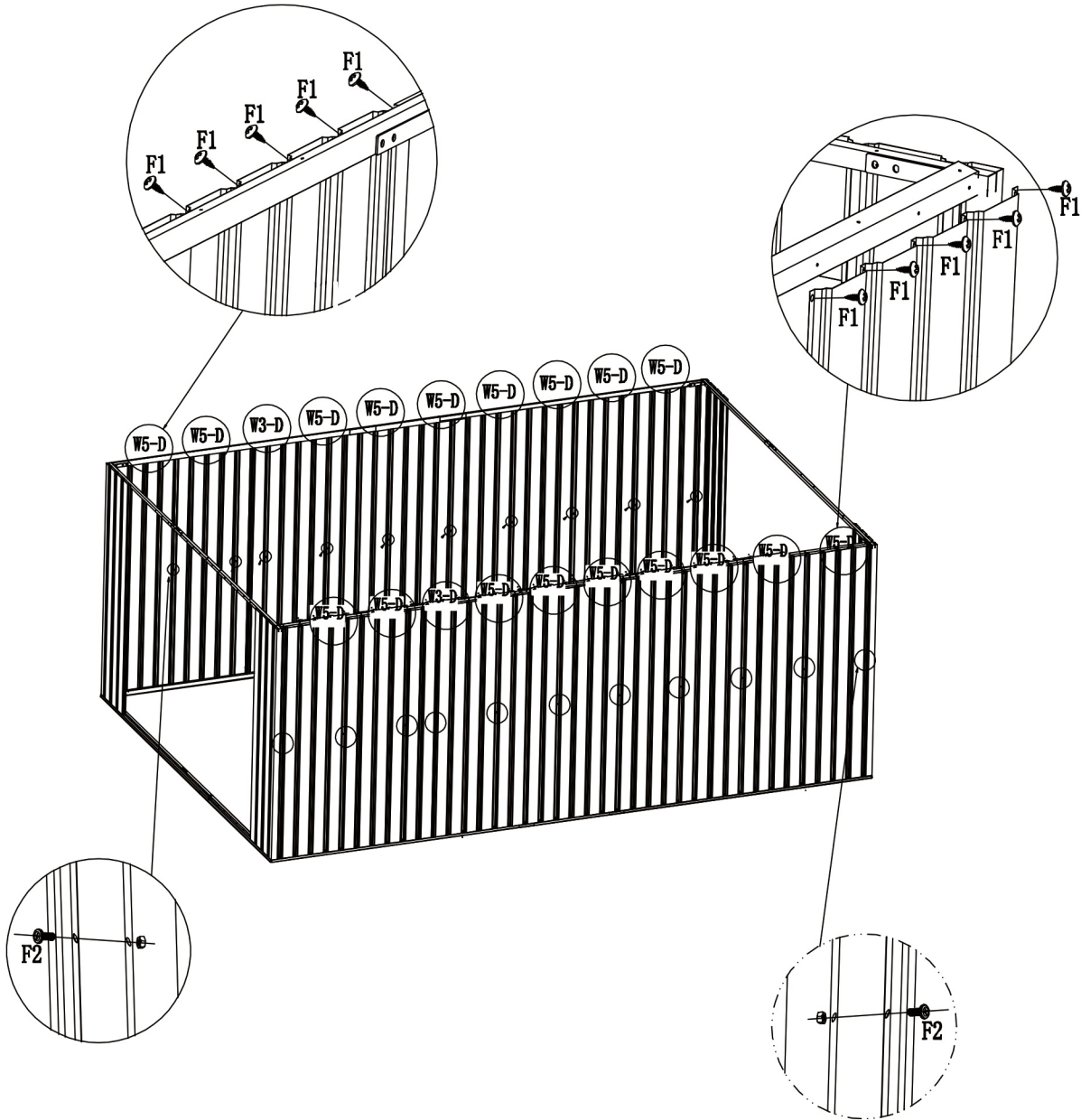

PART	NO.	QTY.
	W5-D	18
	W3-D	2
	F1	156
	F2	22

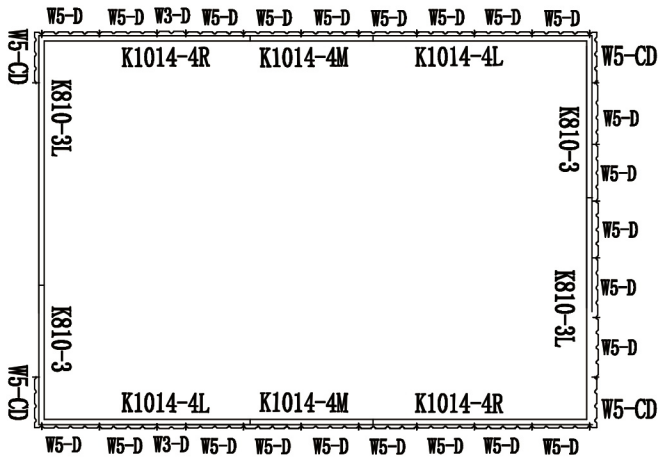

STEP 5



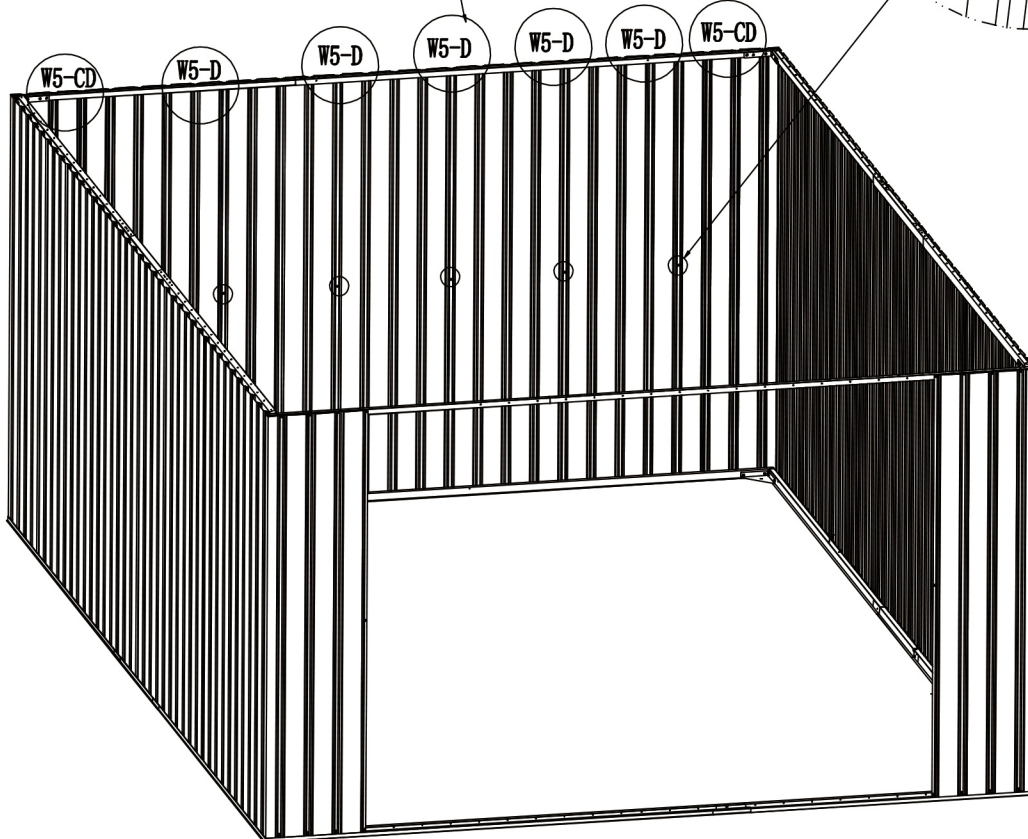
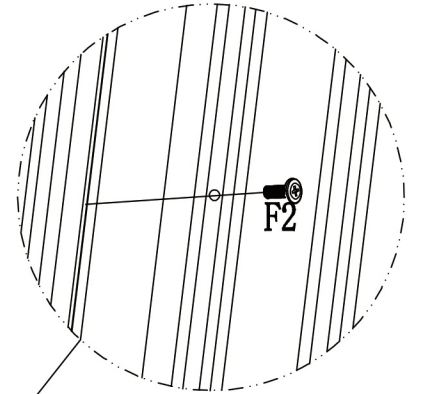
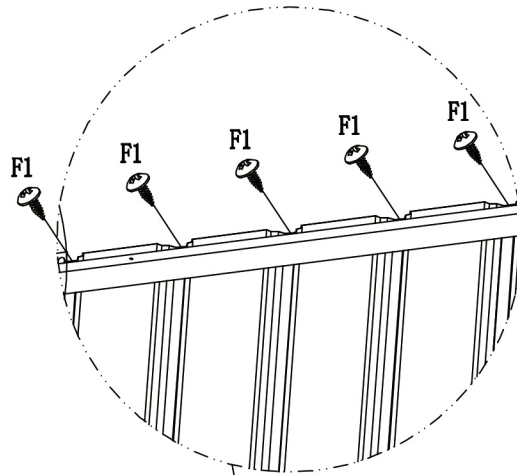

PART	NO.	QTY.
	W5-D	5
	F1	42
	F2	6

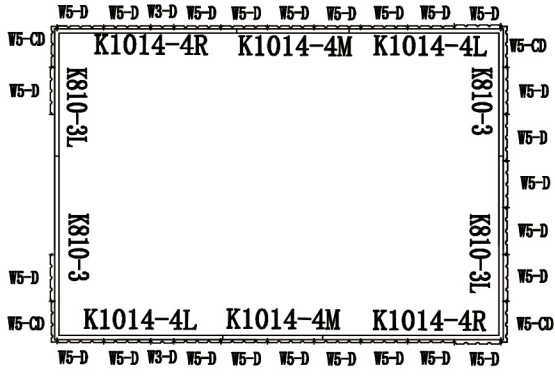

STEP 6



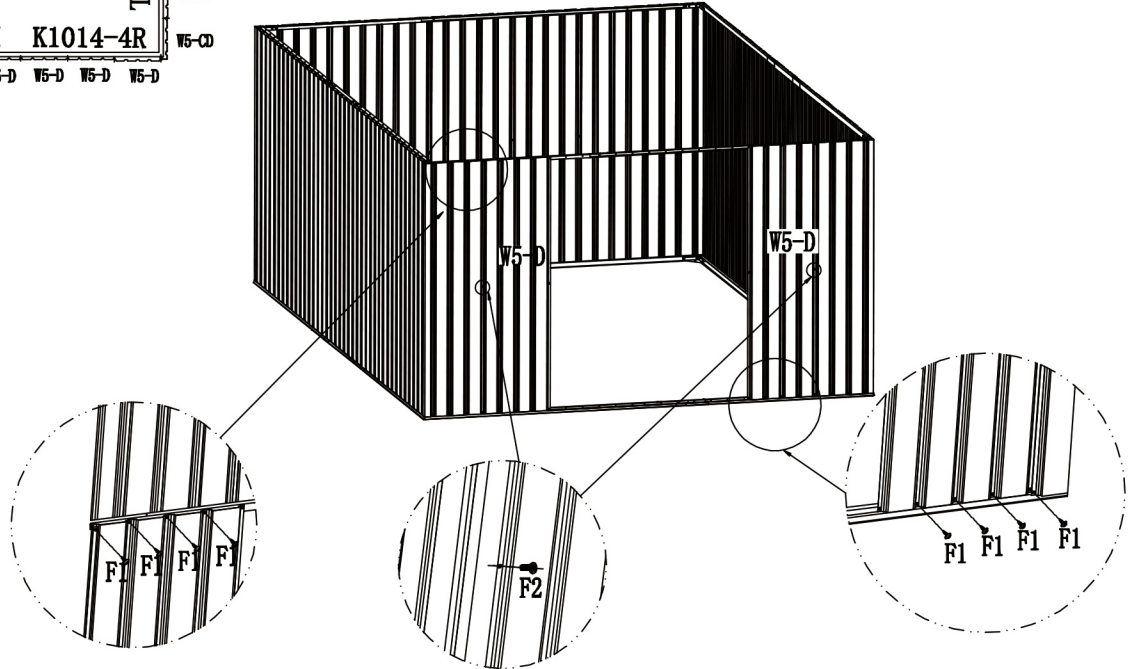

PART	NO.	QTY.
	W5-D	2
	F1	16
	F2	2



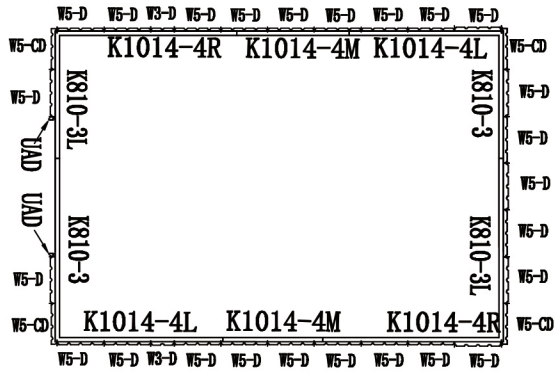

STEP 7

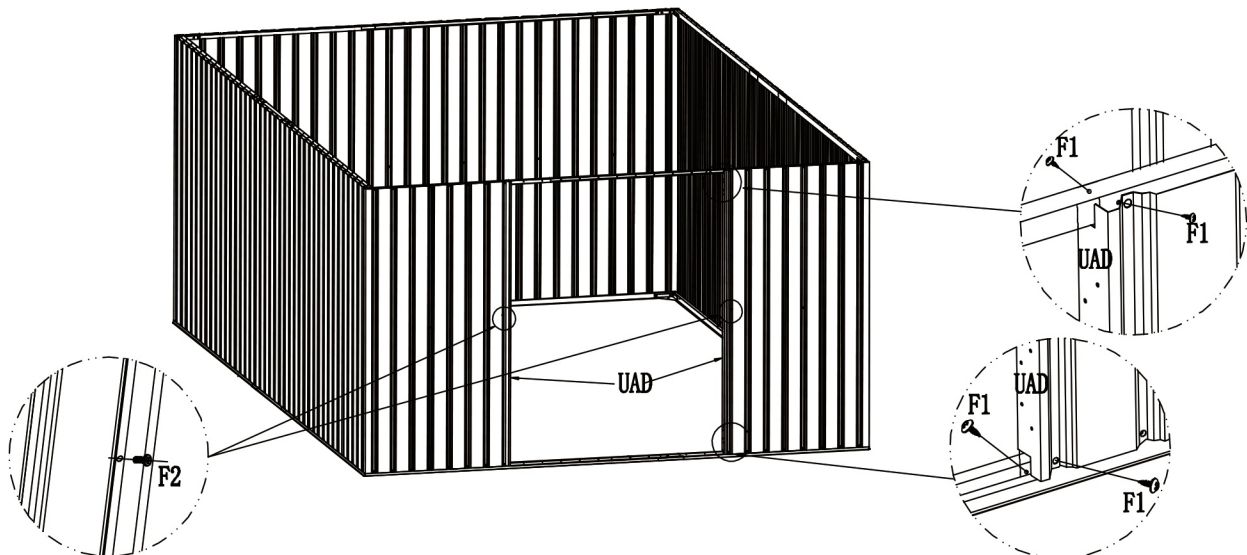

PART	NO.	QTY.
	UAD	2
	F1	8
	F2	2



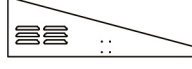

STEP 8

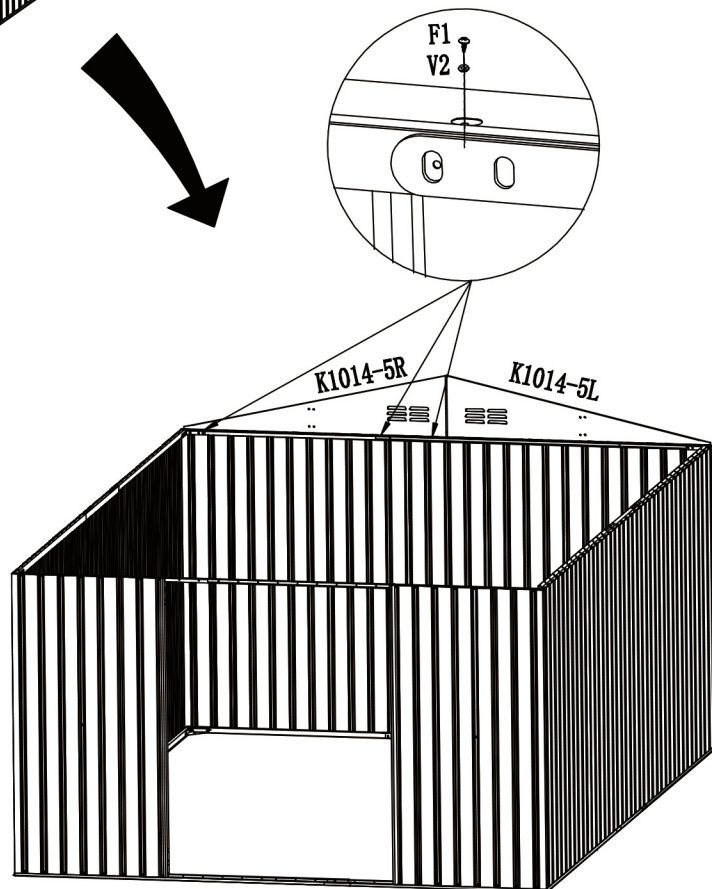
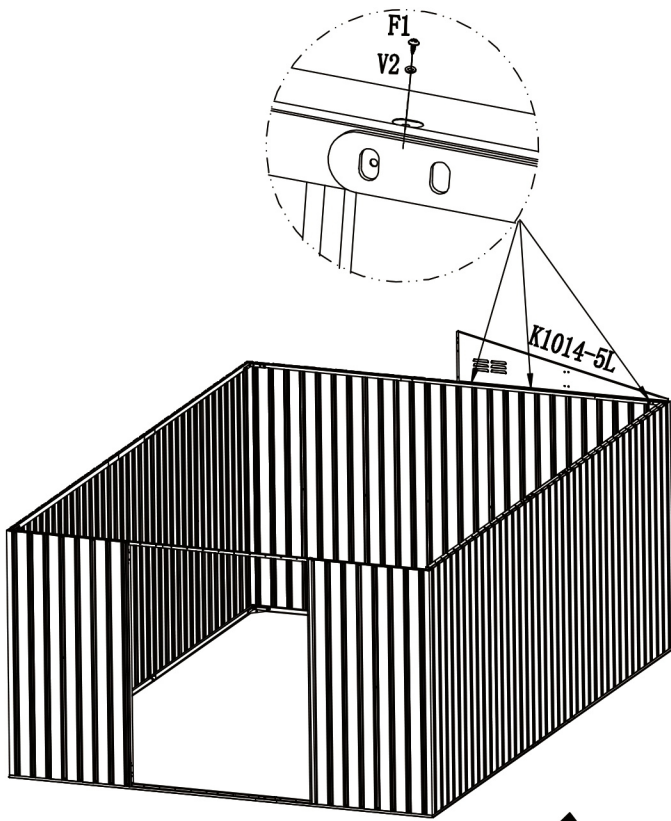
PART	NO.	QTY.
	K1014-5L	1
	K1014-5R	1
	F1	8
	V2	8



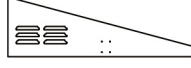

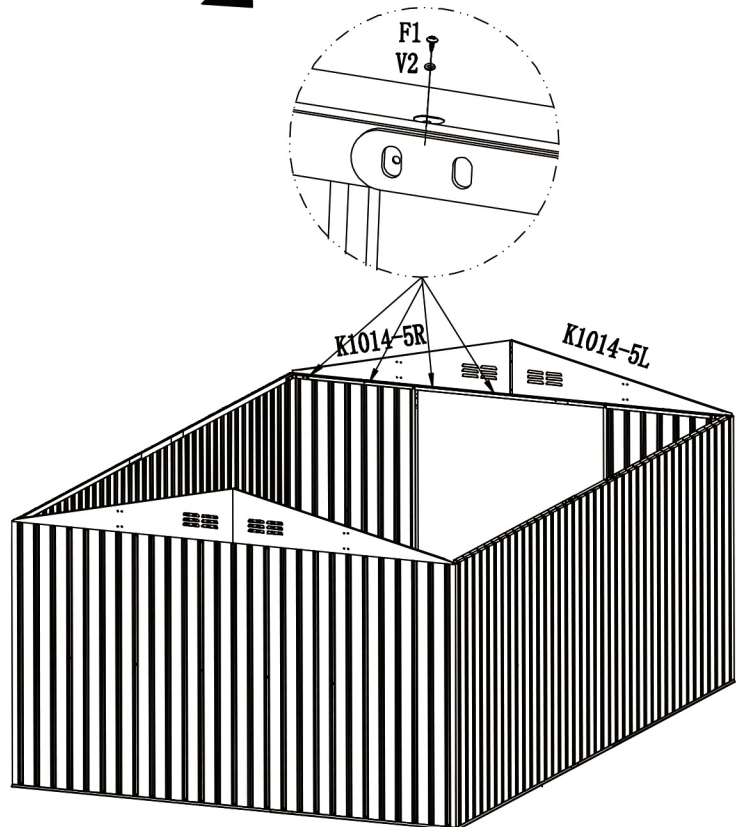
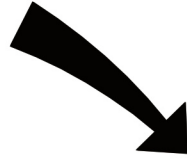
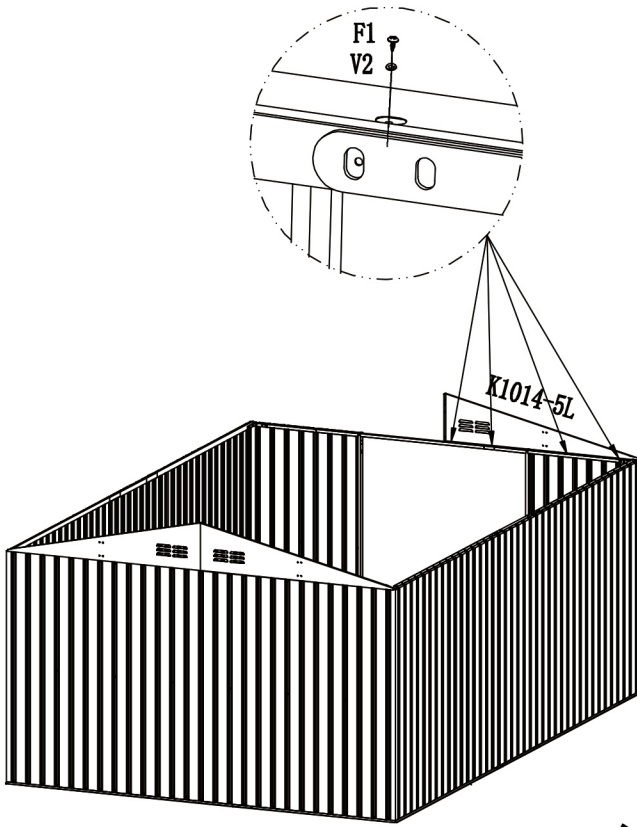

STEP 9

PART	NO.	QTY.
	K1014-5L	1
	K1014-5R	1
	F1	8
	V2	8

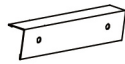



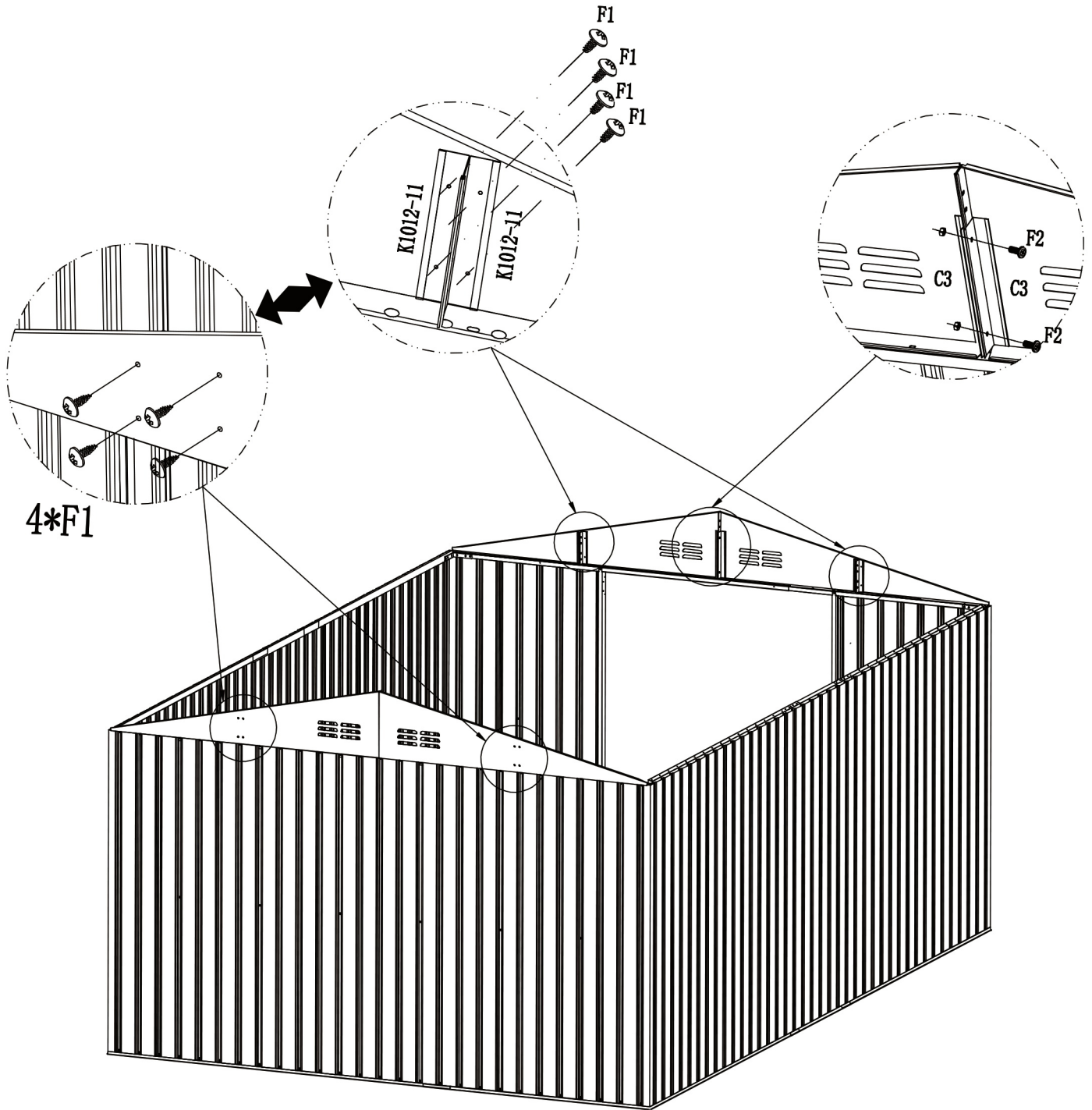

STEP 10

PART	NO.	QTY.
	C3	4
	K1012-11	8
	F2	4
	F1	16



STEP 11

The K1014-6M is small enough in width to snap into the K1014-6L and K1014-6R and align their holes

PART	NO.	QTY.
	K1014-6L	6
	K1014-6R	6
	K1014-6M	6
	F2	48

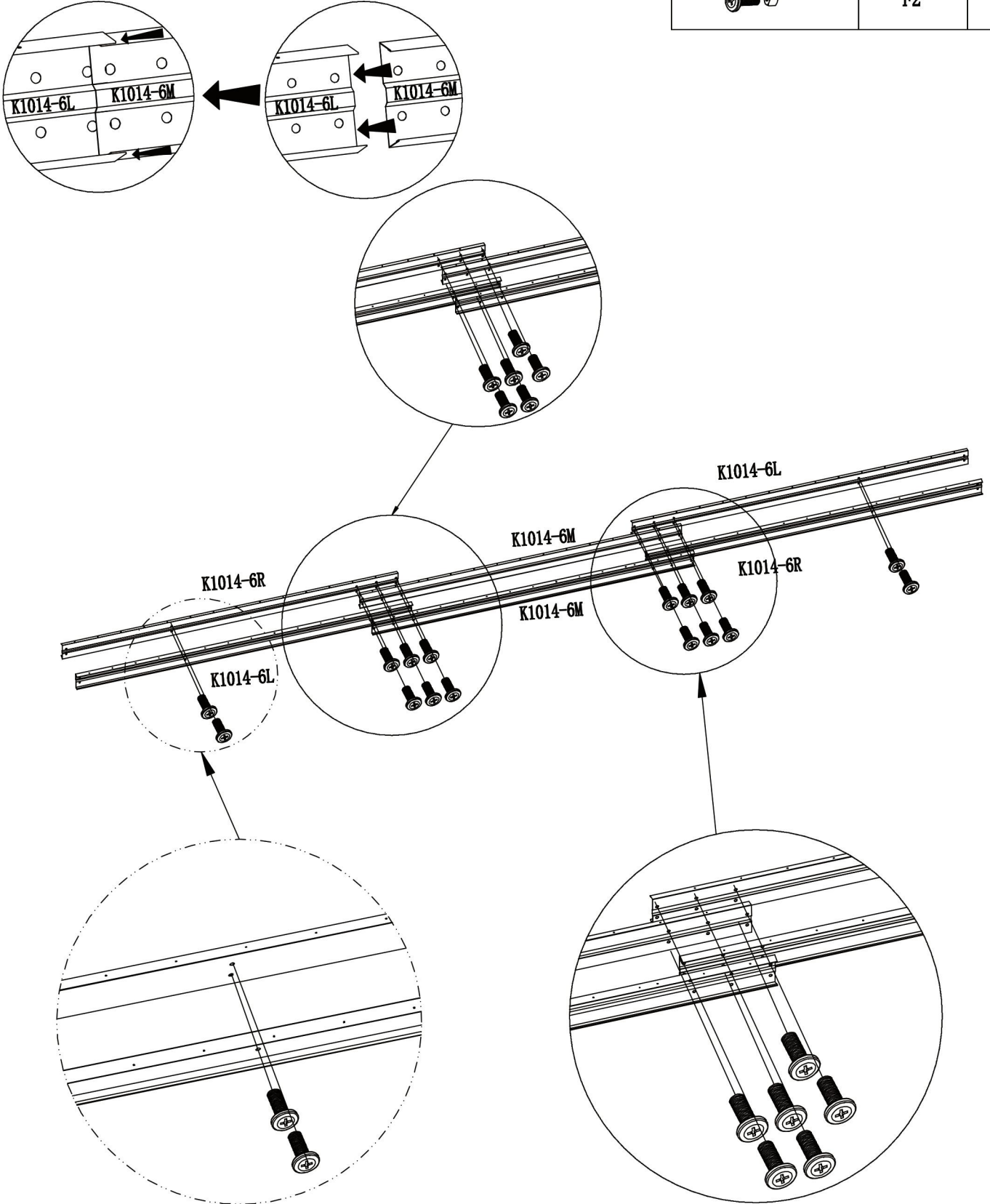



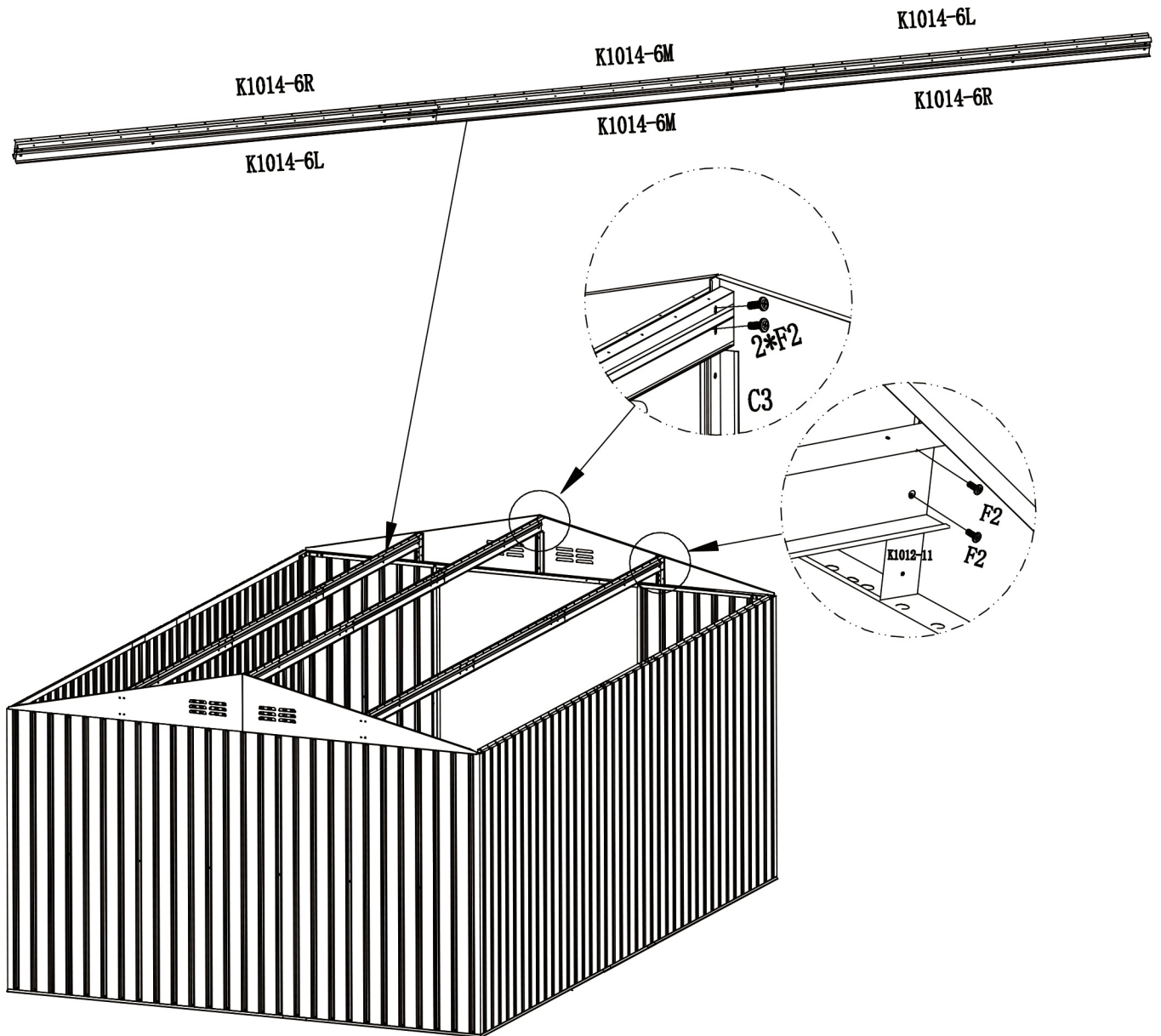

STEP 12

PART	NO.	QTY.
	F2	12



STEP 13

PART	NO.	QTY.
	K1014-7L	2
	K1014-7M	16
	K1014-7R	2
	F1	174
	V2	174

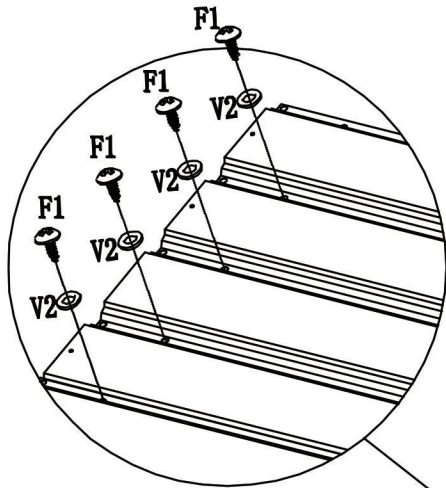
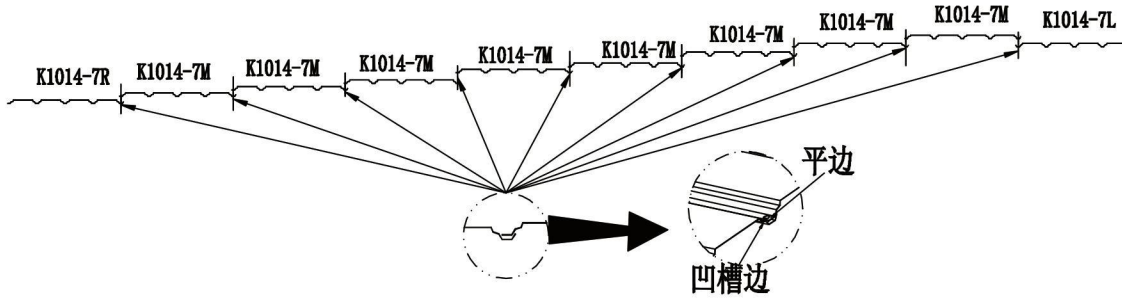

The two board splices in the center of the board are connected to the support beam K1014-6L K1014-6M K1014-6R with F1 screws according to the installation illustration.

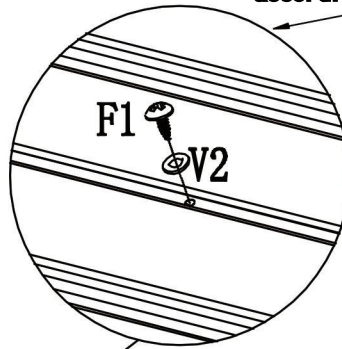



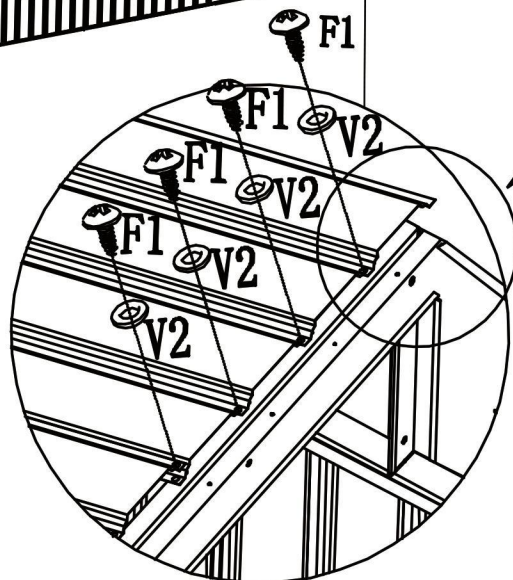
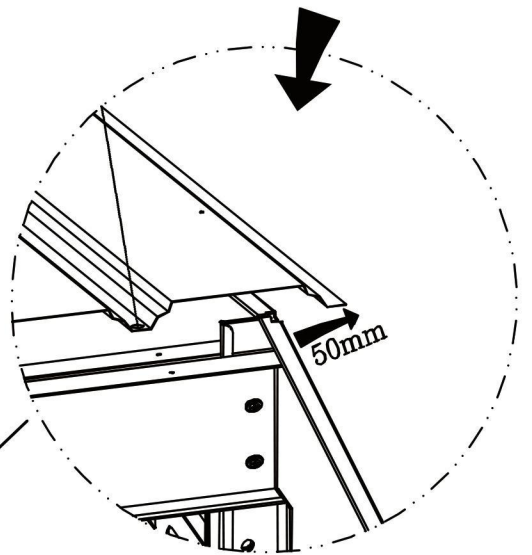
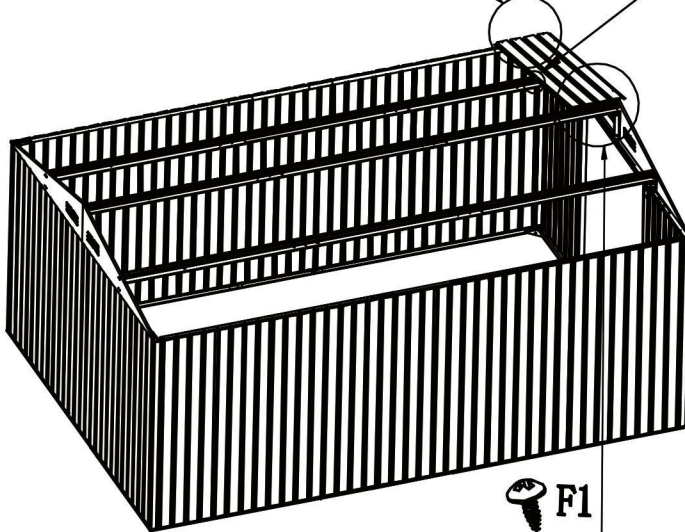

outside

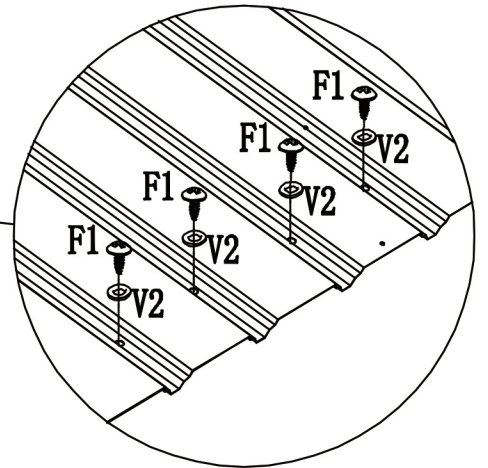
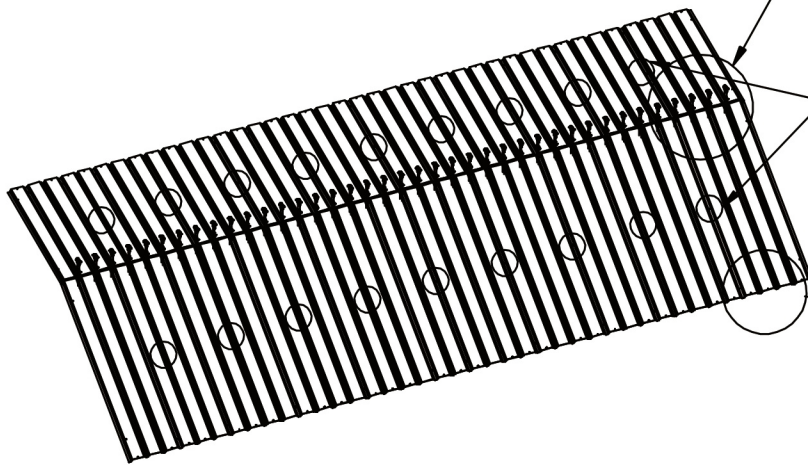
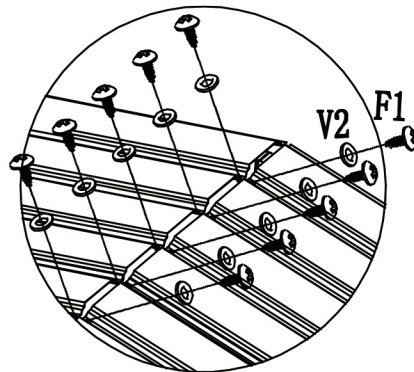
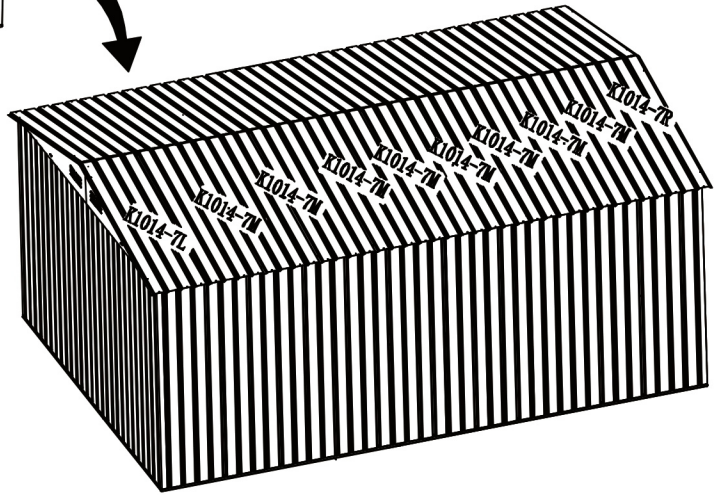
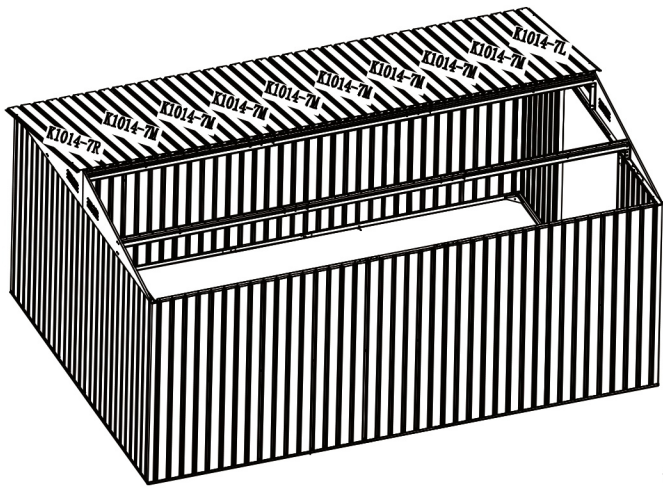
Install as shown:
The edge extends outwards by approx. 50 mm





STEP 14

PART	NO.	QTY.
	K1014-10	2
	K1014-10M	1
	F1	8
	V2	8

According to the illustration: the roof rain sheet 3 formations first with F1 self-tapping screws to connect the number before the subsequent installation

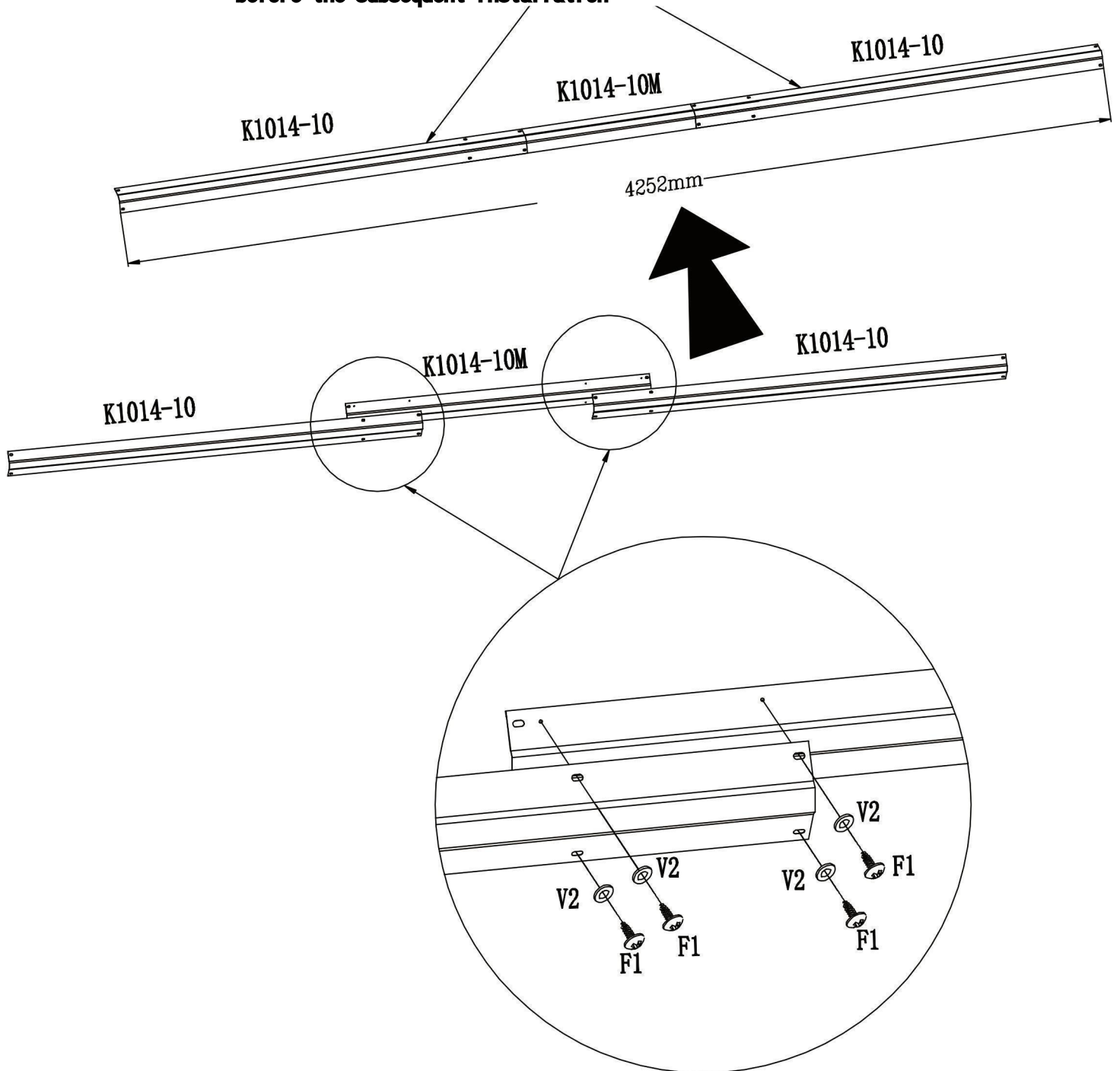

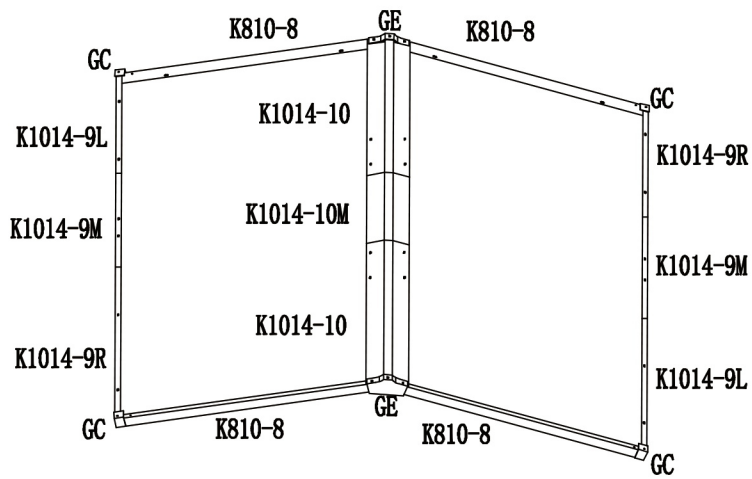

STEP 15

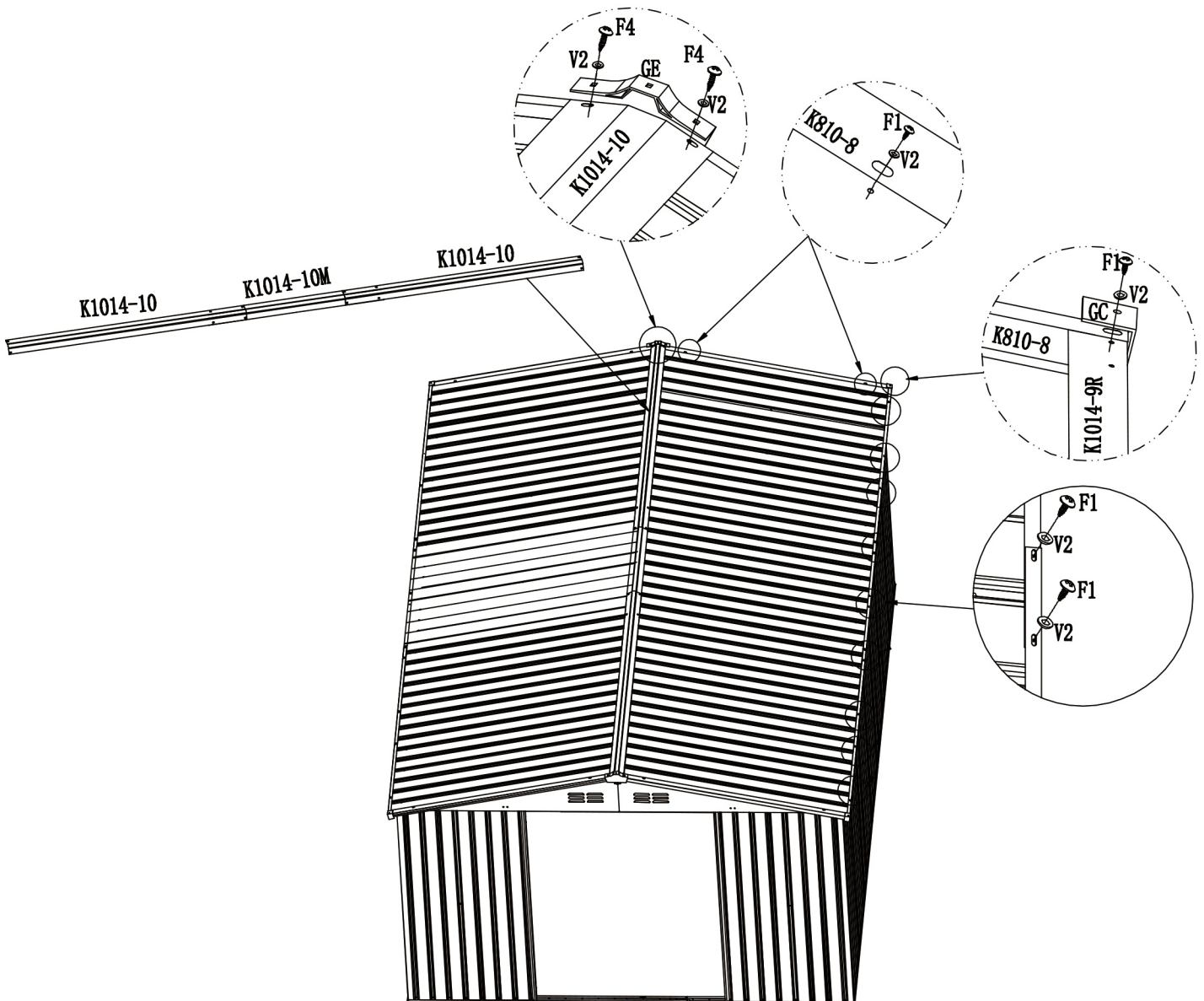

PART	NO.	QTY.
	K810-8	4
	K1014-9L	2
	K1014-9R	2
	K1014-9M	2
	GC	4
	GE	2
	F1	36
	V2	40
	F4	4







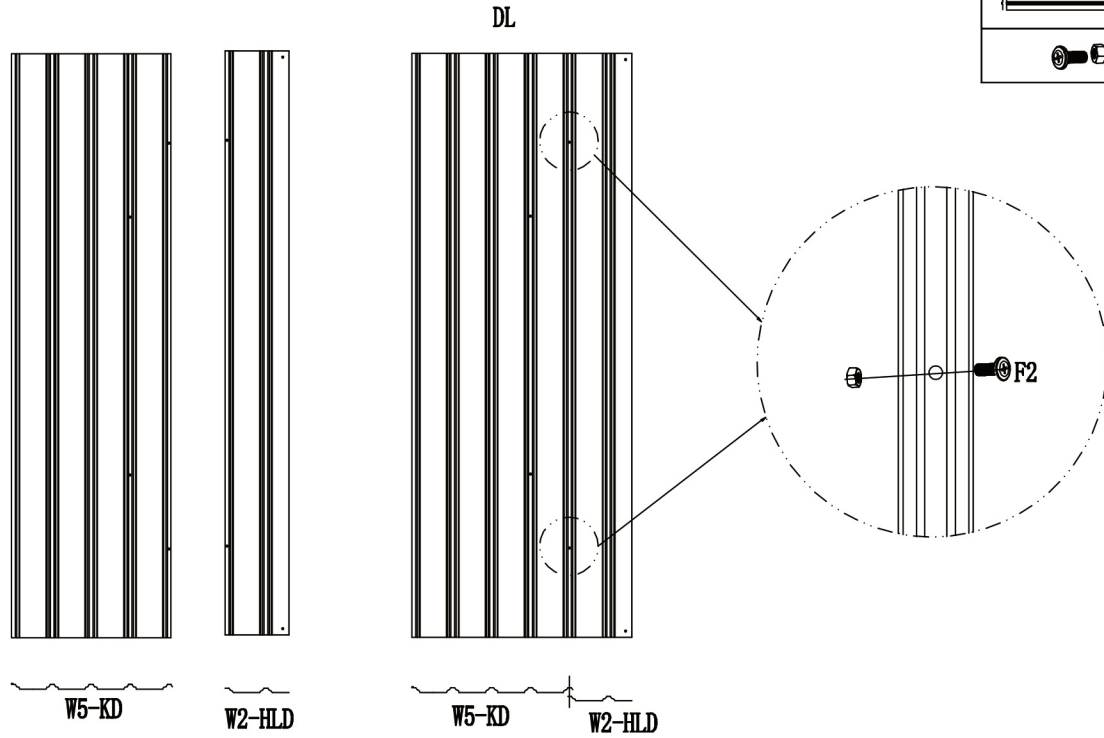

STEP 16

PART	NO.	QTY.
	W5-KD	1
	W2-HLD	1
	F2	2



STEP 17

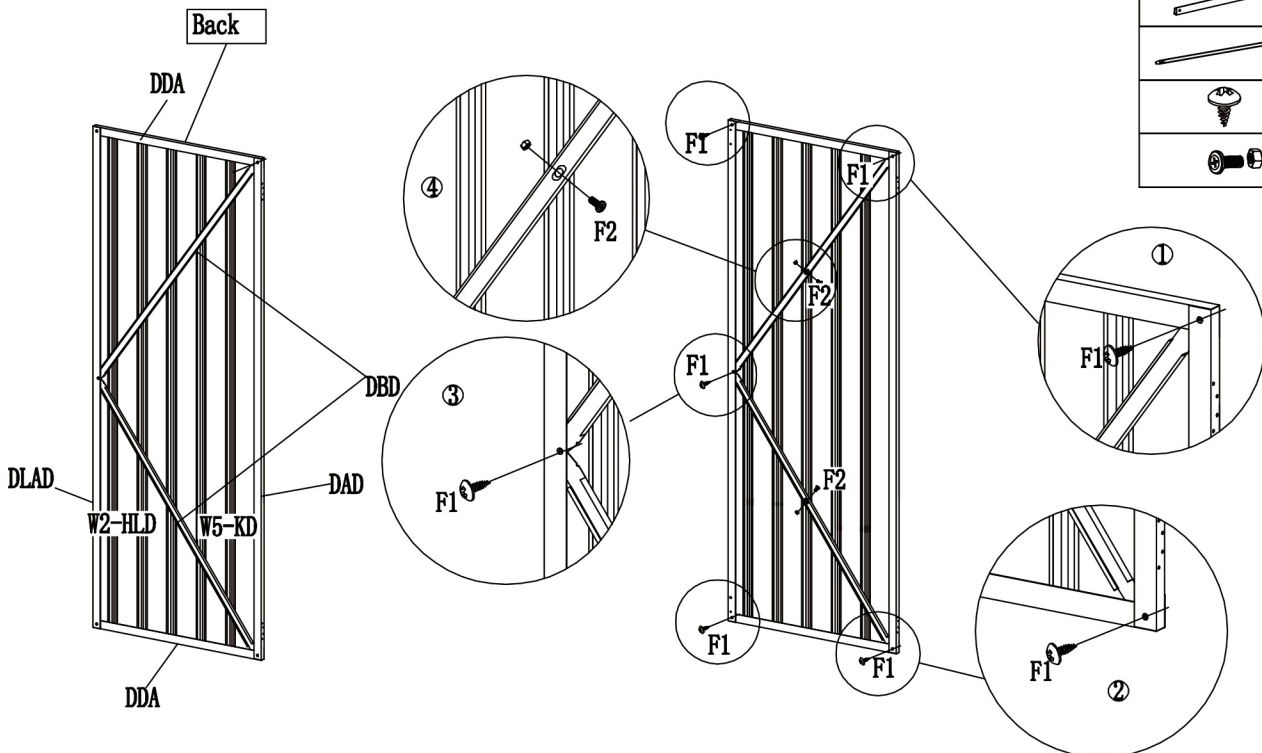

Please follow the steps 1-2-3-4 Install.

PART	NO.	QTY.
	DAD	1
	DLAD	1
	DDA	2
	DBD	2
	F1	9
	F2	2



View from the front, the vertical rod covers the horizontal rod. The larger hole is always covered over the small hole.





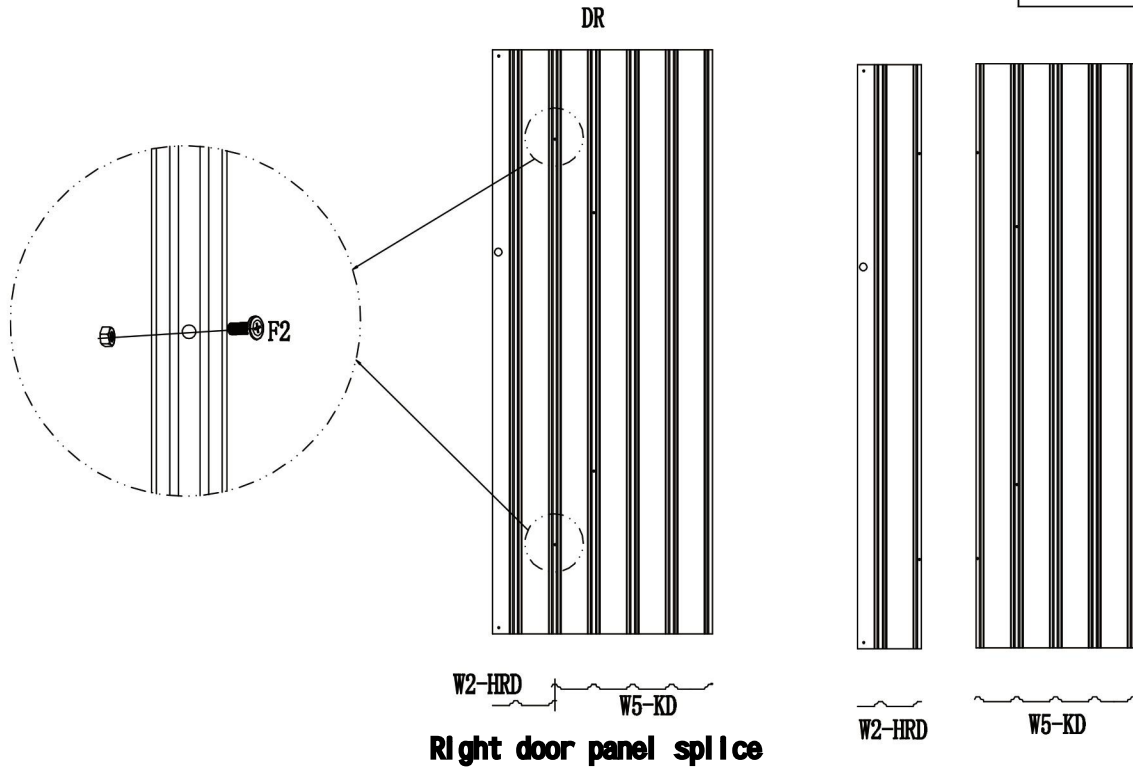

STEP 18

PART	NO.	QTY.
	W5-KD	1
	W2-HRD	1
	F2	2



STEP 19



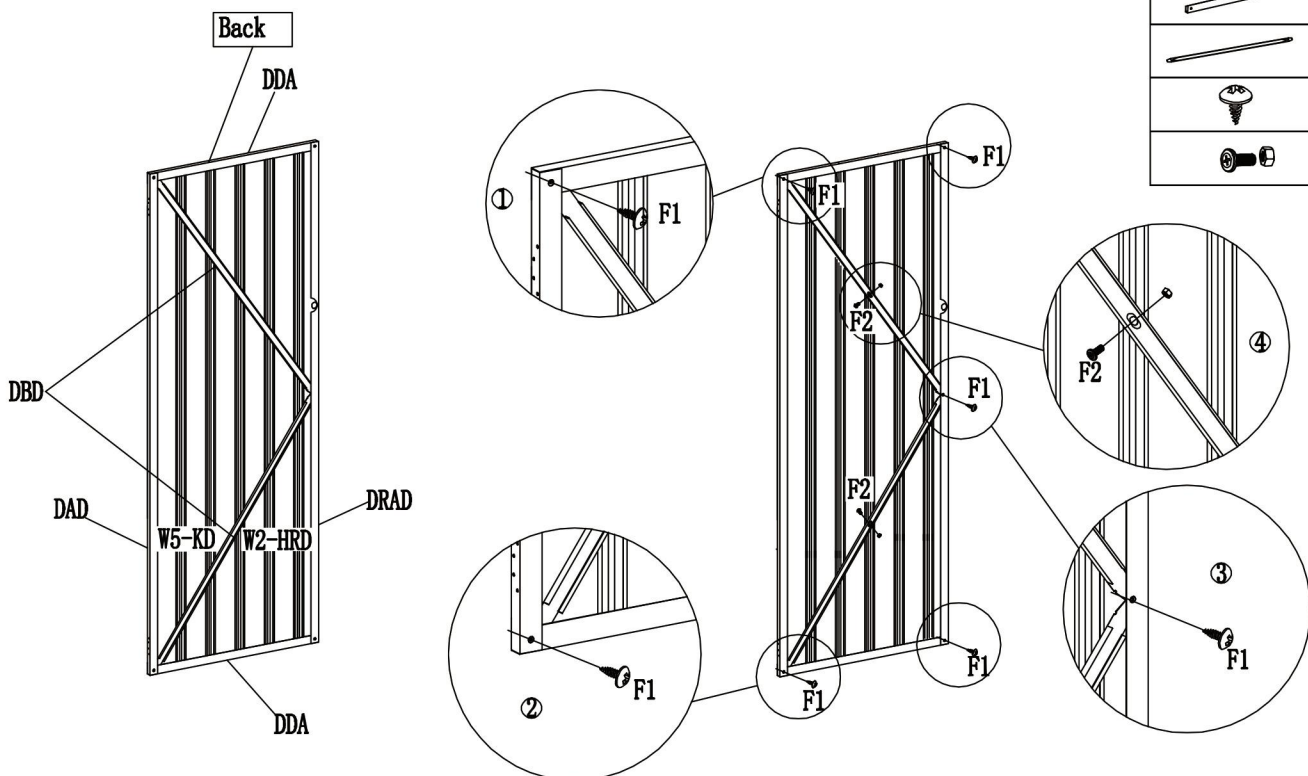

Please follow the steps 1-2-3-4 Install.

PART	NO.	QTY.
	DAD	1
	DRAD	1
	DDA	2
	DBD	2
	F1	9
	F2	2





The final fixation should be done after all parts are aligned.

STEP 20

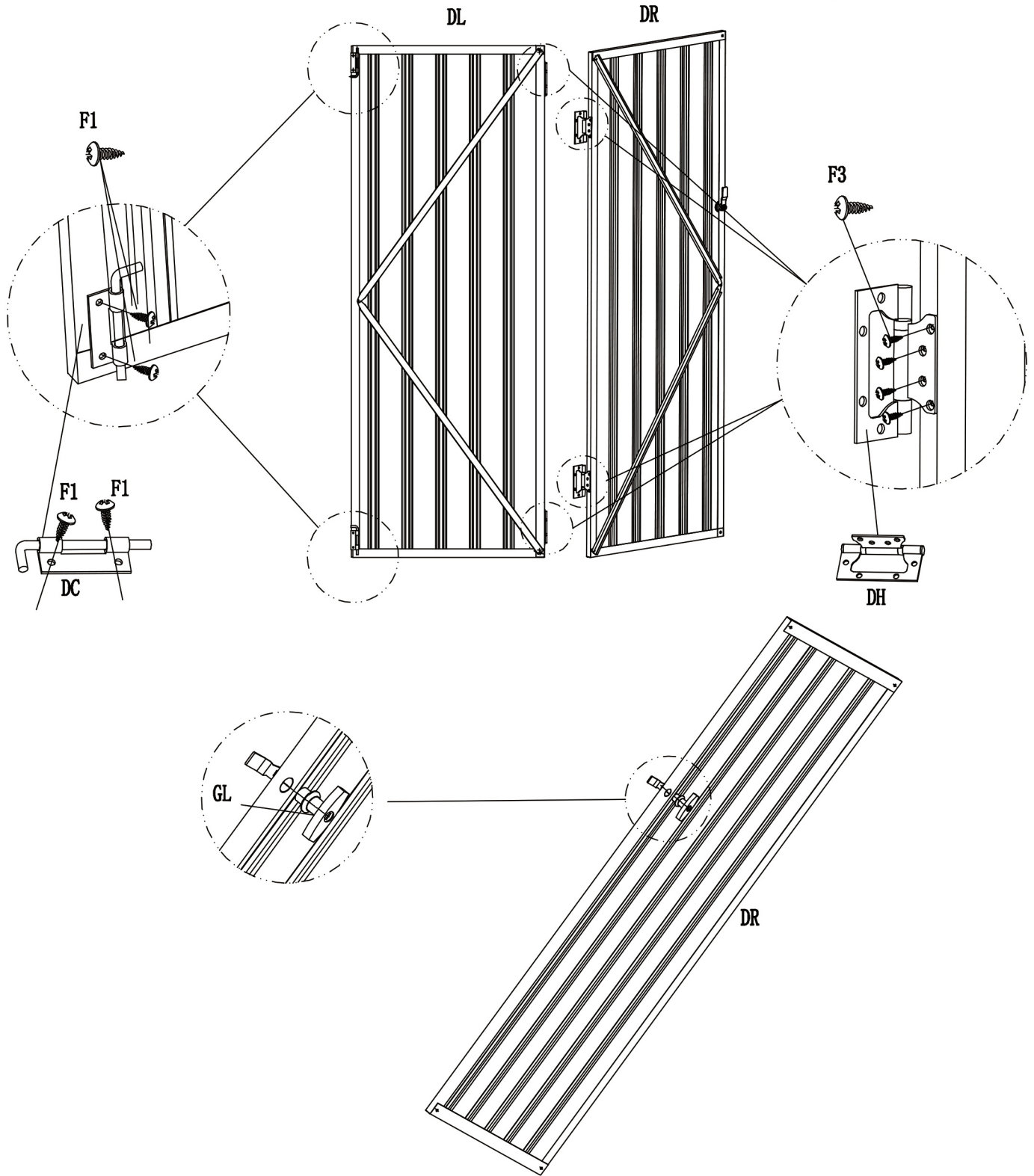
PART	NO.	QTY.
	DH	4
	DC	2
	F3	16
	GL	1
	F1	4



STEP 21

PART	NO.	QTY.
	DL	1
	DR	1
	F3	16

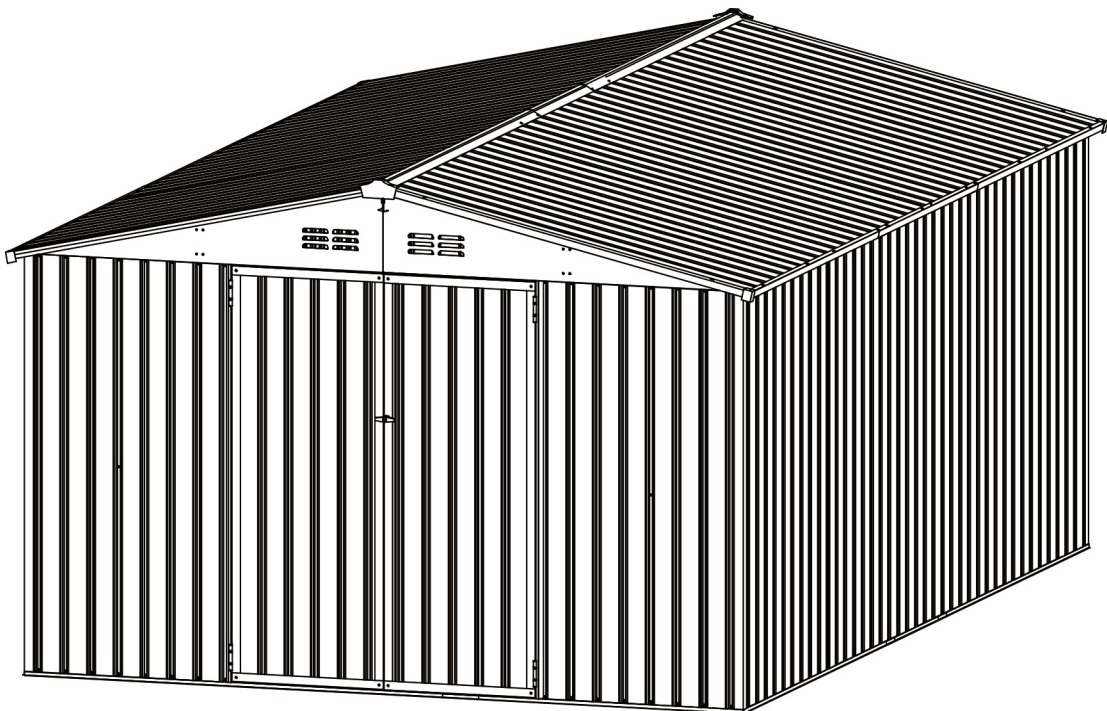
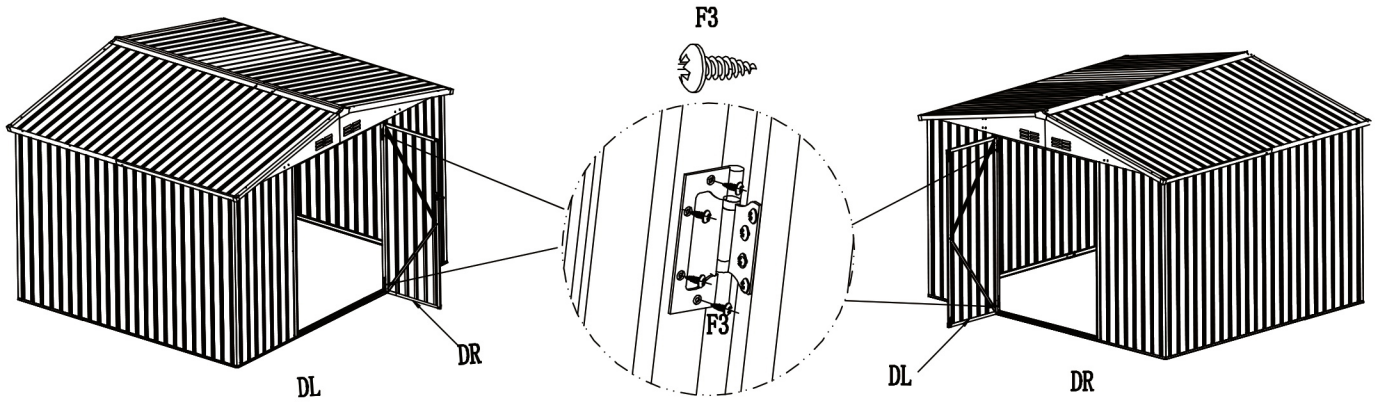

STEP 22

PART	NO.	QTY.
	SL	112

Plastic protective caps are required for the exposed portion of the upper cross member support bar K1012-11 assembly screws.

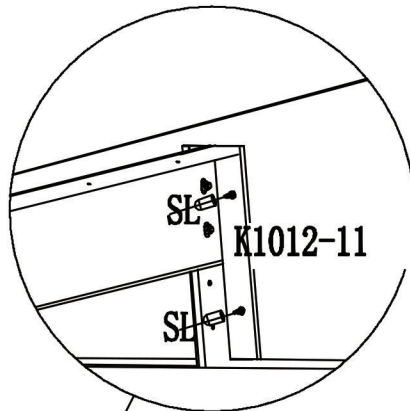

Upper cross member K1014-6L K1014-6M K1014-6R and top cover Plastic protective sleeve is required for the exposed part of the mounting screws.

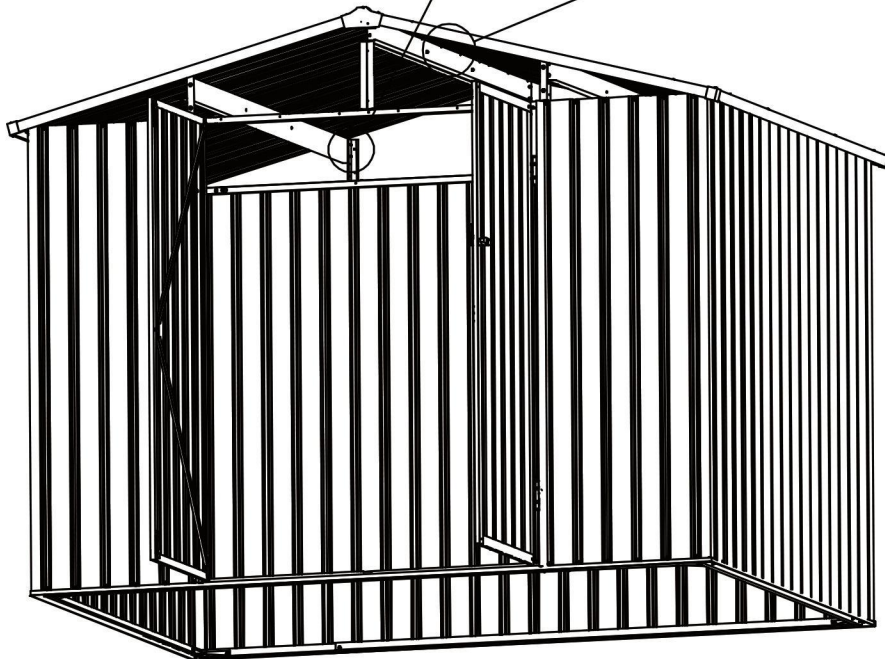
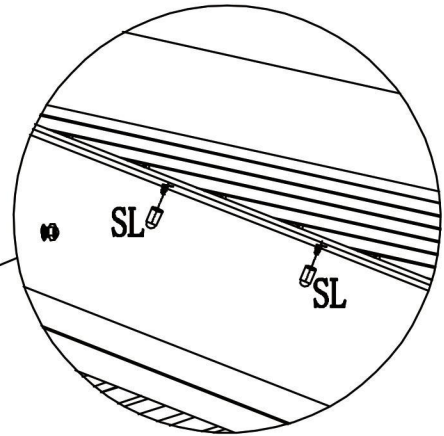

Metal Storage Shed Plastic Floor Installation Instruction

SSH10142-PF

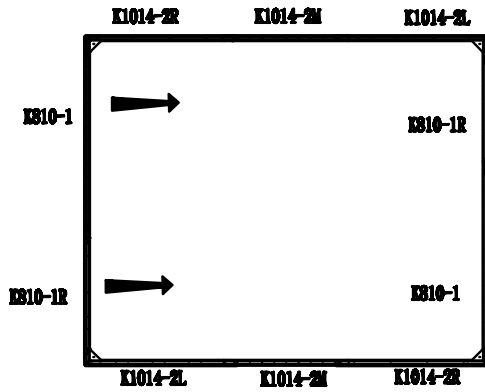

PART	NO.	QTY.
	K1014-DL	1
	K1014-DL1	1
	K1014-DR	1
	K1014-DR1	1
	K1014-DM	16
	DM-850	4
	DM-640	1
	F1	42

Self-tapping screws

