

METAL BED FRAME

ASSEMBLY INSTRUCTIONS

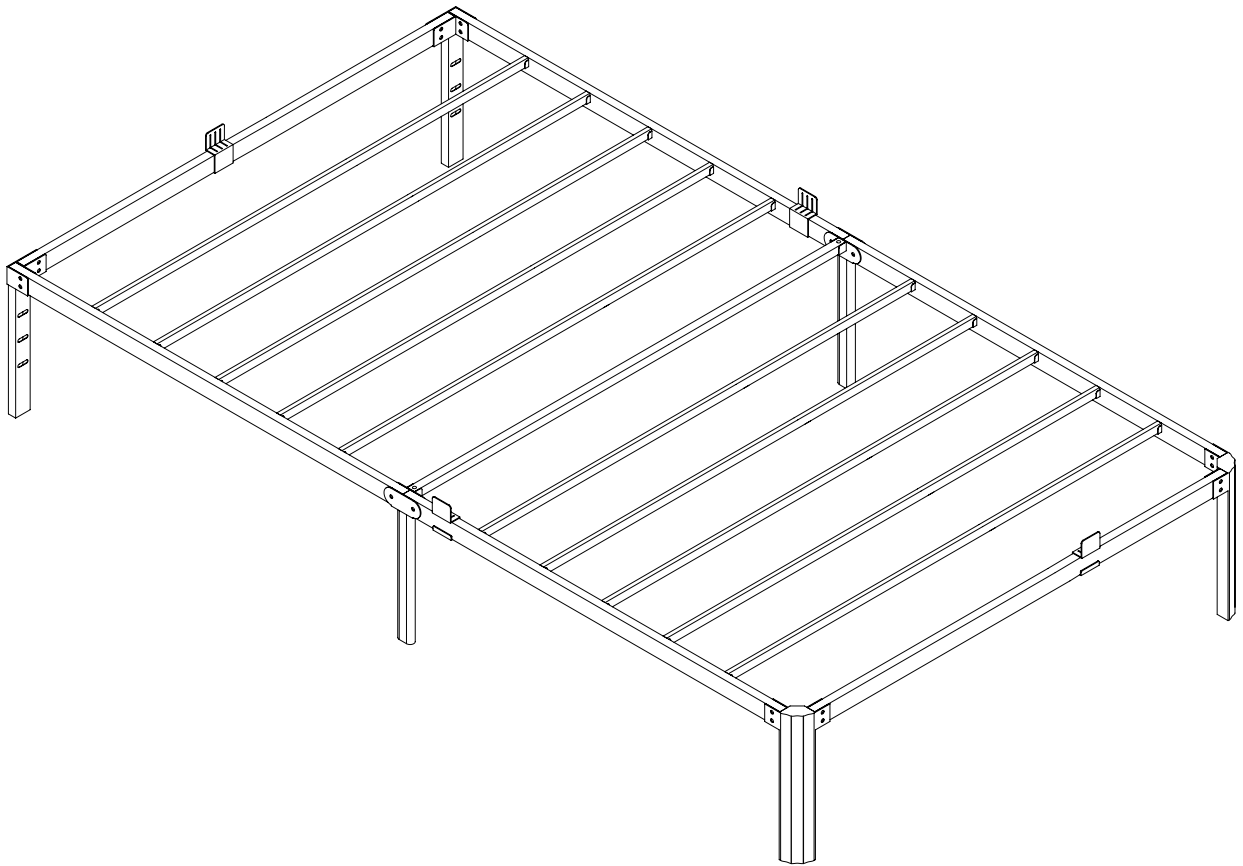

ASSEMBLY INSTRUCTIONS

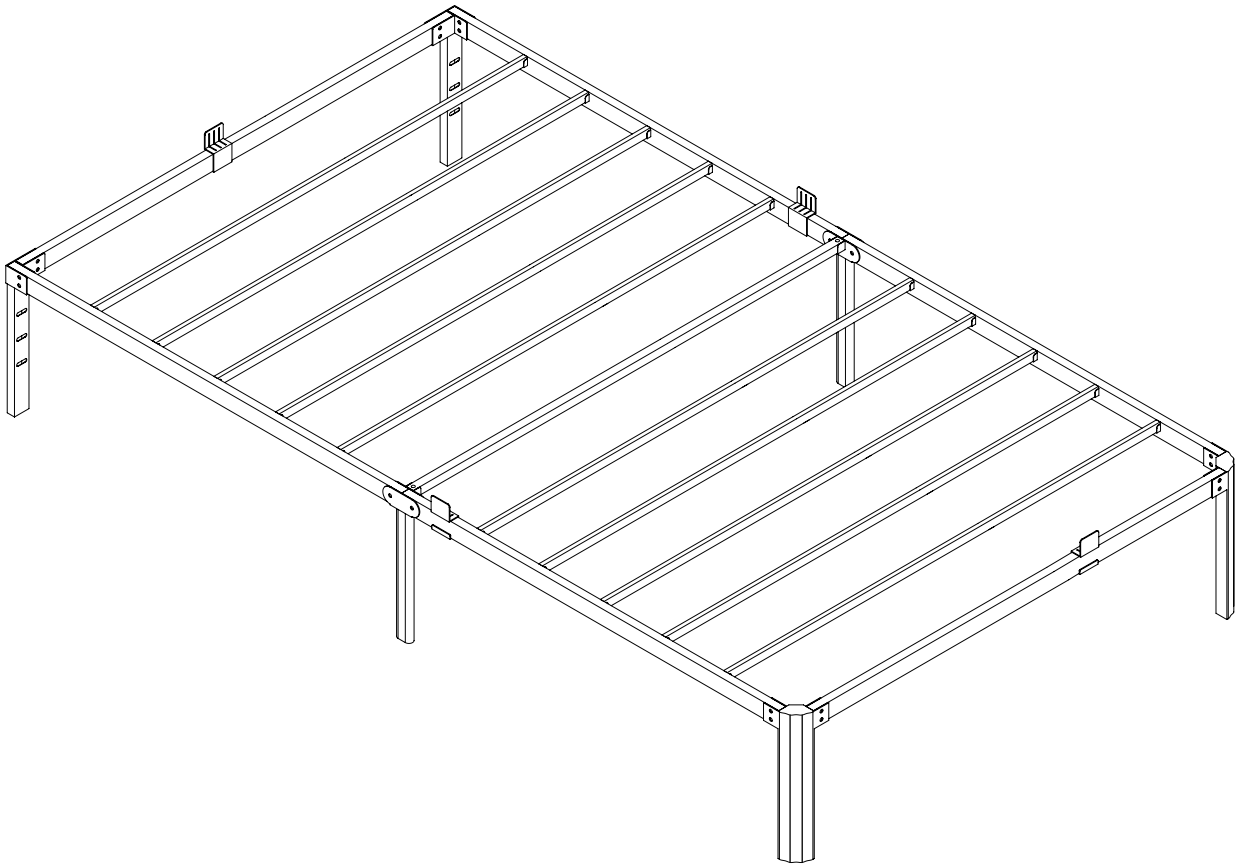

PLEASE DO NOT DISPOSE OF PACKAGING MATERIAL UNTIL THE CONTENTS HAVE BEEN EXAMINED!

NOTES:

Do not skip any step.

Do not fully tight screws until all the bed parts are assembled.

WARNING:

WARNING FOR YOUNG CHILDREN-This product contains small components, please ensure that they are kept away from children while assembling.

RETURN POLICY

Appreciate your selection of the our bed frame. Hope you are satisfied with your purchase.

However, if for some reason you would like to return the item, please contact us before deciding to do so. Our customer service team can answer most questions and assist you with the assembly process.

SITUATION

Any problems are found at the time of delivery:

- Product missing accessories/parts at the time of delivery.
- Defects in the manufacturing of materials used for the product.
- Damaged parts/components due to damaged packaging on delivery.

Problems during installation:

- The inaccurate pairing of bolts and holes during installation.
- Difficulty or failure during installation.
- After installation, the bed frame shakes seriously.

SOLUTIONS



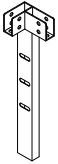
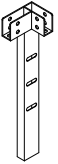
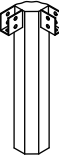
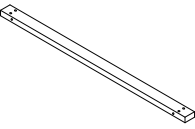
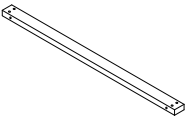
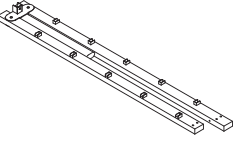
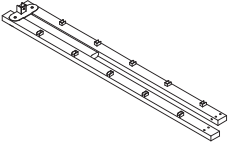
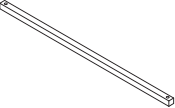
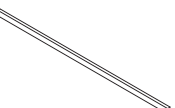
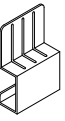

According to different issues we provide 3 options:

- New parts replacement with fast delivery.
- Partial refund for compensation.
- New one exchanged.

PART LIST

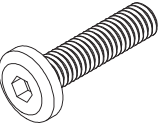
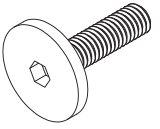
<p>A</p>  <p>x1</p>	<p>B</p>  <p>x1</p>	<p>C</p>  <p>x2</p>	<p>D</p>  <p>x1</p>	<p>E</p>  <p>x1</p>
<p>F</p>  <p>x1</p>	<p>G</p>  <p>x1</p>	<p>I</p>  <p>x1</p>	<p>J</p>  <p>x10</p>	<p>K</p>  <p>x4</p>

TOOL ACCESSORIES

<p>a</p>  <p>M8*35 x18</p>	<p>b</p>  <p>M6*16 x8</p>	<p>c</p>  <p>M8 x18</p>	<p>d</p>  <p>x1</p>	<p>e</p>  <p>x1</p>
--	---	--	--	---

EXPLODED VIEW OF PRODUCT PARTS

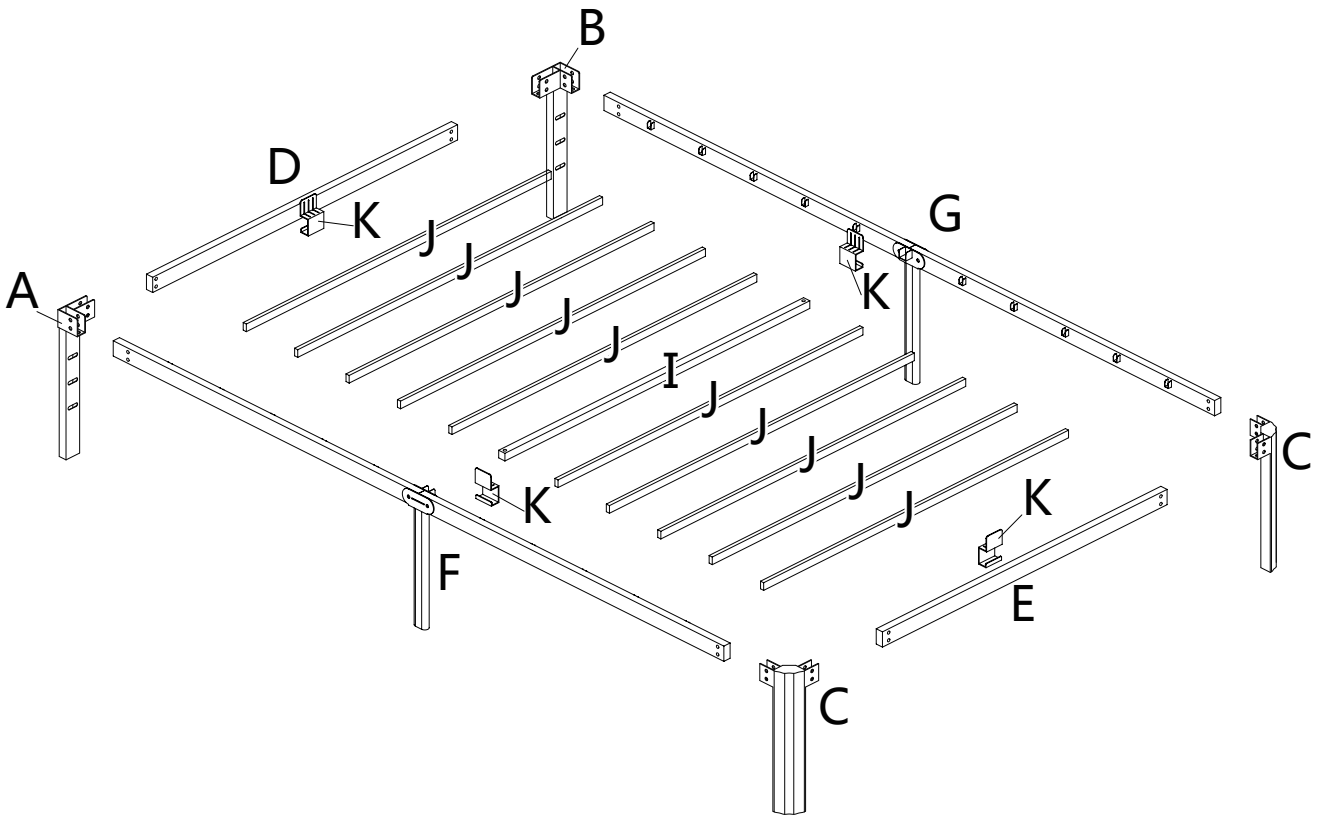
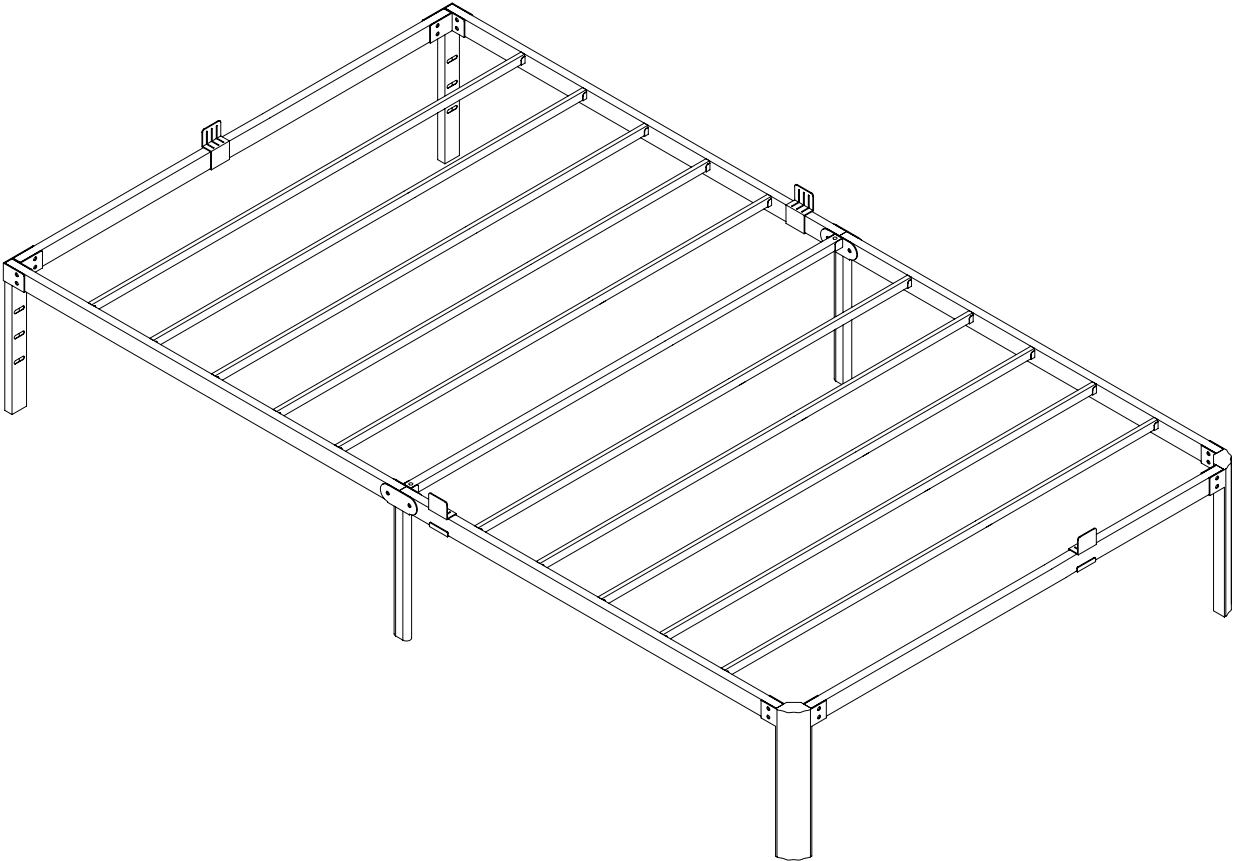

Step 01



M6*16
b)x2pcs

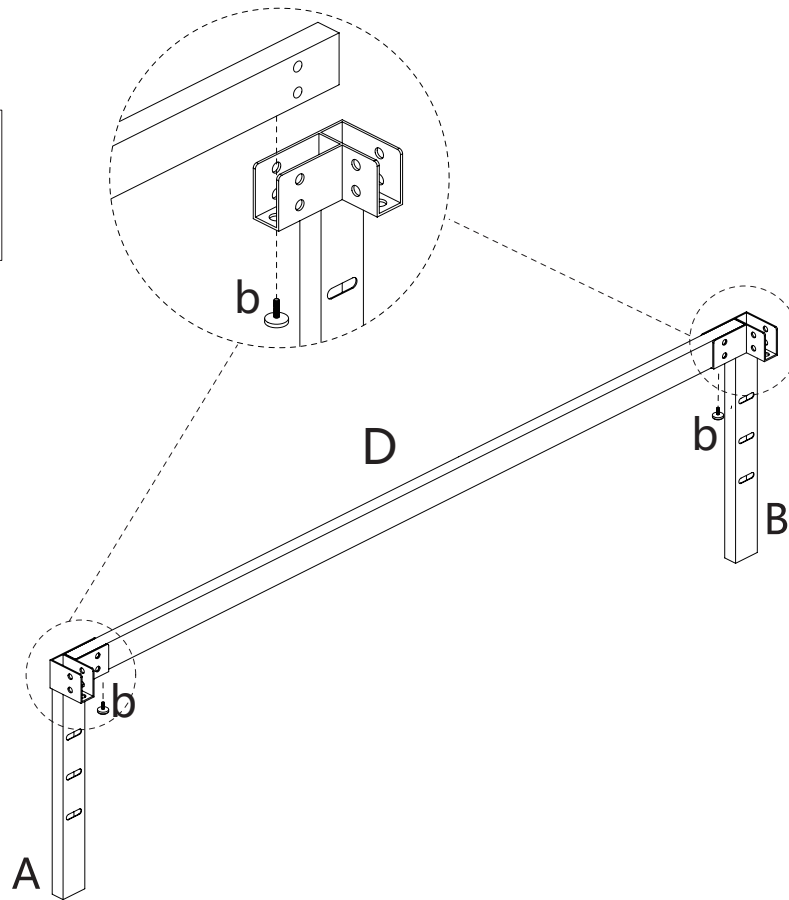
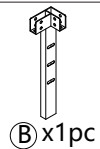
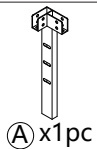

Step 02



M6*16
b)x2pcs

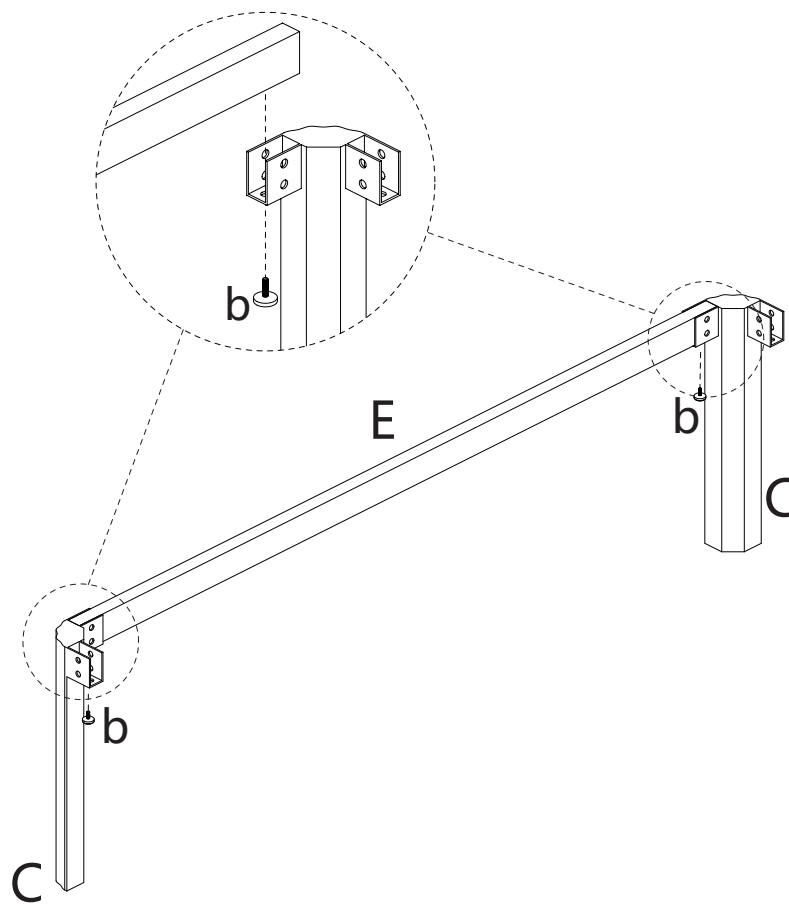
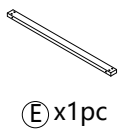

Step 03

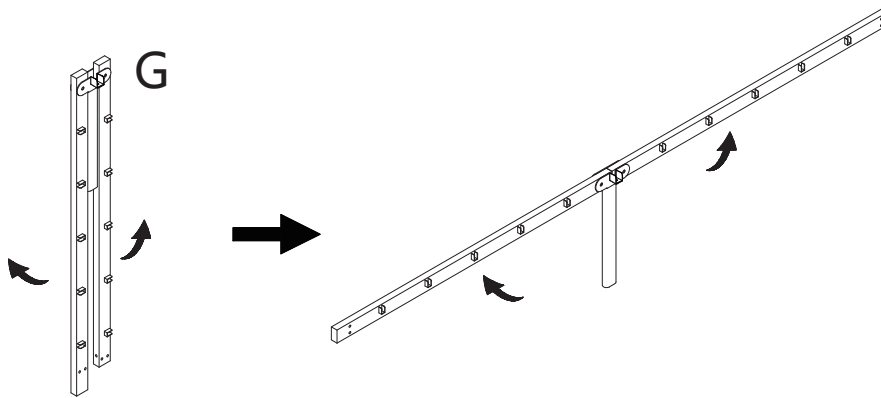
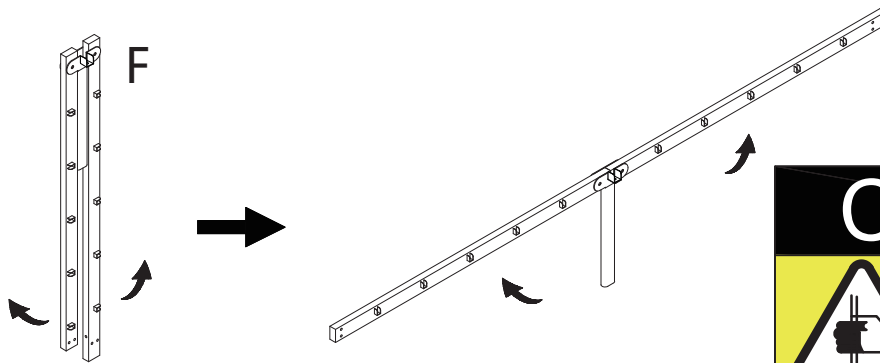

Step 04

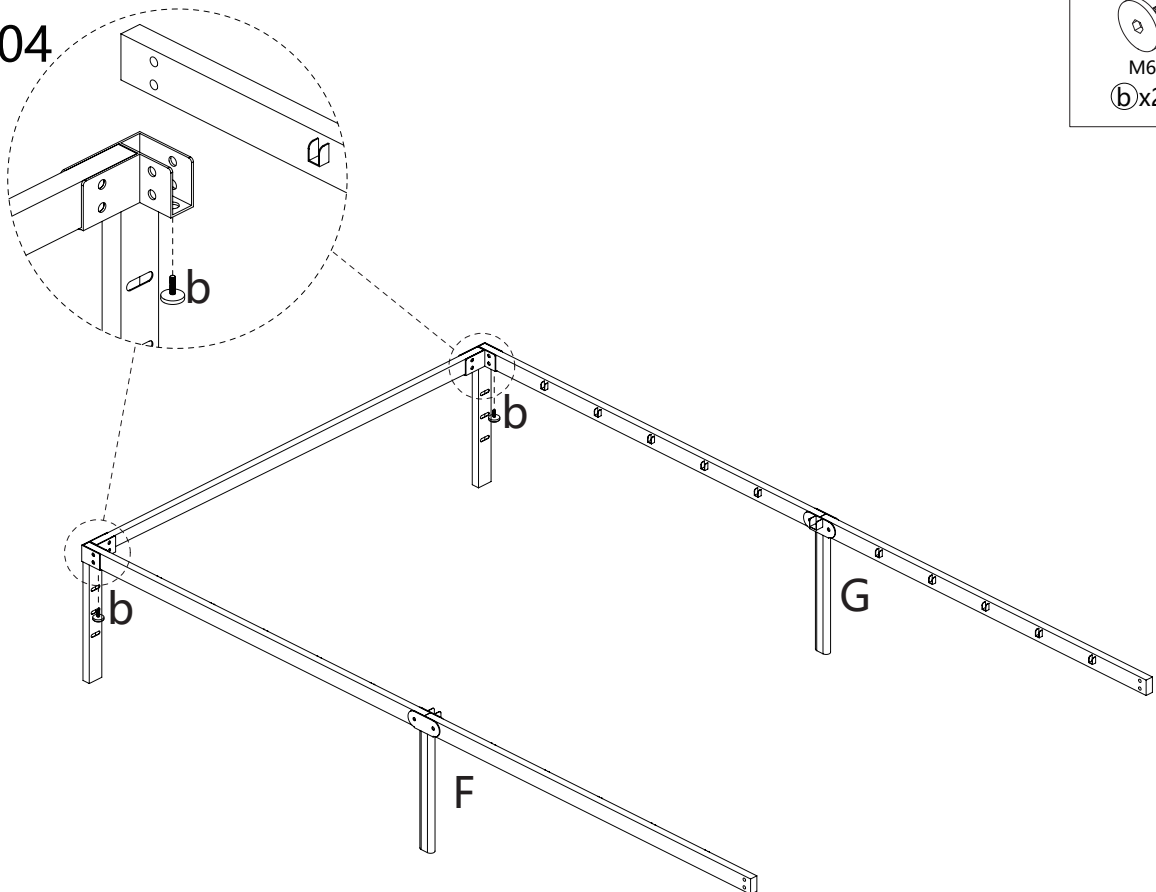

Step 05



M6*16
b)x2pcs

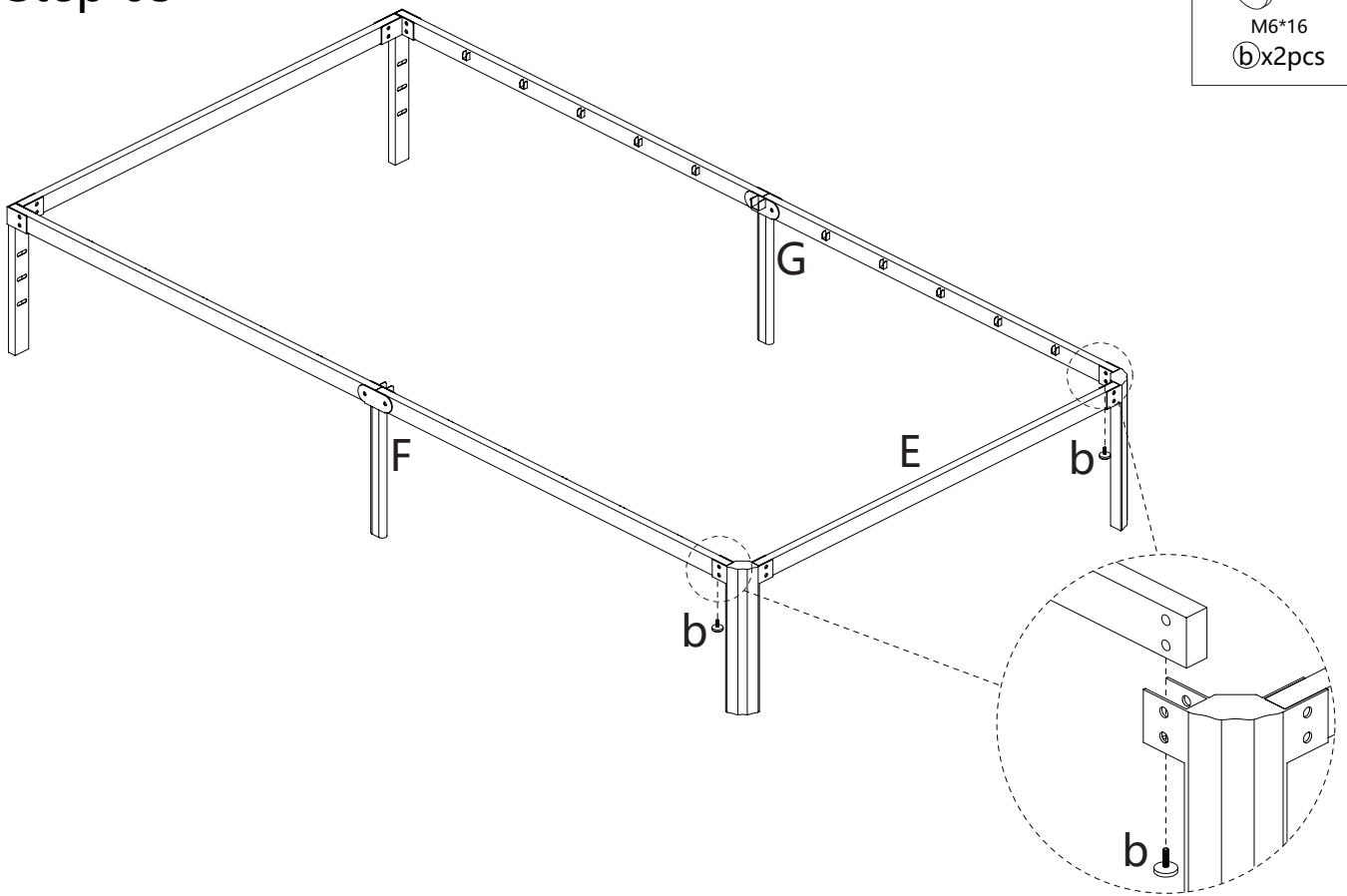

Step 06



M8*35
a)x16pcs



M8
c)x16pcs

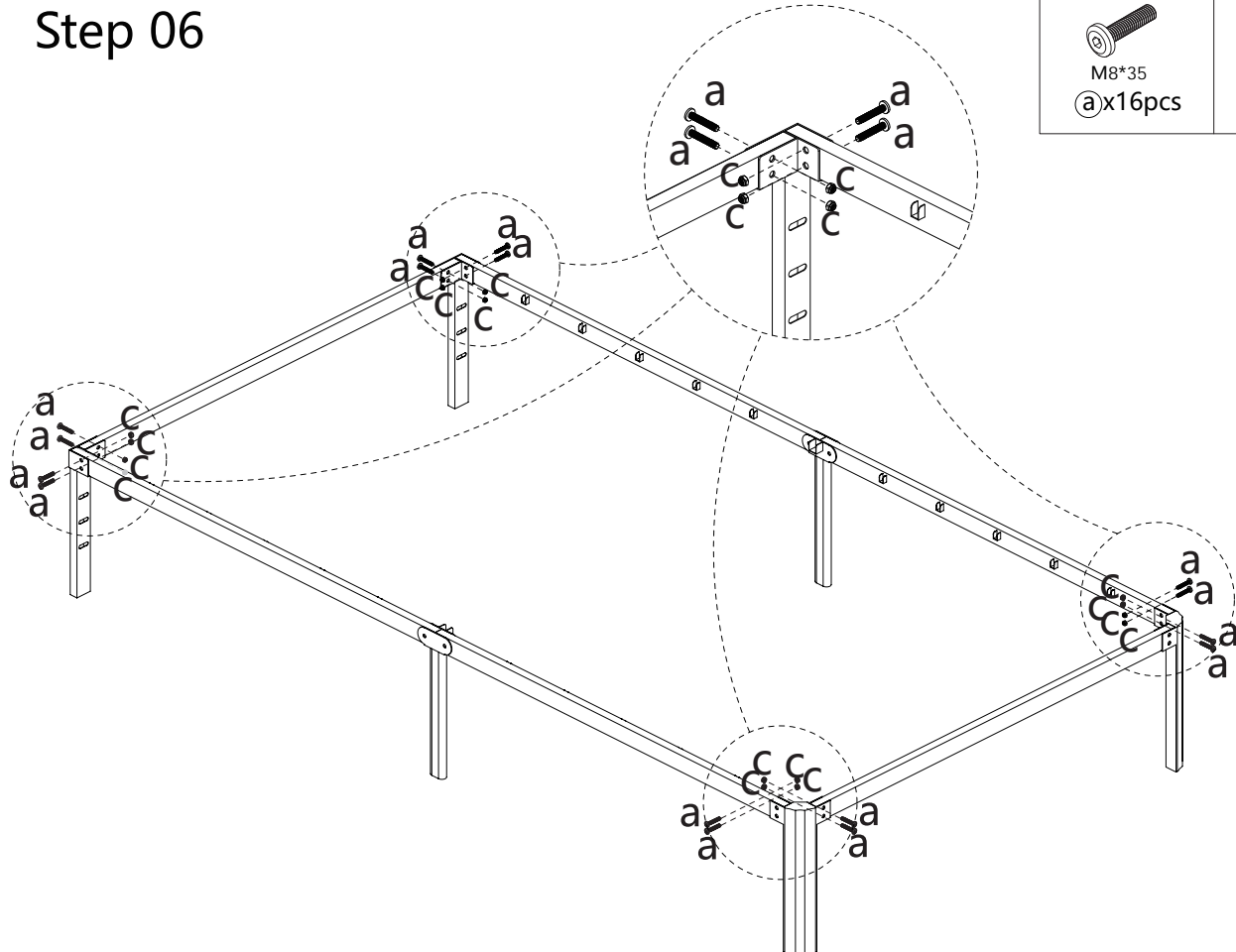

Step 07

M8*35
a x2pcs

M8
c x2pcs

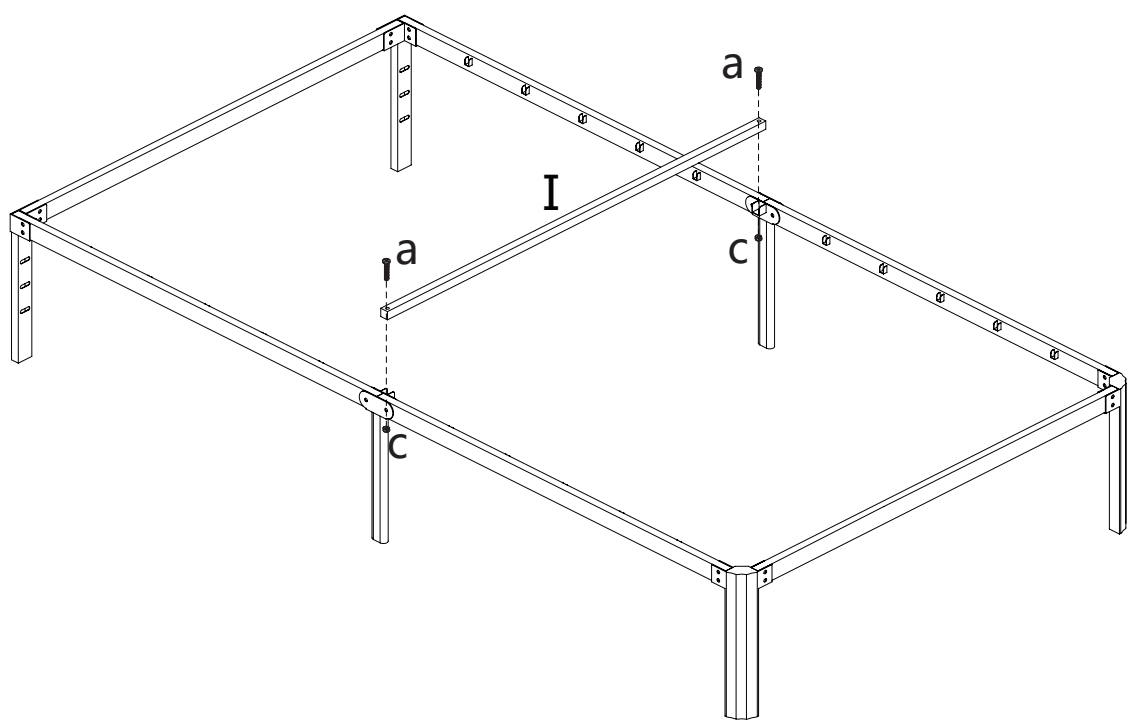

Step 08

