

ASSEMBLY INSTRUCTIONS

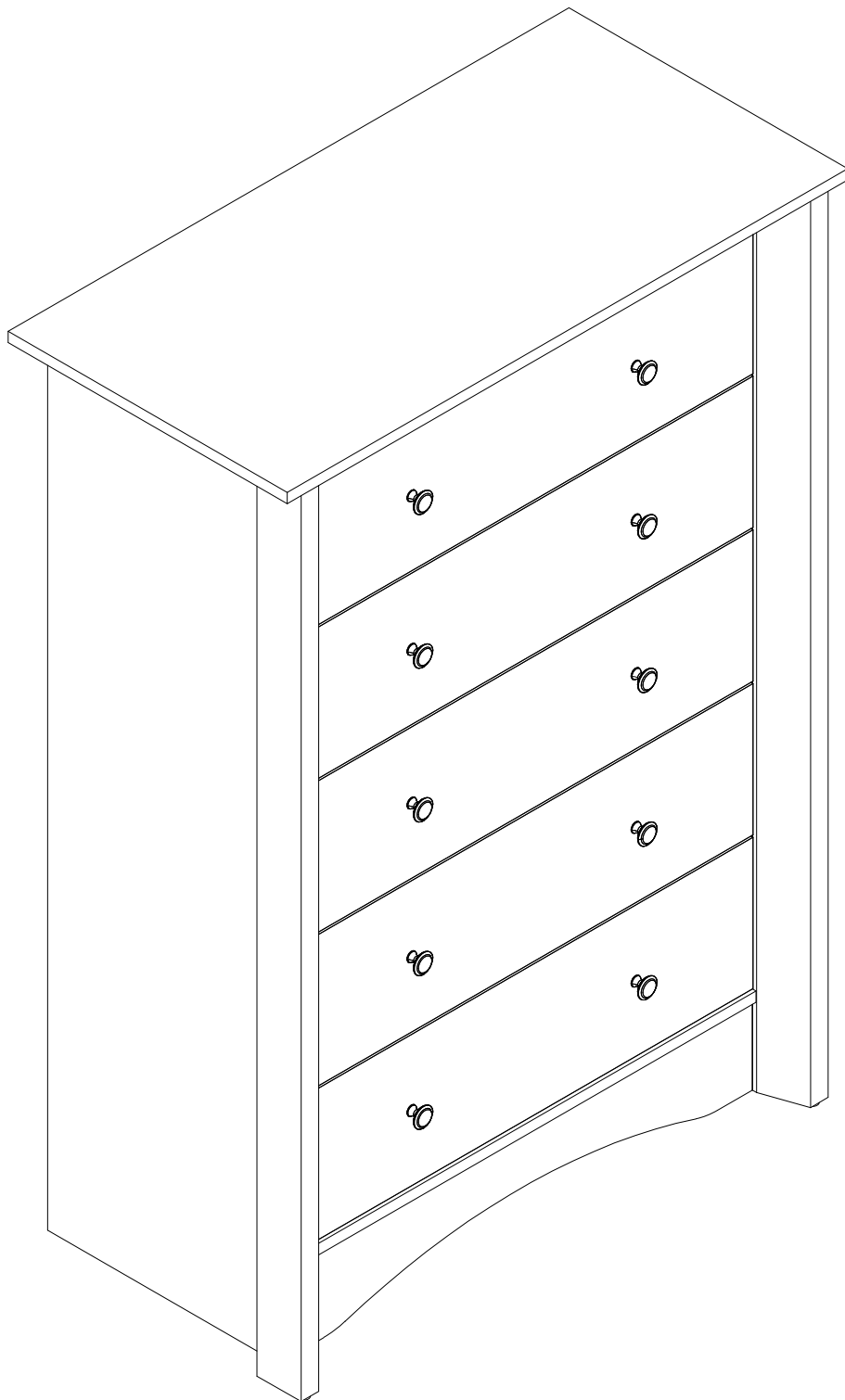

WARNING !

MAXIMUM LOAD
220 lb/ 100kg



Estimated Time for Assembly

60 mins

MAXIMUM LOAD
20 lb/ 9.1kg

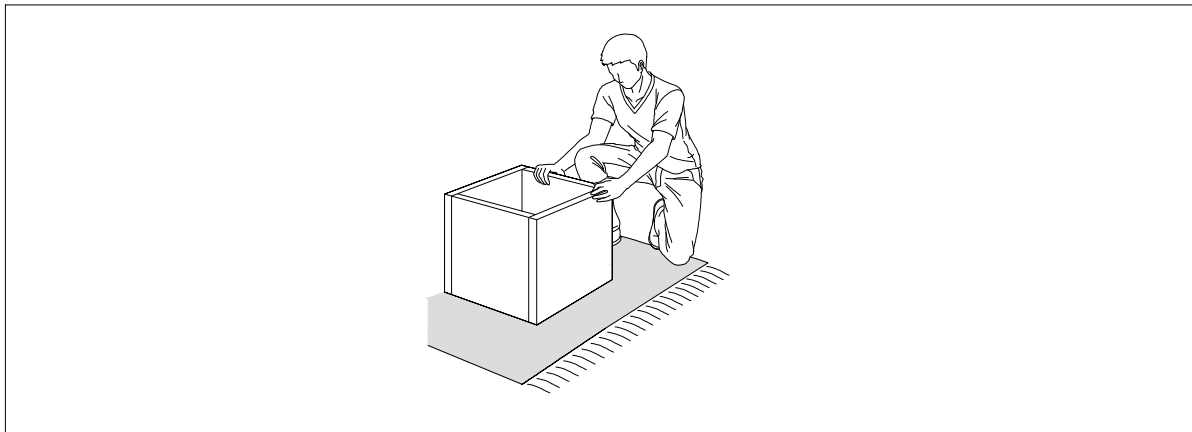

Assemble the furniture on empty carton, carpet, or rug to prevent scratches or damage.

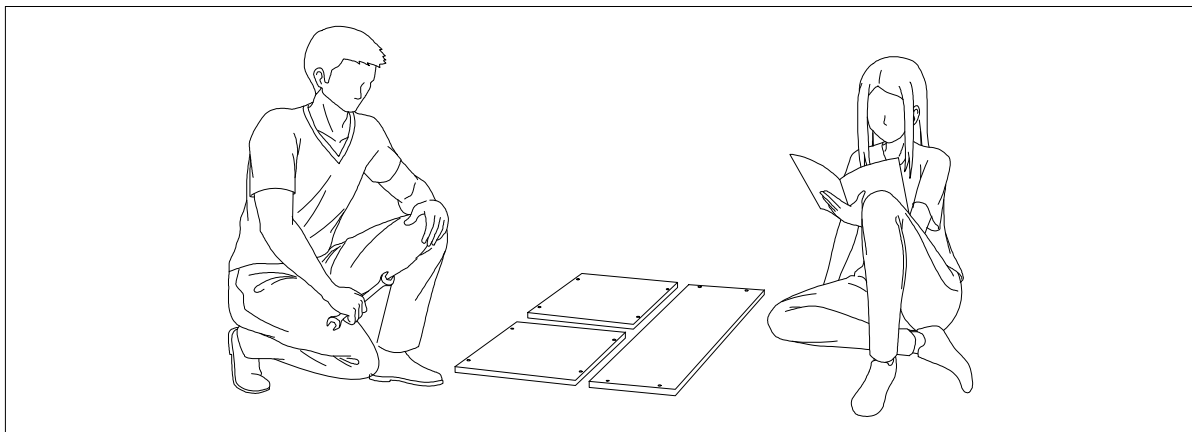

This furniture requires 2 people to assembly.

Make sure no parts are missing or damaged before assembly.

Board Identification

Not actual size

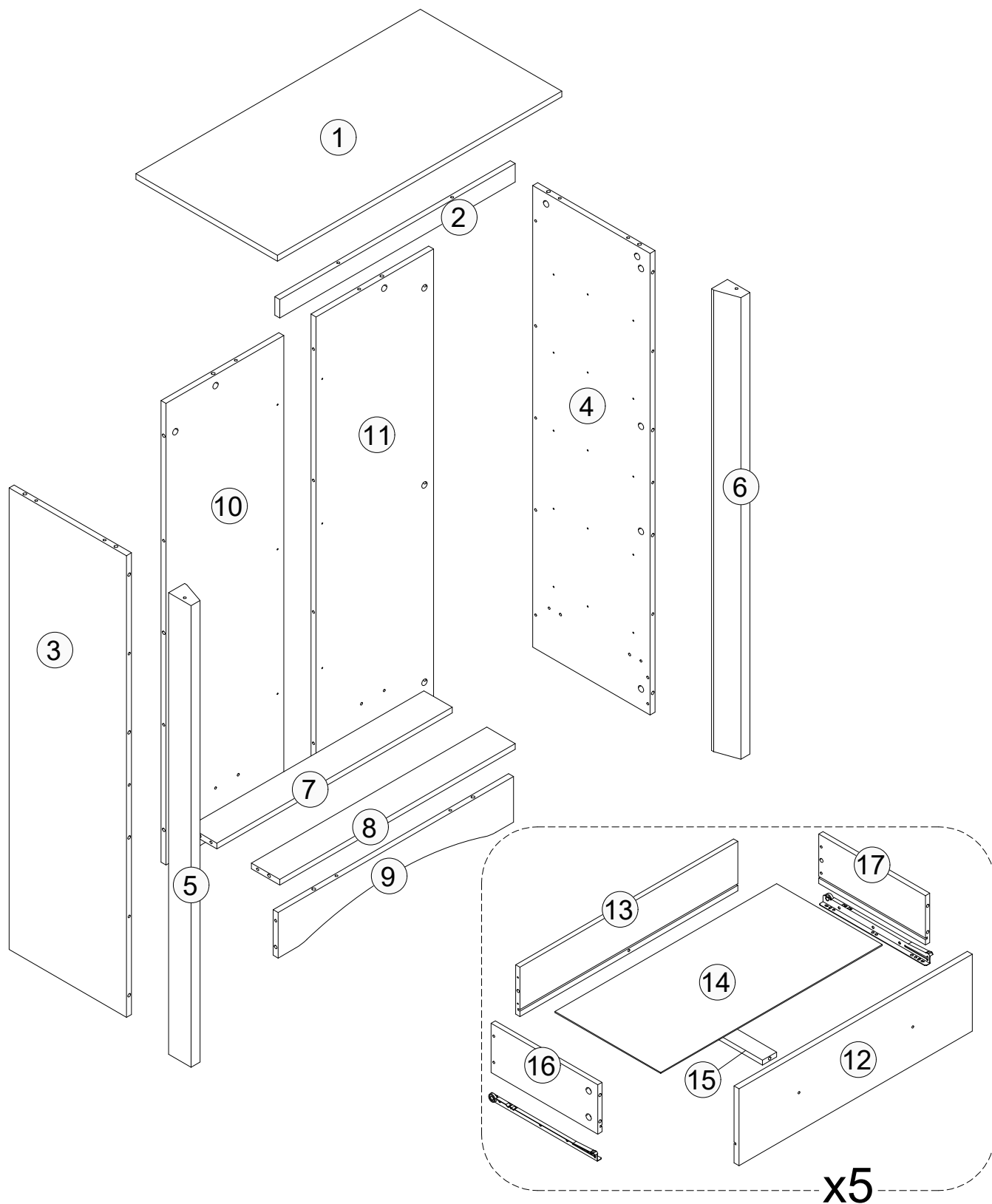

BOARD IDENTIFICATION

Not actual size

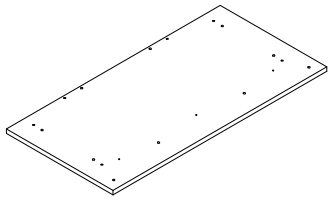

① x1

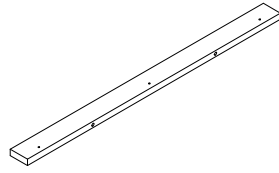

② x1

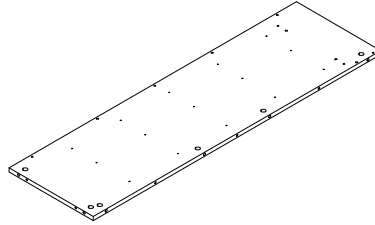

③ x1

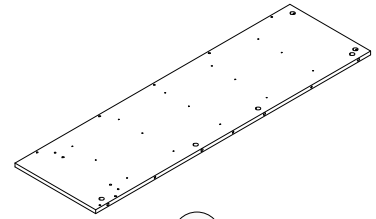

④ x1

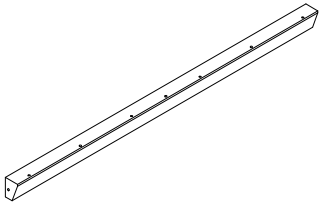

⑤ x1

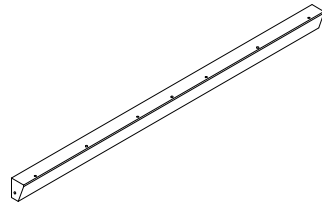

⑥ x1

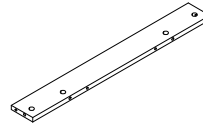

⑦ x1

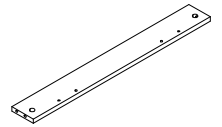

⑧ x1

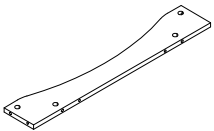

⑨ x1

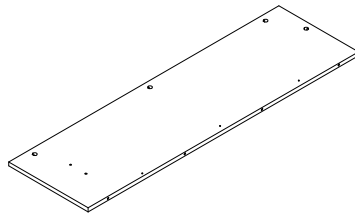

⑩ x1

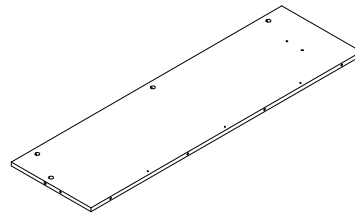

⑪ x1

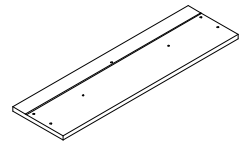

⑫ x5

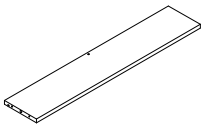

⑬ x5

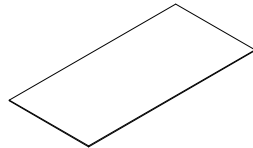

⑭ x5

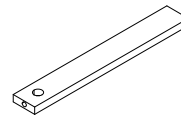

⑮ x5

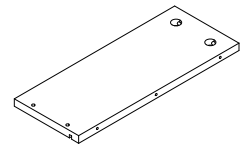

⑯ x5

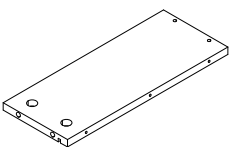

⑰ x5

HARDWARE LIST

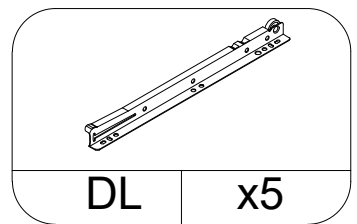
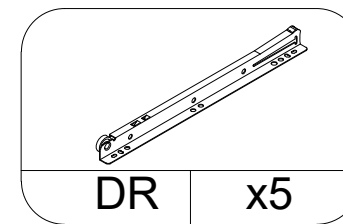
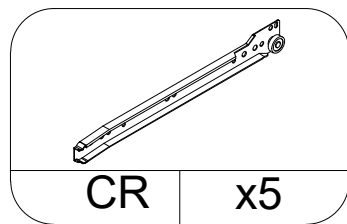
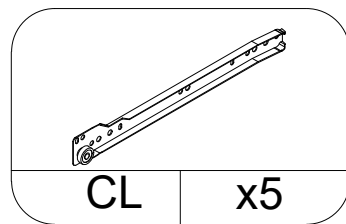
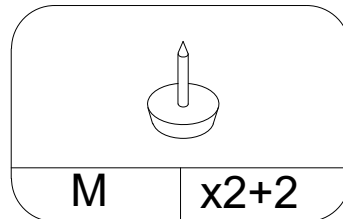
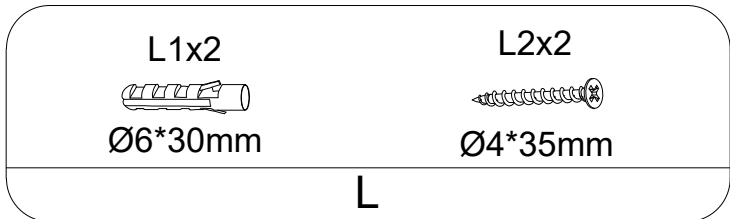
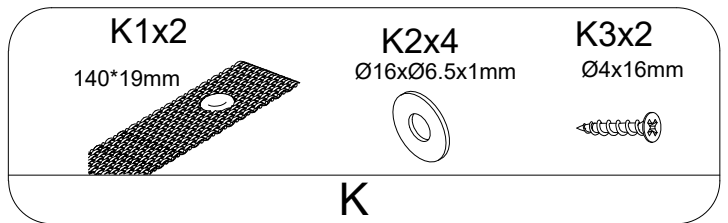
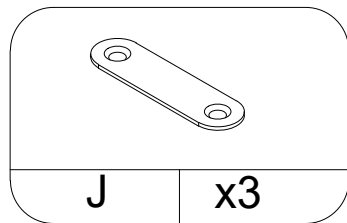
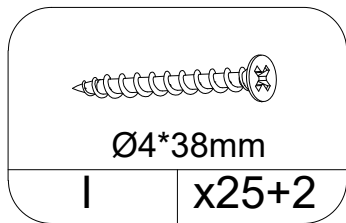
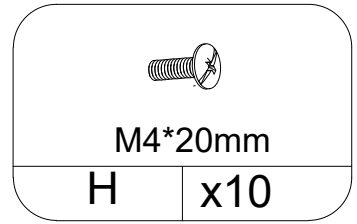
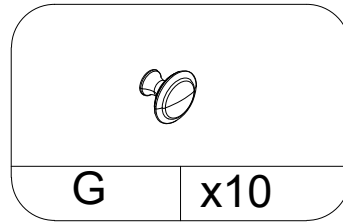
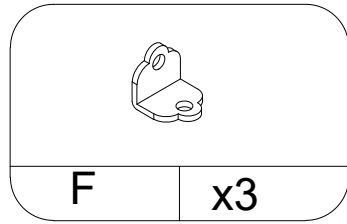
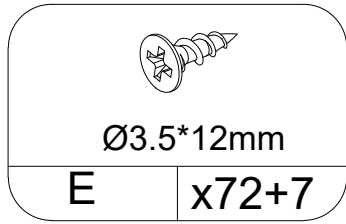
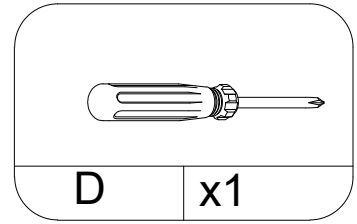
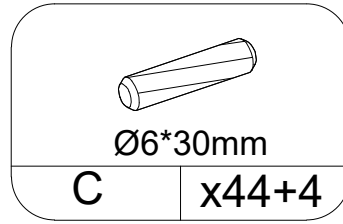
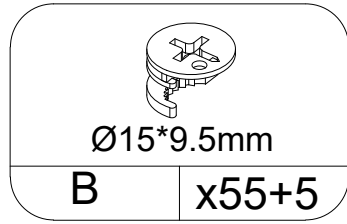
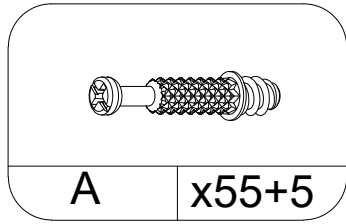

Cam Lock Fastening System

Insert the cam bolt into the hole first, then insert the cam lock and lock it.

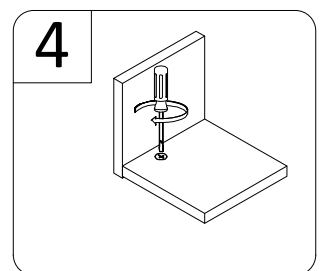
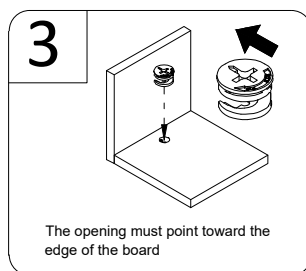
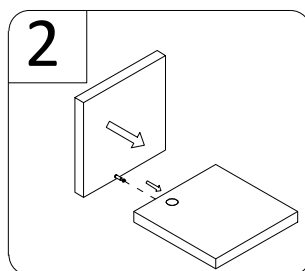
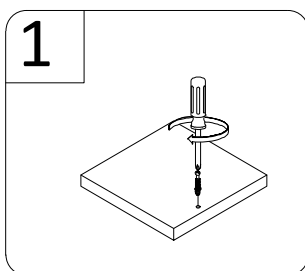

STEP 1

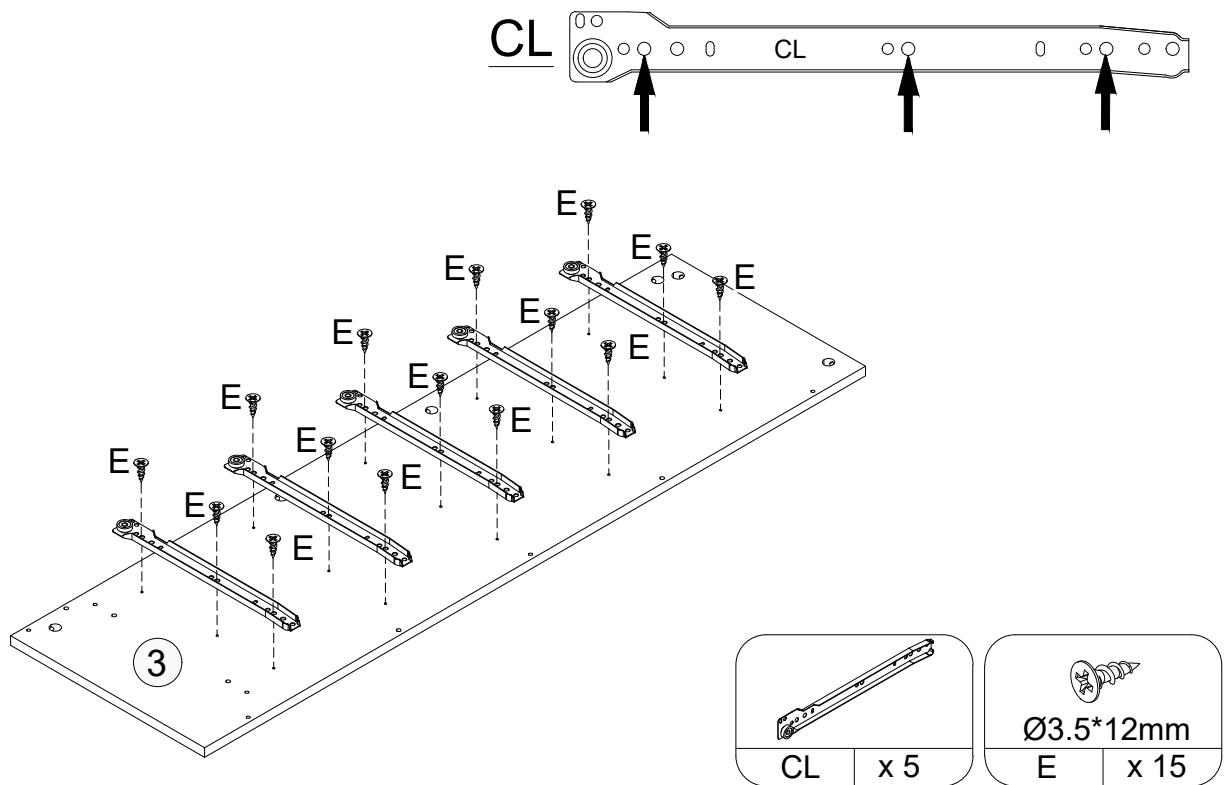

STEP 2

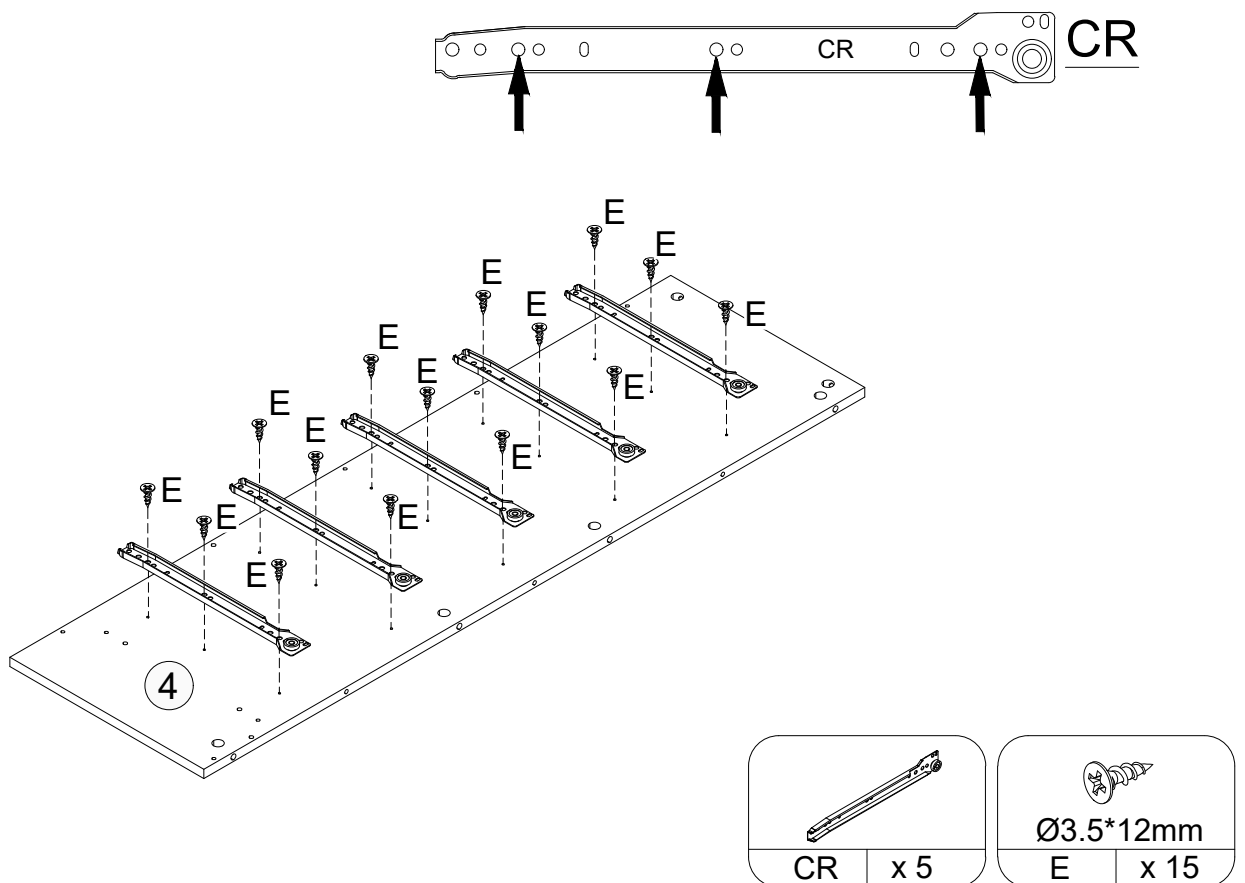

STEP 3

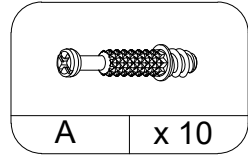
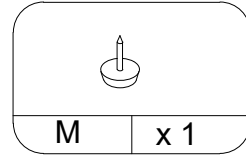
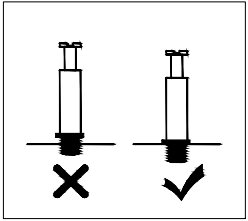
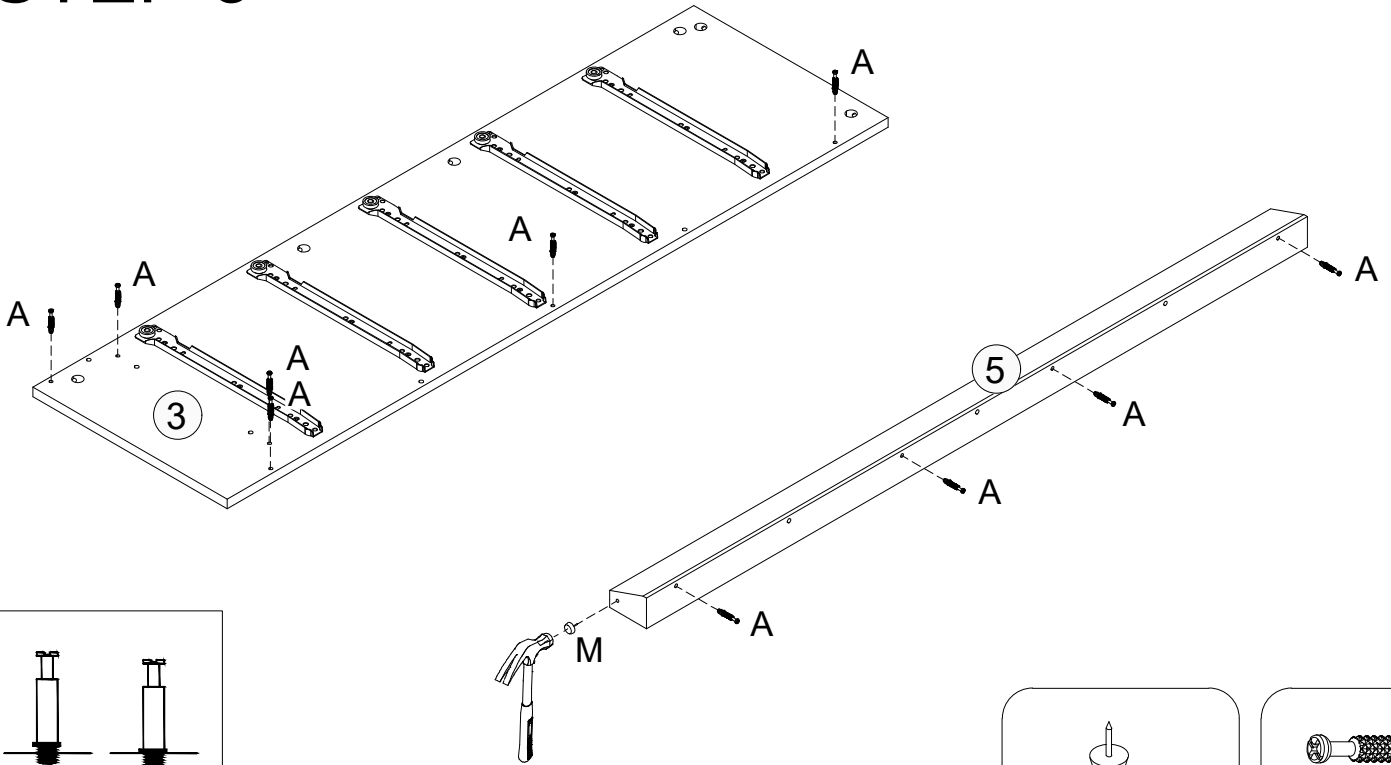

STEP 4

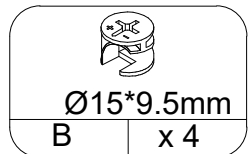
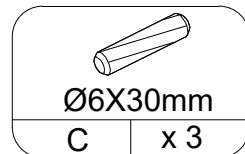
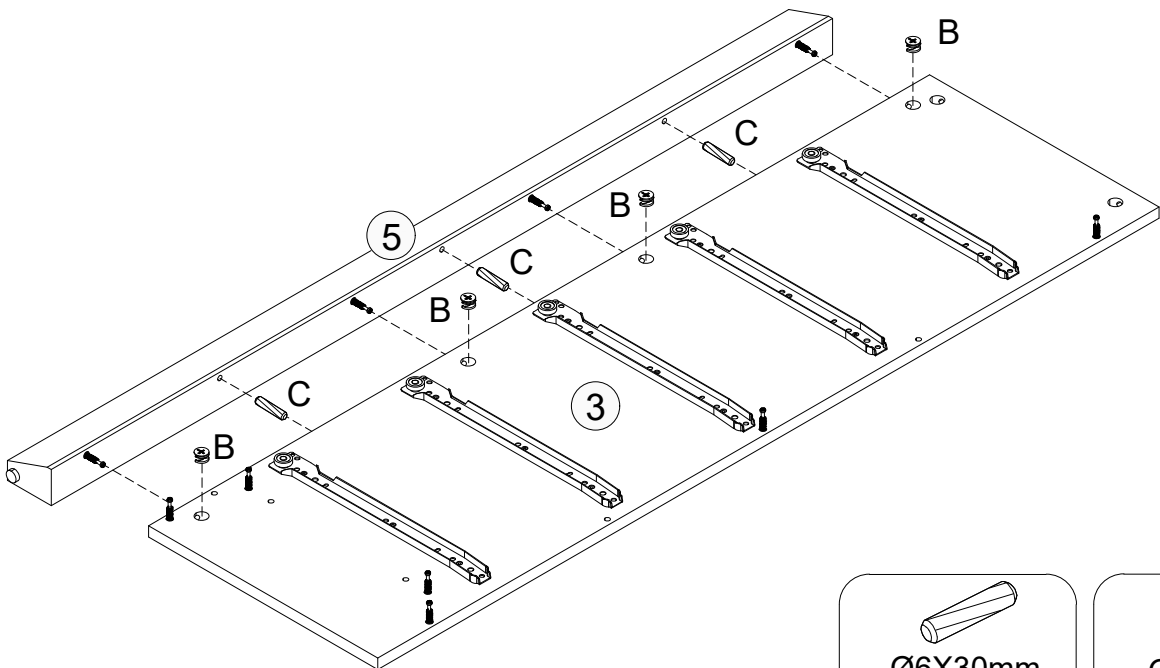
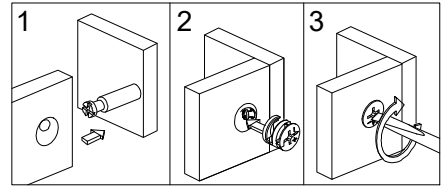

STEP 5

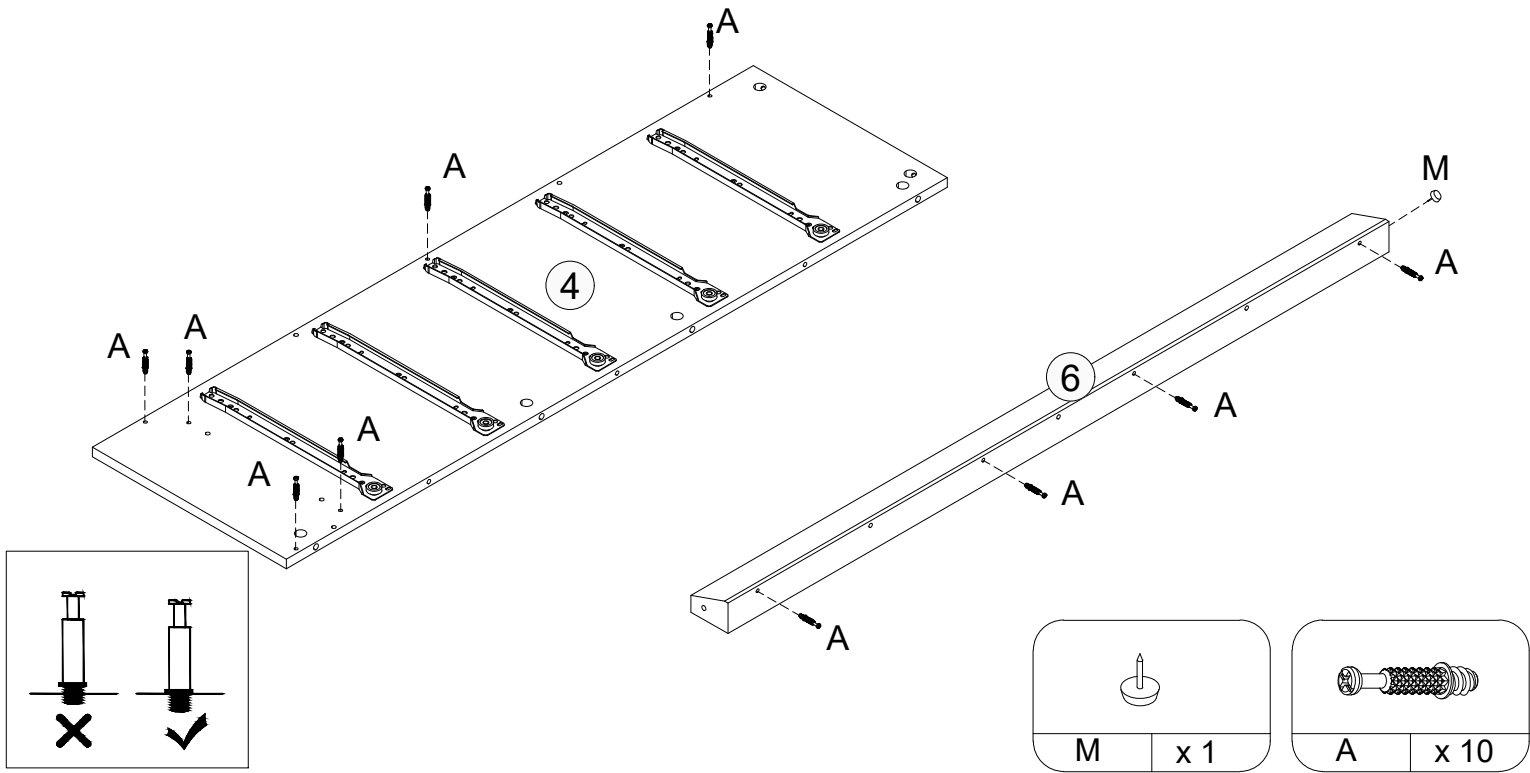

STEP 6

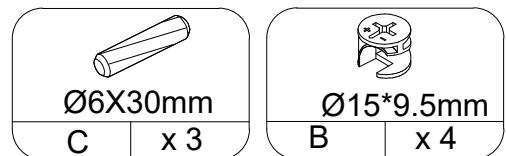
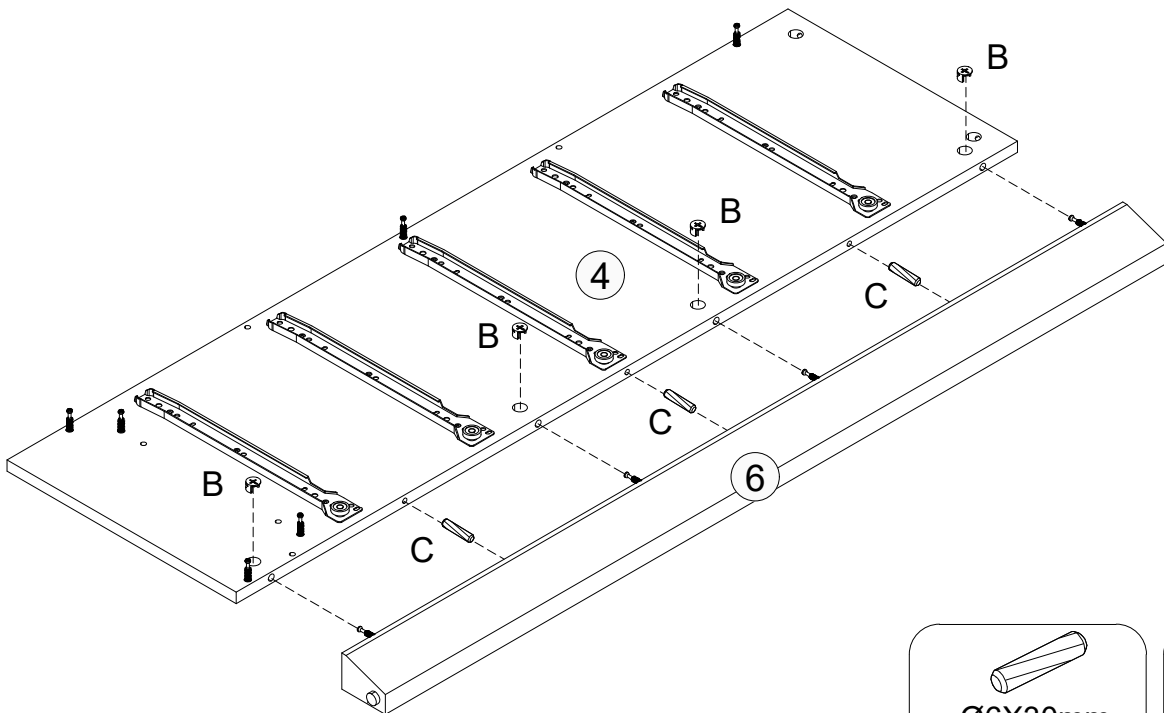
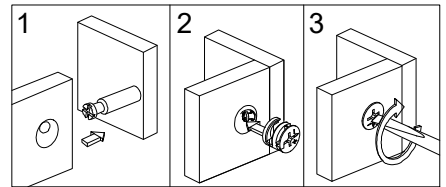

STEP 7

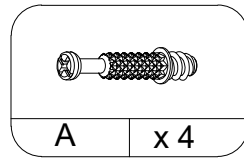
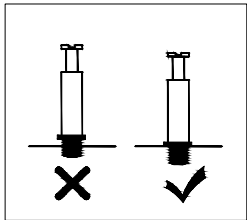
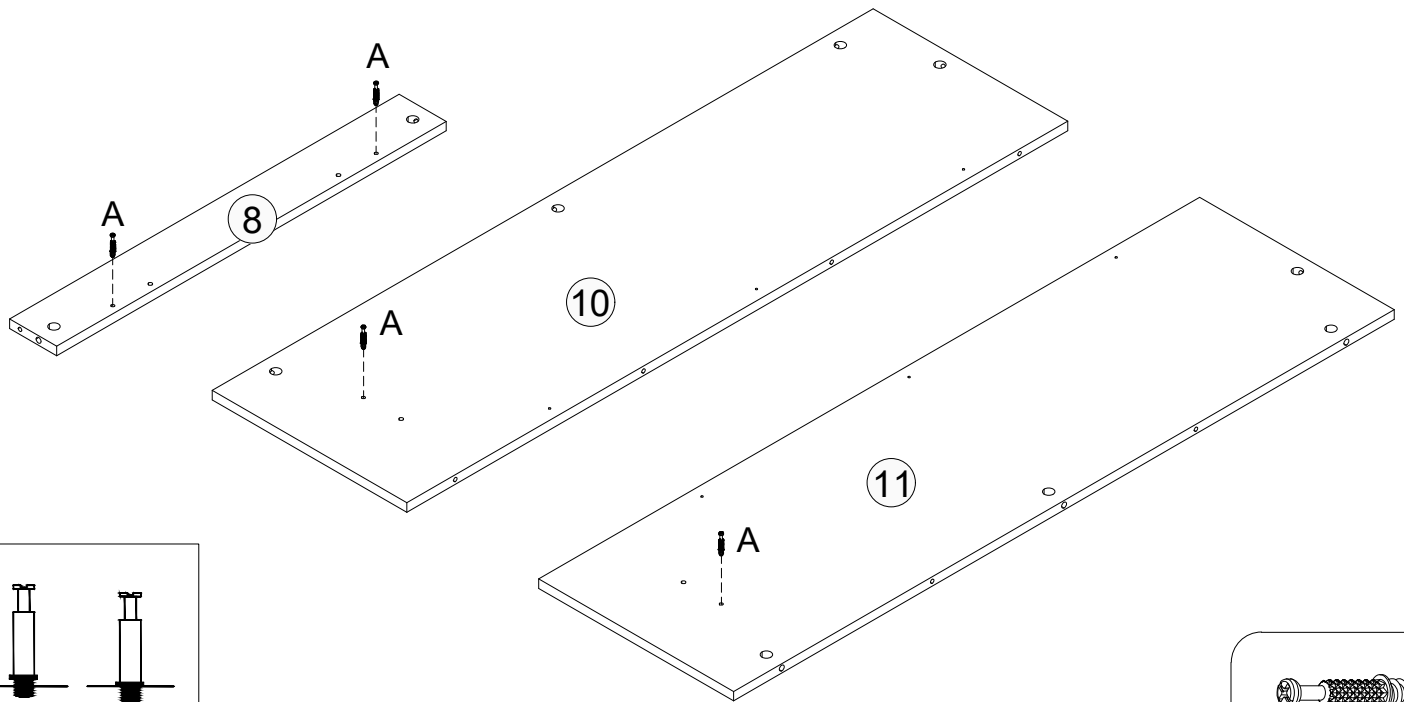



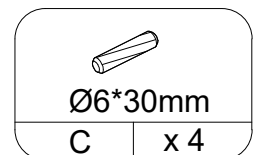
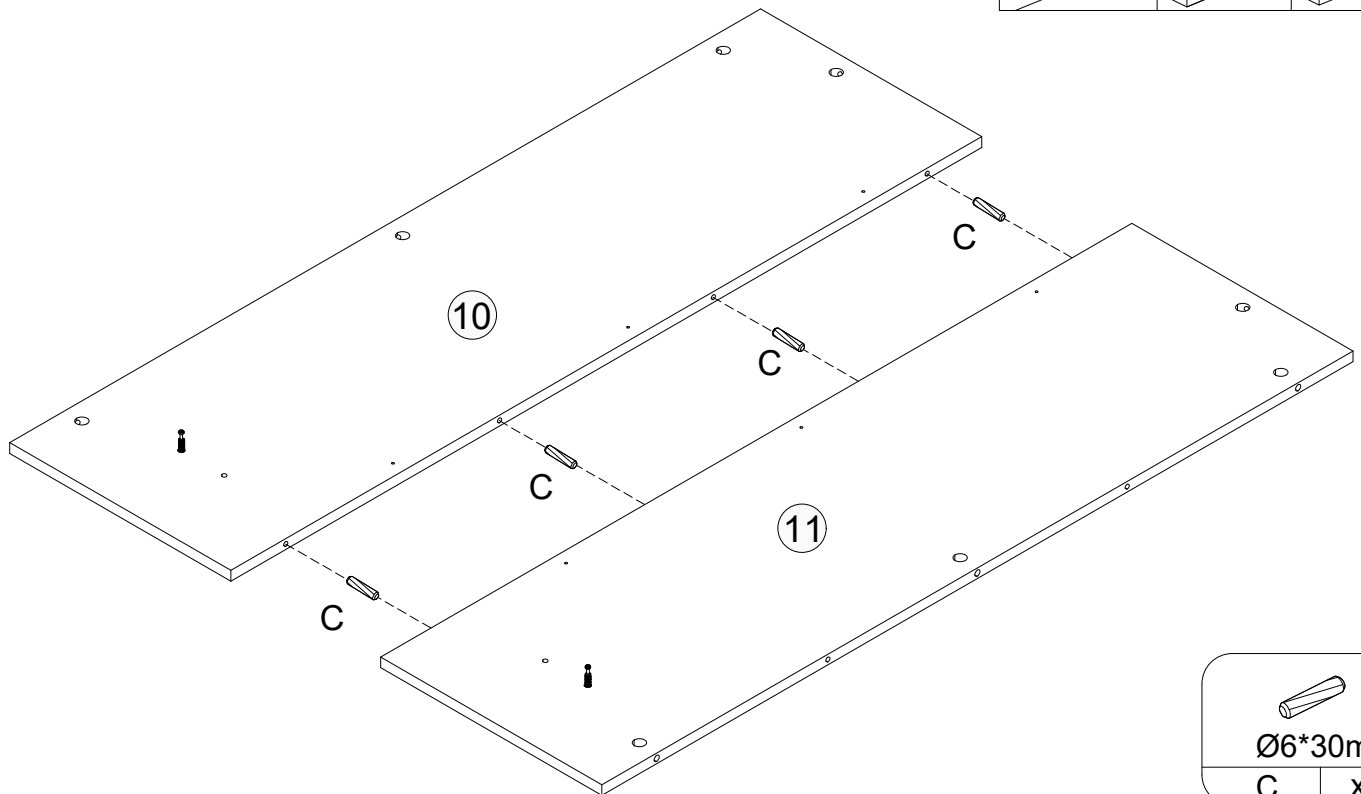
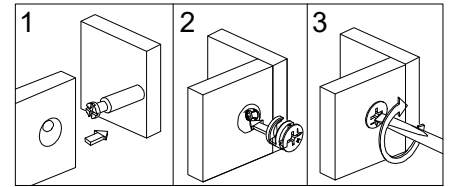

STEP 8

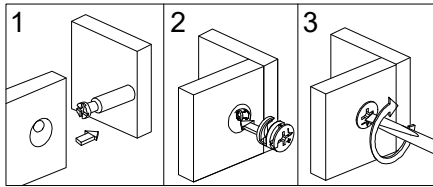
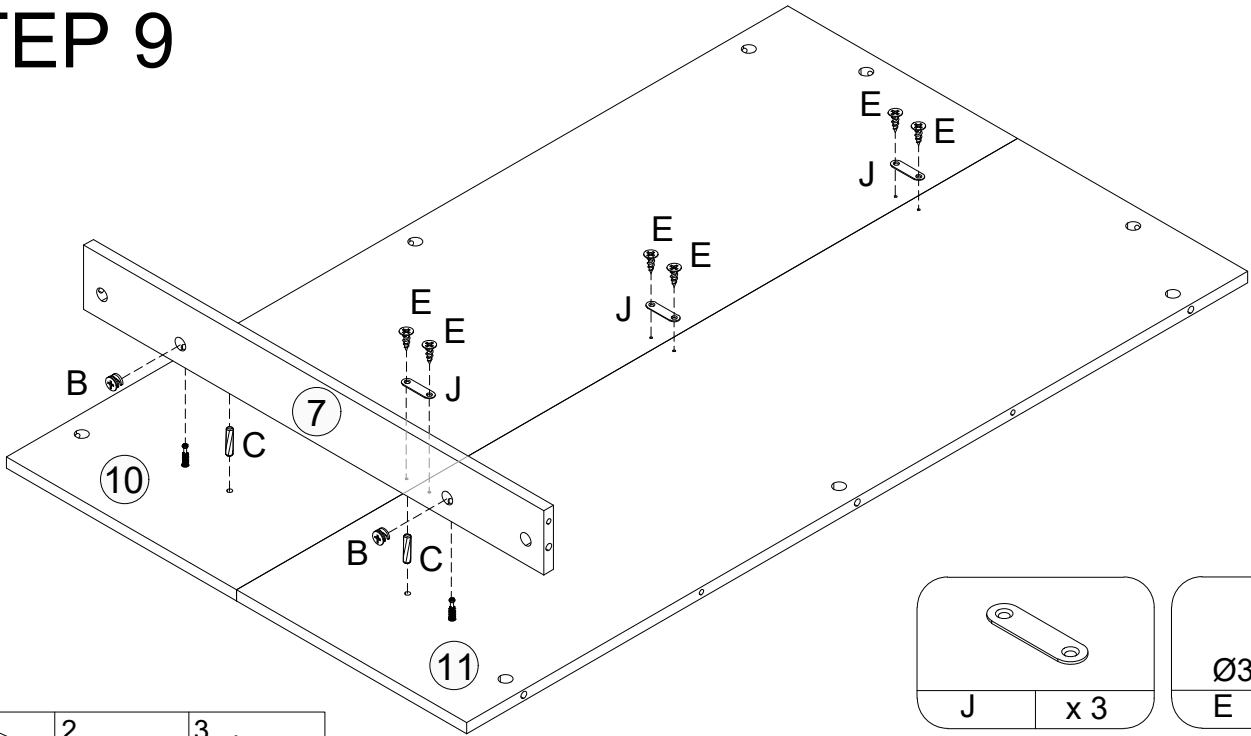

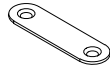

STEP 9

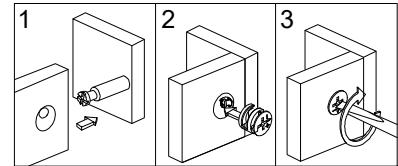
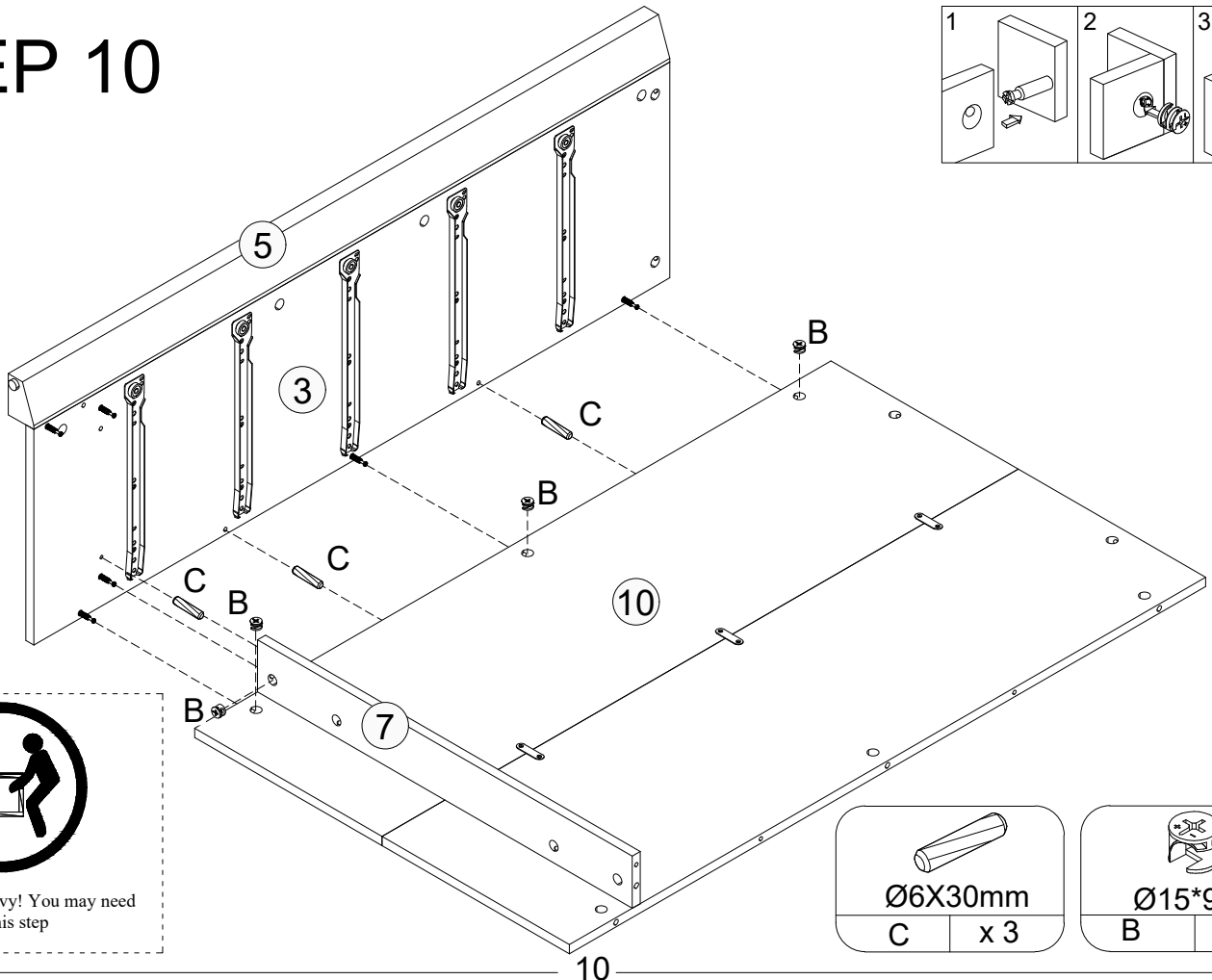

	
J	x 3
Ø3.5*12mm	
E	
x 6	
	
C	x 2
Ø6*30mm	
Ø15*9.5mm	
B	
x 2	

STEP 10



	
C	x 3
Ø6X30mm	
Ø15*9.5mm	
B	
x 4	

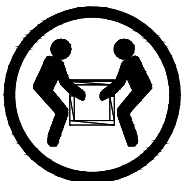

CAUTION: Heavy! You may need assistance with this step

STEP 11

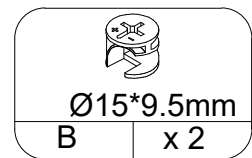
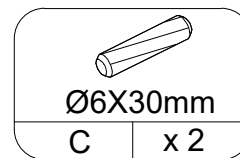
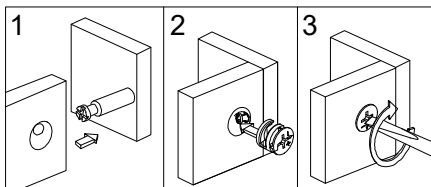
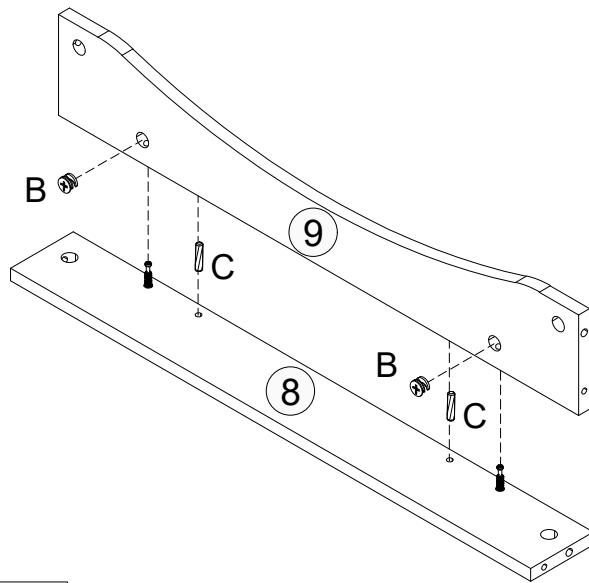

STEP 12

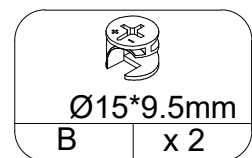
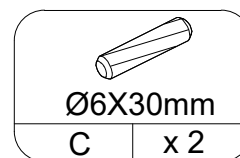
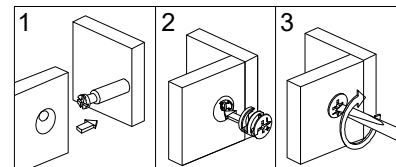
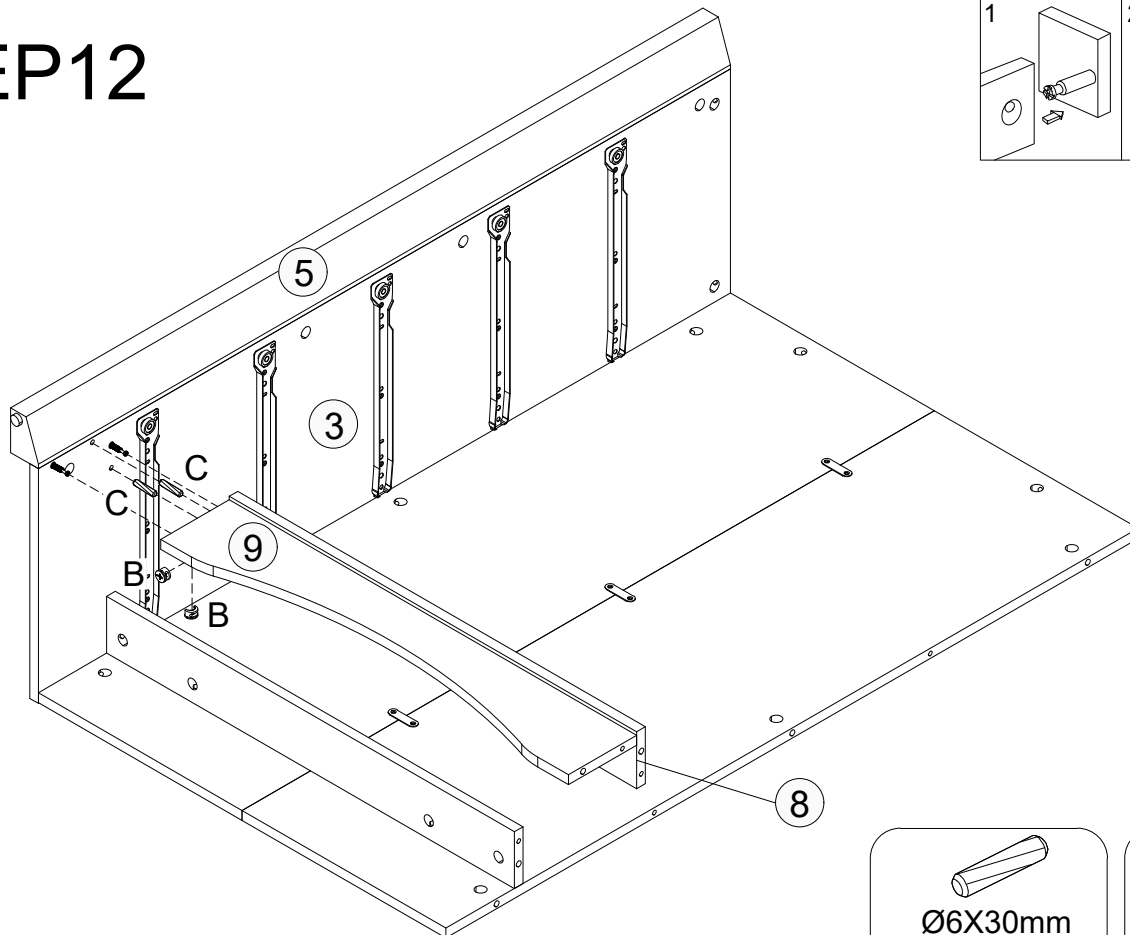

STEP 13

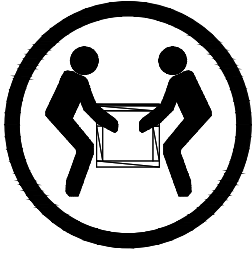

CAUTION: Heavy! You may need assistance with this step

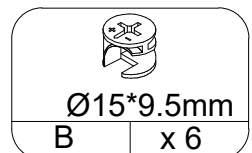
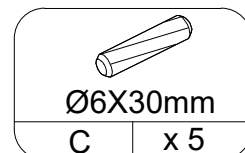
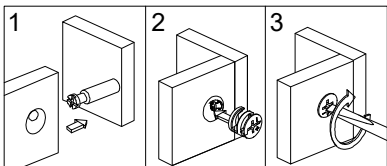
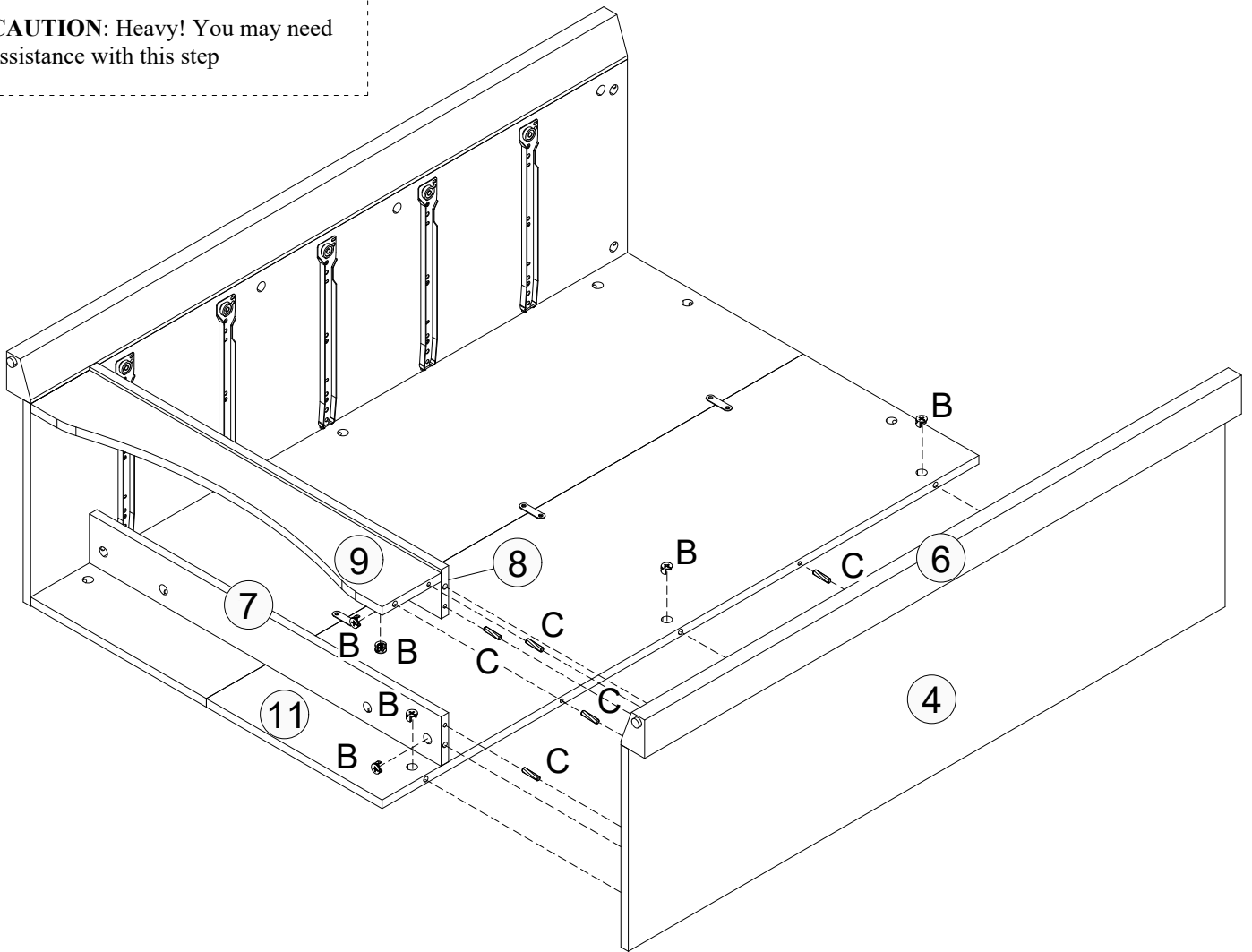

STEP 14

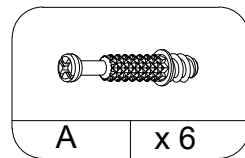
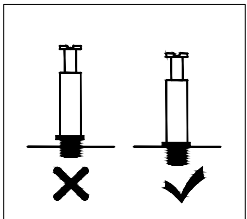
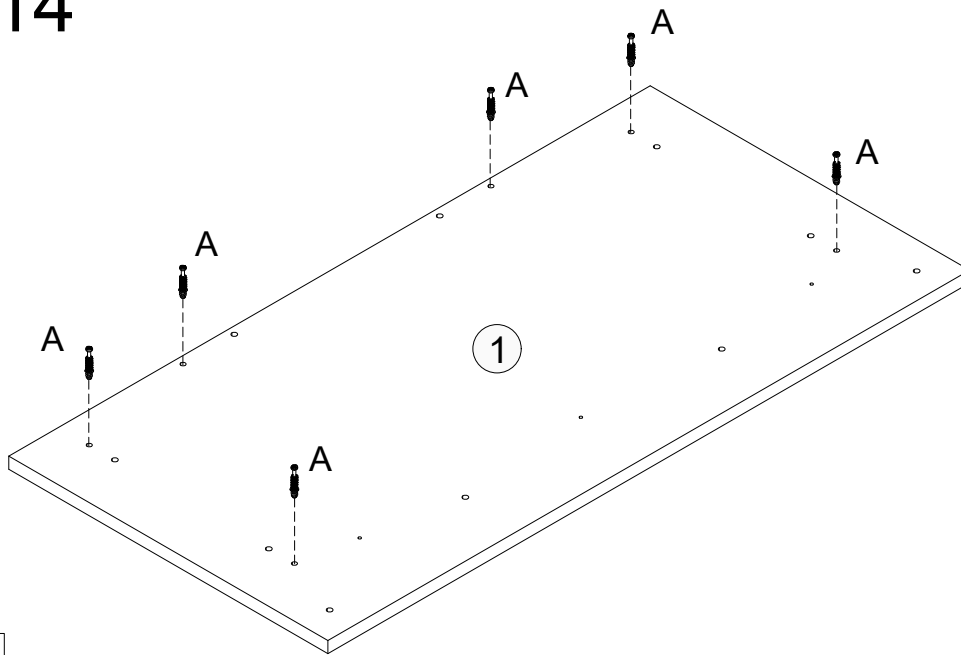

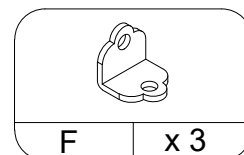
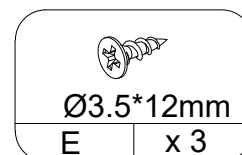
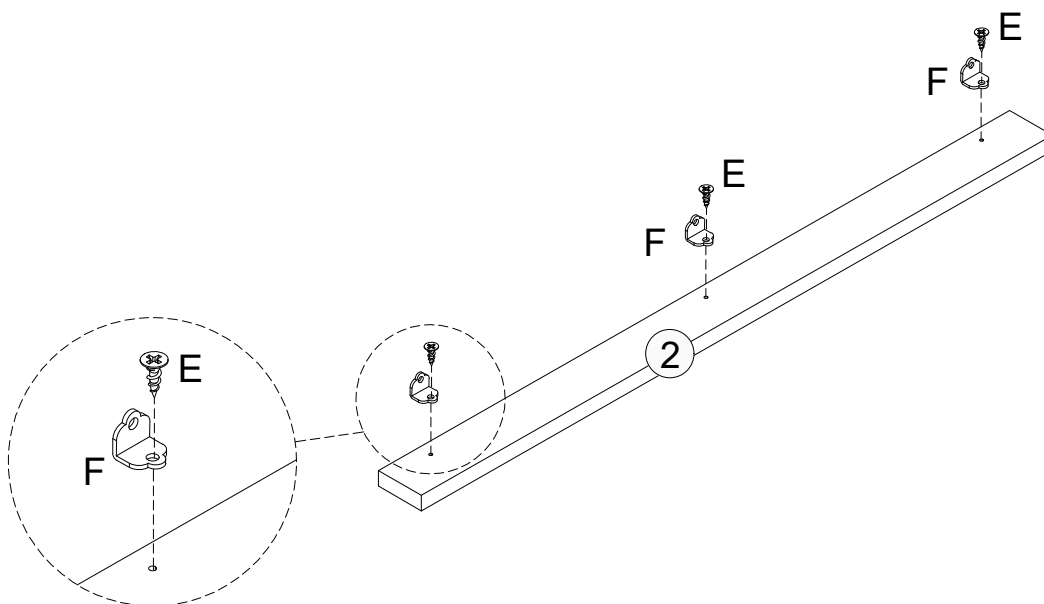

STEP 15

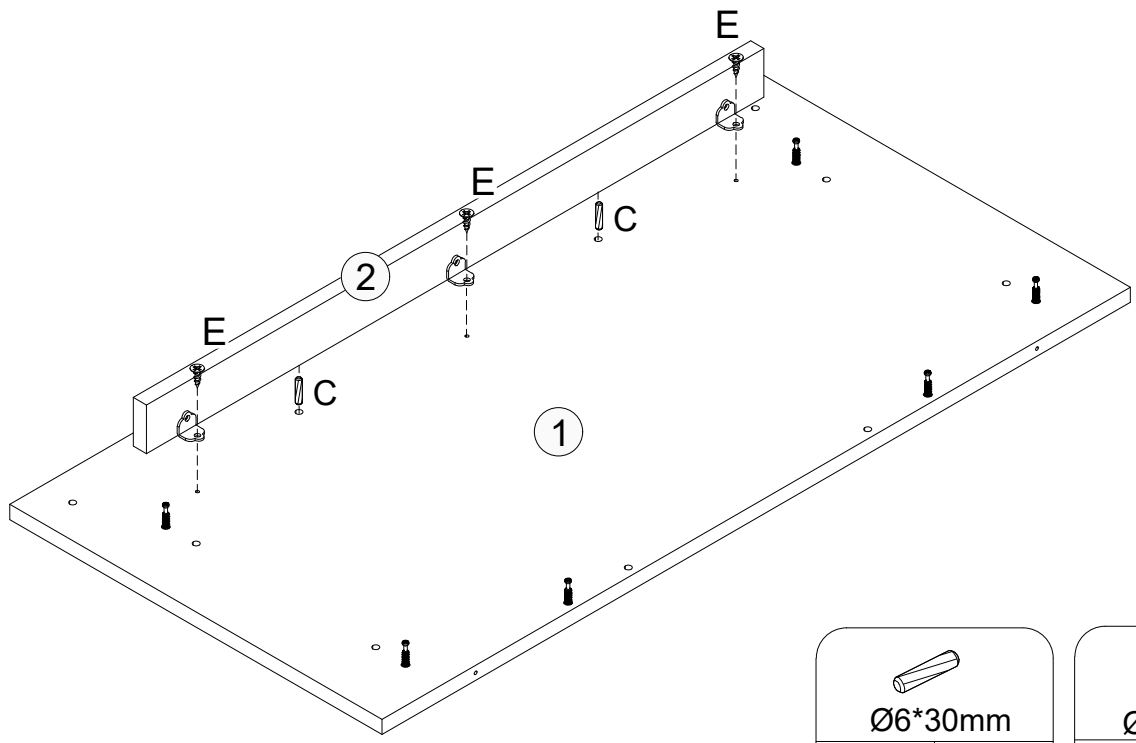

STEP 16





	
Ø6*30mm	
C	x 2

	
Ø3.5*12mm	
E	x 3

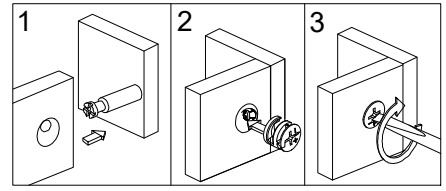
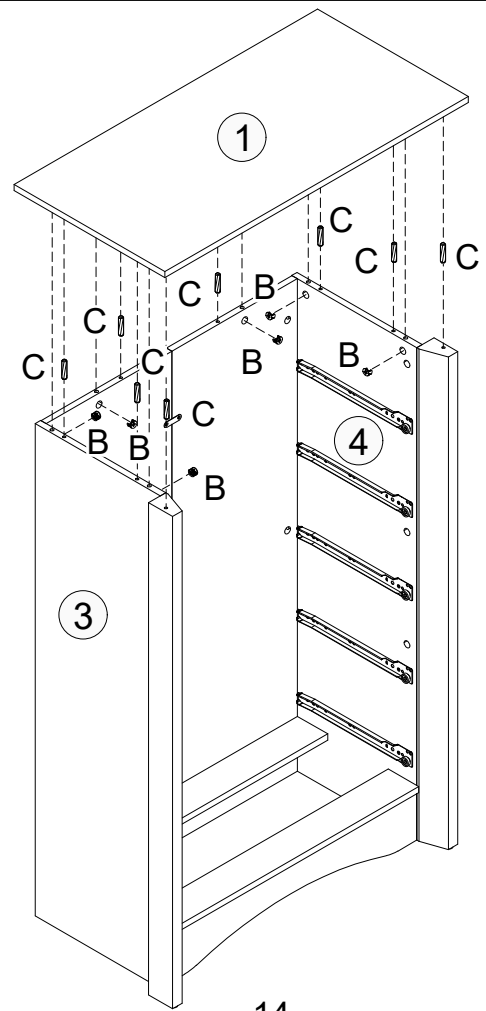
STEP 17



	
Ø6X30mm	
C	x 8

	
Ø15*9.5mm	
B	x 6

STEP 18

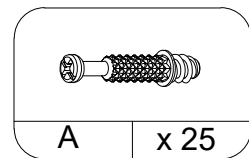
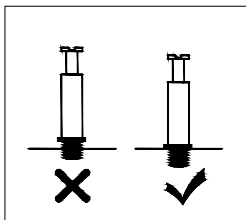
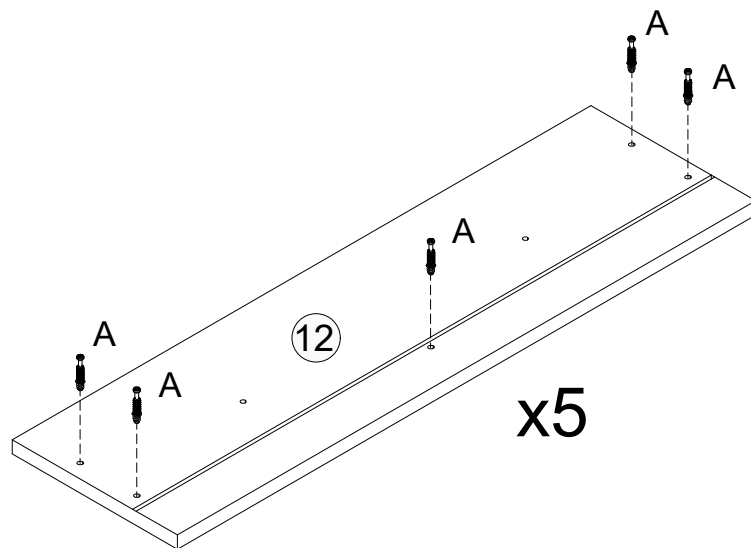

STEP 19

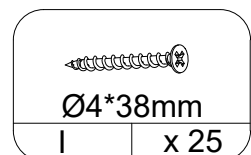
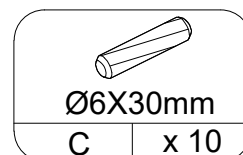
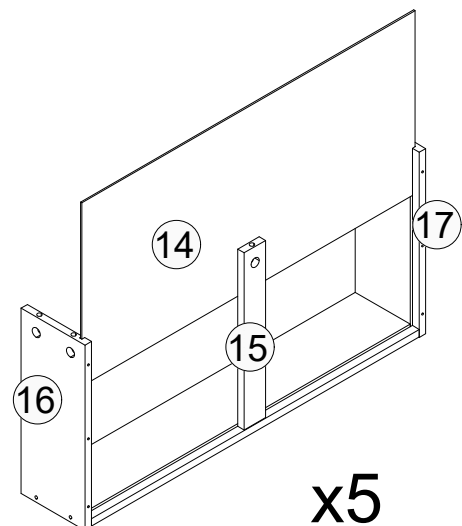
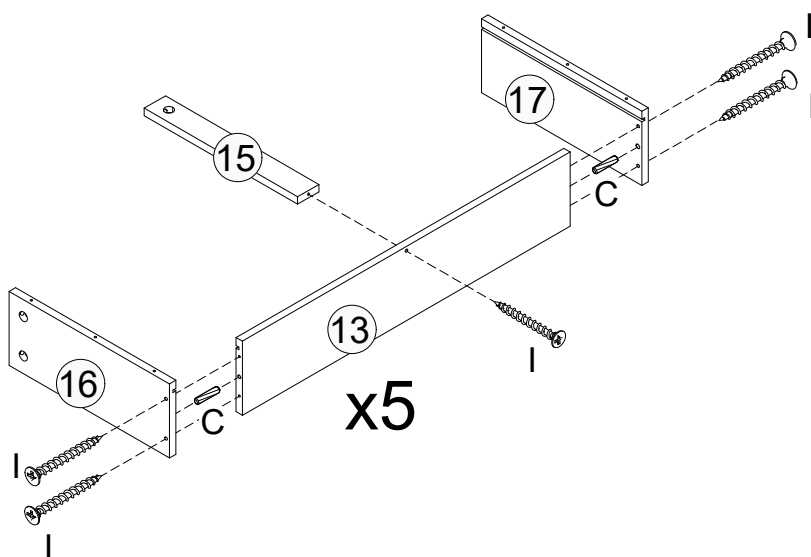

STEP 20

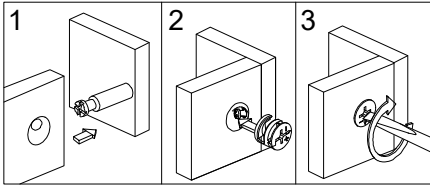
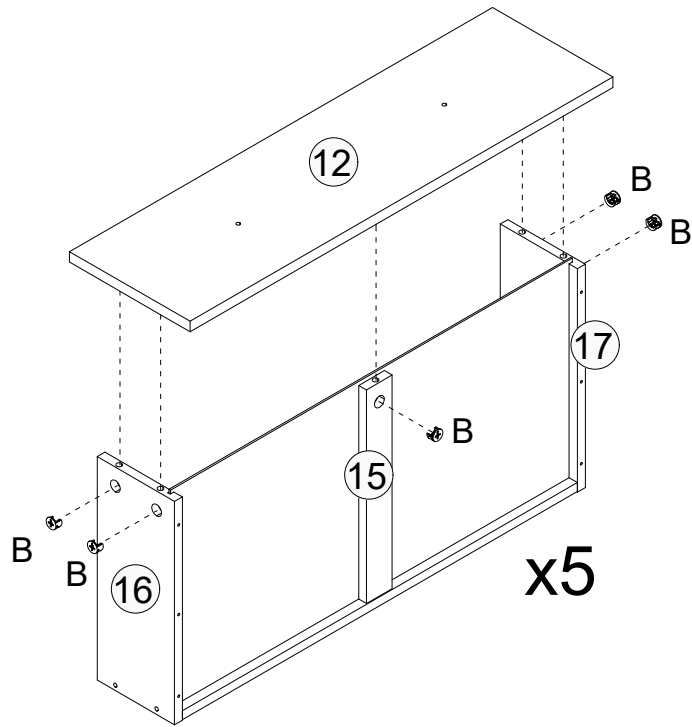

Ø15*9.5mm	
B	x 25

STEP 21

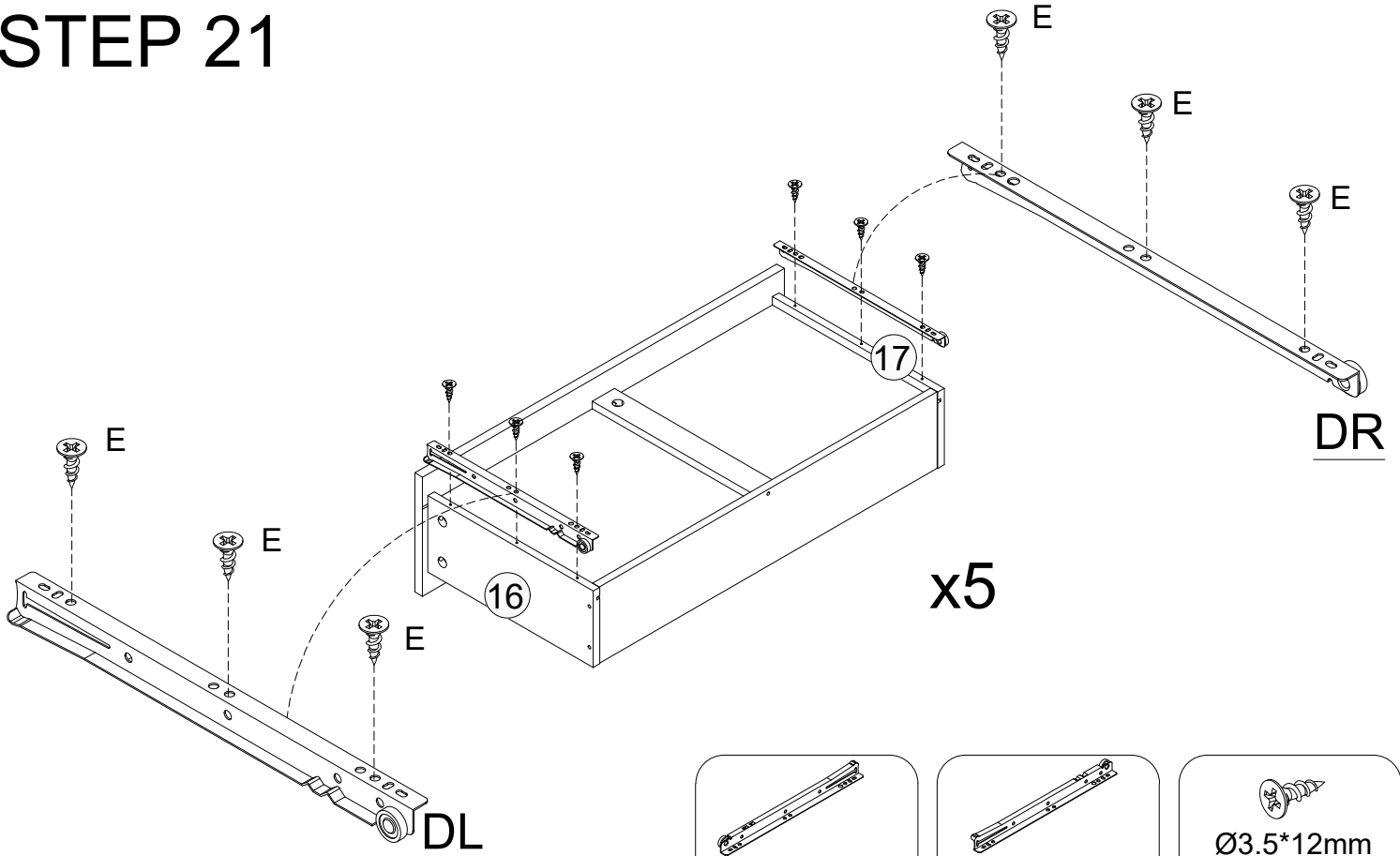

DR	x 5

DL	x 5

Ø3.5*12mm	
E	x 30

STEP 22

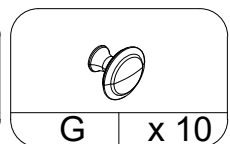
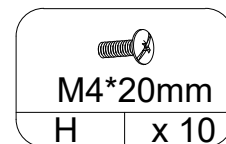
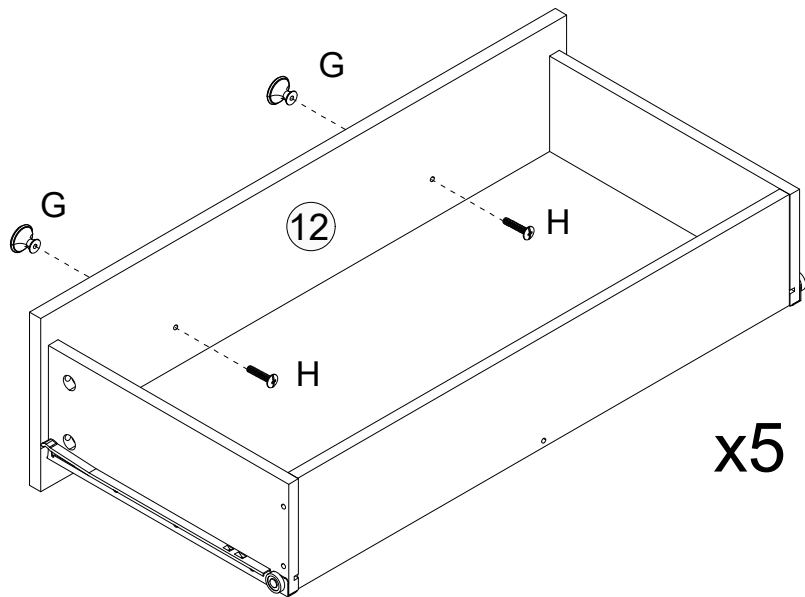

STEP 23

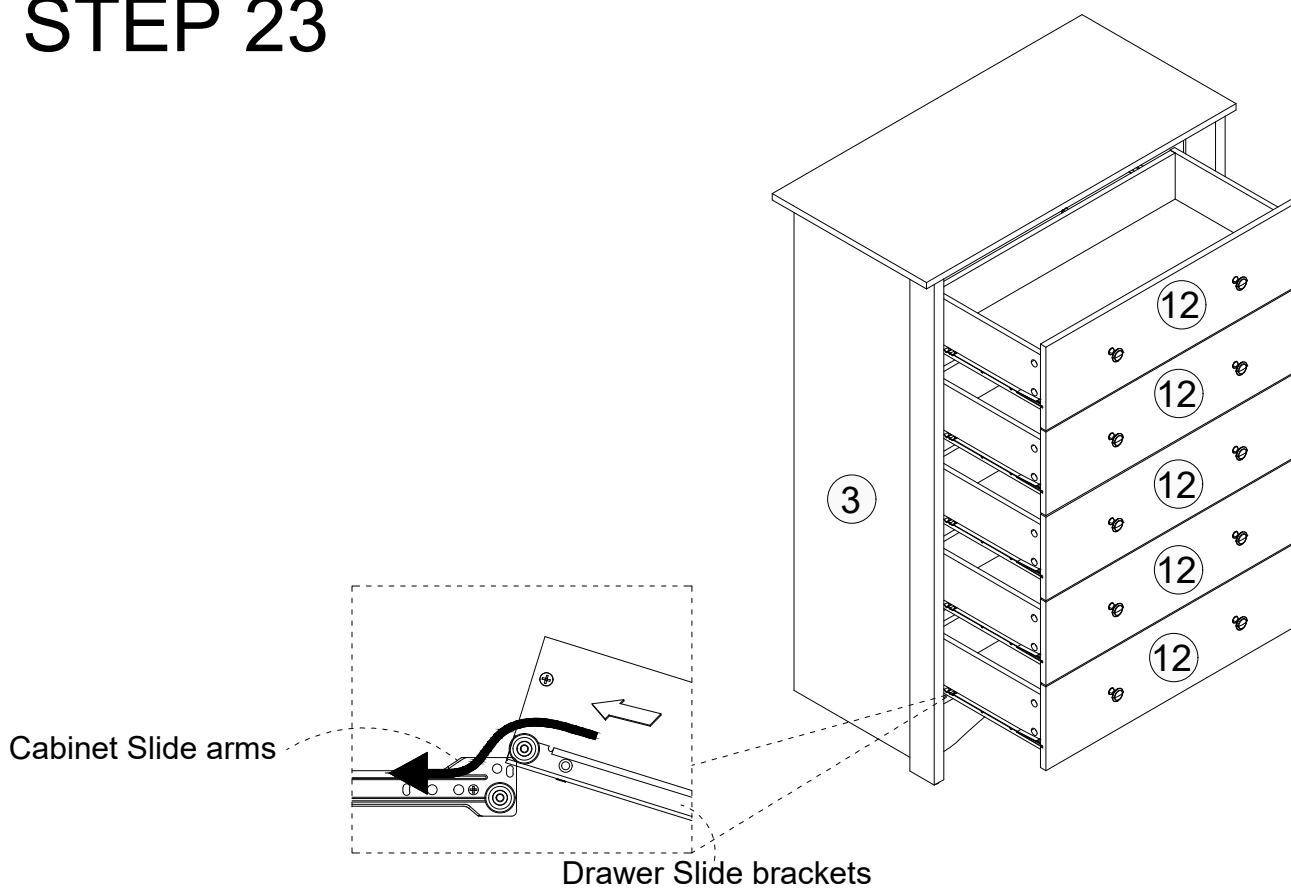

STEP 24

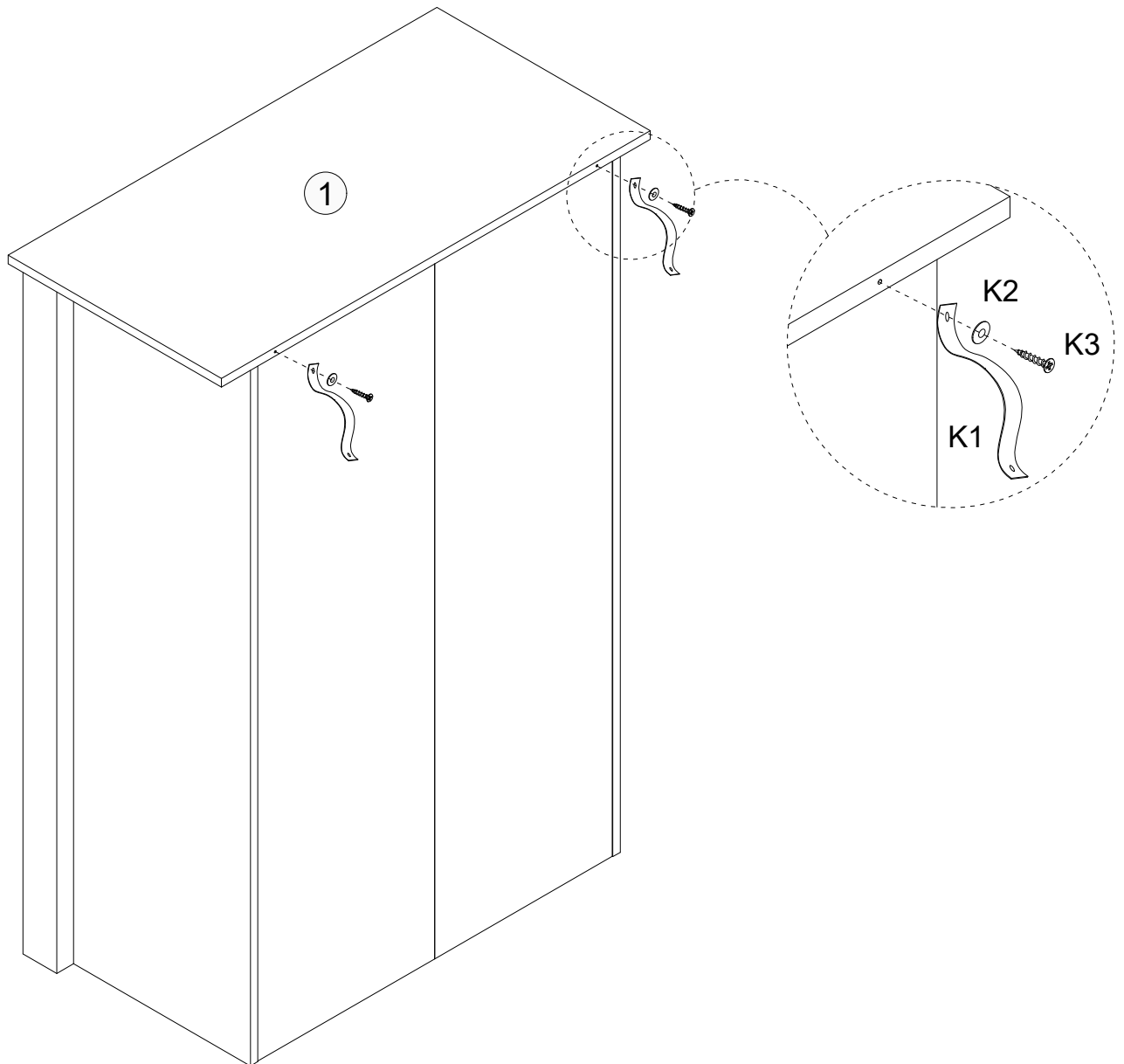

Use screw (K3) and washer (K2) to fix the strap (K1)
follow position of holes on the peice 1.

K1 x 2

K2 x 2

K3 x 2

STEP 25

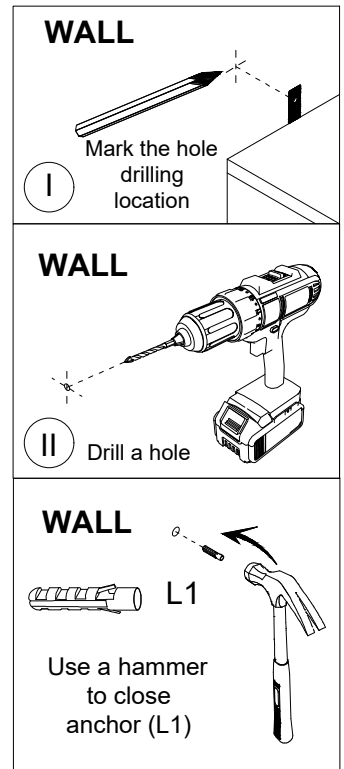
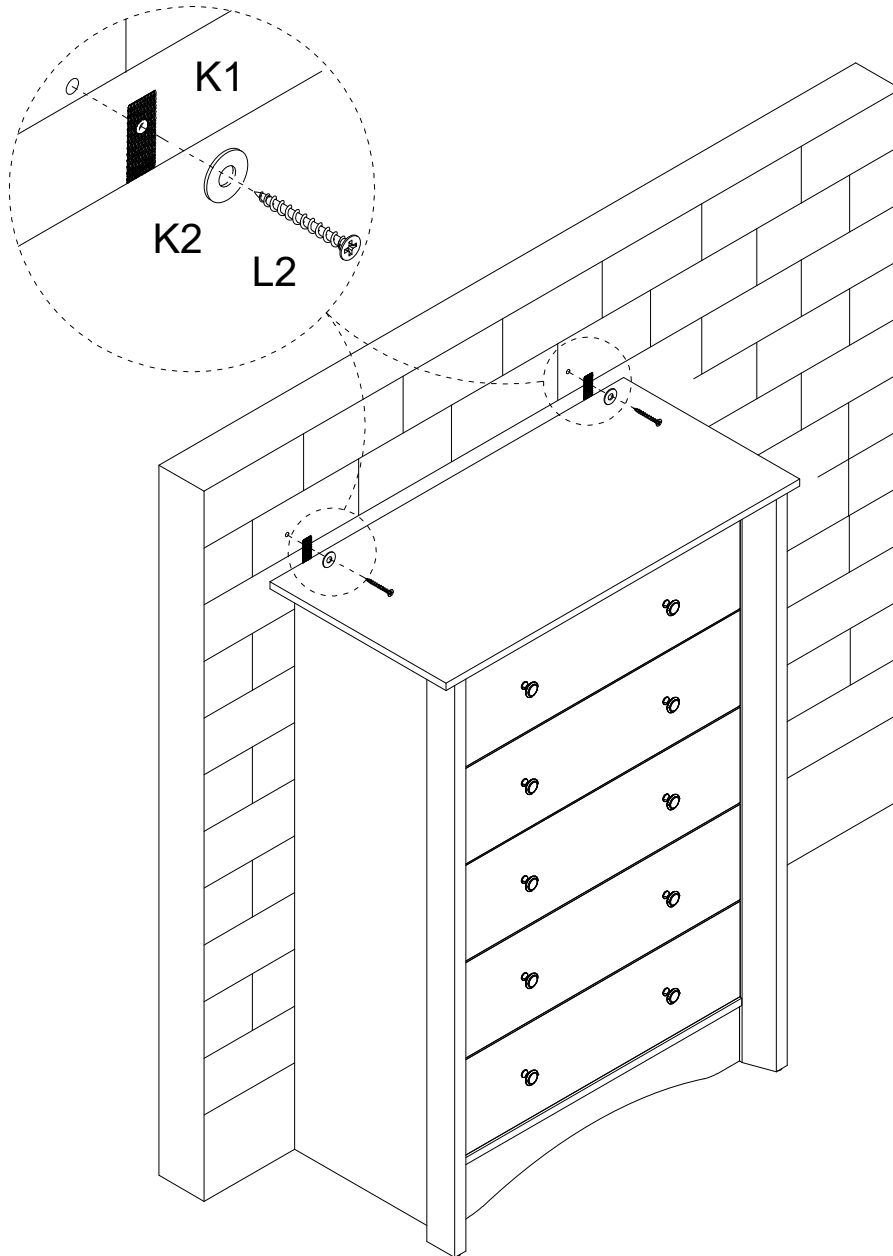

Step 1: determine the location of the anti-overturning on the wall and then mark the position after confirming the product has been balanced.

Step 2: drill the hole and then fixed the anchor (L1) on the wall.

Step 3: use screw (L2) to fix the strap (K1), (K2) on the wall .

L1 x2
L2 x2
K2 x2

FURNITURE CARE AND MAINTENANCE

Medium - Density Fiberboard and Particle board

Thank you for your purchase. We want your item to last as long as possible. To ensure the product gives you years of service, please refer to this care and maintenance guide.



MAINTENANCE

- Tighten all bolts and screws again within the first 2 weeks of assembly
- Check the tightness of all bolts every 2 months, tighten them if necessary



CLEANING

- Clean the surface of the MDF (medium - density fiberboard) or PB (particle board) with a lightly dampened cloth.
- Small amount of mild soap can be used if necessary
- Dry the surface immediately after cleaning.

⚠ DO NOT use bleach or alcohol detergent to clean the surface.

⚠ DO NOT apply wood treatment on parts made with MDF and PB.

Medium - density fiberboard and Particle board will swell and distort when suffer from water damage.

Make sure to dry the furniture immediately after cleaning