

NOTICE

- * Please make sure that you have all parts indicated and they are in good condition before you begin assembly of this item. Refer to part list and hardware list below for guidance.
- * This item should be assembled on a soft surface to prevent scratching the finish during assembly.
- * This item may require periodic tightening.
- * If you are having difficulty, our friendly Customer Care team is always here to help. Please email customersupport@safavieh.com





PREPARATION

- * Before beginning assembly of product, make sure all parts are present. Compare parts with part contents list and hardware contents list.
- * If any part is missing or damaged, do not attempt to assemble the product.
- * Estimated Assembly Time: 10 minutes.
- * Tools Required for Assembly (included): Allen Wrench.

CARE AND MAINTENANCE

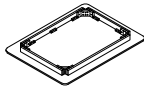
WOOD CARE: Adhesive felt pads should always be applied to areas of furniture which make direct contact with flooring, said application will prevent damage to the furniture and or surfaces on which the furniture lies. Objects placed on articles of furniture should rest on non abrasive material as to prevent damage to the wood finish. Wipe up spills immediately and avoid common hazards such as hot dishes, harsh solvents and abrasives. Cleaning should be done with a soft lint free cotton cloth dampened with water or furniture polish.

Part List and Hardware List

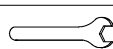
PIECE	DESCRIPTION	PICTURE	QTY
A	TABLE TOP		1x
B	TABLE LEGS		4x
HW1	Flat Washer	 5/16"*19mm	8x
HW2	Spring Washer	 5/16"*13mm	8x
HW3	Nut	 5/16"-18*0.25"	8x
HW4	Allen Wrench	 90x13mm	1x

SAFAVIEH

C O U T U R E

Model# SFV2181

Product Dimensions: 48"L x36"W x30.25"H

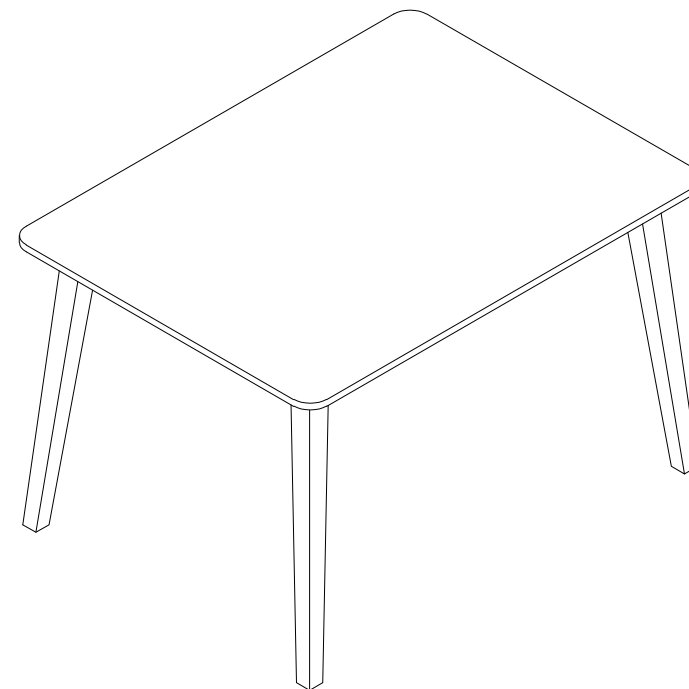

Weight capacity: 100lbs
WARNING : DO NOT STAND ON PRODUCT
WARNING : DO NOT OVER TORQUE BOLTS

PREPARATION

- * Before beginning assembly of product, make sure all parts are present. Compare parts with part contents list and hardware contents list.
- * If any part is missing or damaged, do not attempt to assemble the product.
- * Estimated Assembly Time: 10 minutes.
- * Tools Required for Assembly (included): Allen Wrench.
- * If you are having difficulty, our friendly Customer Care team is always here to help. Please email customersupport@safavieh.com

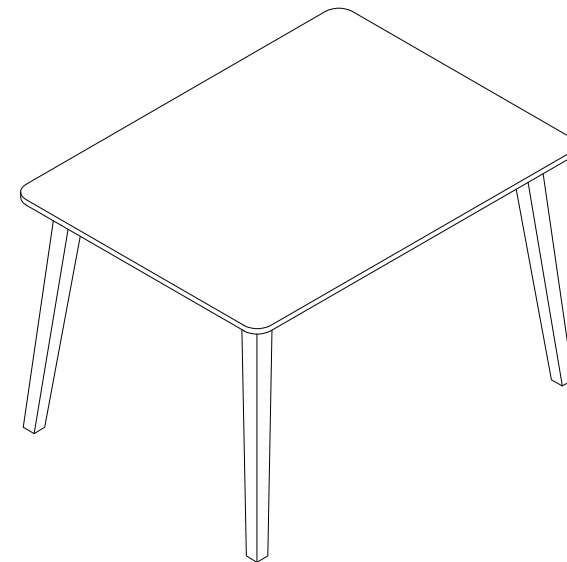
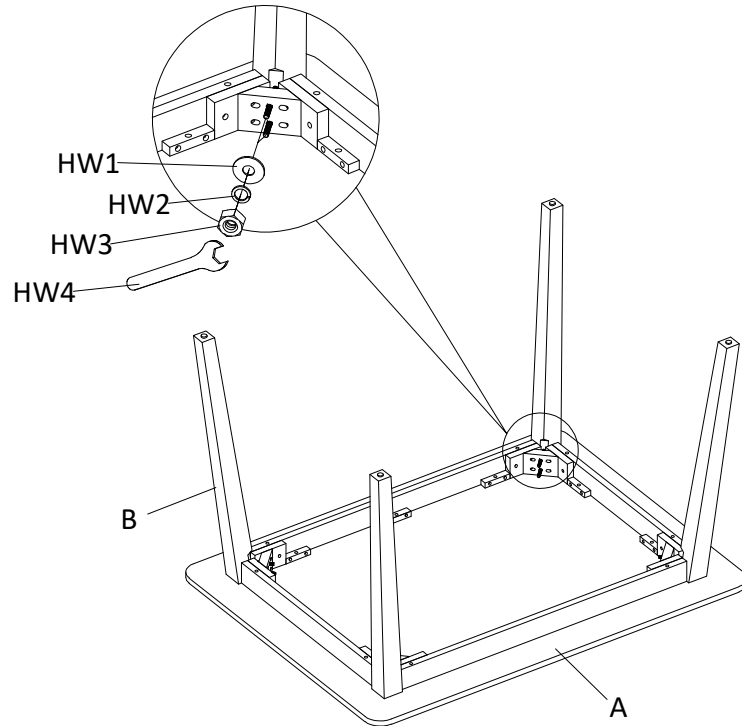

* Do not fully tighten the bolts until the product is assembled.

* Make sure all bolts are fully tightened.

STEP 1

PLACE THE TABLE TOP (A) UPSIDE DOWN ON A SOFT SURFACE. INSERT THE BOLT ON THE TABLE LEG (B) INTO THE HOLE ON THE APRON OF TABLE TOP (A). INSERT THE FLAT WASHER (HW1), SPRING WASHER (HW2), NUT (HW3) INTO THE BOLT IN SEQUENCE, AND SCREW-IN THE NUT (HW3) BY USING ALLEN WRENCH (HW4), AS SHOWN IN THE FIGURE.

STEP 2

TURN THE TABLE UPRIGHT. PRODUCT IS NOW READY FOR USE.