

Right assembly - p.3
Assemblage droit - p.3
Ensamblaje derecho - p.3

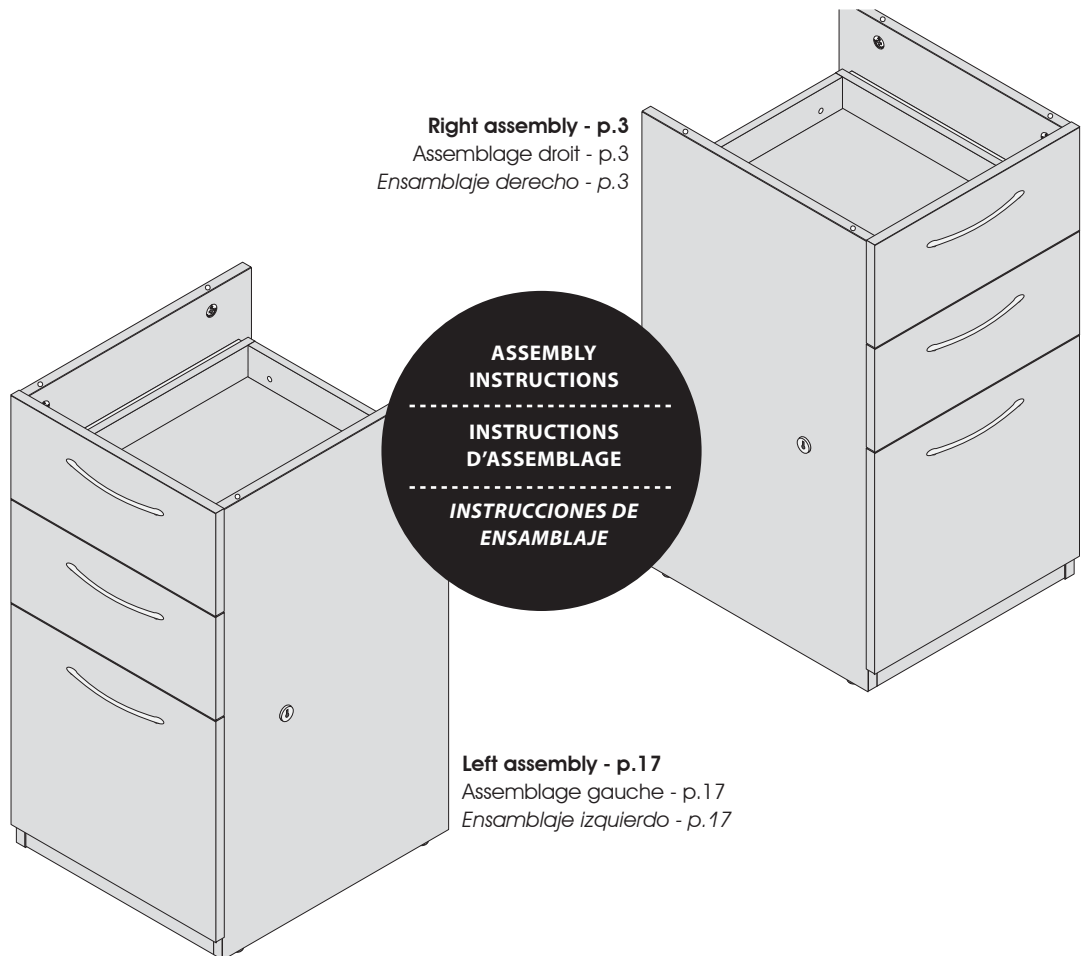

**ASSEMBLY
INSTRUCTIONS**

**INSTRUCTIONS
D'ASSEMBLAGE**

**INSTRUCCIONES DE
ENSAMBLAJE**

Left assembly - p.17
Assemblage gauche - p.17
Ensamblaje izquierdo - p.17

PARTS / PIÈCES / PIEZAS

CODE / CÓDIGO	QTY / QTÉ / CANT.	CODE / CÓDIGO	QTY / QTÉ / CANT.	CODE / CÓDIGO	QTY / QTÉ / CANT.	CODE / CÓDIGO	QTY / QTÉ / CANT.
	4		2		2		1
	4		1		1	bottom / fond / fondo 15 3/8" x 12 7/16" (391 mm x 316 mm)	3
	2		1		1		



two people are required to assemble and move this model.
deux personnes sont requises pour assembler et déplacer ce modèle.
se necesitan dos personas para ensamblar y desplazar este mueble.









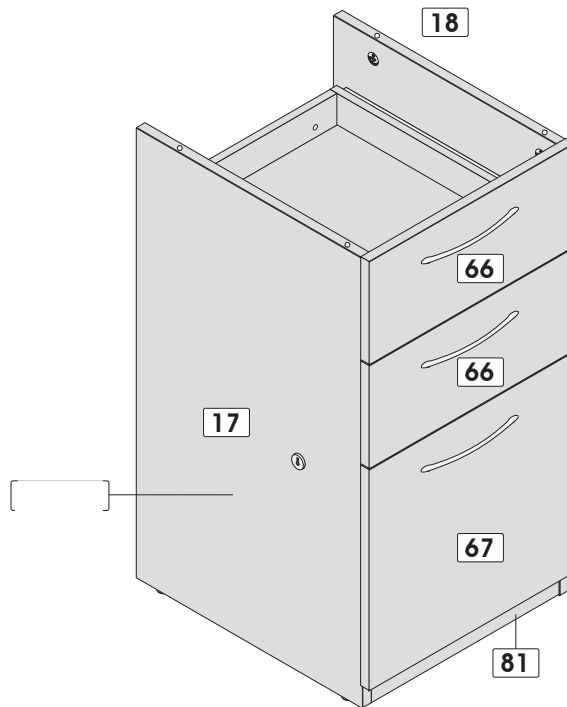







the use of electric tools must be made with vigilance.
l'utilisation d'outils électriques doit être faite avec vigilance.
las herramientas eléctricas deben utilizarse con sumo cuidado.

tools required
outils requis
herramientas necesarias

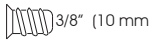
1/4" (7 mm)

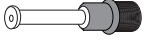
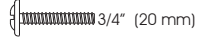

HARDWARES / QUINCAILLERIES / QUINCALLAS

CODE / CÓDIGO	QTY / QTÉ / CANT.	CODE / CÓDIGO	QTY / QTÉ / CANT.	CODE / CÓDIGO	QTY / QTÉ / CANT.	CODE / CÓDIGO	QTY / QTÉ / CANT.
	1	 16 1/8" (411 mm)	2		3	 1" (25 mm)	25
runners 406 mm (16") coulisseaux 406 mm correderas 406 mm	3	-03 	12		1		
	2	H- 	4	 3/8" (10 mm)	18		
	6	H- 	8	 3/4" (20 mm)	12		
 11 7/8" (302 mm)	2	 1" (25 mm)	4	 1/2" (13 mm)	24		

REAL SIZE / GRANDEUR RÉELLE / TAMAÑO REAL

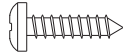
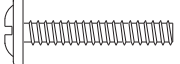
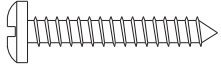
CODE / CÓDIGO	QTY / QTÉ / CANT.	CODE / CÓDIGO	QTY / QTÉ / CANT.
 3/8" (10 mm)	18	 1/2" (13 mm)	24
 3/4" (20 mm)	12	 1" (25 mm)	25

IMPORTANT NOTICE / NOTE IMPORTANTE / NOTA IMPORTANTE

Group together all the hardware required for each step as the construction of your piece of furniture is progressing.

Regroupez toutes les quincailleries requises pour chaque étape de façon à vous assurer de tout installer au bon moment.

Reúna todas las quincallas necesarias para cada una de las etapas de montaje, para asegurar una correcta instalación en el momento adecuado.

▶ IMPORTANT NOTICE / NOTE IMPORTANTE / NOTA IMPORTANTE

Duly complete the self-adhesive sticker. / Assurez-vous de bien remplir l'autocollant. / Asegúrese de completar correctamente la etiqueta.

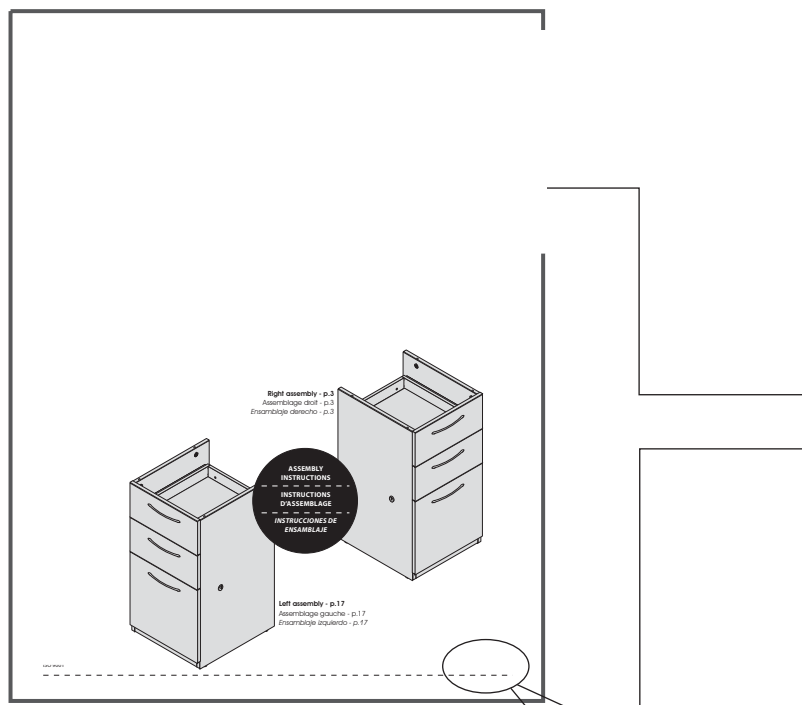

Important/Importante

Please retain the self-adhesive sticker which you will install at step 11 of the instruction manual.

Conservez l'autocollant qui sera collé seulement à l'étape 11 du feuillet d'instructions.

Conserve la etiqueta que será pegada sólo en la etapas 11 de la hoja de instrucciones.

▶ IMPORTANT NOTICE / NOTE IMPORTANTE / NOTA IMPORTANTE

Main hardware system / Système de quincaillerie principal / Sistema principal de quincalla

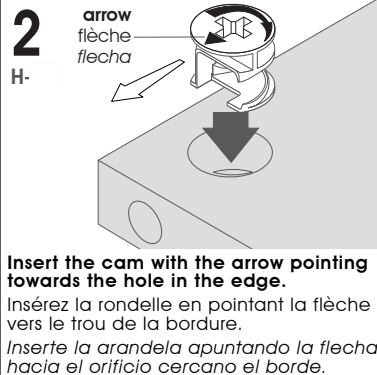
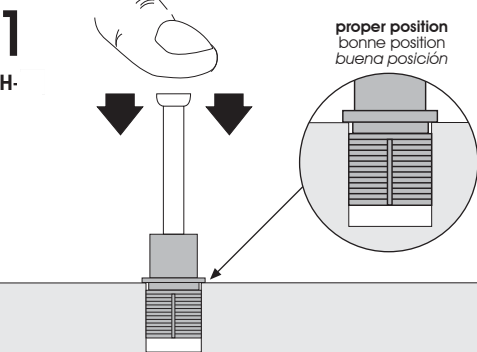



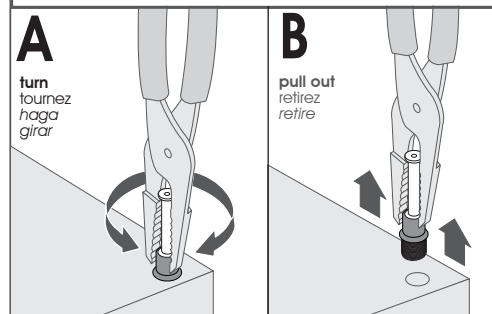

If needed / En cas de nécessité
En caso de necesidad

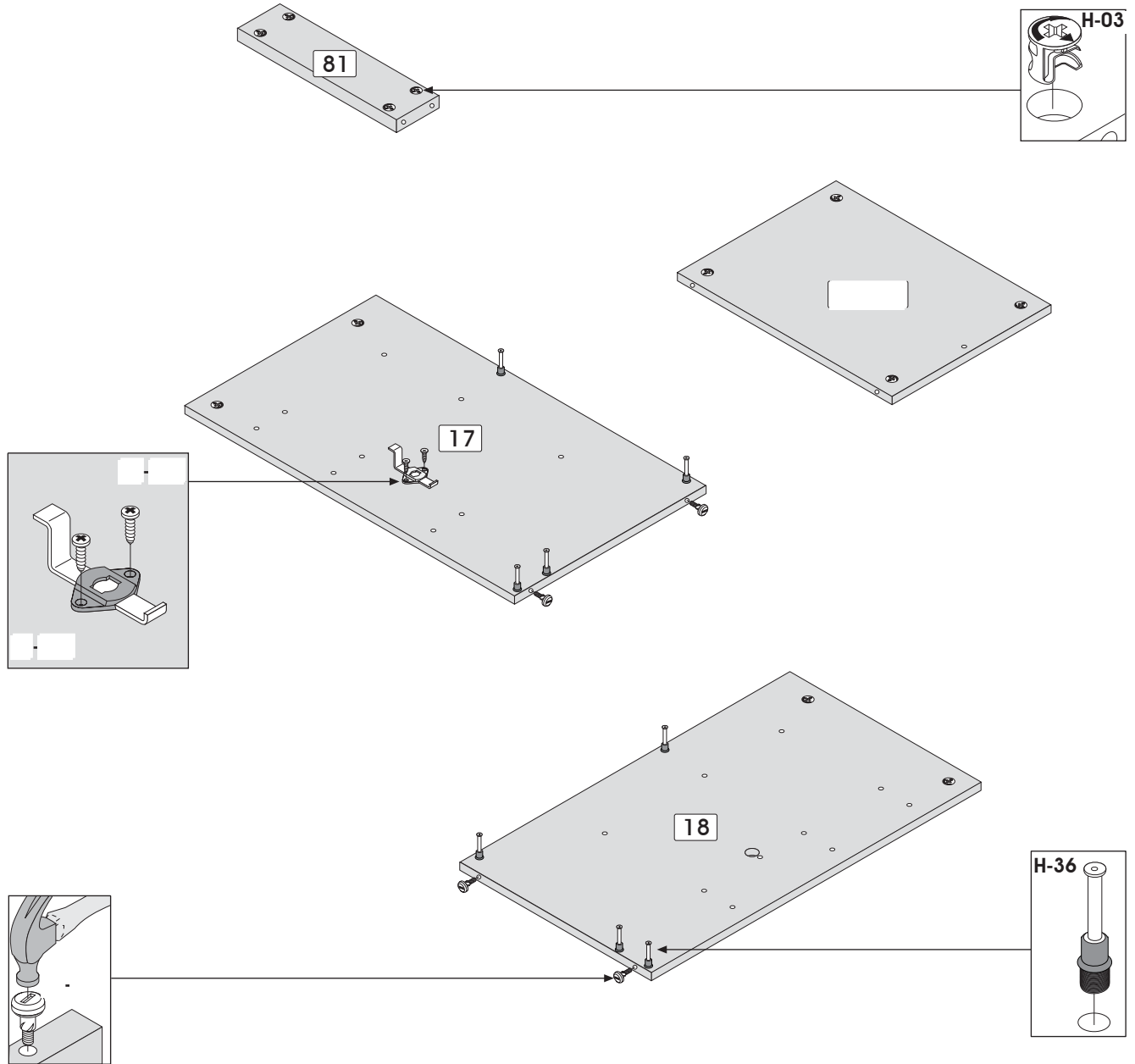

Pedestal with 3 Drawers / Caisson à trois tiroirs / Modulo con tres cajones

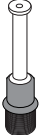

1

					
Code / Código	H-03	H-36	PA-844 1" (25 mm)	SE-686	VR-207 1/2" (13 mm)
Qty / Qté / Cant.	x 12	x 8	x 4	x 1	x 2

2 HARDWARE INSTALLATION / INSTALLATION DES QUINCAILLERIES / INSTALACIÓN DE LAS QUINCALLAS

Pedestal with 3 Drawers / Caisson à trois tiroirs / Modulo con tres cajones

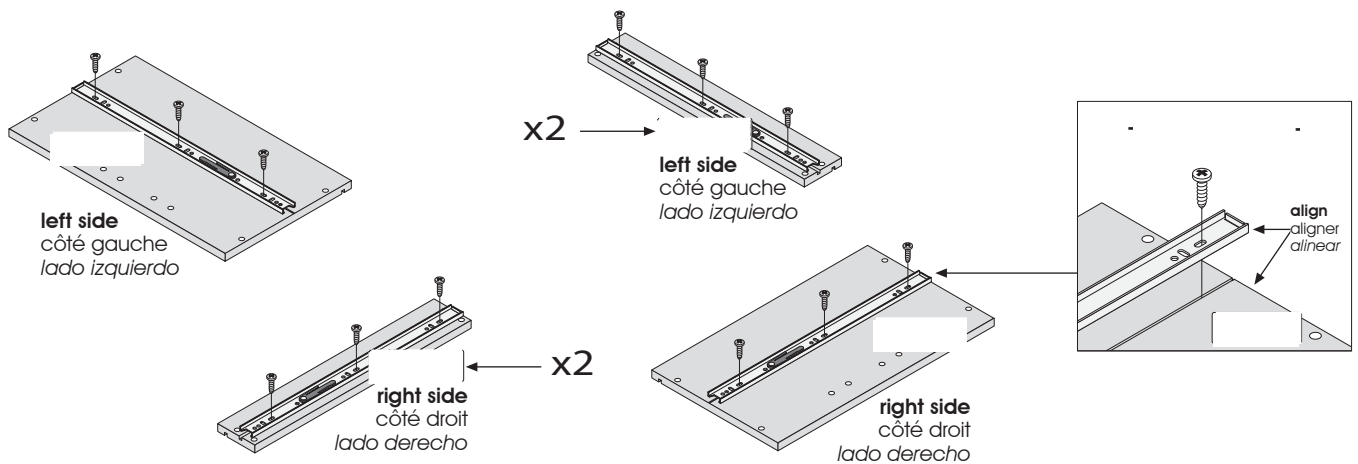
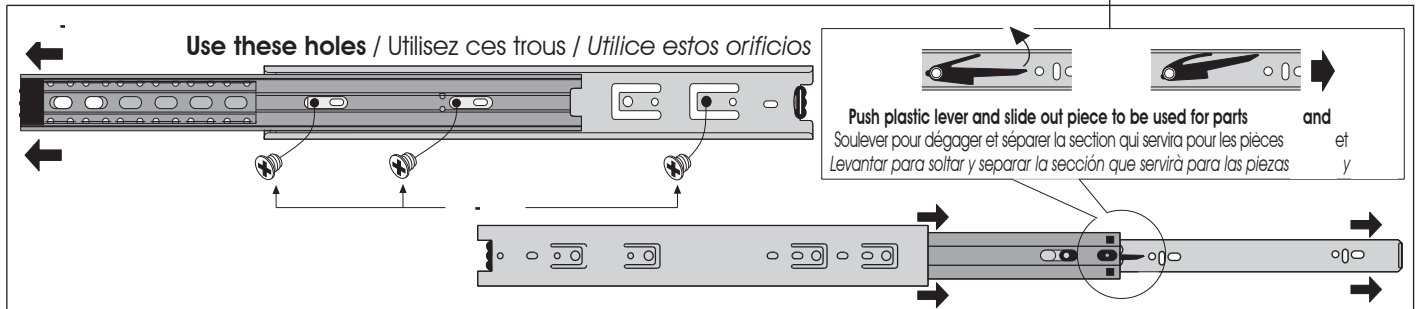
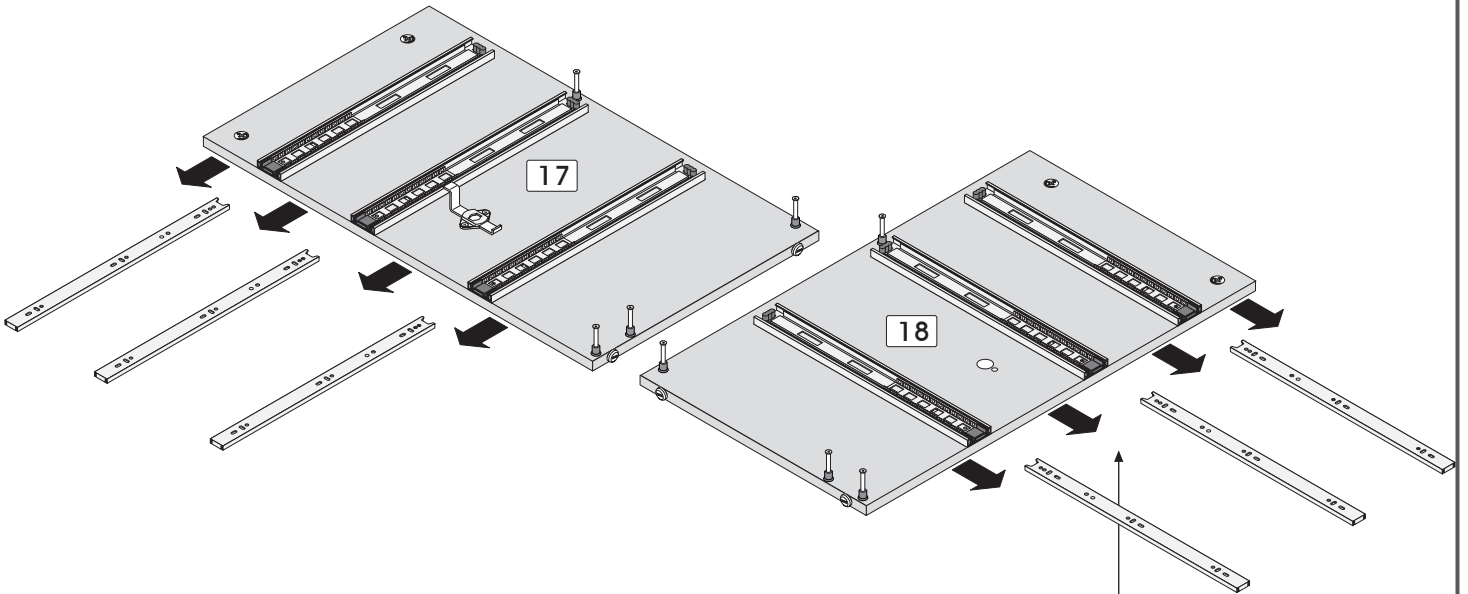

2

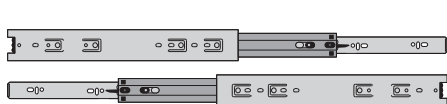

Code / Código

Qty / Qté / Cant.

x 3



x 18



x 18

IMPORTANT NOTICE / NOTE IMPORTANTE / NOTA IMPORTANTE

▶ Main hardware system / Système de quincaillerie principal / Sistema principal de quincalla

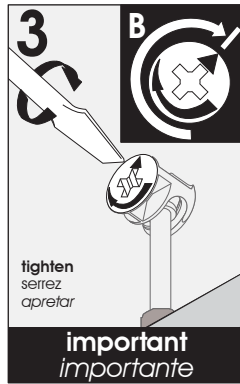
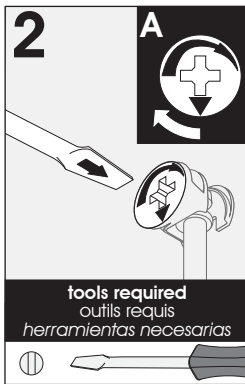
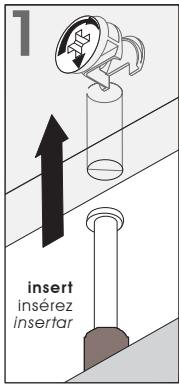

Make sure to properly tighten each cam to ensure furniture solidity. Otherwise, parts could be damaged or the user could be injured.

Assurez-vous de bien resserrer chaque rondelle pour assurer la solidité du meuble. Dans le cas contraire, des pièces pourraient être endommagées ou l'utilisateur pourrait se blesser.

Asegúrese de apretar bien cada arandela para garantizar la solidez del mueble. De lo contrario, podría provocarse daño a las piezas o las personas.

3 ASSEMBLY / ASSEMBLAGE / ENSAMBLAJE

Pedestal with 3 Drawers / Caisson à trois tiroirs / Módulo con tres cajones

Assemble on the back edge
Assemblez sur la bordure arrière
Realice el ensamblaje sobre el borde trasero

Assembling sequence
Séquence d'assemblage
Secuencia de ensamblaje
Parts / Pièces / Piezas:

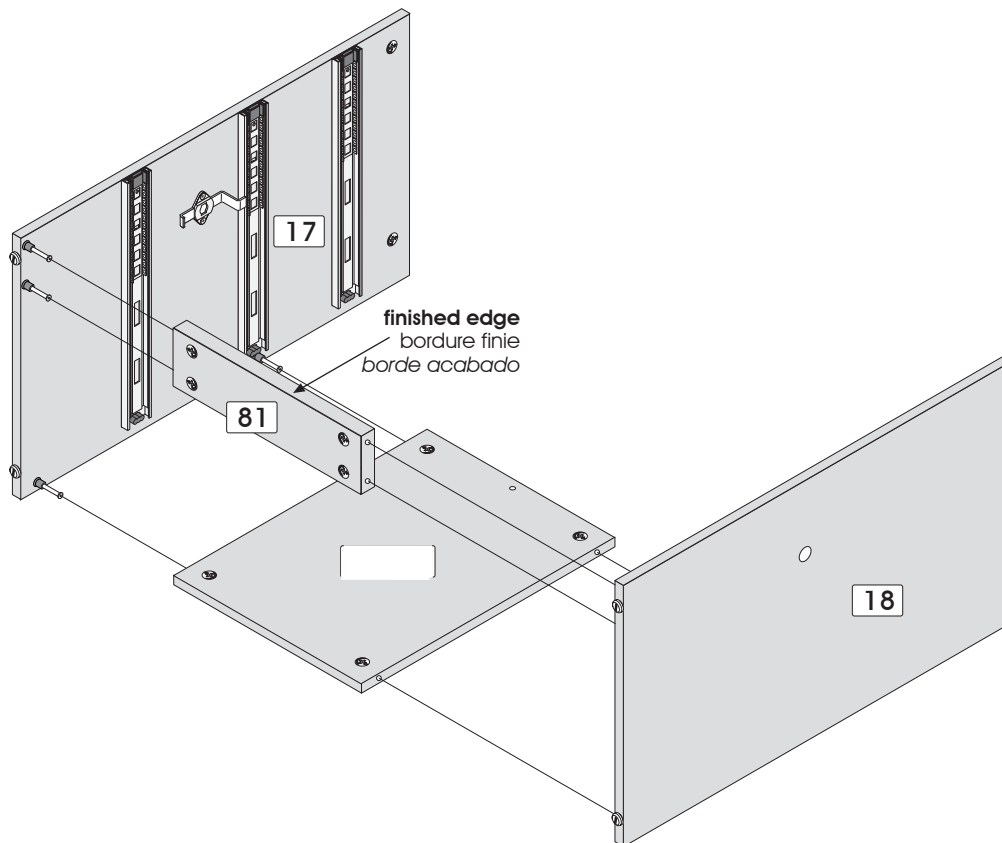

two people are required to assemble and move this model.

deux personnes sont requises pour assembler et déplacer ce modèle.
se necesitan dos personas para ensamblar y desplazar este mueble.

3 possibilities / 3 possibilités / 3 posibilidades

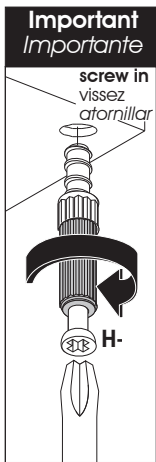
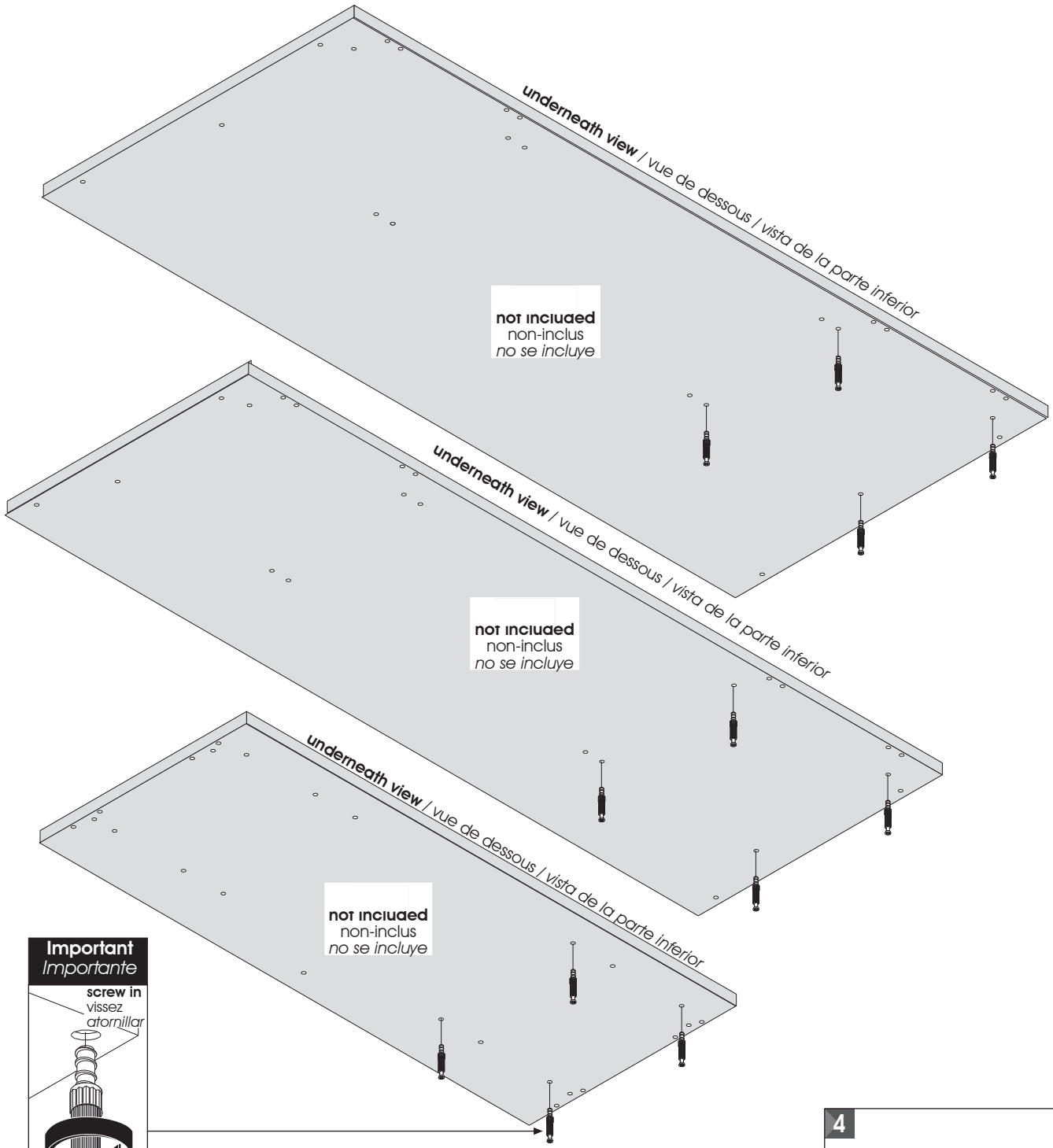

4	
Code / Código	H-
Qty / Qté / Cant.	x 4

5 INSTALLATION / INSTALLATION / INSTALACIÓN

Pedestal with 3 Drawers / Caisson à trois tiroirs / Modulo con tres cajones

Assemble on the back edge

Assemblez sur la bordure arrière

Realice el ensamblaje sobre el borde trasero

Assembling sequence

Séquence d'assemblage

Secuencia de ensamblaje

Parts / Pièces / Piezas:



two people are required to assemble and move this model.

deux personnes sont requises pour assembler et déplacer ce modèle.

se necesitan dos personas para ensamblar y desplazar este mueble.

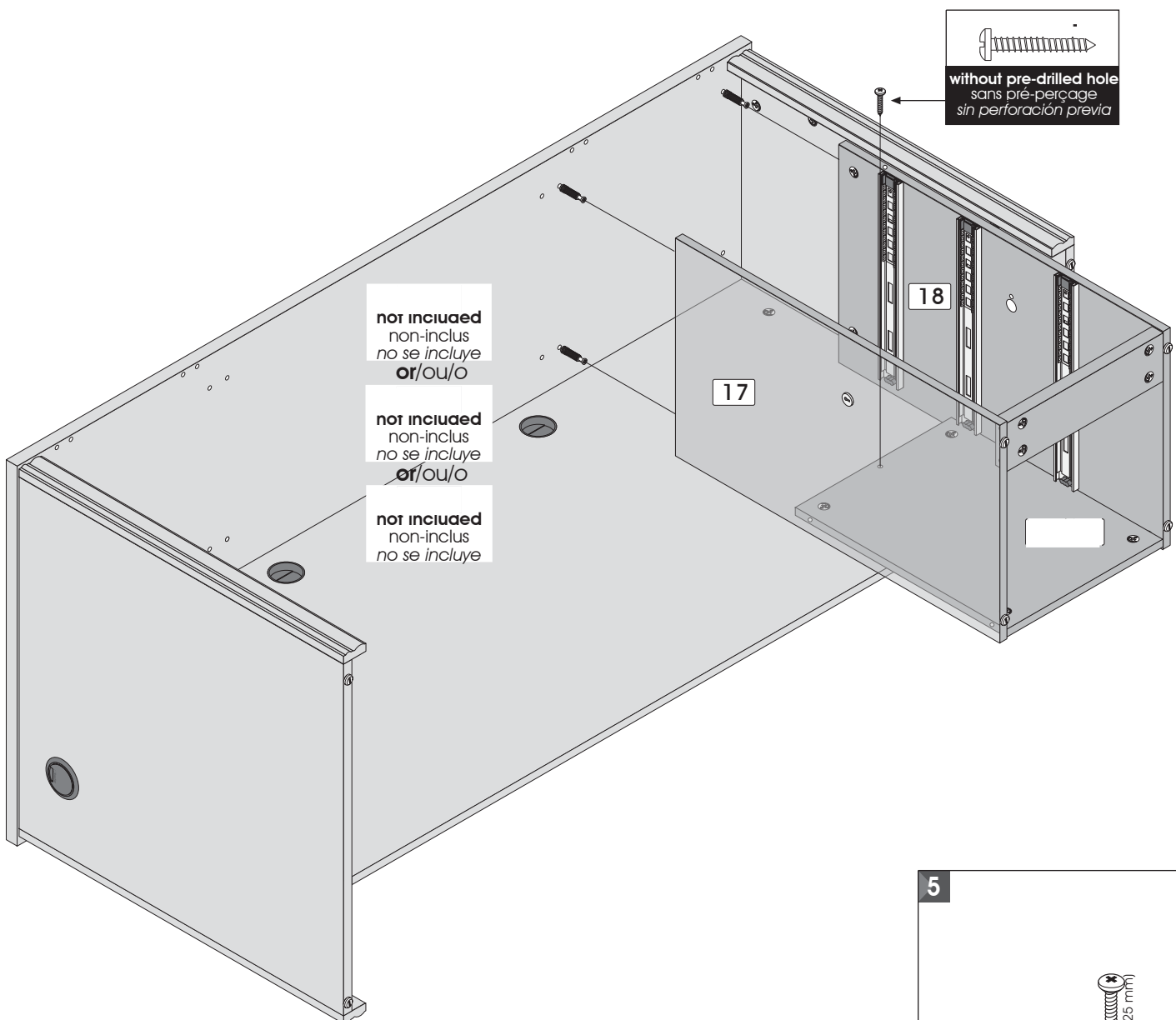
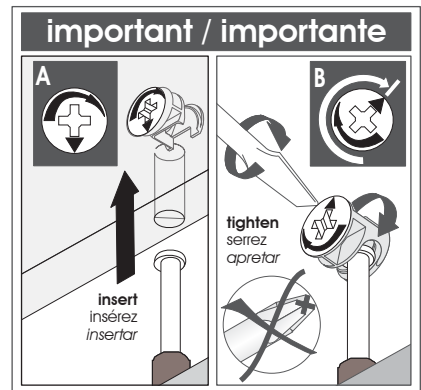

5



Code / Código

Qty / Qté / Cant.

x 1

Drawers / Tiroirs / Cajónes

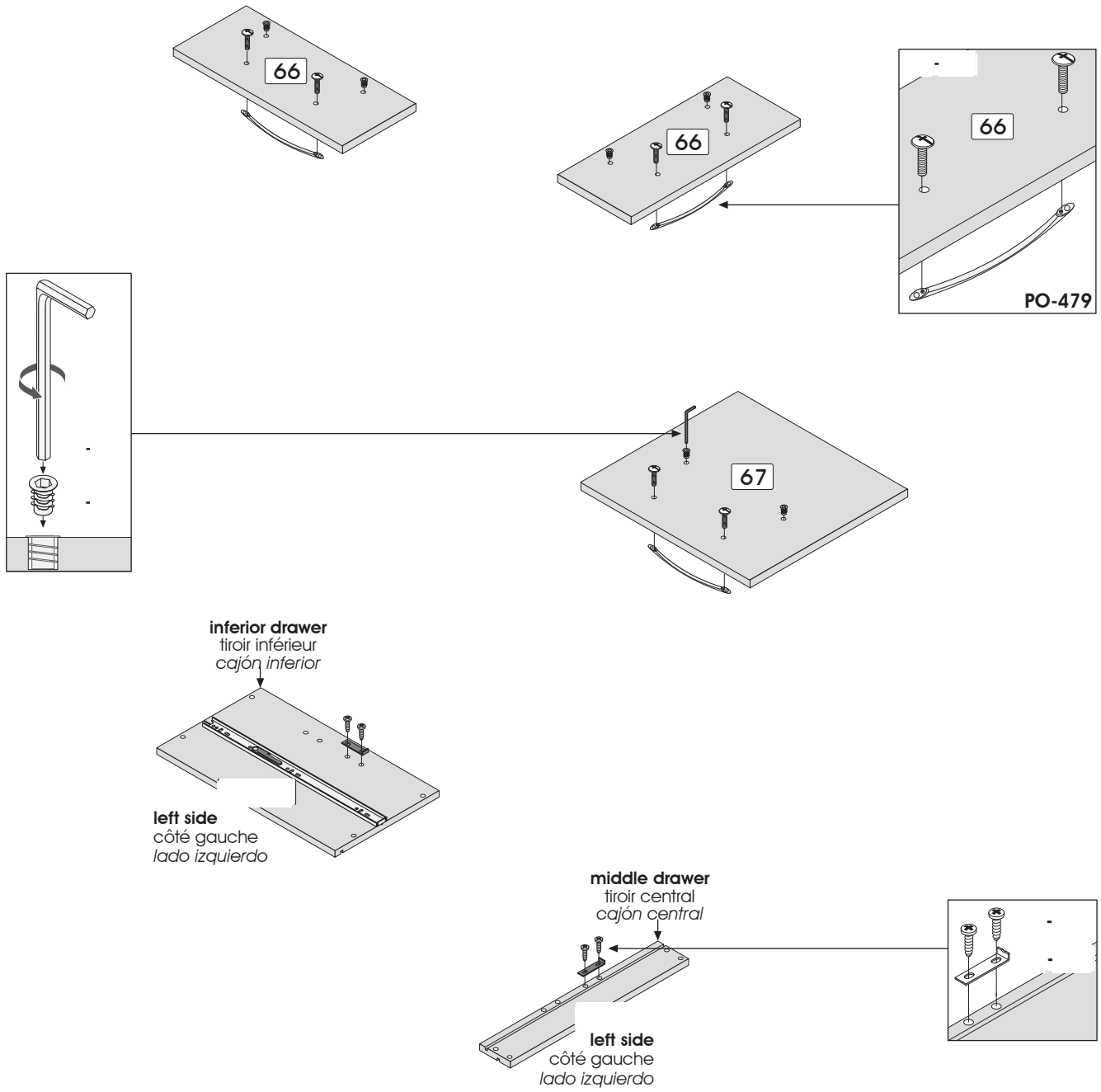

6

Code / Código						
Qty / Qté / Cant.	x 6	x 1	x 2	x 3	x 4	x 6

7

ASSEMBLY / ASSEMBLAGE / ENSAMBLAJE

Superior Drawer / Tiroir supérieur / Cajón superior

Assembling sequence
 Séquence d'assemblage
 Secuencia de ensamblaje
Parts / Pièces / Piezas:

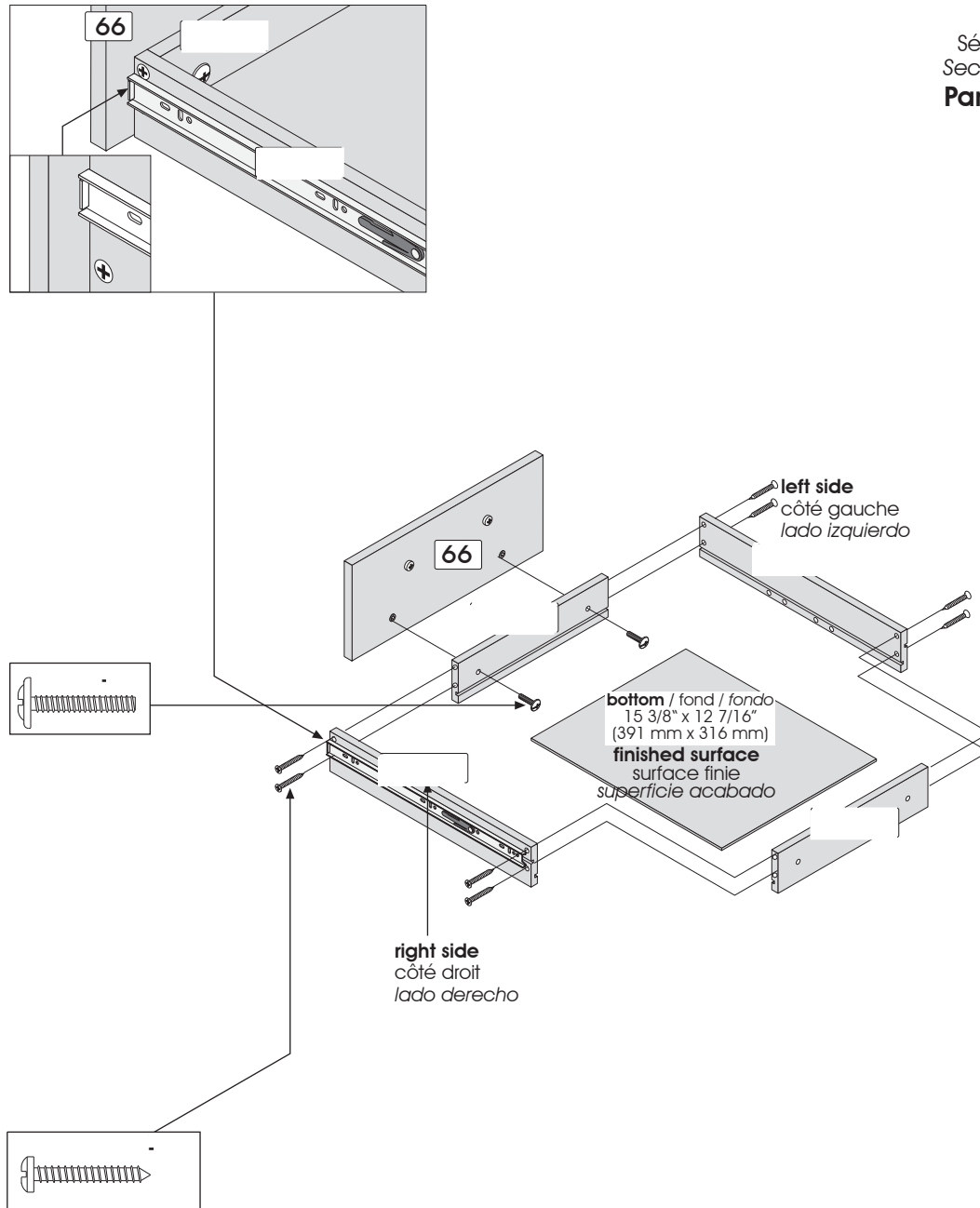

7



VM-601

x 2



VR-212

x 8

Code / Código

Qty / Qté / Cant.

8

ASSEMBLY / ASSEMBLAGE / ENSAMBLAJE

Middle Drawer / Tiroir central / Cajón central

Assembling sequence
 Séquence d'assemblage
 Secuencia de ensamblaje
Parts / Pièces / Piezas:

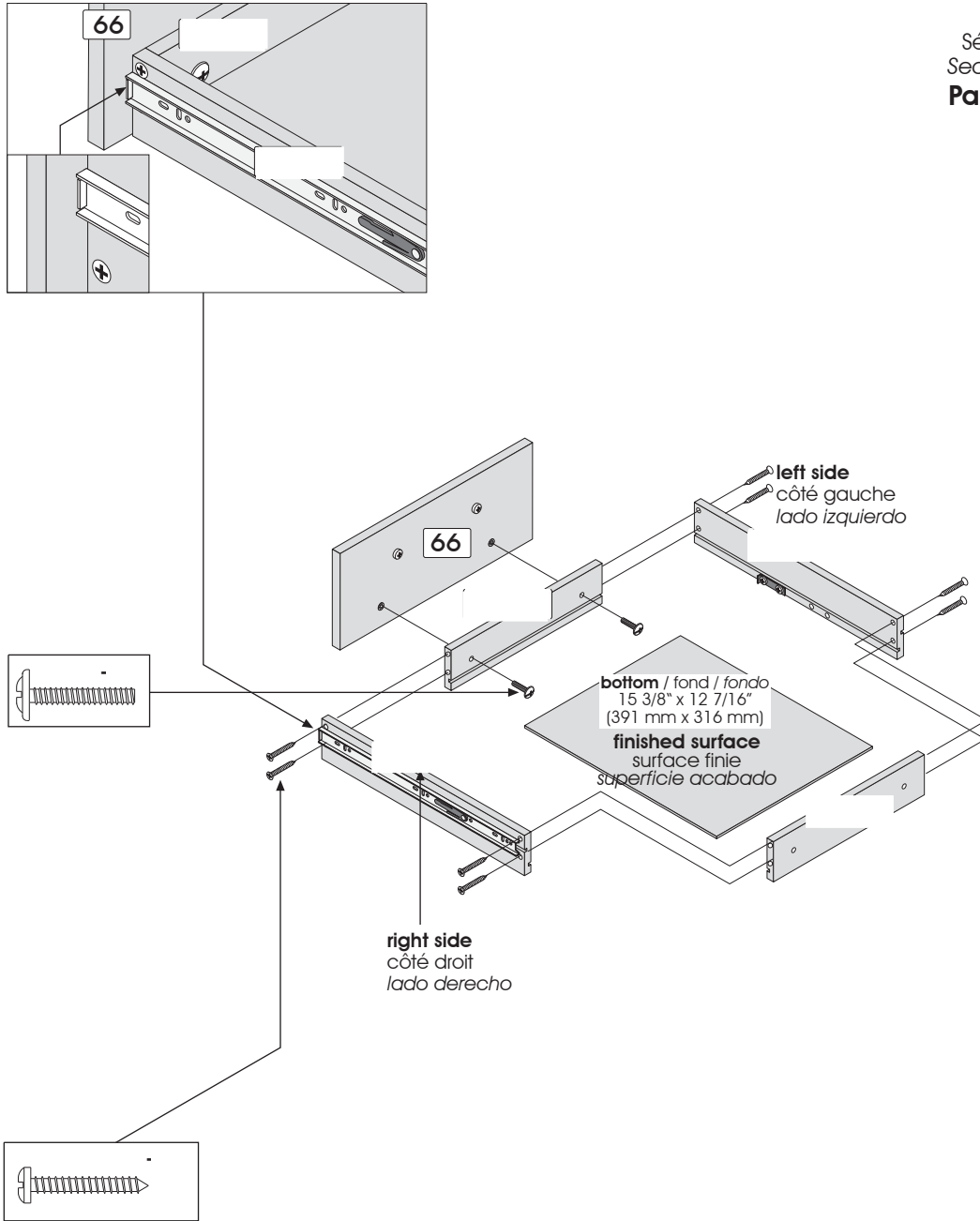

8



3/4" (20 mm)



1" (25 mm) VR

Code / Código

Qty / Qté / Cant.

x 2

x 8

Inferior Drawer / Tiroir inférieur / Cajón inferior

Assembling sequence
 Séquence d'assemblage
 Secuencia de ensamblaje
Parts / Pièces / Piezas:

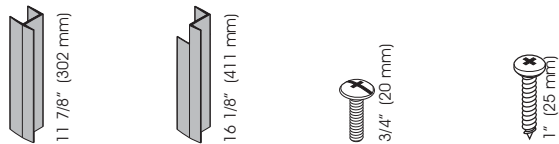
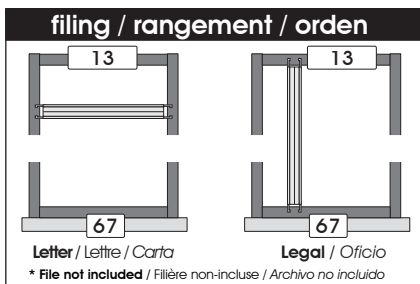
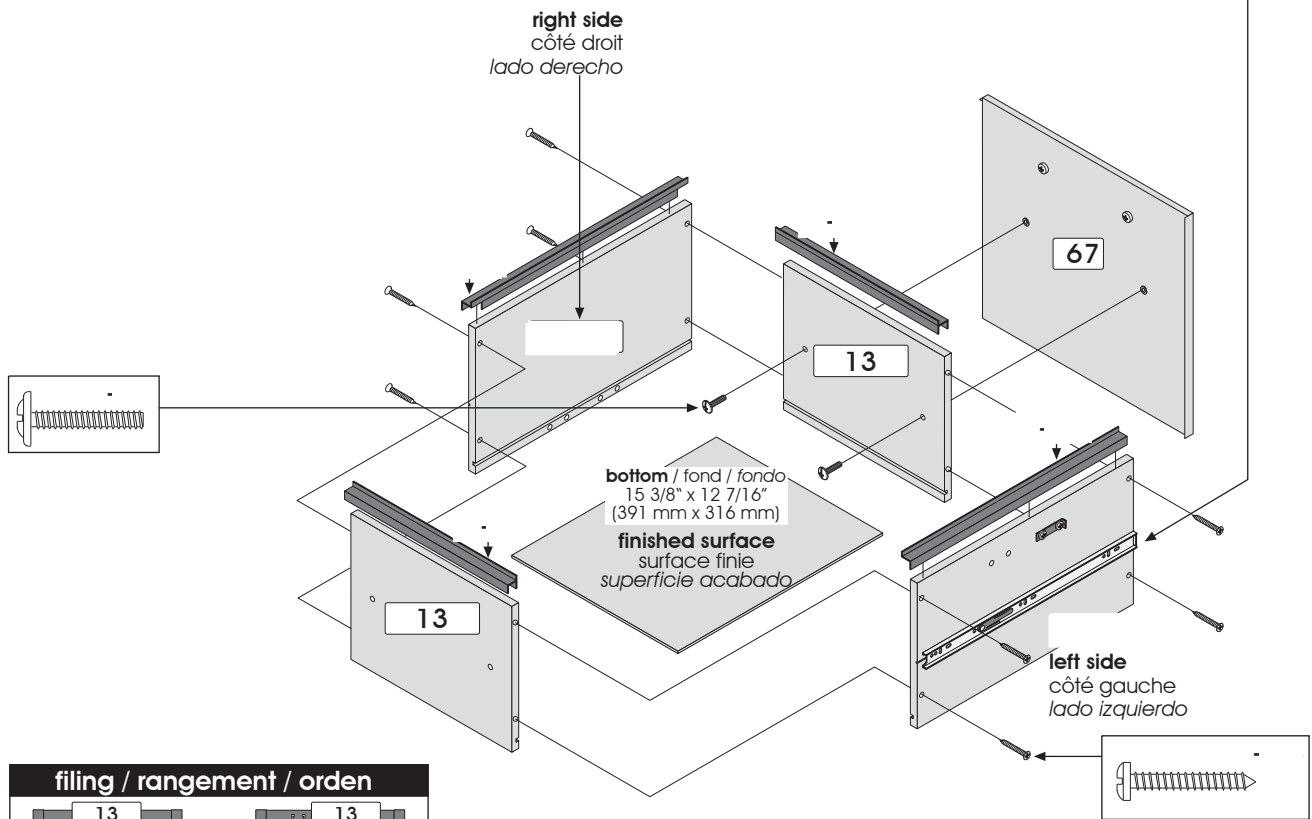
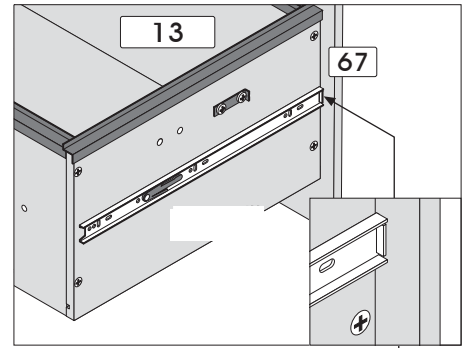

Code / Código

-681

Qty / Qté / Cant.

x 2

x 2

x 2

x 8

Adjustement / Ajustement / Ajuste

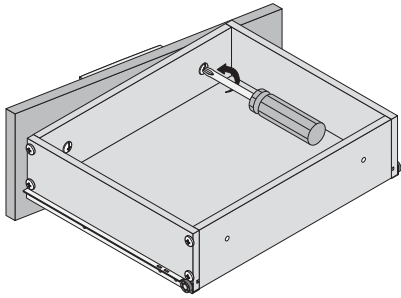

After installing drawers into cabinet, adjust drawer fronts and tighten screws -

Après avoir installé les tiroirs dans le meuble, ajustez les devants de tiroirs et resserrez les vis -

Después de instalar los cajones en el mueble, ajuste las partes delanteras de los cajones y vuelva atornilla a fondo los tornillos VM-601.

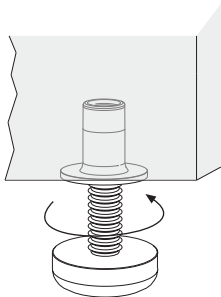
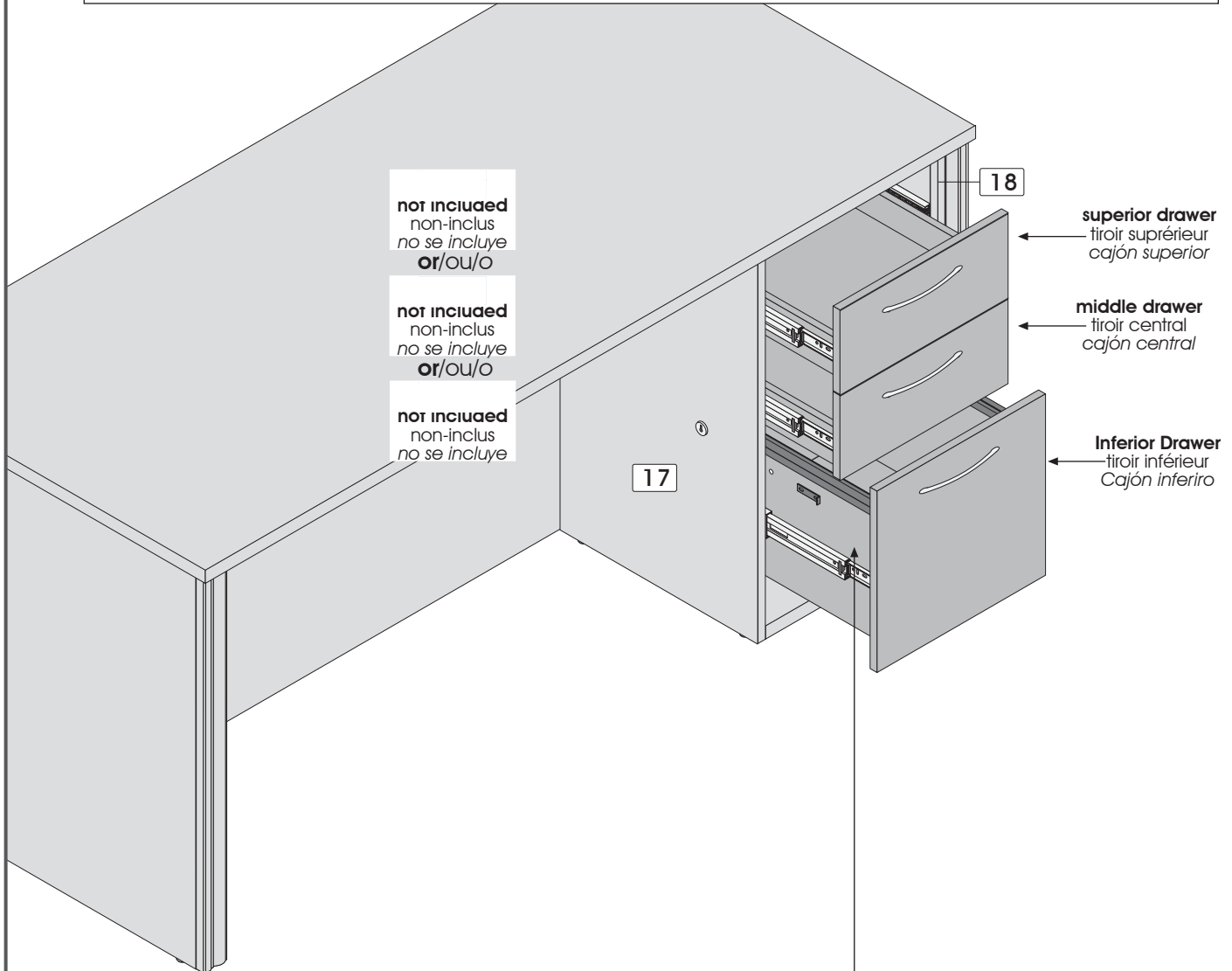

To level your furniture, use leg levelers.

Pour niveler votre meuble utilisez les pattes ajustables.

Para nivelar su mueble utilice las patas ajustables.

Important/Importante

Ball bearings must be on front part of slider when installing drawers.

Les roulements à billes doivent être sur la partie avant du coulisseau lors de l'installation des tiroirs.

Los cojinetes de bolas deben ubicarse sobre la parte delantera de guía en el momento de instalar los cajones.

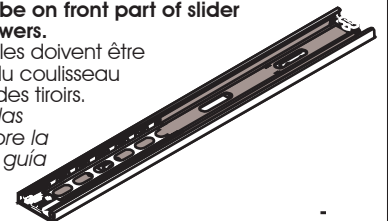

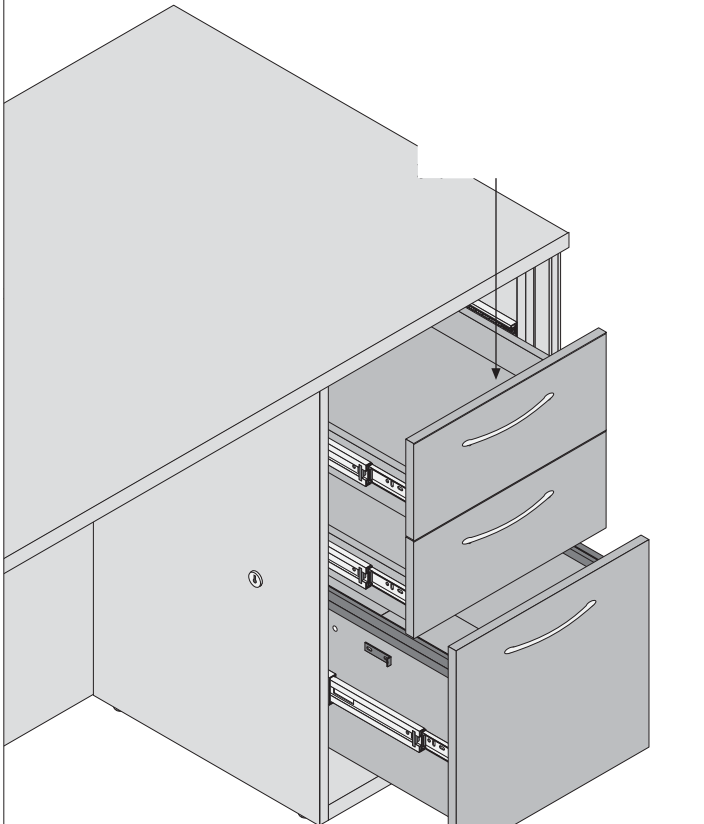
Important/Importante

For future reference and to better serve you, please apply the self-adhesive sticker in an accessible space such as inside a drawer.

Pour mieux vous servir en cas de besoin, veuillez apposer l'auto-collant dans un endroit facilement accessible tel que l'intérieur d'un tiroir.

Para uno mejor servicio en caso de necesidad, poner la etiqueta en uno lugar de fácil acceso como por ejemplo al interior de un cajón.

PRODUCT CARE / ENTRETIEN DU PRODUIT / MANTENIMIENTO DEL PRODUCTO

Avoid placing the furniture in the sunlight or near a source of heat. Use a soft dry cloth for dusting. To clean heavy dirt, use a cloth dipped in a solution of mild detergent and water. Avoid leaving wet objects on the surface or using commercial chemical cleaning products.

Évitez d'exposer le meuble au soleil ou près de toute source de chaleur. Pour le nettoyage, utilisez un chiffon doux et sec. Pour la grosse saleté, utilisez un chiffon humidifié avec un peu de détergent dilué dans l'eau. Évitez de laisser des objets mouillés sur la surface de votre meuble ou d'utiliser des nettoyants chimiques.

Evite exponer el mueble al sol o las fuentes de calor. Para limpiarlo, utilice un paño suave y seco. Para limpiar las manchas rebeldes, utilice un trapo húmedo con un poco de detergente diluido en agua. No deje objetos mojados encima del mueble ni utilice limpiadores que contengan productos químicos. química.

CONGRATULATIONS! YOU ARE NOW THE OWNER OF A QUALITY PRODUCT
FÉLICITATIONS! VOUS AVEZ MAINTENANT EN VOTRE POSSESSION UN PRODUIT DE QUALITÉ
FELICITACIONES! AHORA ES USTED DUEÑO DE UN PRODUCTO DE CALIDAD.

► PARTS / PIÈCES / PIEZAS

CODE / CÓDIGO	QTY / QTÉ / CANT.	CODE / CÓDIGO	QTY / QTÉ / CANT.	CODE / CÓDIGO	QTY / QTÉ / CANT.	CODE / CÓDIGO	QTY / QTÉ / CANT.
_____	4	_____	2	_____	2	_____	1
_____	4	_____	1	_____	1	bottom / fond / fondo 15 3/8" x 12 7/16" (391 mm x 316 mm)	3
_____	2	_____	1	_____	1		



two people are required to assemble and move this model.
deux personnes sont requises pour assembler et déplacer ce modèle.
se necesitan dos personas para ensamblar y desplazar este mueble.









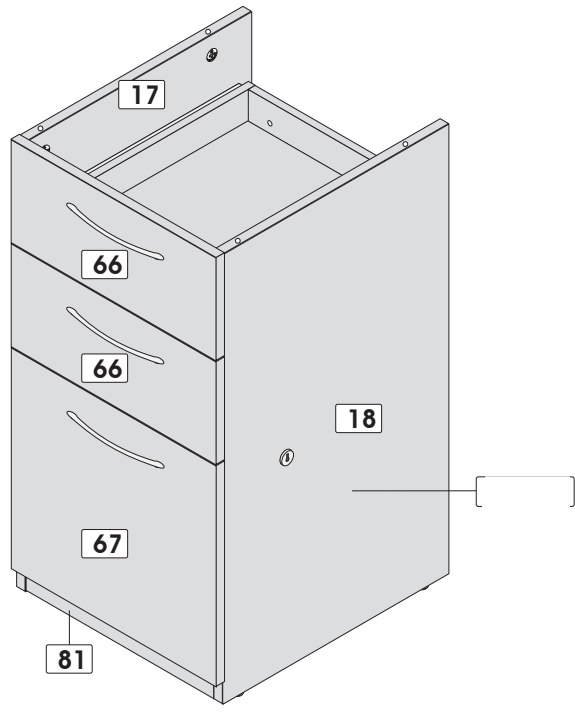







the use of electric tools must be made with vigilance.
l'utilisation d'outils électriques doit être faite avec vigilance.
las herramientas eléctricas deben utilizarse con sumo cuidado.

tools required
outils requis
herramientas necesarias

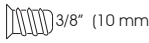
#3
1/4" (7 mm)

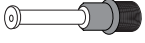
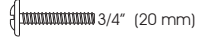

HARDWARES / QUINCAILLERIES / QUINCALLAS

CODE / CÓDIGO	QTY / QTÉ / CANT.	CODE / CÓDIGO	QTY / QTÉ / CANT.	CODE / CÓDIGO	QTY / QTÉ / CANT.	CODE / CÓDIGO	QTY / QTÉ / CANT.
	1	 16 1/8" (411 mm)	2		3	 1" (25 mm)	25
runners 406 mm (16") coulisseaux 406 mm correderas 406 mm	3		12		1		
	2		4	 3/8" (10 mm)	18		
	6		8	 3/4" (20 mm)	12		
 11 7/8" (302 mm)	2	 1" (25 mm)	4	 1/2" (13 mm)	24		

REAL SIZE / GRANDEUR RÉELLE / TAMAÑO REAL

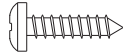
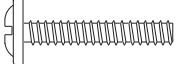
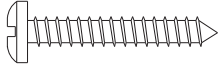
CODE / CÓDIGO	QTY / QTÉ / CANT.	CODE / CÓDIGO	QTY / QTÉ / CANT.
 3/8" (10 mm)	18	 1/2" (13 mm)	24
 3/4" (20 mm)	12	 1" (25 mm)	25

IMPORTANT NOTICE / NOTE IMPORTANTE / NOTA IMPORTANTE

Group together all the hardware required for each step as the construction of your piece of furniture is progressing.

Regroupez toutes les quincailleries requises pour chaque étape de façon à vous assurer de tout installer au bon moment.

Reúna todas las quincallas necesarias para cada una de las etapas de montaje, para asegurar una correcta instalación en el momento adecuado.

▶ IMPORTANT NOTICE / NOTE IMPORTANTE / NOTA IMPORTANTE

Duly complete the self-adhesive sticker. / Assurez-vous de bien remplir l'autocollant. / Asegúrese de completar correctamente la etiqueta.

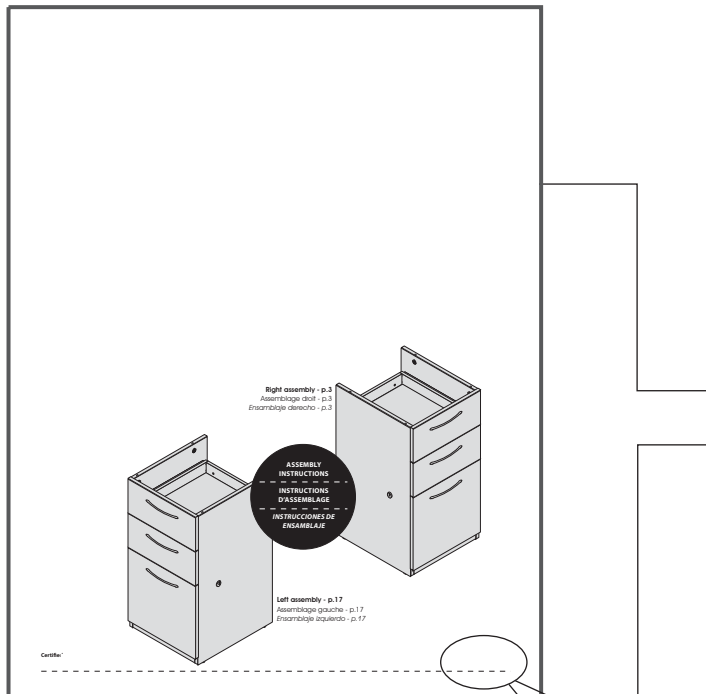

Important/Importante

Please retain the self-adhesive sticker which you will install at step 11 of the instruction manual.

Conservez l'autocollant qui sera collé seulement à l'étape 11 du feuillet d'instructions.

Conserve la etiqueta que será pegada sólo en la etapas 11 de la hoja de instrucciones.

▶ IMPORTANT NOTICE / NOTE IMPORTANTE / NOTA IMPORTANTE

▶ Main hardware system / Système de quincaillerie principal / Sistema principal de quincalla

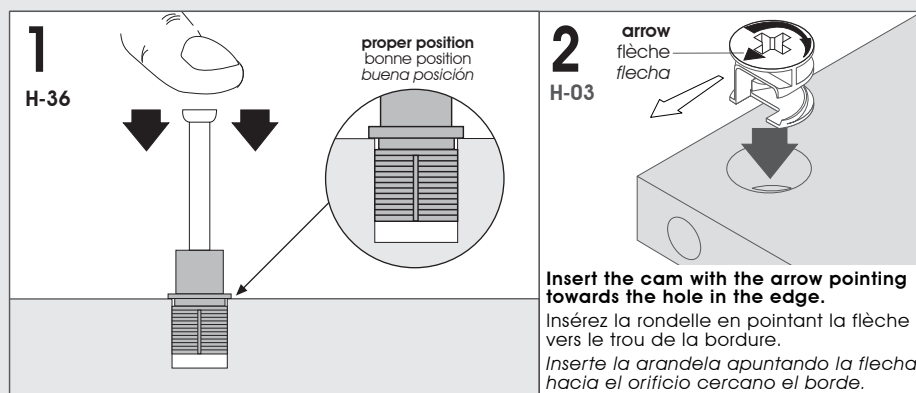



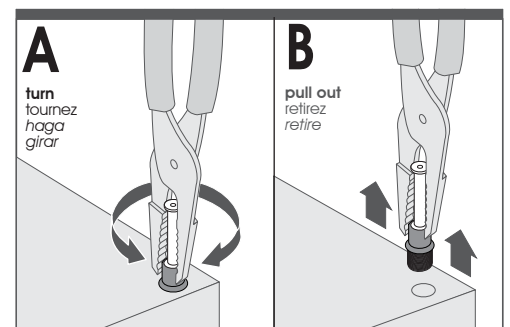

If needed / En cas de nécessité
En caso de necesidad

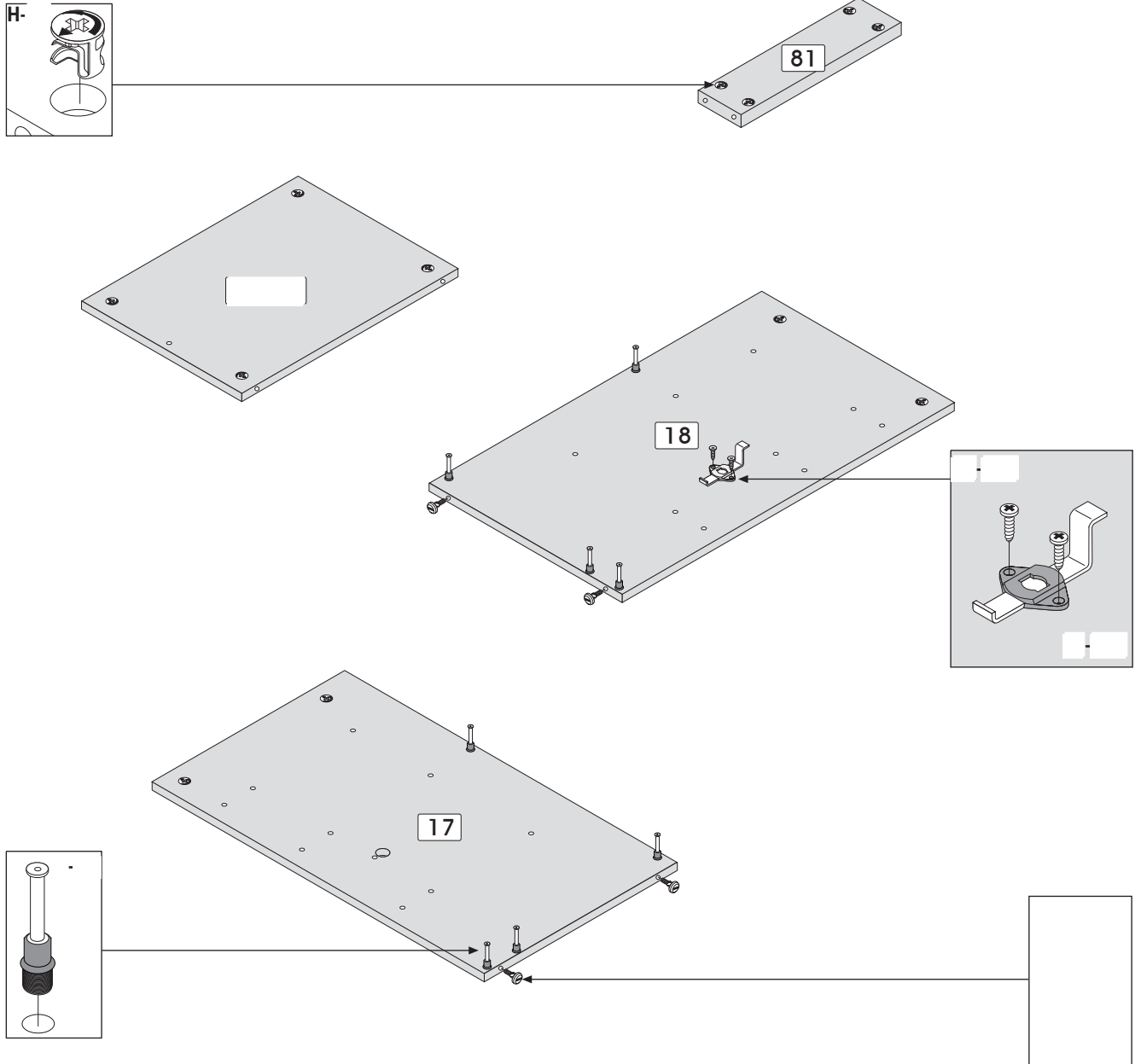

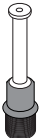
Pedestal with 3 Drawers / Caisson à trois tiroirs / Modulo con tres cajónes



Code / Código	Qty / Qté / Cant.
	x 12
	x 8
 1" (25 mm)	x 4
	x 1
 1/2" (13 mm)	x 2

2 **HARDWARE INSTALLATION / INSTALLATION DES QUINCAILLERIES / INSTALACIÓN DE LAS QUINCALLAS**

Pedestal with 3 Drawers / Caisson à trois tiroirs / Modulo con tres cajones

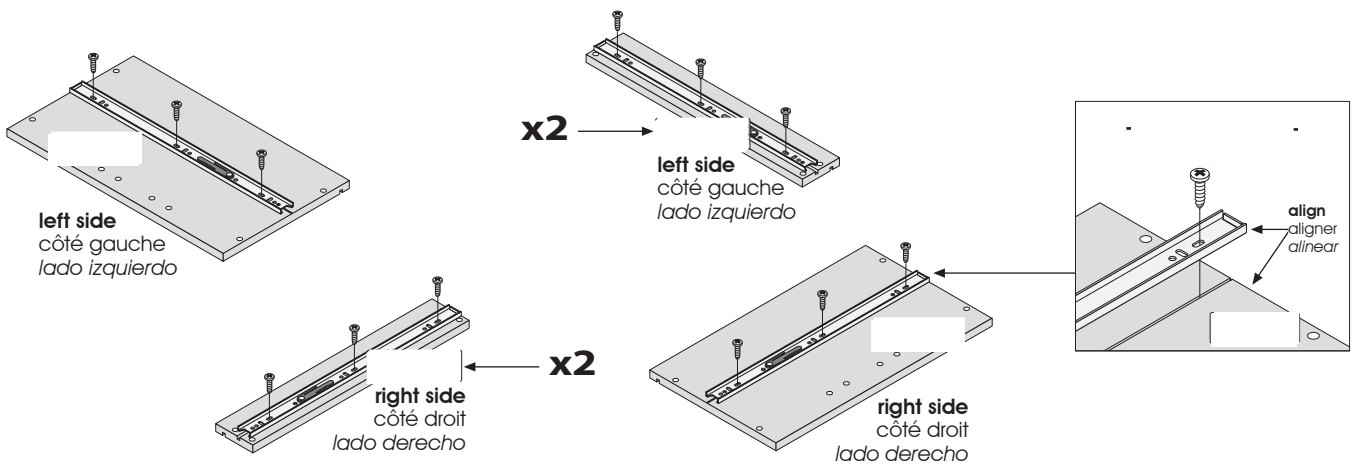
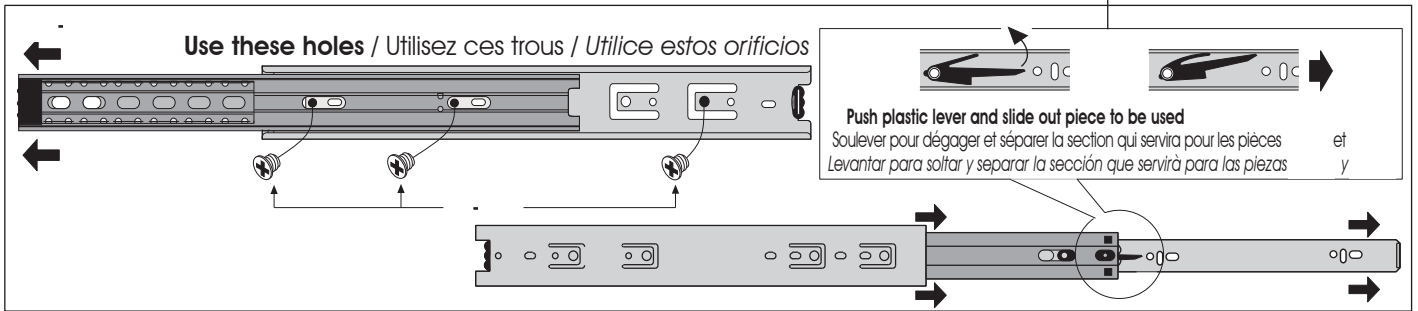
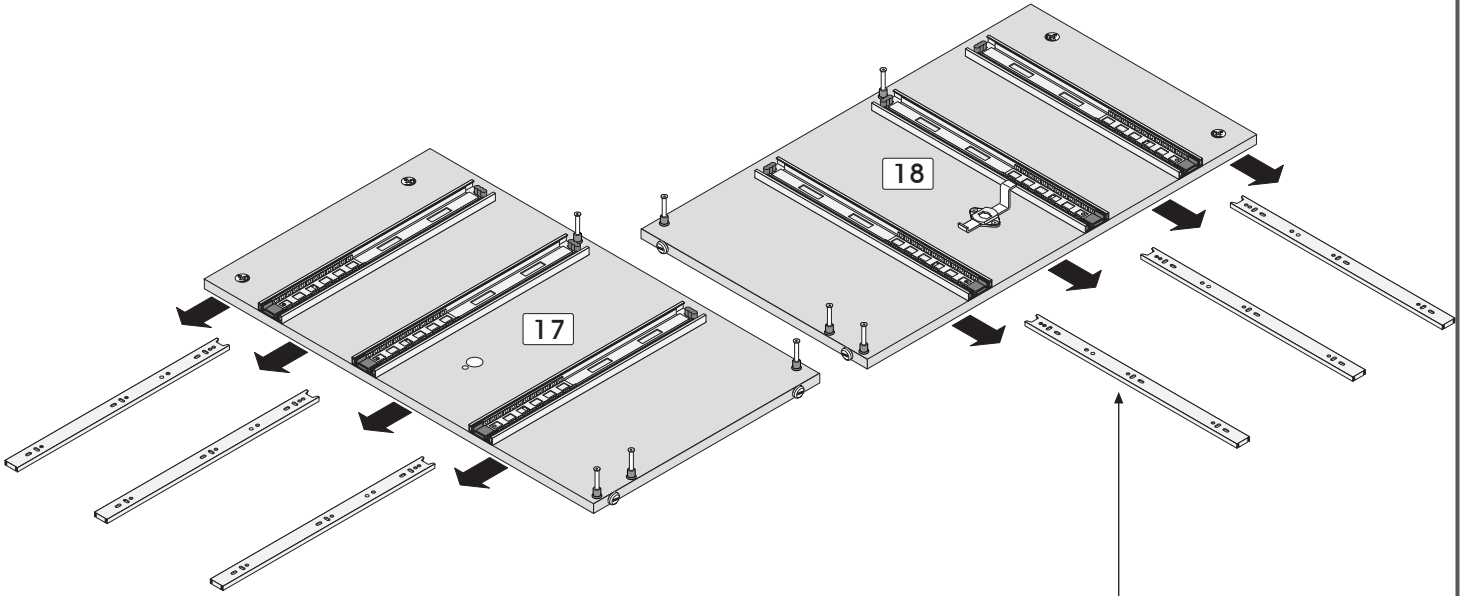

2

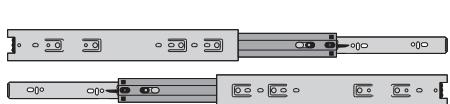

Code / Código

Qty / Qté / Cant.

x 3

x 18

x 18

IMPORTANT NOTICE / NOTE IMPORTANTE / NOTA IMPORTANTE

▶ Main hardware system / Système de quincaillerie principal / Sistema principal de quincalla

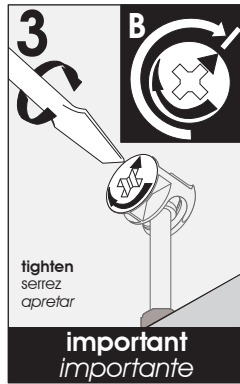
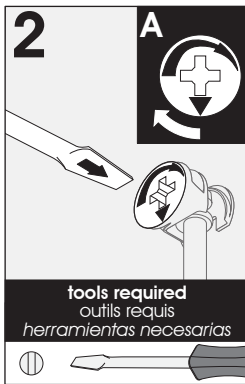
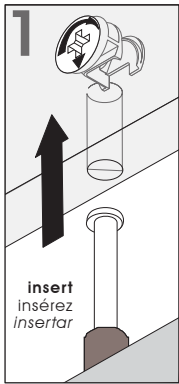

Make sure to properly tighten each cam to ensure furniture solidity. Otherwise, parts could be damaged or the user could be injured.

Assurez-vous de bien resserrer chaque rondelle pour assurer la solidité du meuble. Dans le cas contraire, des pièces pourraient être endommagées ou l'utilisateur pourrait se blesser.

Asegúrese de apretar bien cada arandela para garantizar la solidez del mueble. De lo contrario, podría provocarse daño a las piezas o las personas.

3 ASSEMBLY / ASSEMBLAGE / ENSAMBLAJE

Pedestal with 3 Drawers / Caisson à trois tiroirs / Módulo con tres cajones

Assemble on the back edge
Assemblez sur la bordure arrière
Realice el ensamblaje sobre el borde trasero

Assembling sequence
Séquence d'assemblage
Secuencia de ensamblaje
Parts / Pièces / Piezas:

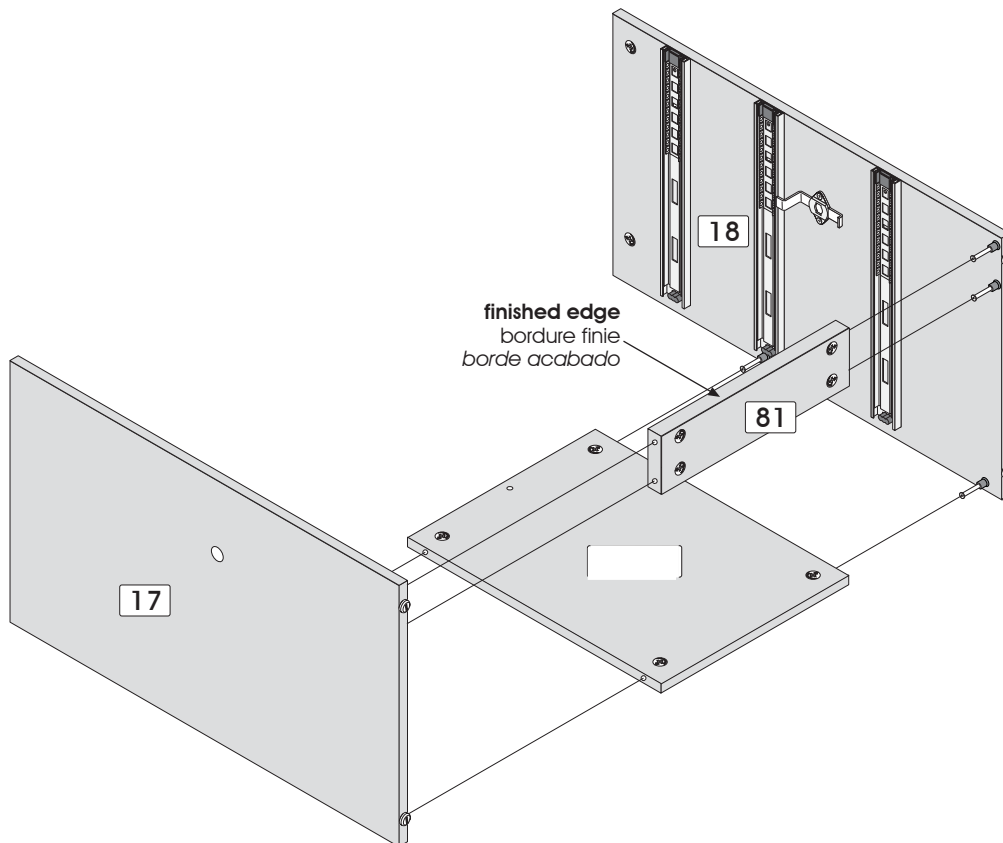

two people are required to assemble and move this model.

deux personnes sont requises pour assembler et déplacer ce modèle.
se necesitan dos personas para ensamblar y desplazar este mueble.

4 HARDWARE INSTALLATION / INSTALLATION DES QUINCAILLERIES / INSTALACIÓN DE LAS QUINCALLAS

Pedestal with 3 Drawers / Caisson à trois tiroirs / Modulo con tres cajones

3 possibilities / 3 possibilités / 3 posibilidades

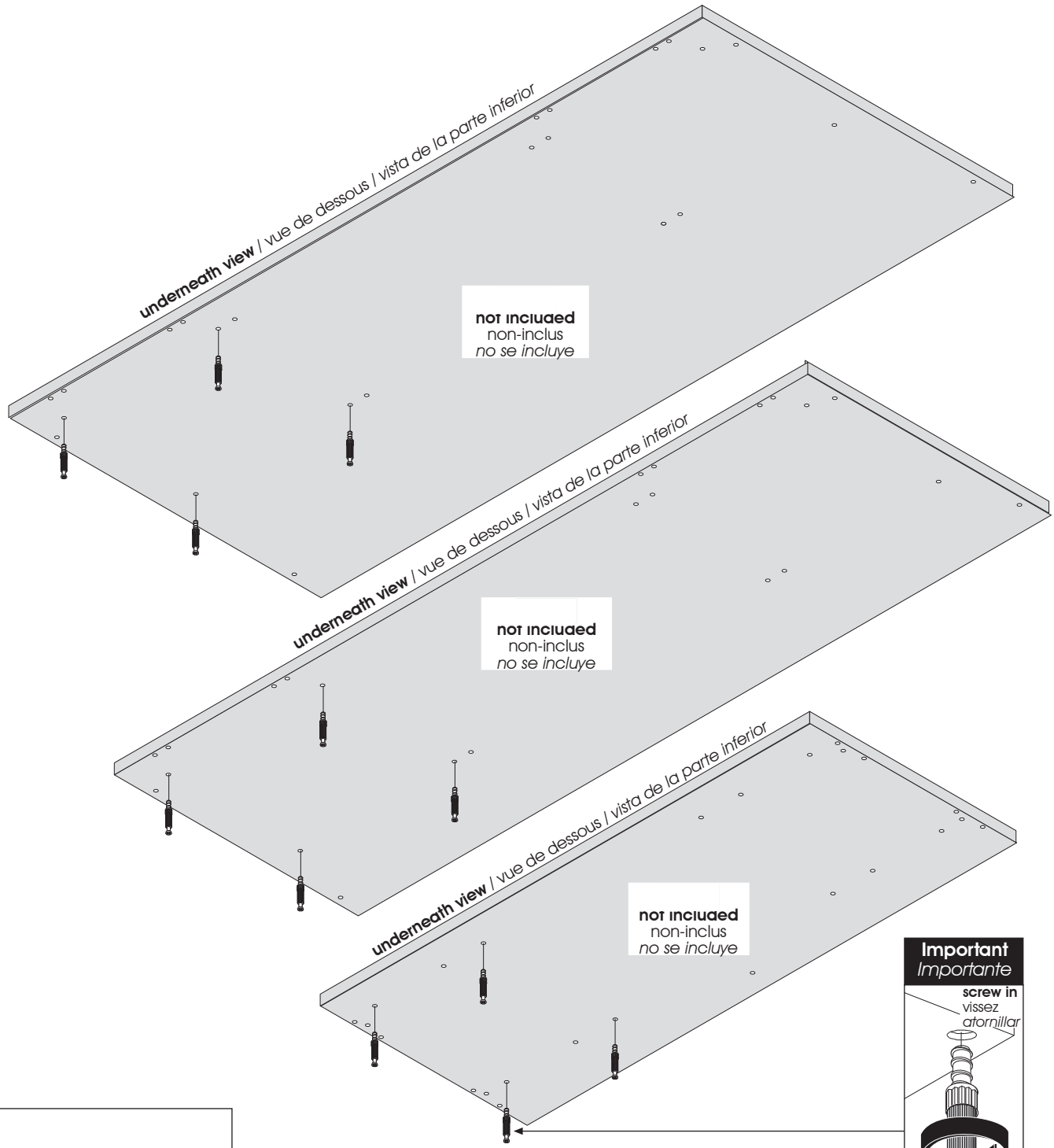

4



Code / Código H-04

Qty / Qté / Cant. x 4

Important
Importante

screw in
vissez
atornillar



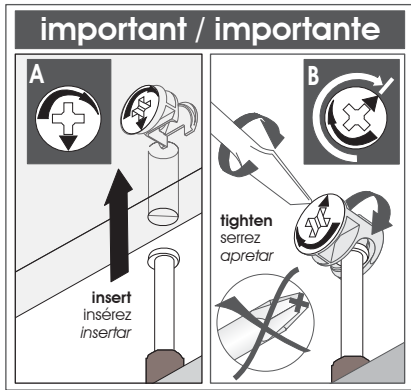

Assemble on the back edge
 Assemblez sur la bordure arrière
 Realice el ensamblaje sobre el borde trasero

Assembling sequence
 Séquence d'assemblage
 Secuencia de ensamblaje
Parts / Pièces / Piezas:



two people are required to assemble and move this model.
 deux personnes sont requises pour assembler et déplacer ce modèle.
 se necesitan dos personas para ensamblar y desplazar este mueble.

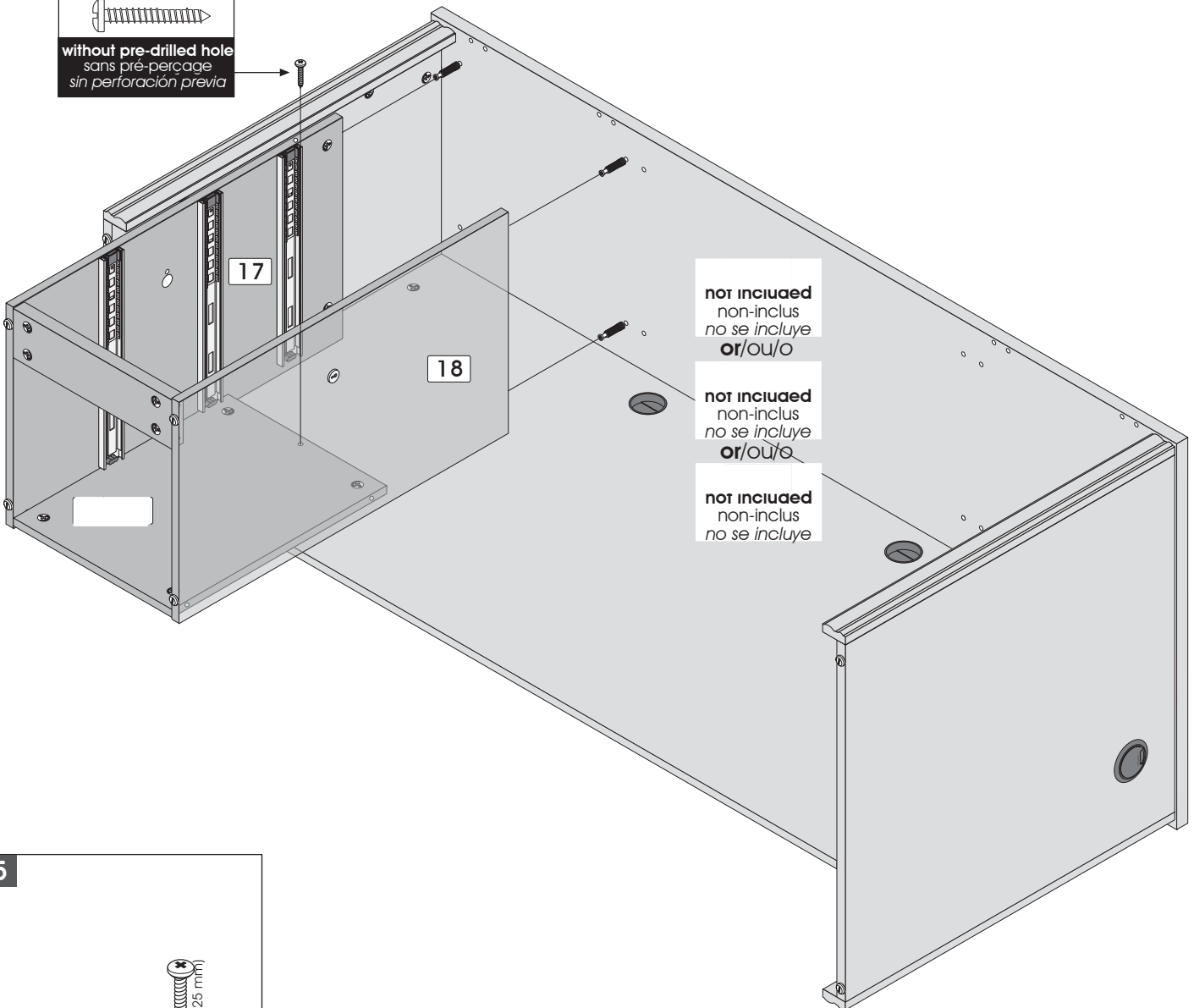
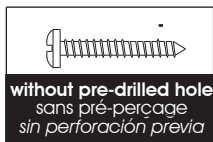

not included
 non-inclus
 no se incluye
or/ou/o

not included
 non-inclus
 no se incluye
or/ou/o

not included
 non-inclus
 no se incluye







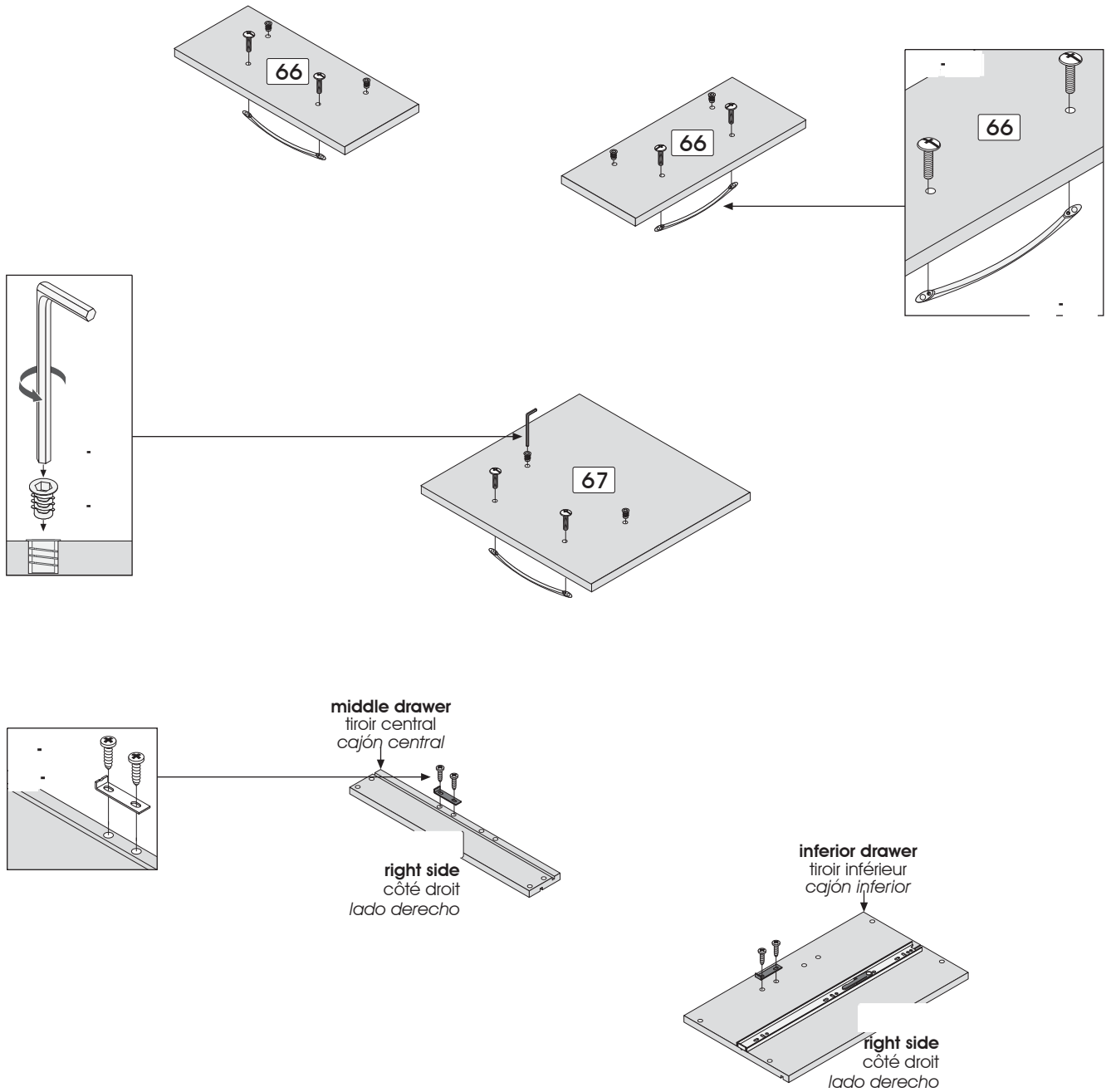

Code / Código VR-212
 Qty / Qté / Cant. x 1

6 HARDWARE INSTALLATION / INSTALLATION DES QUINCAILLERIES / INSTALACIÓN DE LAS QUINCALLAS

Drawers / Tiroirs / Cajónes



6

						
Code / Código					1/2" (13 mm)	3/4" (20 mm)
Qty / Qté / Cant.	x 6	x 1	x 2	x 3	x 4	x 6

Assembling sequence
 Séquence d'assemblage
 Secuencia de ensamblaje
Parts / Pièces / Piezas:

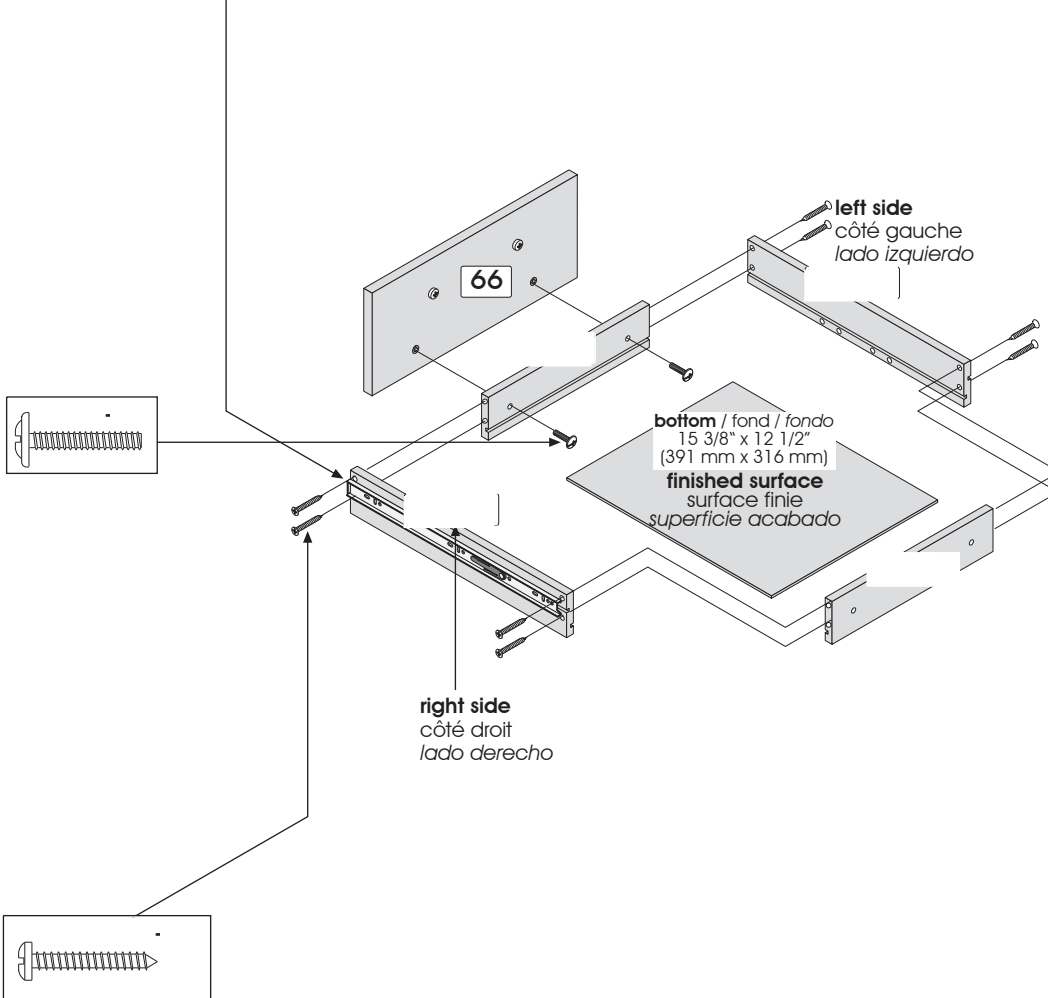
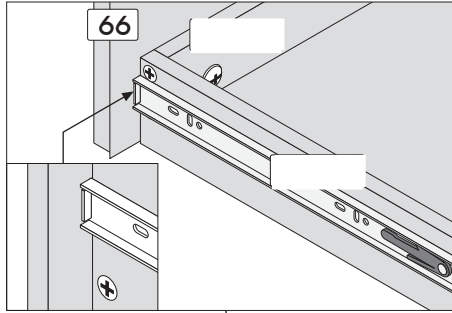

Code / Código VM-601

Qty / Qté / Cant. x 2



Code / Código VR-212

Qty / Qté / Cant. x 8

Middle Drawer / Tiroir central / Cajón central

Assembling sequence
 Séquence d'assemblage
 Secuencia de ensamblaje
Parts / Pièces / Piezas:

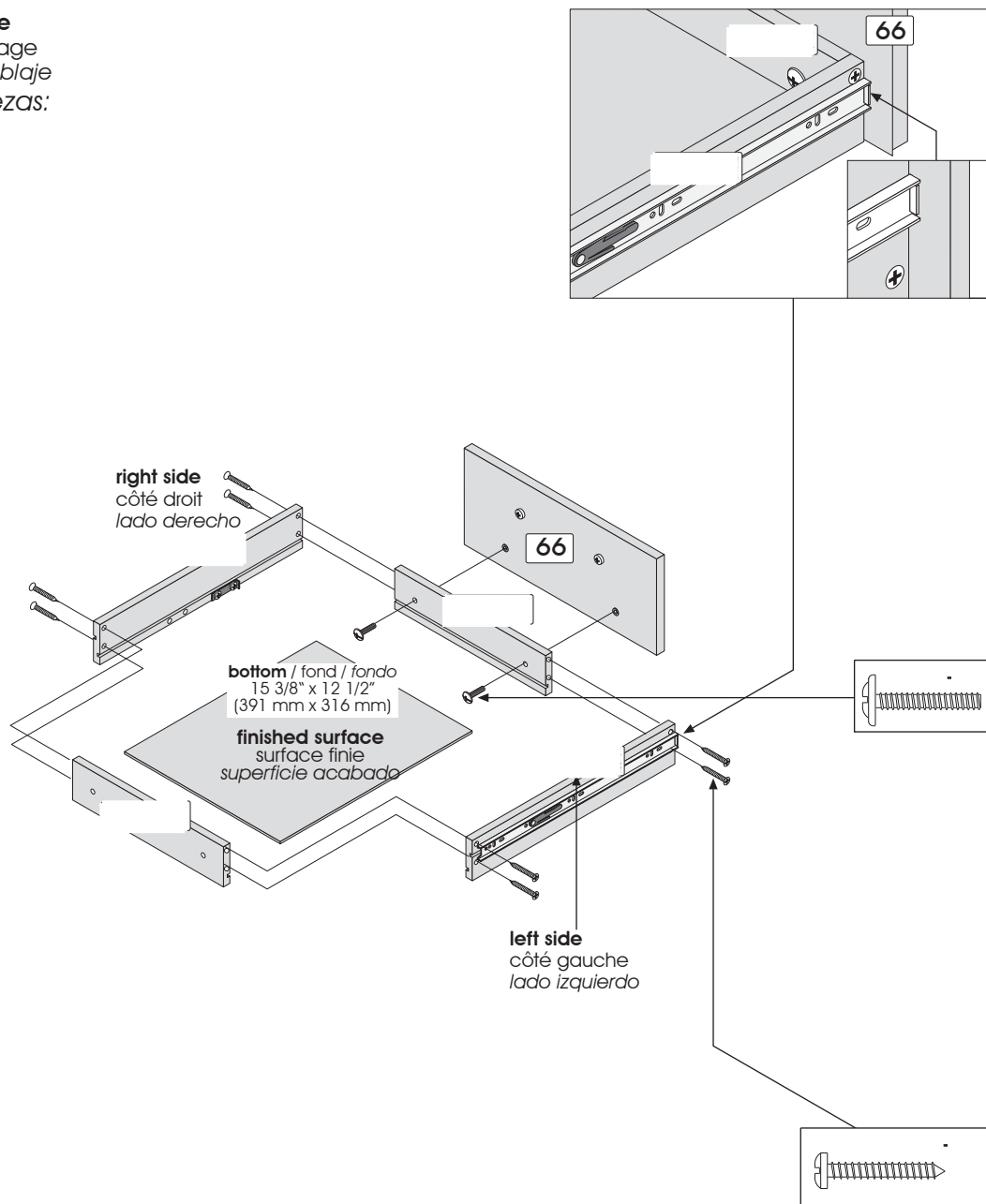

Code / Código VM-601

Qty / Qté / Cant. x 2



Code / Código VR-212

Qty / Qté / Cant. x 8

Code / Código
 Qty / Qté / Cant.

Assembling sequence
 Séquence d'assemblage
 Secuencia de ensamble
Parts / Pièces / Piezas:

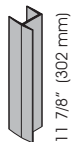
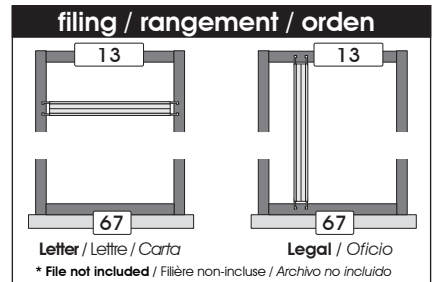
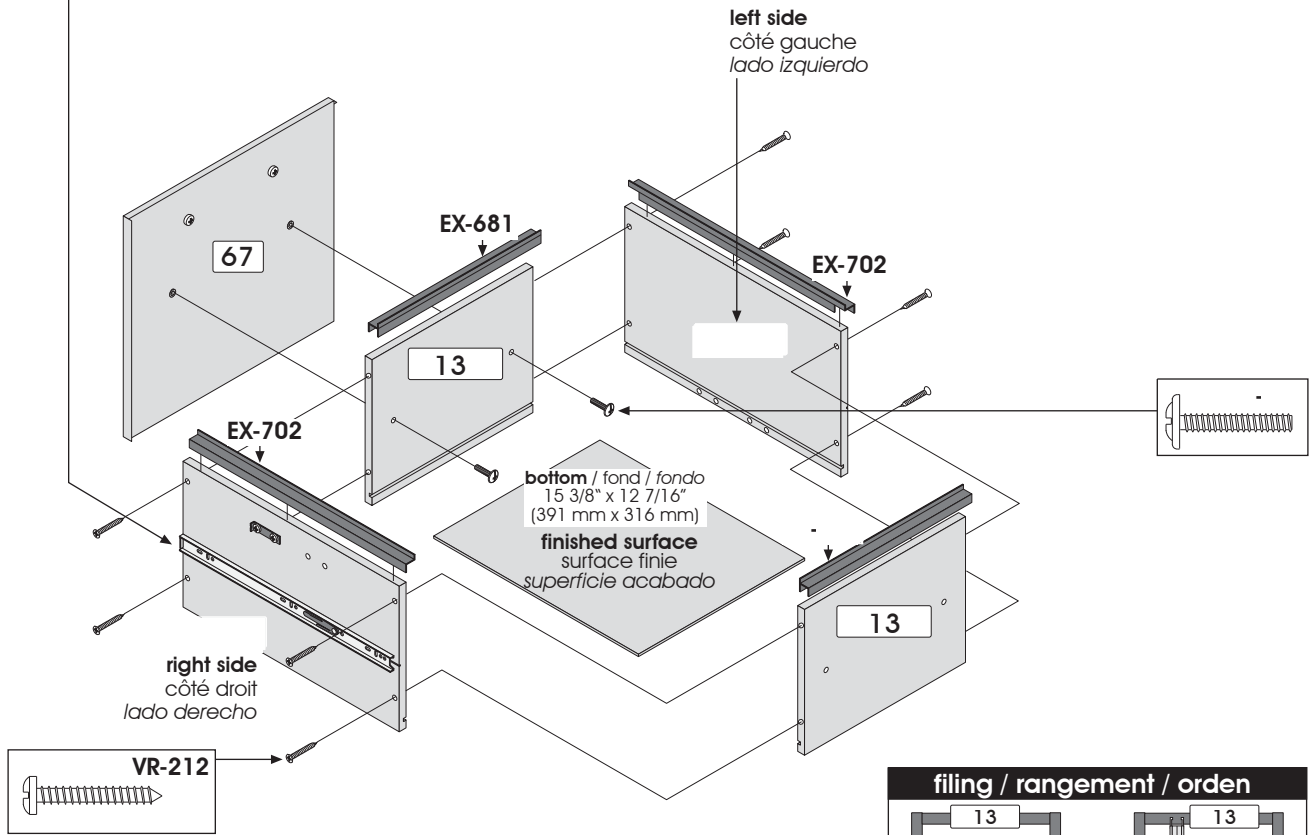
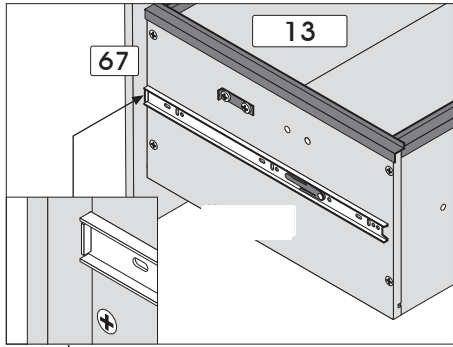

x 2

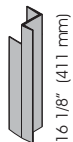

x 2



x 2



VR-
x 8

Code / Código

Qty / Qté / Cant.

Adjustement / Ajustement / Ajuste

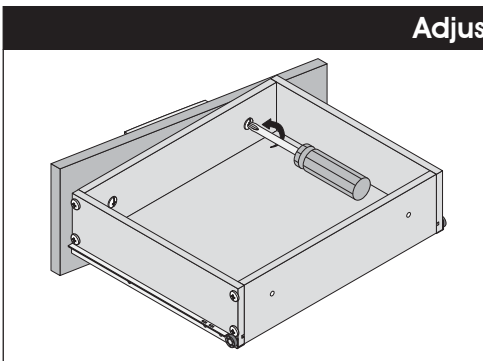

After installing drawers into cabinet, adjust drawer fronts and tighten screws -

Après avoir installé les tiroirs dans le meuble, ajustez les devants de tiroirs et resserrez les vis -

Después de instalar los cajones en el mueble, ajuste las partes delanteras de los cajones y vuelva a atornillar a fondo los tornillos -

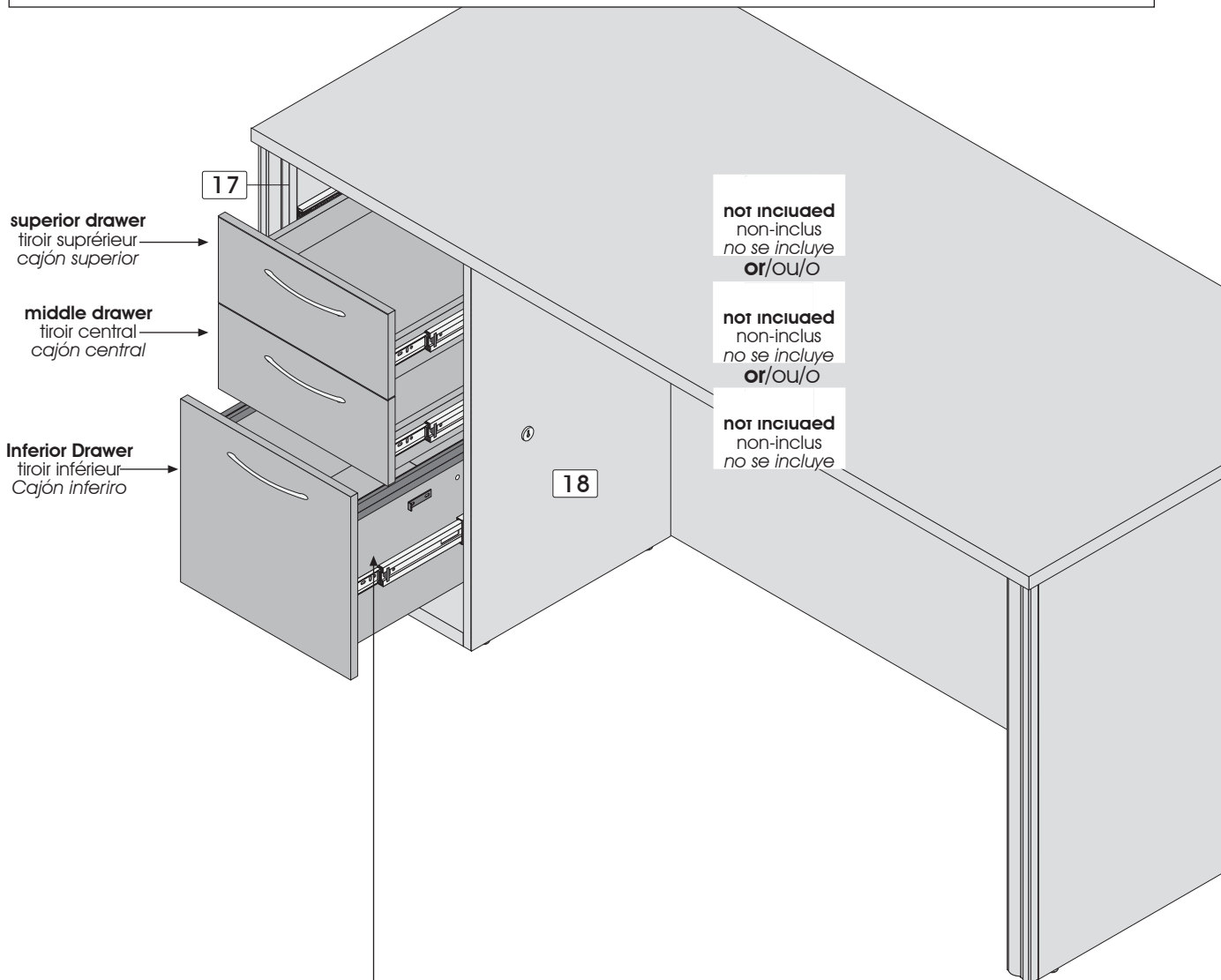

Important/Importante

Ball bearings must be on front part of slider when installing drawers.

Les roulements à billes doivent être sur la partie avant du coulisseau lors de l'installation des tiroirs.

Los cojinetes de bolas deben ubicarse sobre la parte delantera de guía en el momento de instalar los cajones.

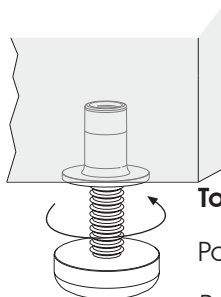
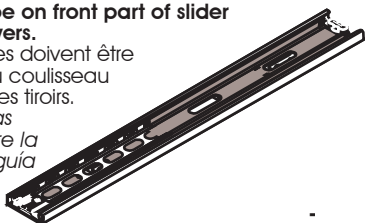

To level your furniture, use leg levelers.

Pour niveler votre meuble utilisez les pattes ajustables.

Para nivelar su mueble utilice las patas ajustables.

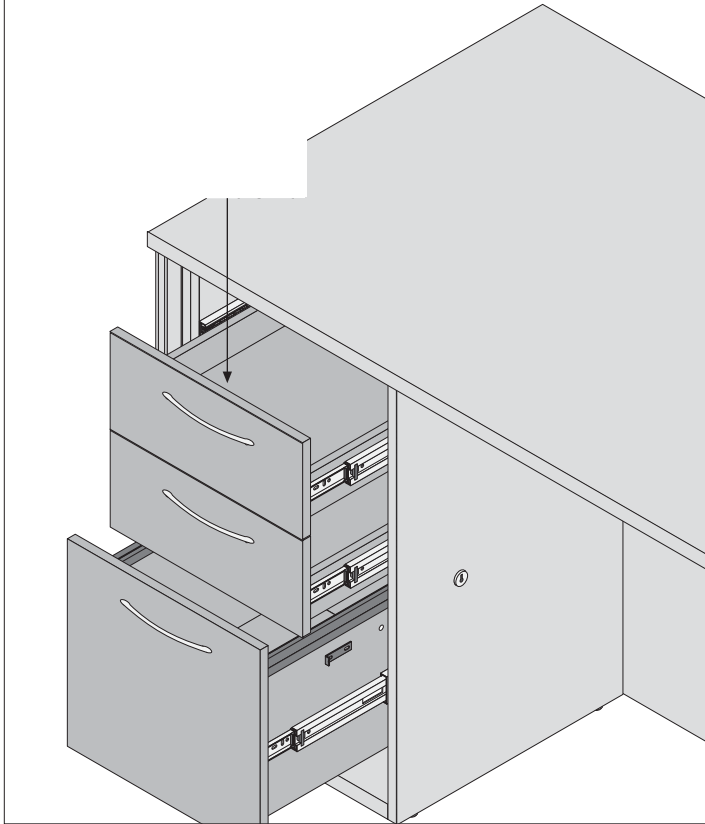
Important/Importante

For future reference and to better serve you, please apply the self-adhesive sticker in an accessible space such as inside a drawer.

Pour mieux vous servir en cas de besoin, veuillez apposer l'autocollant dans un endroit facilement accessible tel que l'intérieur d'un tiroir.

Para uno mejor servicio en caso de necesidad, poner la etiqueta en un lugar de fácil acceso como por ejemplo al interior de un cajón.

PRODUCT CARE / ENTRETIEN DU PRODUIT / MANTENIMIENTO DEL PRODUCTO

Avoid placing the furniture in the sunlight or near a source of heat. Use a soft dry cloth for dusting. To clean heavy dirt, use a cloth dipped in a solution of mild detergent and water. Avoid leaving wet objects on the surface or using commercial chemical cleaning products.

Évitez d'exposer le meuble au soleil ou près de toute source de chaleur. Pour le nettoyage, utilisez un chiffon doux et sec. Pour la grosse saleté, utilisez un chiffon humidifié avec un peu de détergent dilué dans l'eau. Évitez de laisser des objets mouillés sur la surface de votre meuble ou d'utiliser des nettoyants chimiques.

Evite exponer el mueble al sol o las fuentes de calor. Para limpiarlo, utilice un paño suave y seco. Para limpiar las manchas rebeldes, utilice un trapo húmedo con un poco de detergente diluido en agua. No deje objetos mojados encima del mueble ni utilice limpiadores que contengan productos químicos. química.

CONGRATULATIONS! YOU ARE NOW THE OWNER OF A QUALITY PRODUCT
FÉLICITATIONS! VOUS AVEZ MAINTENANT EN VOTRE POSSESSION UN PRODUIT DE QUALITÉ
FELICITACIONES! AHORA ES USTED DUEÑO DE UN PRODUCTO DE CALIDAD.

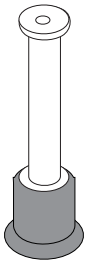

You are at a step of hardware installation and some H- are missing:
Before calling to order your missing bolts (H- please make sure you have not installed any bolts (H- in the wrong place. To remove a bolt (H- which is not in the correct place, please refer to your instruction manual.

Vous êtes à une étape d'installation de quincaillerie et il vous manque des H- :
Avant d'appeler pour commander des boulons (H- assurez-vous de ne pas avoir installé des boulons (H- au mauvais endroit. Pour enlever un boulon (H- mal situé, consultez le feuillet d'instructions.

*Usted está en alguna etapa de la instalación de quincallas y le faltan las H- :
Antes de llamar para pedir los pernos (H- asegúrese de que no los haya instalado en el lugar equivocado.
Para retirar un perno (H- mal puesto, consulte el folleto de instrucciones.*

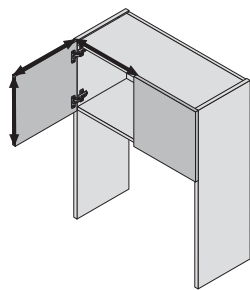
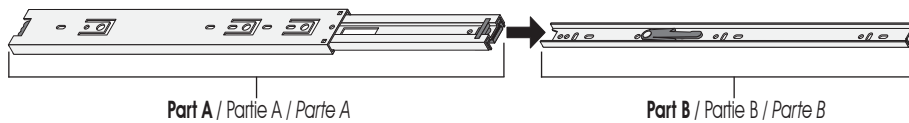

The doors on your furniture are crooked or the space between the doors is uneven:
It is very important to install the hinges and hinge plates on the correct parts while respecting the instruction manual.
For the installation and adjustment of the doors,
)

Les portes de votre meuble sont crochées ou l'espace qui les sépare est inégal :
Il est important d'installer les pentures et les plaques sur les bonnes pièces en respectant le feuillet d'instructions. Pour l'installation des portes et leur ajustement, référez-vous à l'étape d'installation des portes dans le feuillet d'instructions ou sur le site internet de

*Las puertas de su mueble están chuecas o el espacio que las separa es desigual :
Es importante instalar las bisagras y las placas sobre las piezas adecuadas respetando el folleto de instrucciones. Para la instalación de las puertas y su ajuste, consulte la etapa de instalación de las puertas en el folleto de instrucciones o en el sitio Internet de*

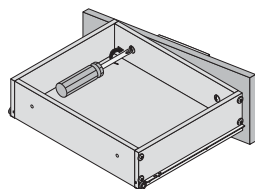

The drawers on your furniture are crooked or the space between the drawers is uneven:
While referring to the section indicating the actual sizes of the screws in your instruction manual , please insure that you are using the correct size screws needed when installing your drawer slides and drawer fronts. They must be installed straight. While installing the drawer front, make sure that the correct side is facing up. For the adjustment of the drawer fronts, please refer to your instruction manual or log on to the

Les tiroirs de votre meuble sont crochés ou l'espace qui les sépare est inégal :
En vous référant au tableau de vis grandeur réelle du feuillet d'instructions, assurez-vous que vous avez utilisé les bonnes vis de l'installation des coulisseaux ainsi que du devant de tiroir et qu'elles sont posées bien droites. Assurez-vous également que le devant du tiroir n'est pas assemblé à l'envers. Référez-vous à l'étape d'ajustement des tiroirs dans le feuillet d'instructions ou sur le site internet de

*Los cajones de su mueble están chuecos o el espacio que los separa es desigual :
Consulte la tabla de tornillos en tamaño real del folleto de instrucciones y asegúrese de que haya utilizado los tornillos adecuados durante la instalación de las guías correderas así como también la parte delantera del cajón y que éstos estén puestos bien derechos. Asegúrese también de que la parte delantera del cajón no esté ensamblada al revés. Consulte la etapa del ajuste de cajones en el folleto de instrucciones o en el sitio Internet de*

