

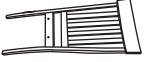

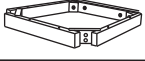





Assembly Instruction

SLAT BACK SIDE CHAIR WITH CUSHION

NO	Parts List		Q'TY
A		Chair Back	1 pce
B		Box Seat	1 pce
C		Cushion	1 pce
D		Front Leg	2 pcs

NO	Hardware List		Q'TY
1		8 x 1" Pan Head Screw	6 pcs
2		M6x 40mm JCBC Bolt	2 pcs
3		M6x70mm JCBC Bolt	8 pcs
4		M6x13mm Lock Washer	10 pcs
5		M6.5x16.5mm Flat Washer	10 pcs
6		M4 x 2.1/2" Allen Key	1 pce

Important Note

Do not use power tool for assembly.
All bolt must fasten either by wrench or Allen Key.



STEP 1 Do not fully tighten the bolt

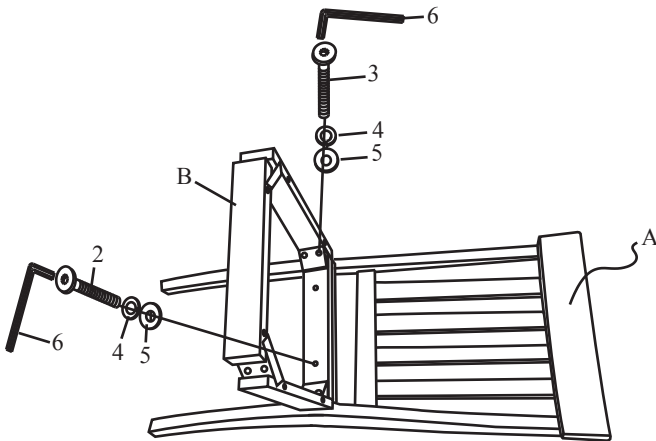

STEP 2 Do not fully tighten the bolt

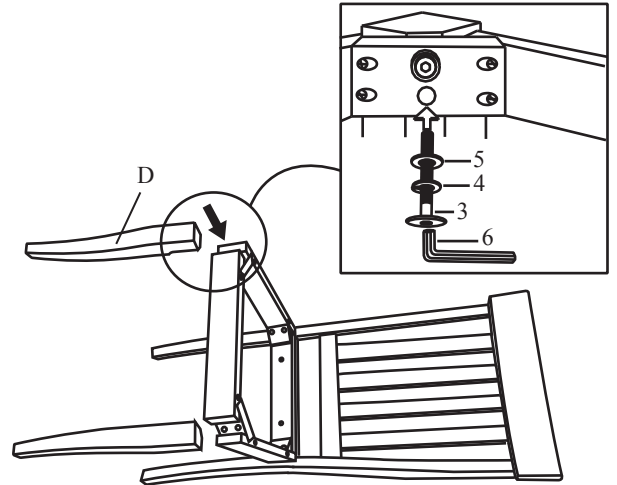

STEP 3

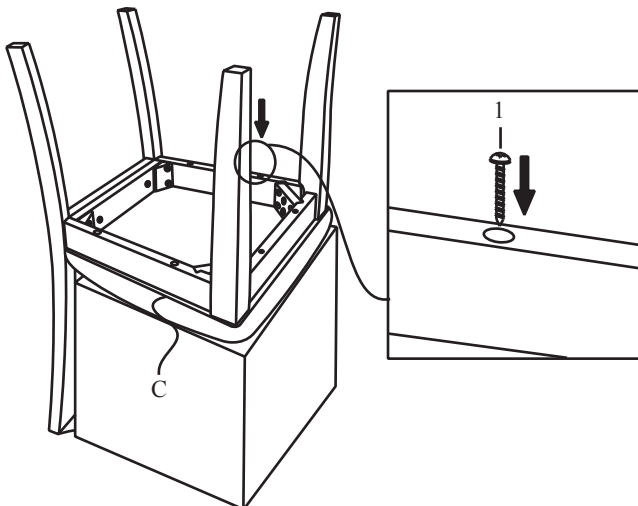

STEP 4

Levelling solution: Loosen each bolt in the seat box (front legs, back corner blocks and back apron) to the point where it can be turned with our fingers. Place the Chair/Stool upright on the floor and make sure Chair/Stool back and seat frame are well connected. Sit in the Chair/Stool, but do not lean against the Chair/Stool back. Gently sway back and forth, left and right. Carefully turn the Chair/Stool upside down, and tighten each bolt. The Chair/Stool will now be levelled.

