

ASSEMBLY INSTRUCTIONS

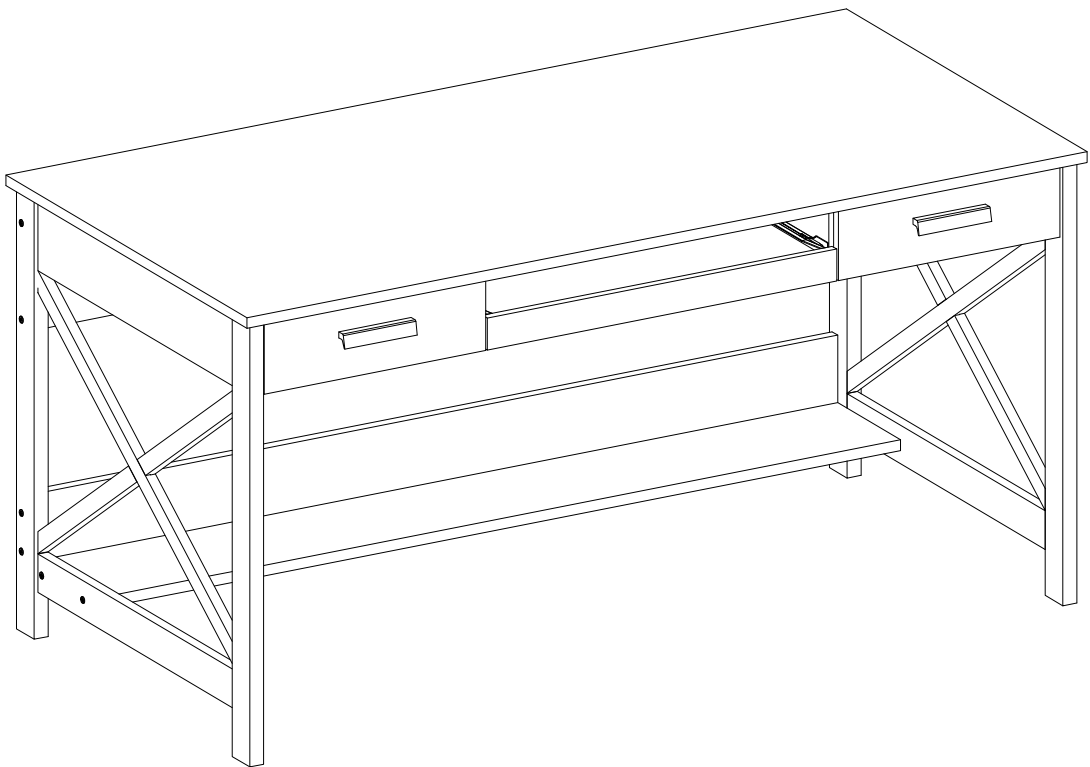

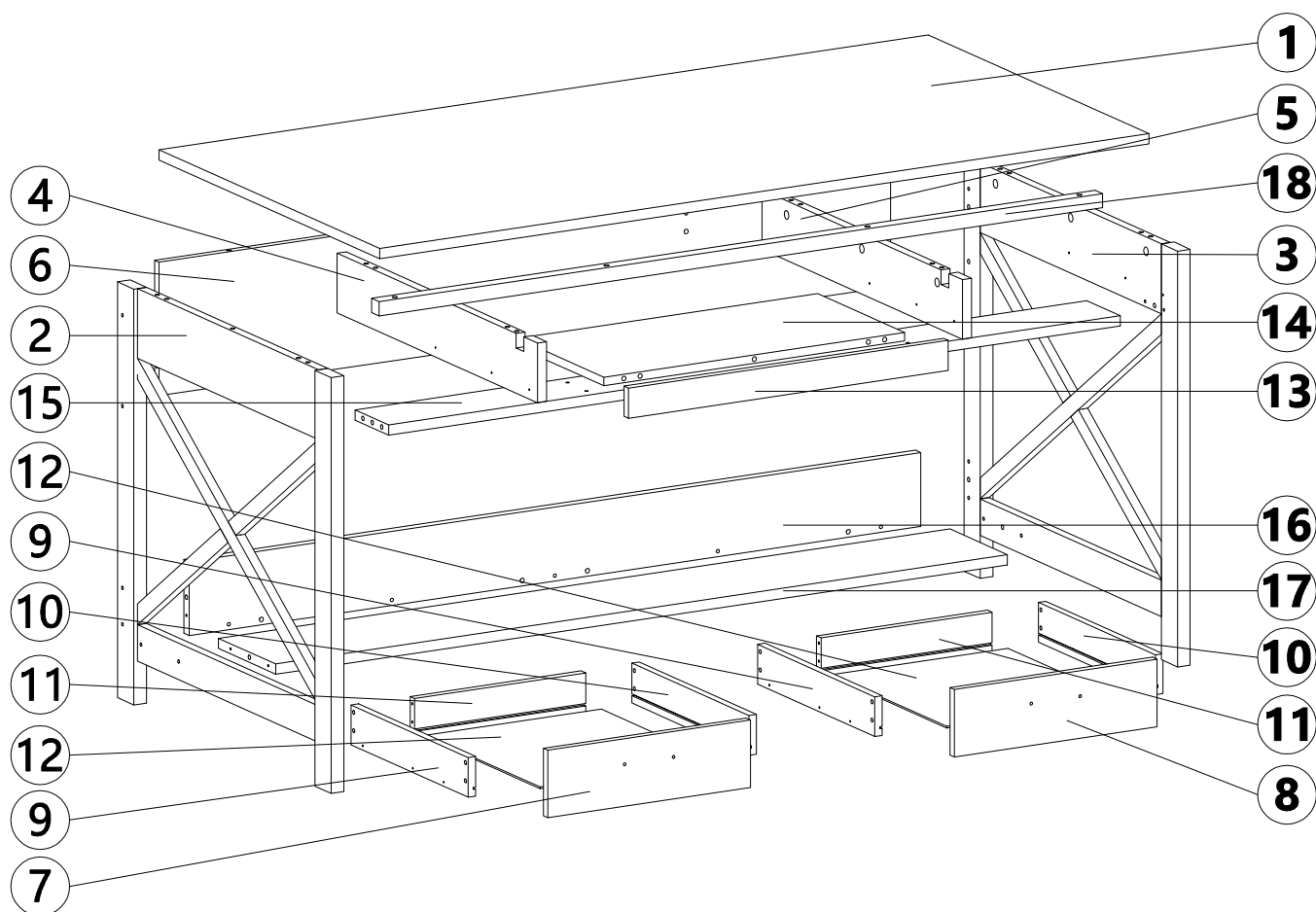

PARTS LIST

① X1	② X1	③ X1	④ X1	⑤ X1
⑥ X1	⑦ X1	⑧ X1	⑨ X2	⑩ X2
⑪ X2	⑫ X2	⑬ X1	⑭ X1	⑮ X1
⑯ X1	⑰ X1	⑱ X1		

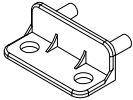
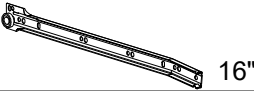
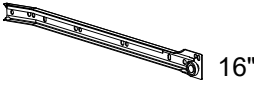
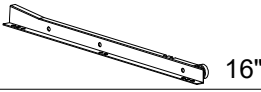
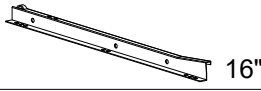
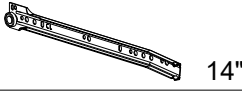
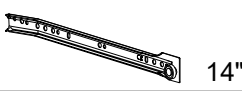
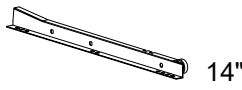
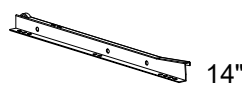
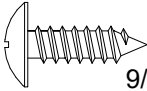
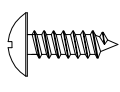
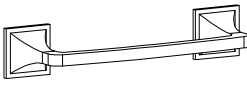
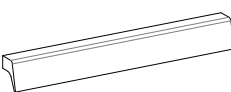
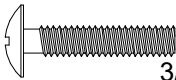
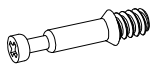

HARDWARE LIST

Name	Part	Qty.	Spare
A		4	
B	 16"	2	
C	 16"	2	
D	 16"	2	
E	 16"	2	
F	 14"	1	
G	 14"	1	
H	 14"	1	
I	 14"	1	
J	 9/16" Screw	8	
K	 1/2" Screw	12	2
L	A K 1 7 0 1 	2	
	A K 1 7 3 4 		
M	 3/4" Bolt	4	1
N		22	1

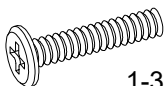
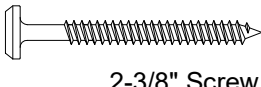
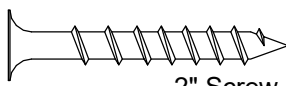
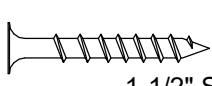
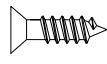
Name	Part	Qty.	Spare
O		22	1
P		30	1
Q	 1-3/8" Bolt	4	
R	 2-3/8" Screw	12	
S	 2" Screw	11	1
T	 1-1/2" Screw	8	
U	 1/2" Screw	30	3

STEP 1

A x 4pcs

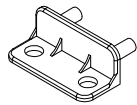

J x 8pcs

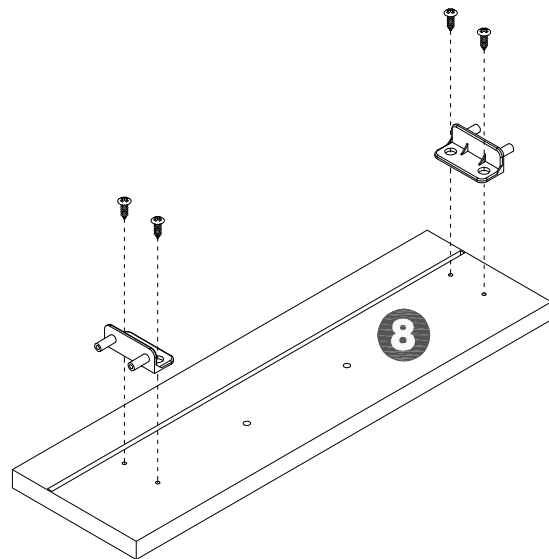
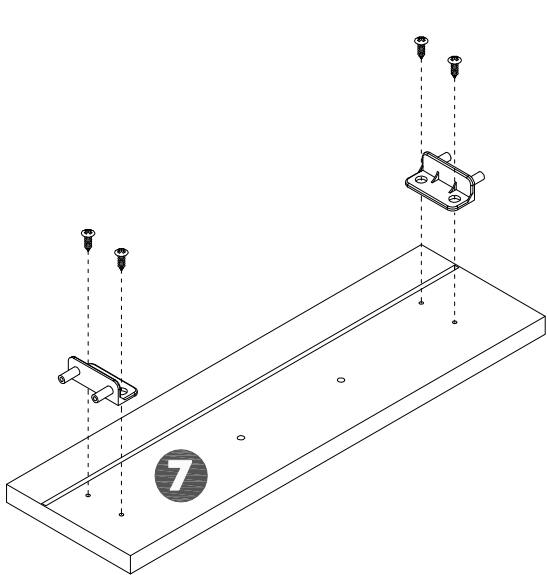
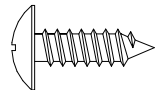

STEP 2

D x 2pcs

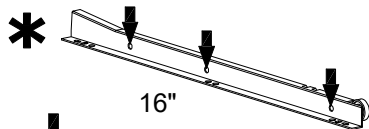

E x 2pcs

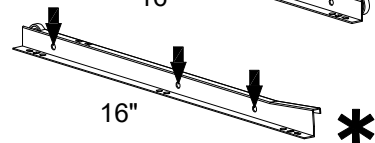

U x 12pcs

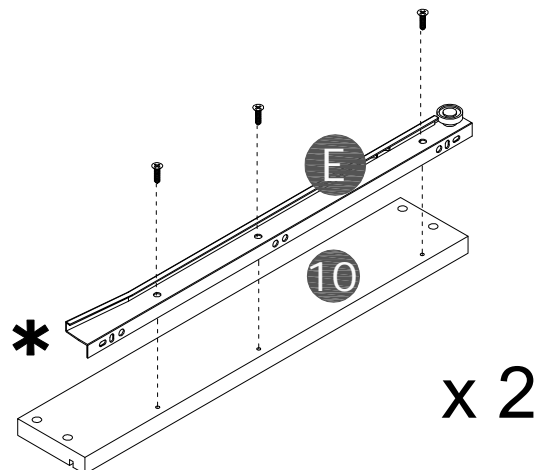
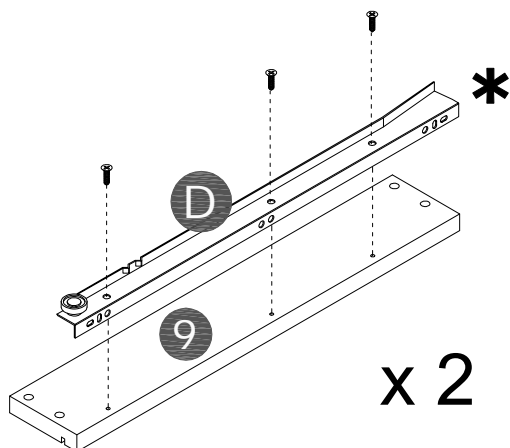
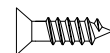

STEP 3

K x 8pcs 

T x 8pcs 

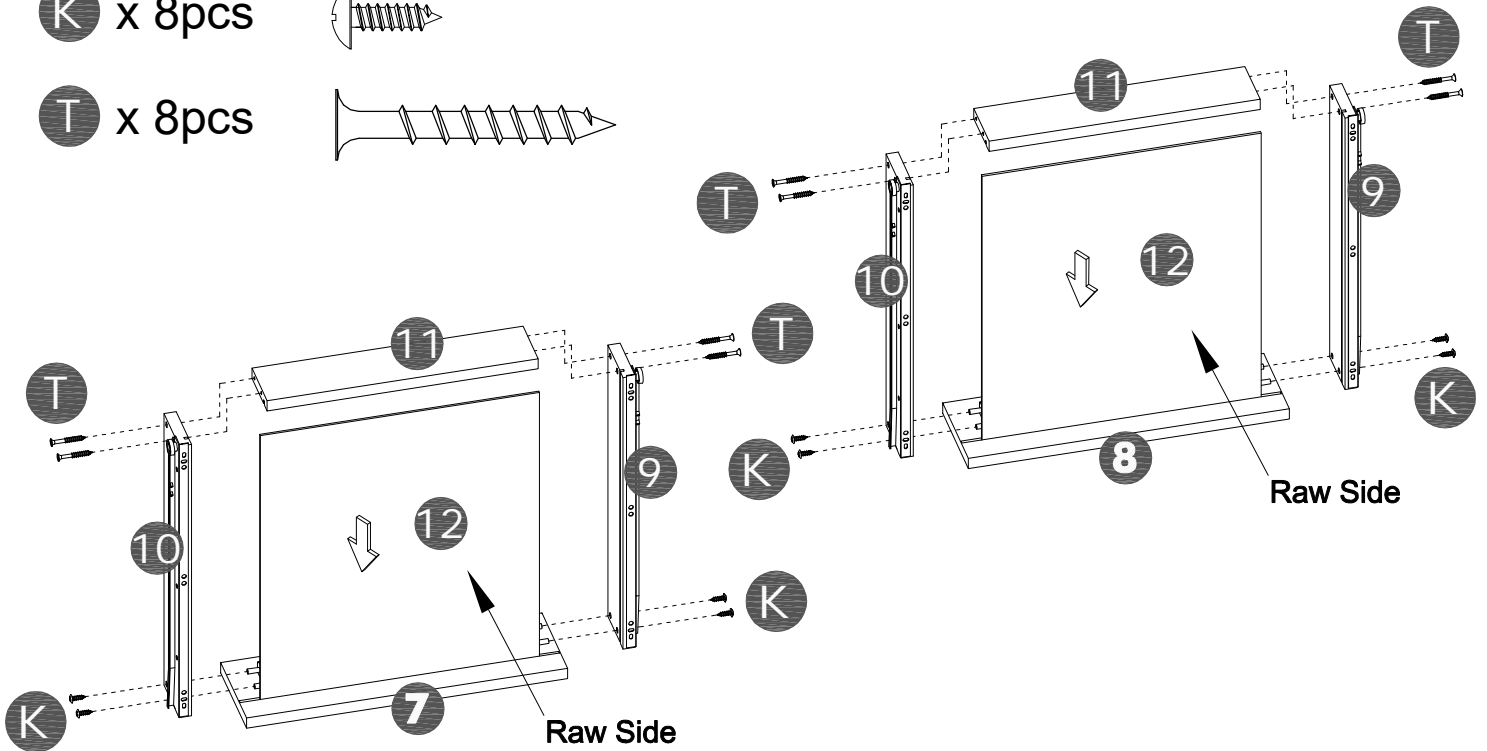

STEP 4

AK1701

L x 2pcs 

M x 4pcs 

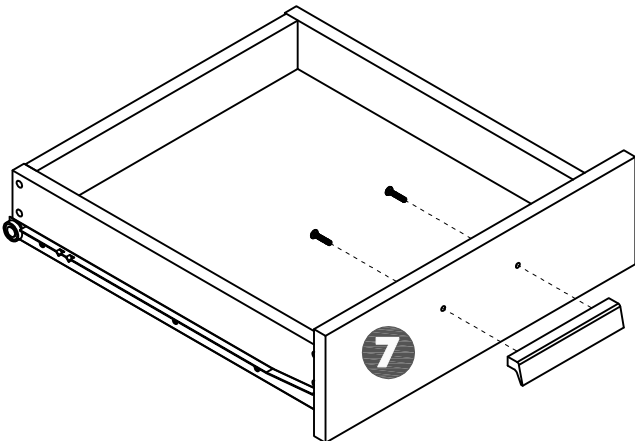

AK1734

L x 2pcs 

M x 4pcs 

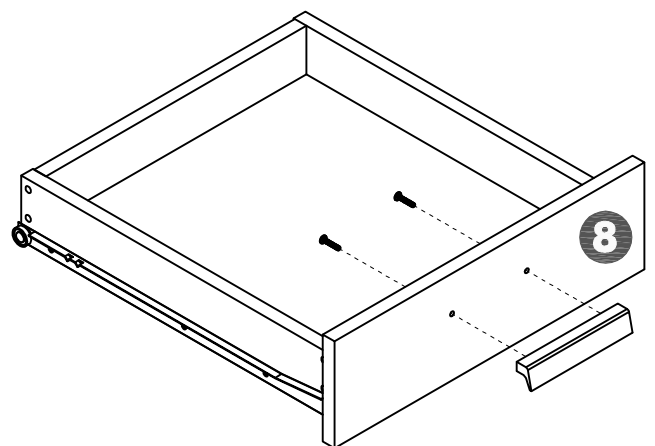

STEP 5

K x 4pcs 

N x 3pcs 

P x 2pcs 

H x 1pc 

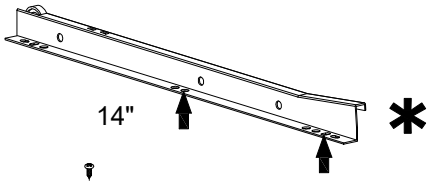
I x 1pc 

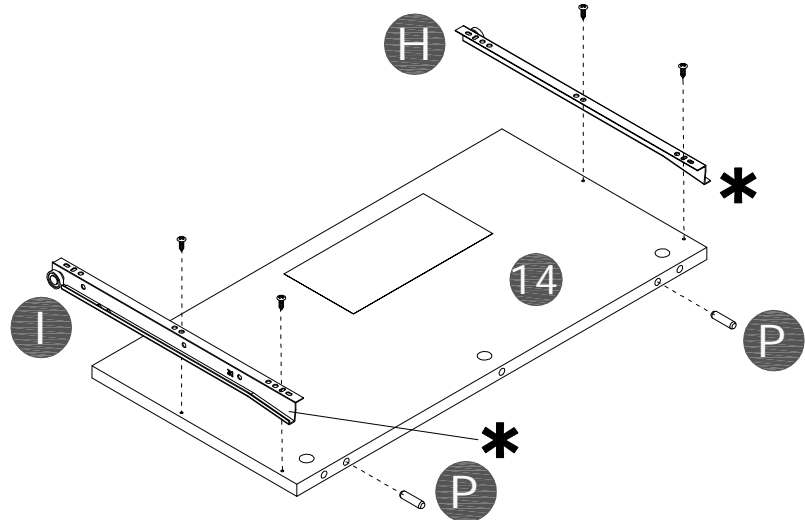
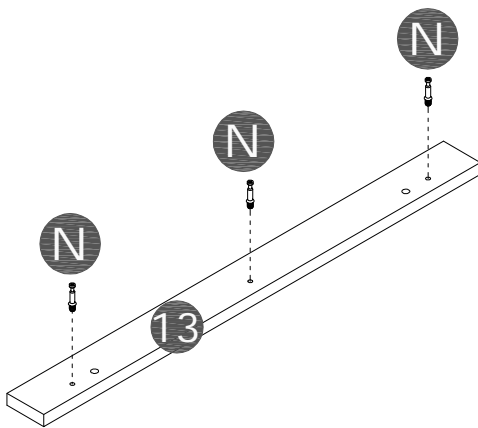

STEP 6

O x 3pcs 

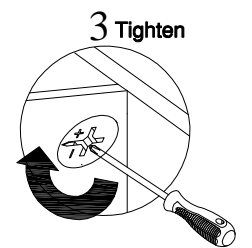
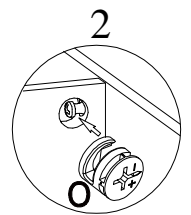
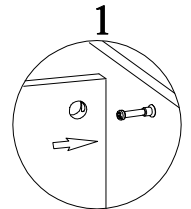
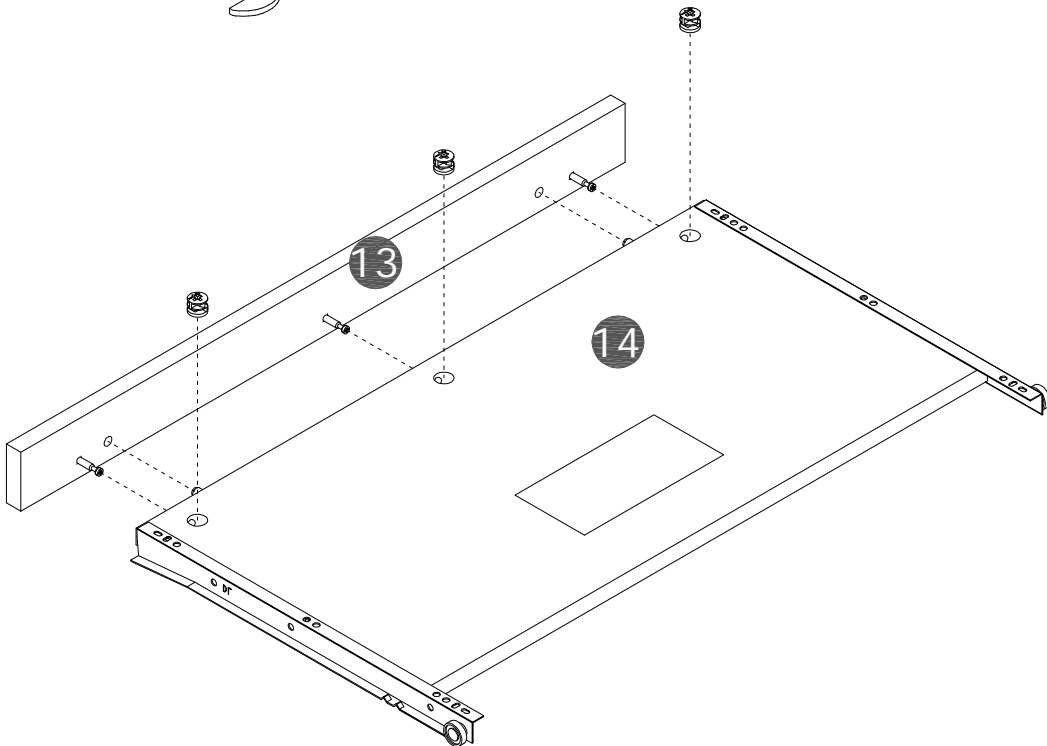

STEP 7

B x 1pc

C x 1pc

G x 1pc

F x 1pc

P x 16pcs



U x 12pcs

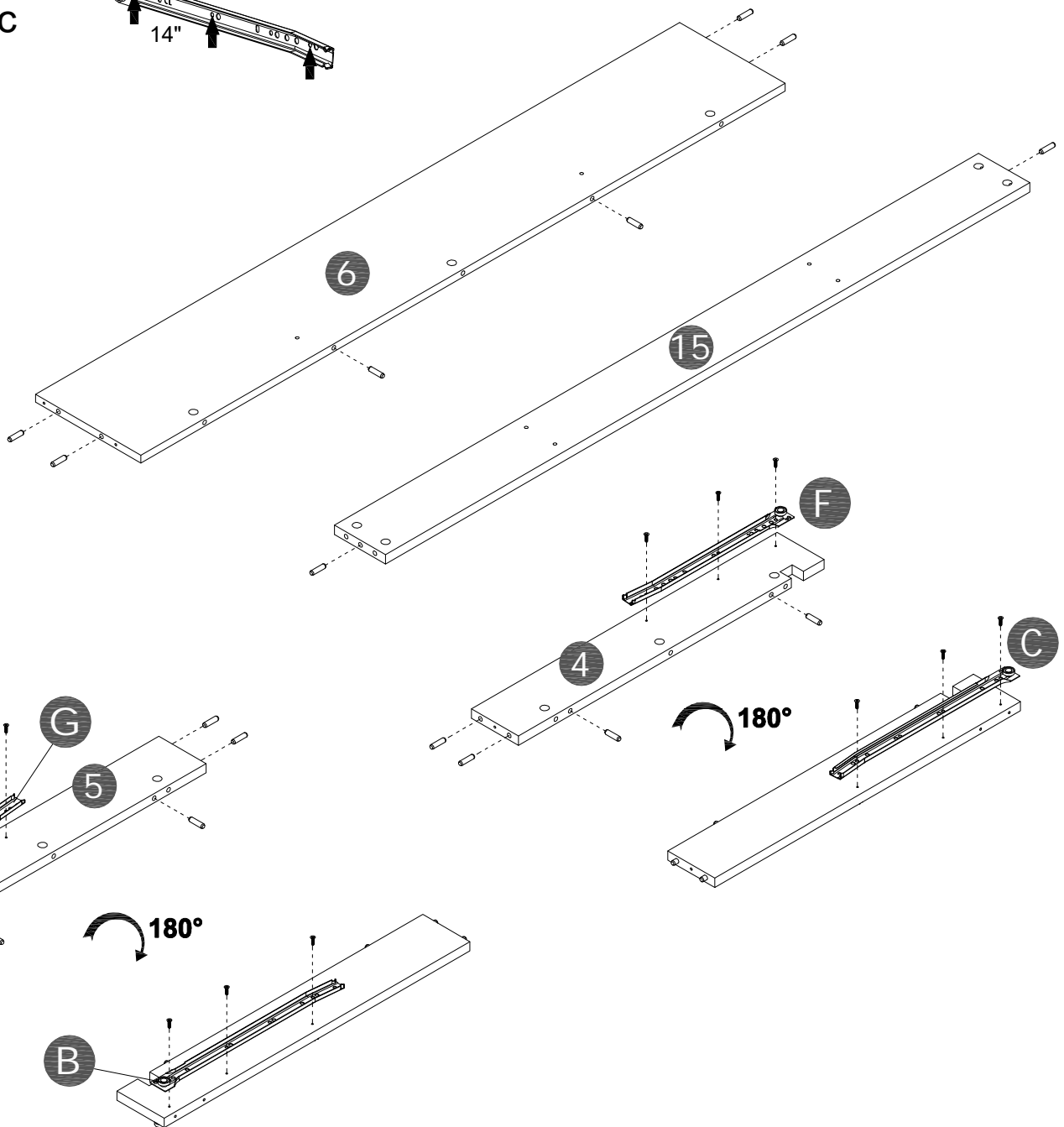
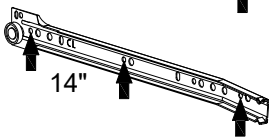
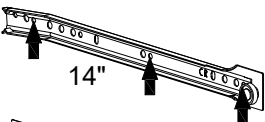
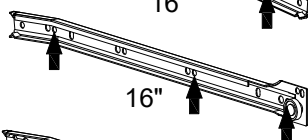
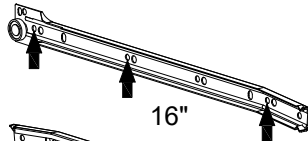
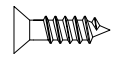

STEP 8

Ⓢ x 4pcs

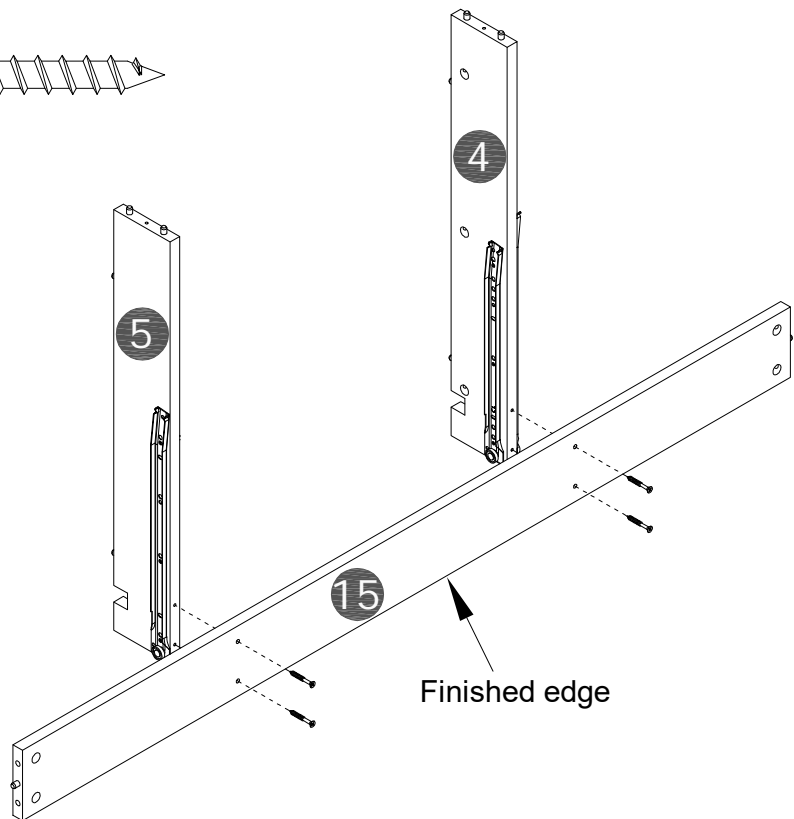
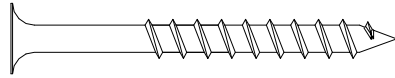

STEP 9

Ⓢ x 2pcs

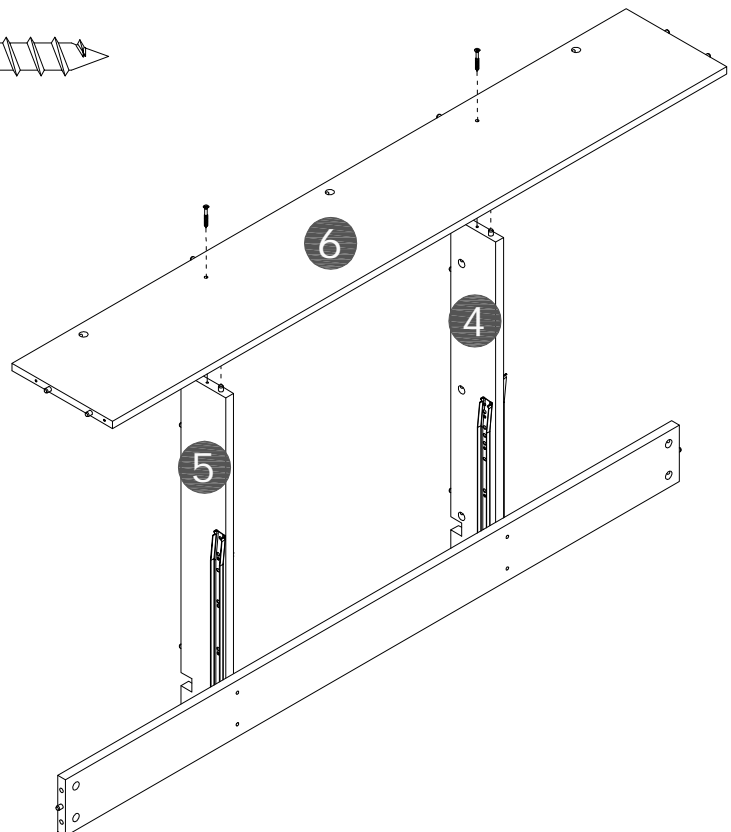
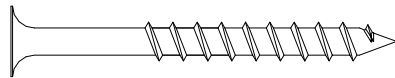

An assistant is required.

STEP 10

P x 12pcs



N x 4pcs

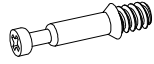

B x 1pc

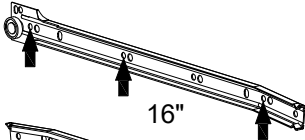

C x 1pc

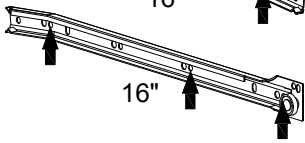

U x 6pcs

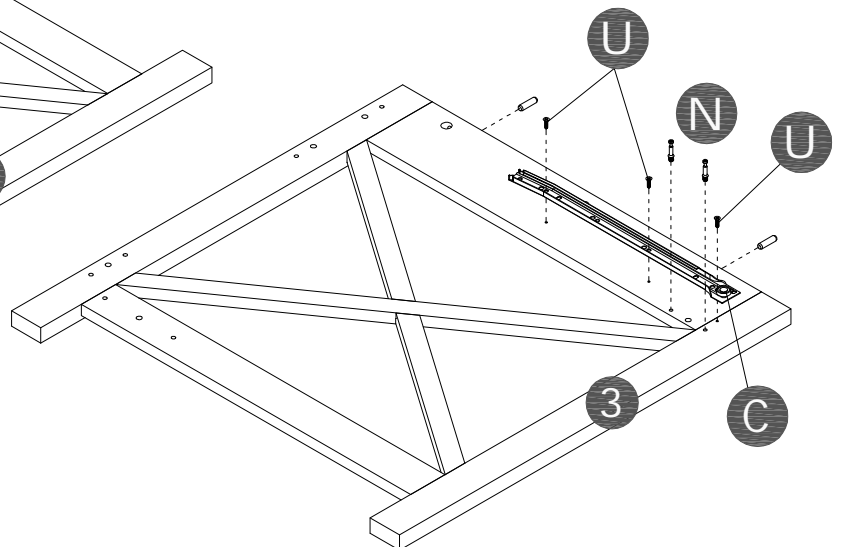
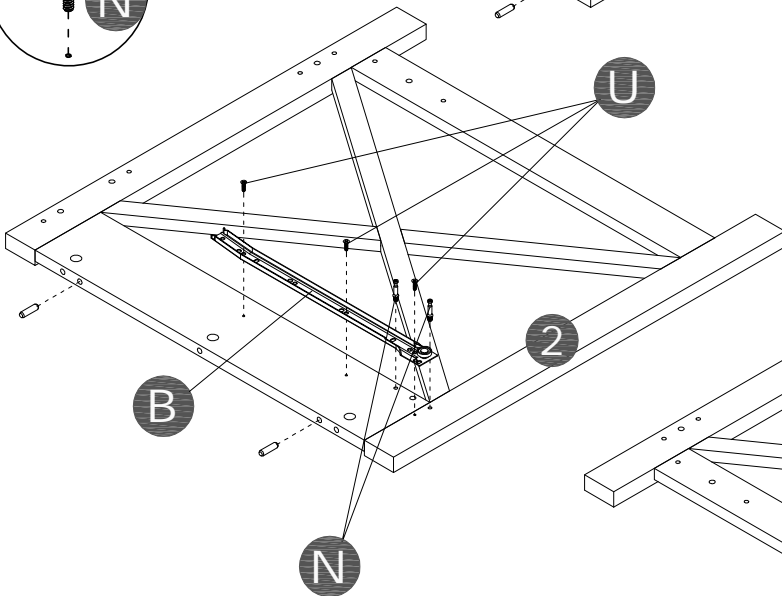
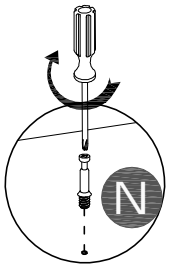
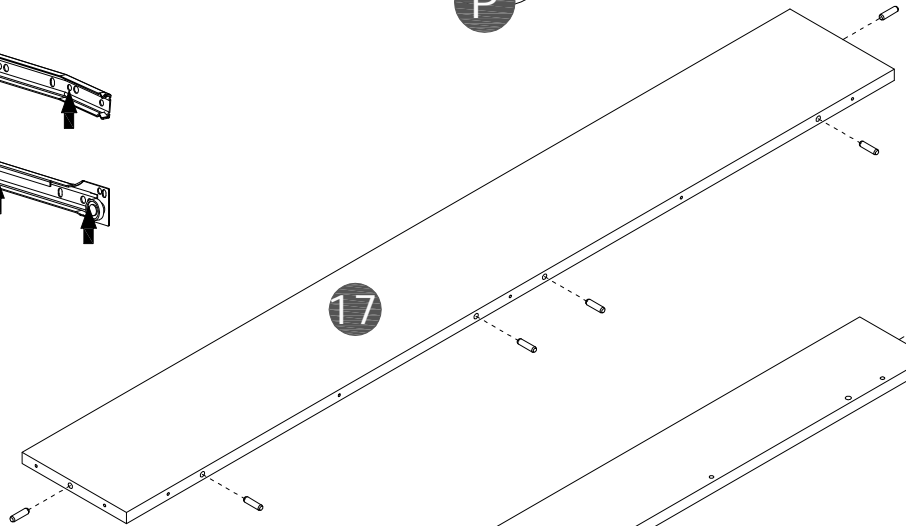
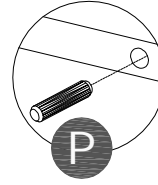
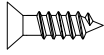

STEP 11

S x 5pcs

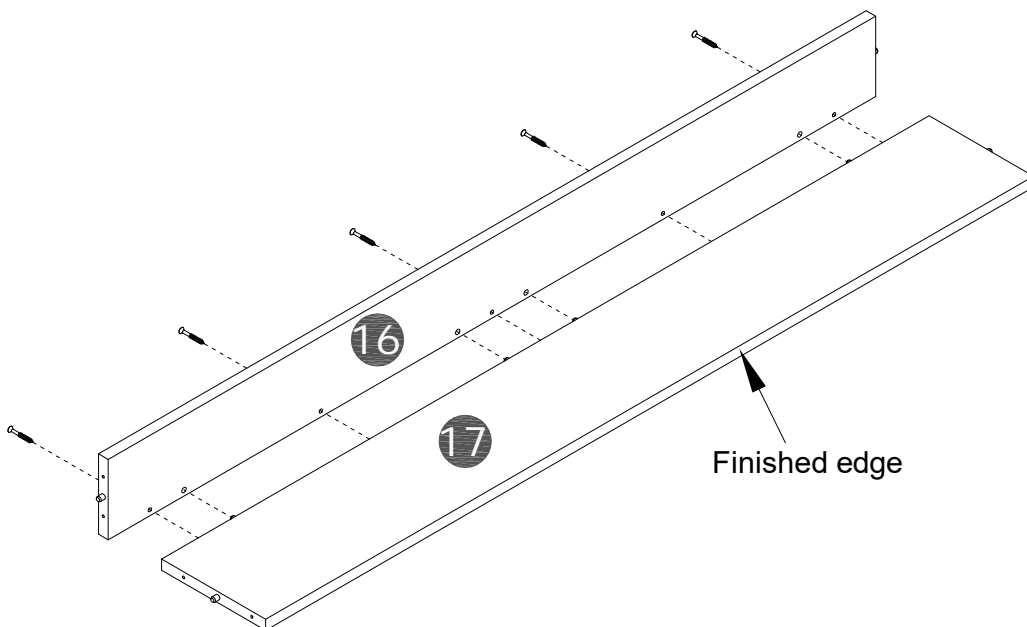
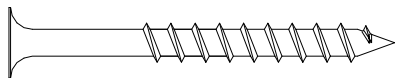

STEP 12

N x 15pcs

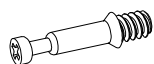

O x 4pcs

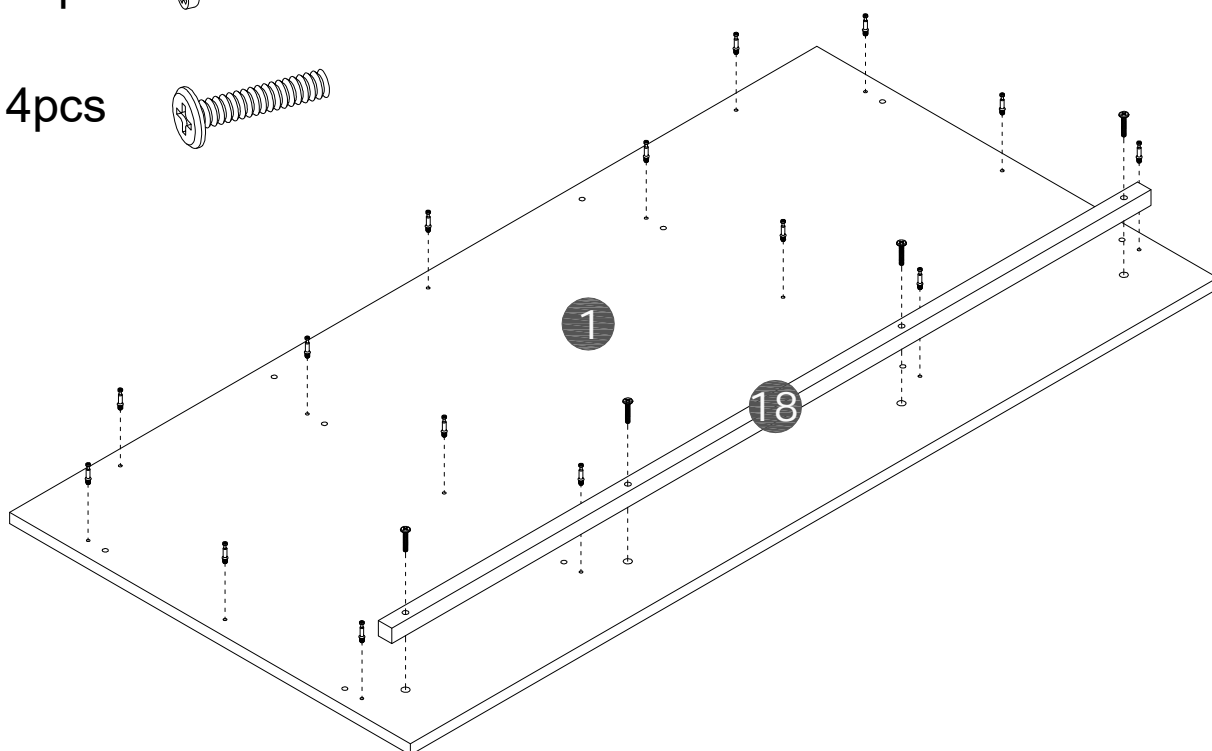
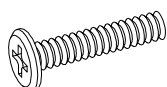

STEP 13

○ x 4pcs



Ⓜ x 12pcs

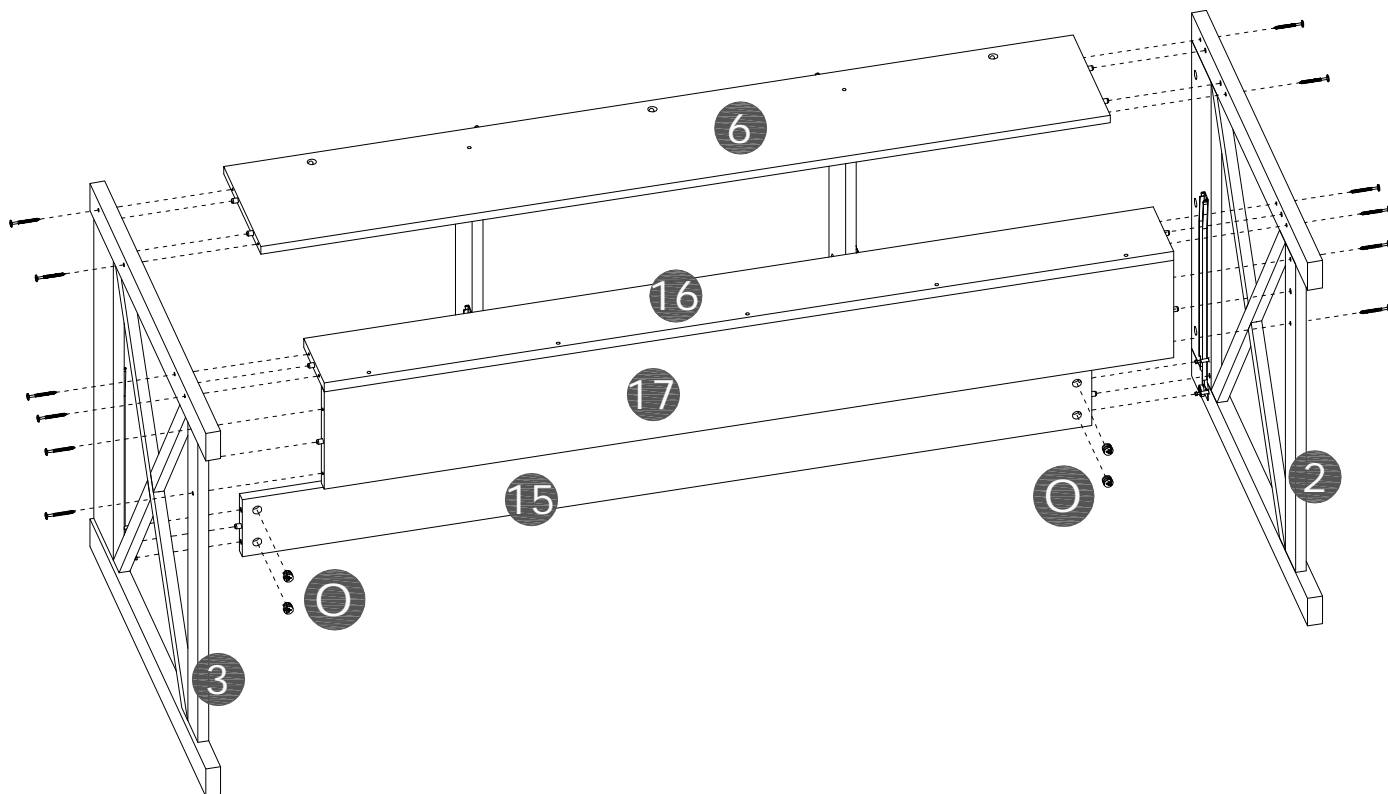
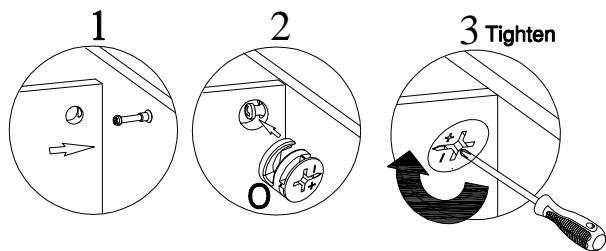
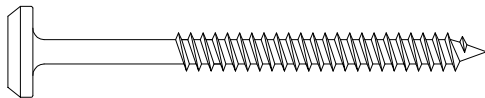

An assistant is required.

STEP 14

⊙ x 15pcs

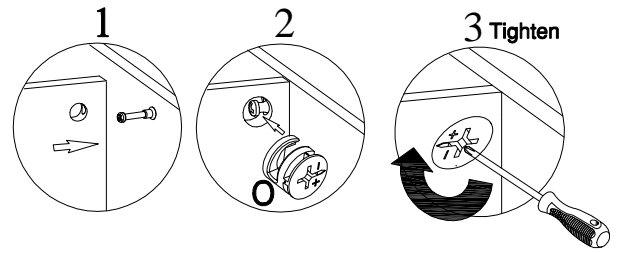

With assistant carefully stand unit up.

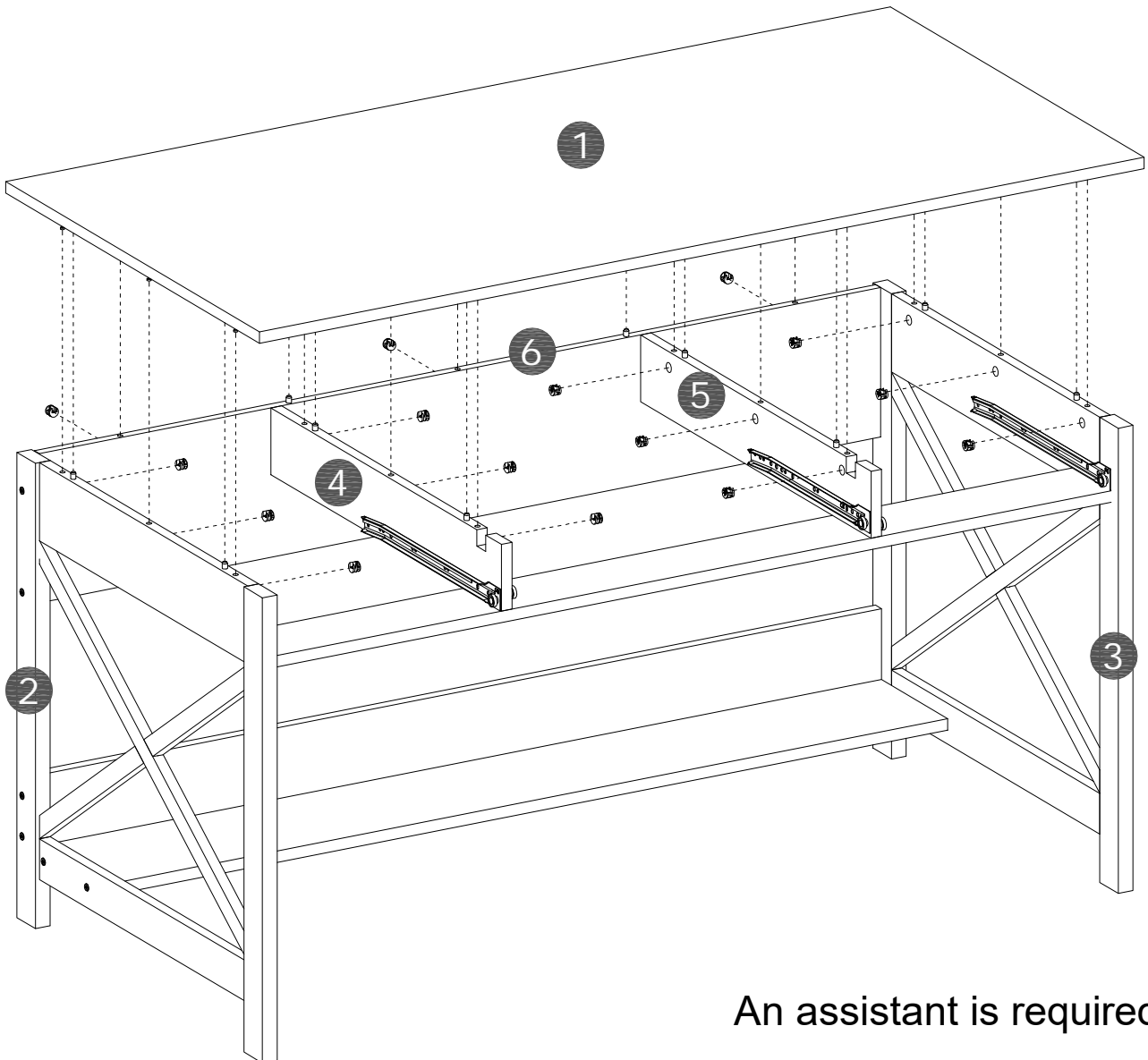

An assistant is required.

STEP 15

- Move unit to final location.
- Adjust drawer fronts as shown below.

- Step1--Loosen screws on back of drawer front brackets as shown.
- Step2--Position drawer front as required.
- Step3--Tighten screws while holding drawer front in position.

STEP 1.

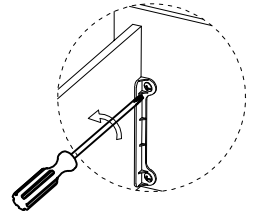

STEP 2.

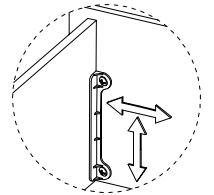

STEP 3.

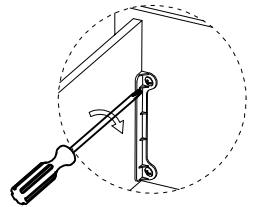

DRAWER FRONT VIEW

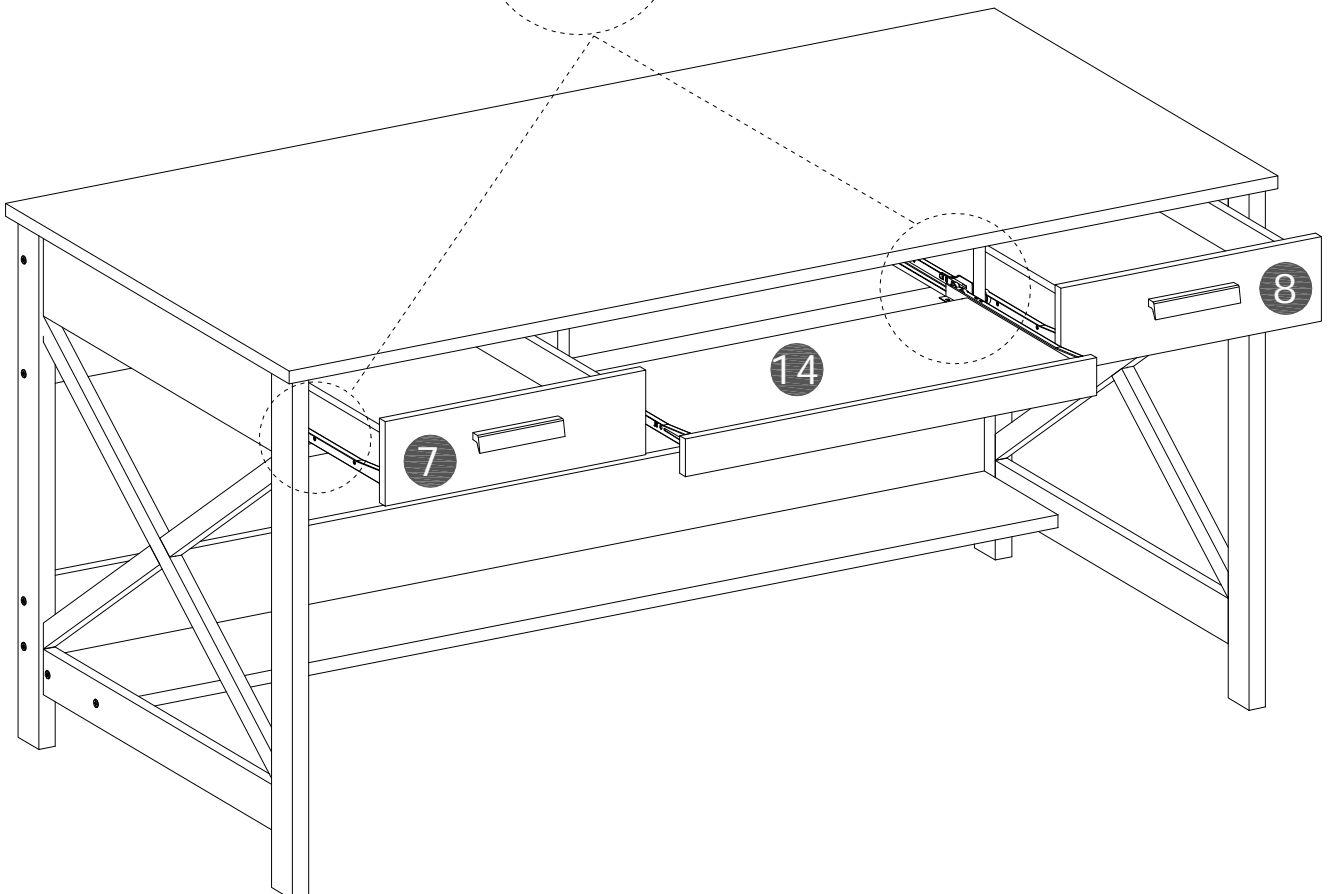
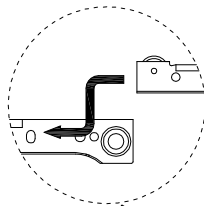
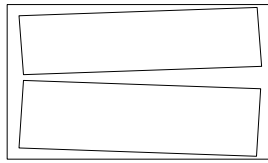
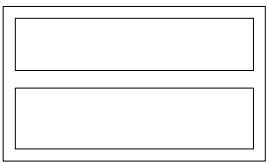

Maximum weight capacities

