

ASSEMBLY INSTRUCTIONS



Fine Furniture for every stage of life

Dining Table

ASSEMBLY INSTRUCTIONS

ASSEMBLY TIPS:

1. Remove hardware from box and sort by size.
2. Please check to see that all hardware and parts are present prior to start of assembly.
3. Please follow attached instructions in the same sequence as numbered to assure fast & easy assembly.



WARNING!





1. Don't attempt to repair or modify parts that are broken or defective. Please contact the store immediately.
2. This product is for home use only and not intended for commercial establishments.

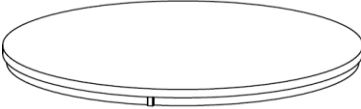

ASSEMBLY TIME

30 MINUTES

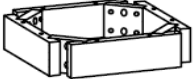
PARTS IDENTIFICATION

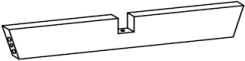
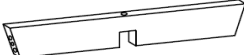
A	TOP		1PC
B	UPPER TOP SUPPORT		1PC
C	LOWER TOP SUPPORT		1PC
D	APRON		1PC
E	LEG		4PCS
F	UPPER CROSSBAR		1PC
G	LOWER CROSSBAR		1PC

NOTE:

Phillips head screw driver is required in the assembly process; however, manufacturer does not provide this item.

ASSEMBLY INSTRUCTIONS

ASSEMBLY TIPS:













1. Remove hardware from box and sort by size.
2. Please check to see that all hardware and parts are present prior to start of assembly.
3. Please follow attached instructions in the same sequence as numbered to assure fast & easy assembly.

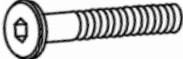

WARNING!

1. Don't attempt to repair or modify parts that are broken or defective. Please contact the store immediately.
2. This product is for home use only and not intended for commercial establishments.

HARDWARE IDENTIFICATION

1	SMALL ALLEN WRENCH (M4 x 100mm - BLK)		1PC
2	BOLT 1 (M6 x 40mm - RBW)		5PCS
3	BOLT 2 (M6 x 120mm - BLK)		8PCS
4	SMALL LOCK WASHER (M6 - RBW)		13PCS
5	SMALL FLAT WASHER (M6 - RBW)		4PCS
6	BIG ALLEN WRENCH (M5 x 65mm - BLK)		1PC
7	BOLT 3 (M8 x 70mm - RBW)		8PCS
8	BIG LOCK WASHER (M8 - RBW)		8PCS
9	BIG FLAT WASHER (M8 - RBW)		8PCS
10	PLASTIC DOWEL (M8 x 30mm - BLK)		4PCS
11	WAFER HEAD SCREW (M4 x 25mm - BLK)		16PCS
12	TRIM		4PCS

NOTE:

Phillips head screw driver is required in the assembly process; however, manufacturer does not provide this item.

ASSEMBLY INSTRUCTIONS
STEP 1

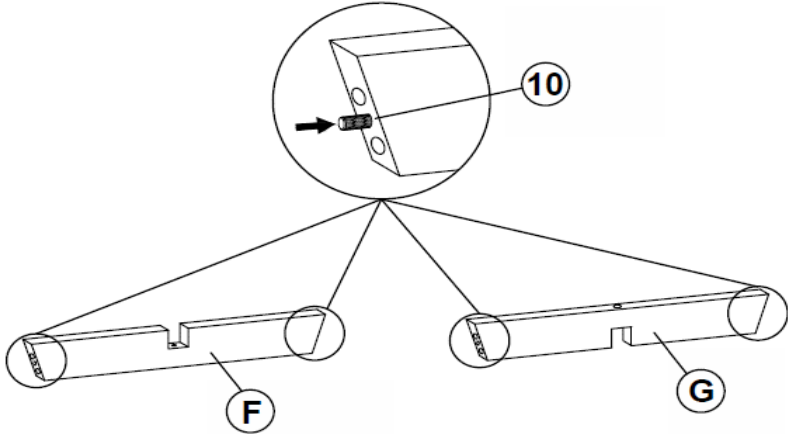

STEP 2

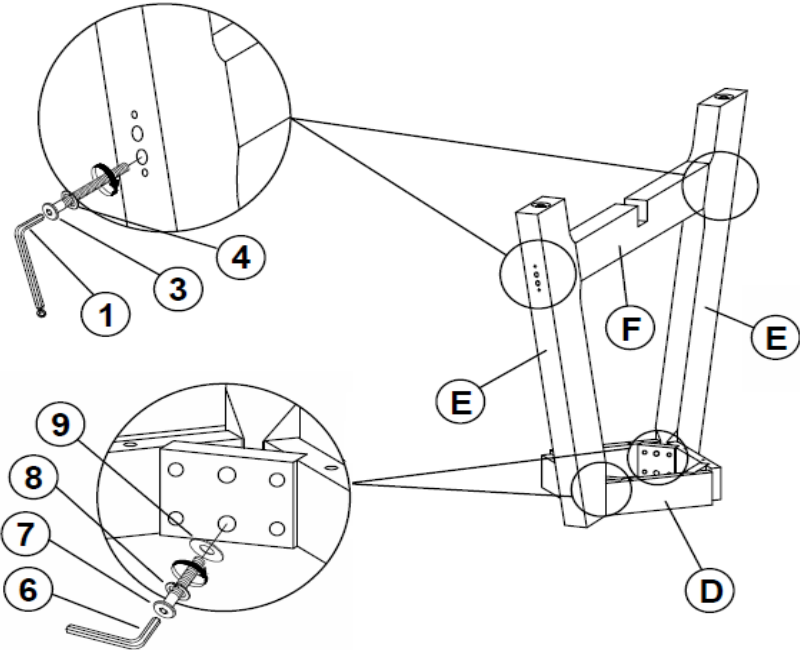

STEP 3

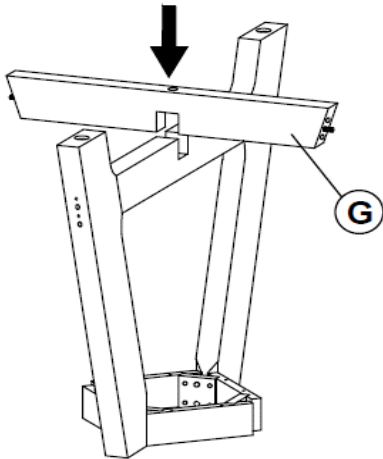

ASSEMBLY INSTRUCTIONS

STEP 4

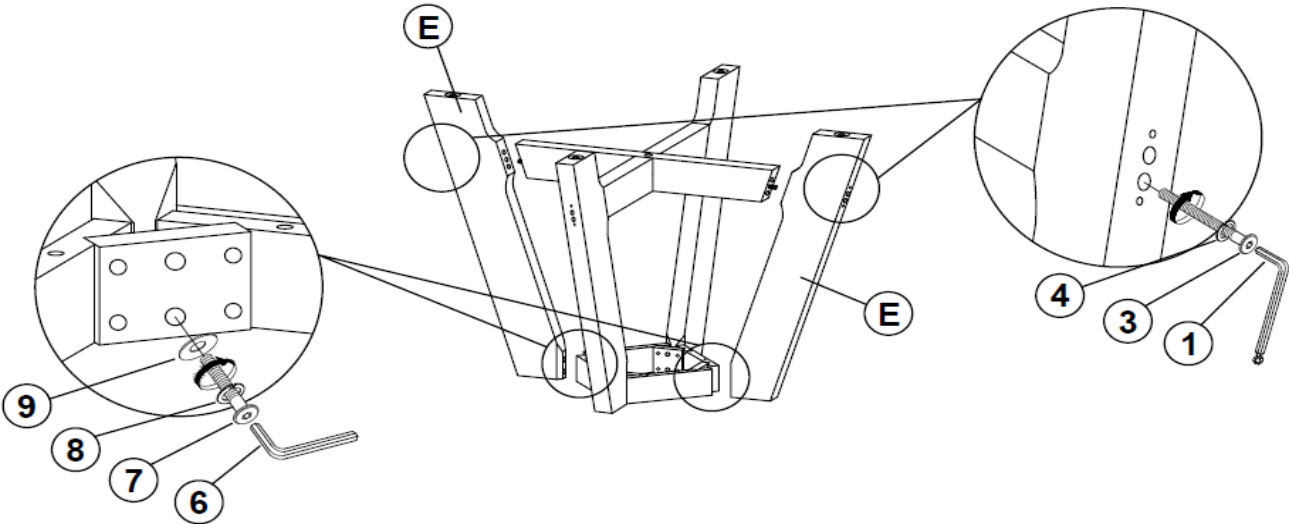

STEP 5

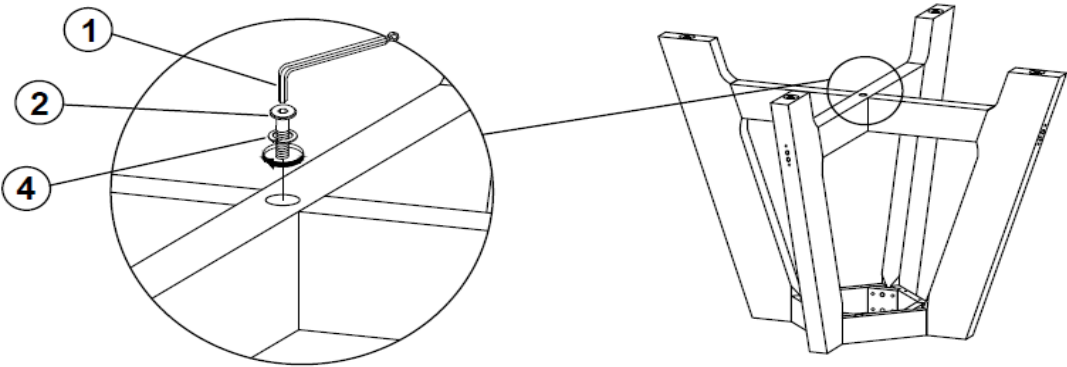

STEP 6

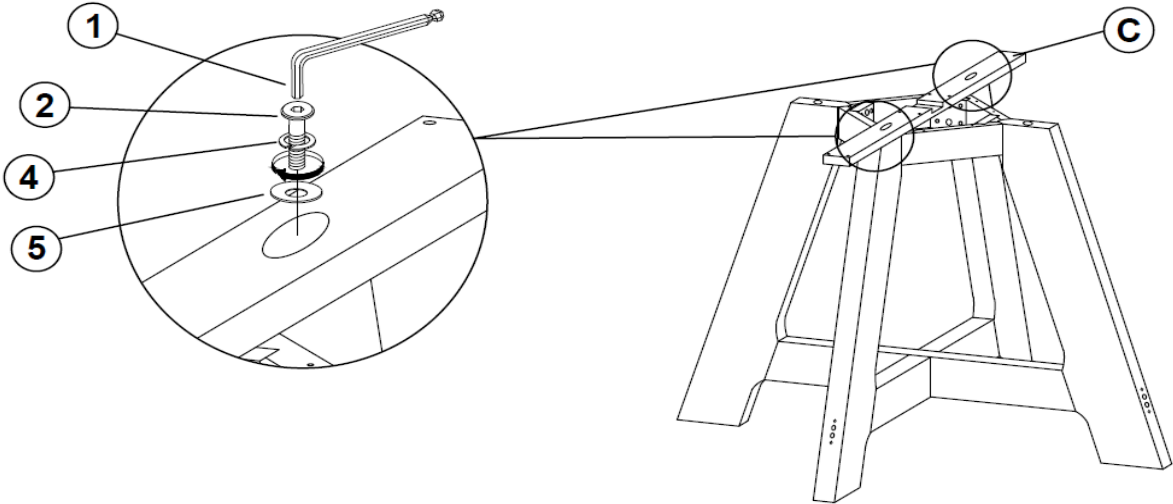

ASSEMBLY INSTRUCTIONS

STEP 7

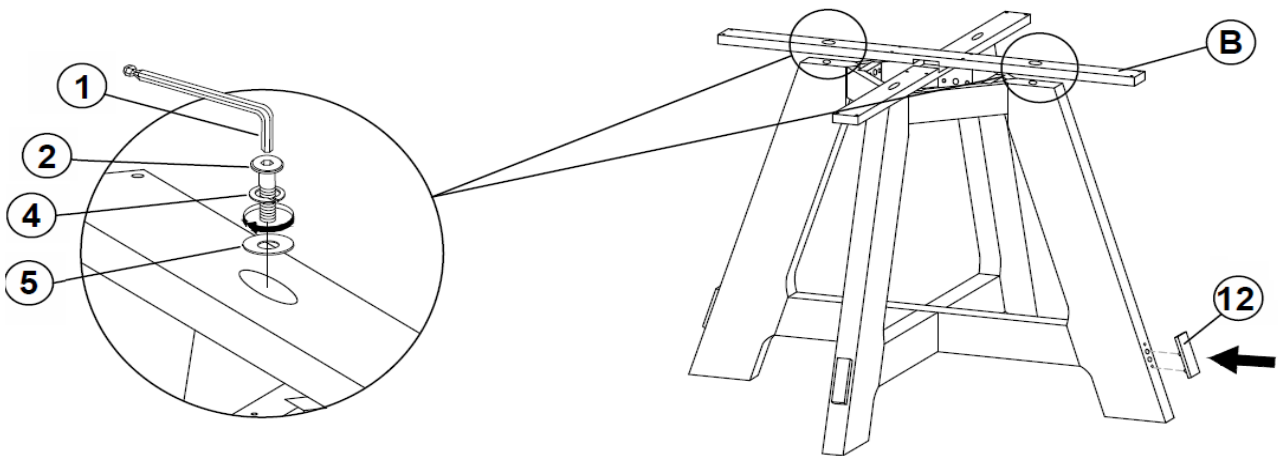

STEP 8

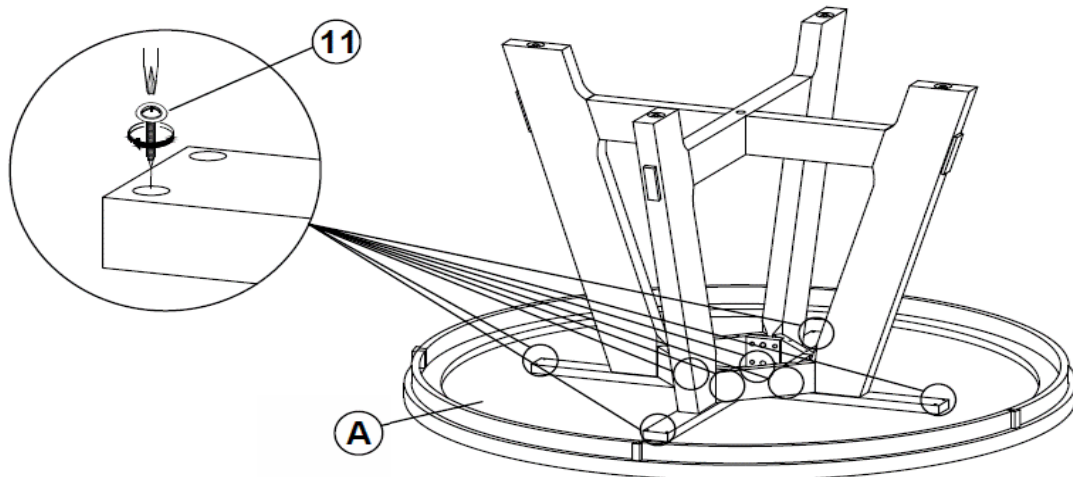

STEP 9

COMPLETE

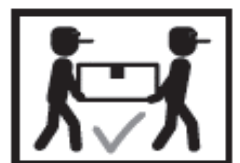
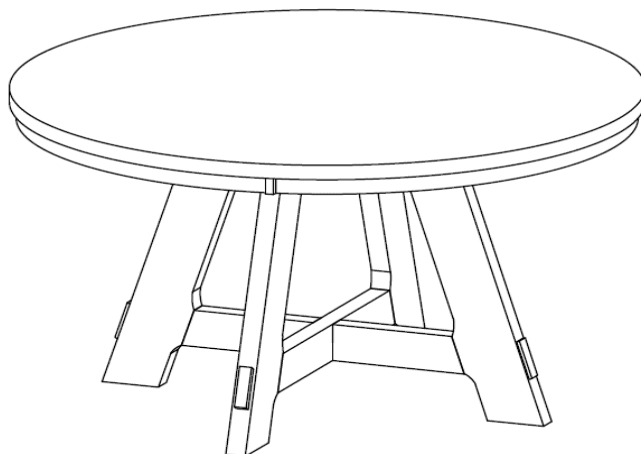

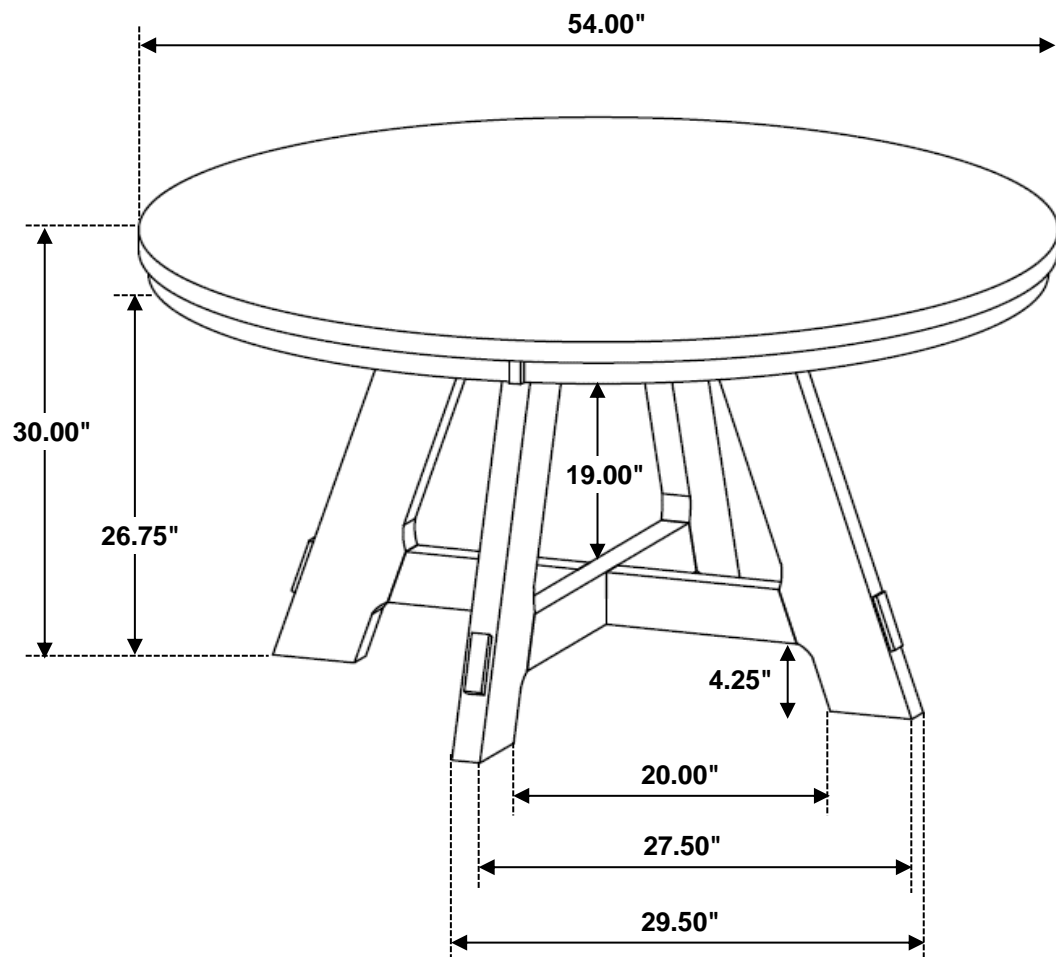

Note: Dimension tolerance $\pm 5\%$

ASSEMBLY INSTRUCTIONS



Fine Furniture for every stage of life

Side Chair

ASSEMBLY INSTRUCTIONS

ASSEMBLY TIPS:

1. Remove hardware from box and sort by size.
2. Please check to see that all hardware and parts are present prior to start of assembly.
3. Please follow attached instructions in the same sequence as numbered to assure fast & easy assembly.



WARNING!





1. Don't attempt to repair or modify parts that are broken or defective. Please contact the store immediately.
2. This product is for home use only and not intended for commercial establishments.

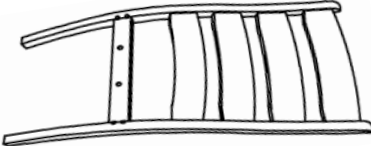
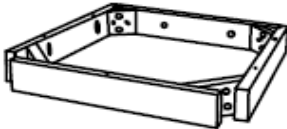

ASSEMBLY TIME

10 MINUTES

PARTS IDENTIFICATION

A	BACK FRAME		1PC
B	SEAT FRAME		1PC
C	SEAT CUSHION		1PC
D	LEFT FRONT LEG		1PC
E	RIGHT FRONT LEG		1PC

NOTE:

Quantities shown are for one chair.

Phillips head screw driver is required in the assembly process; however, manufacturer does not provide this item.

ASSEMBLY INSTRUCTIONS

ASSEMBLY TIPS:





1. Remove hardware from box and sort by size.
2. Please check to see that all hardware and parts are present prior to start of assembly.
3. Please follow attached instructions in the same sequence as numbered to assure fast & easy assembly.

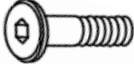
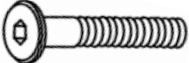

WARNING!

1. Don't attempt to repair or modify parts that are broken or defective. Please contact the store immediately.
2. This product is for home use only and not intended for commercial establishments.

HARDWARE IDENTIFICATION

1	ALLEN WRENCH (M4 - BLK)		1PC
2	SHORT BOLT (M6 x 40mm - RBW)		2PCS
3	MEDIUM BOLT (M6 x 60mm - RBW)		4PCS
4	LONG BOLT (M6 x 70mm - RBW)		4PCS
5	LOCK WASHER (M6 - RBW)		10PCS
6	FLAT WASHER (M6 - RBW)		10PCS
7	FLAT HEAD SCREW (M4 x 25mm- RBW)		5PCS

NOTE:

Quantities shown are for one chair.

Phillips head screw driver is required in the assembly process; however, manufacturer does not provide this item.

ASSEMBLY INSTRUCTIONS

STEP 1

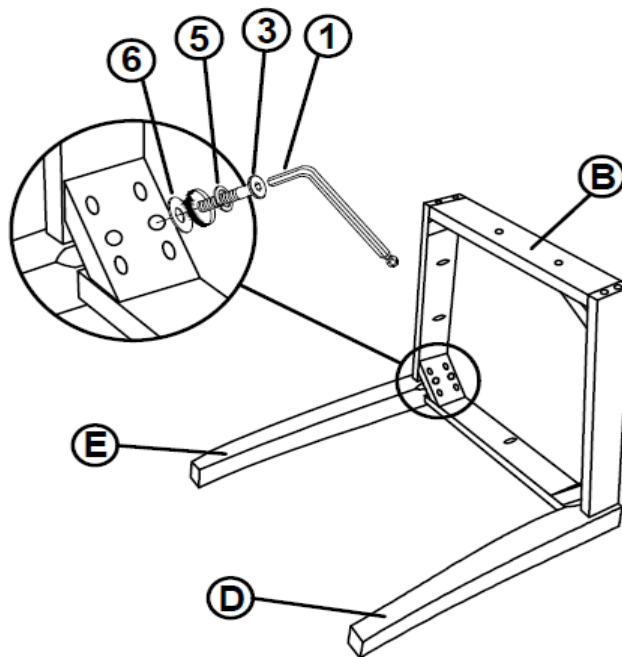

STEP 2

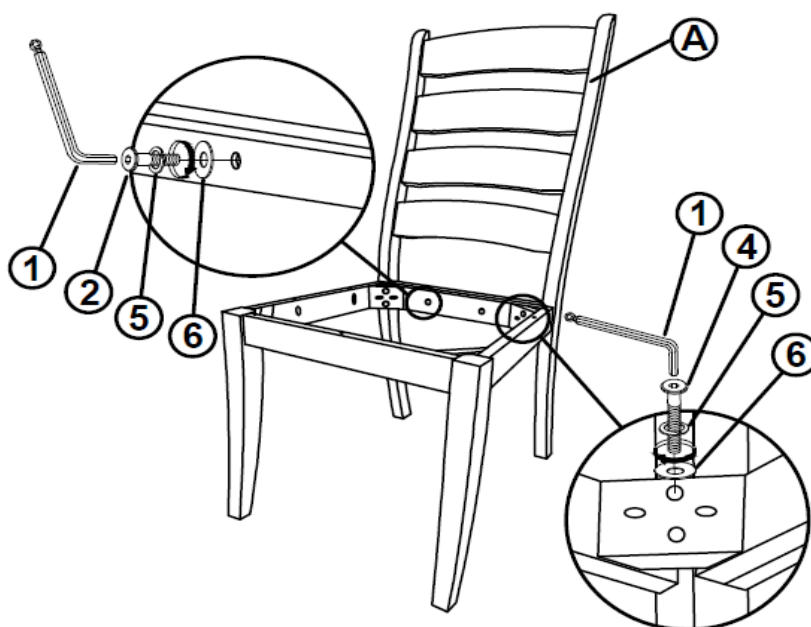

ASSEMBLY INSTRUCTIONS

STEP 3

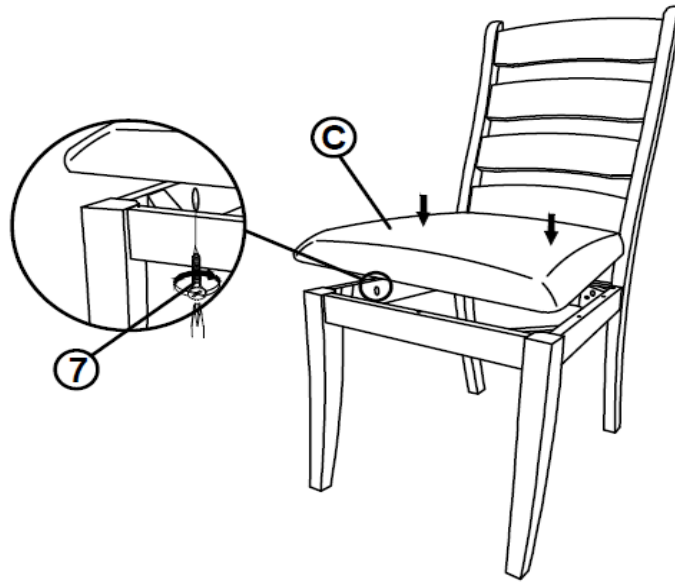

STEP 4

COMPLETE

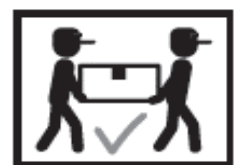
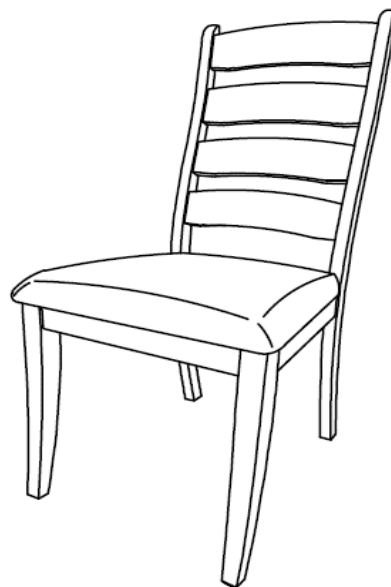

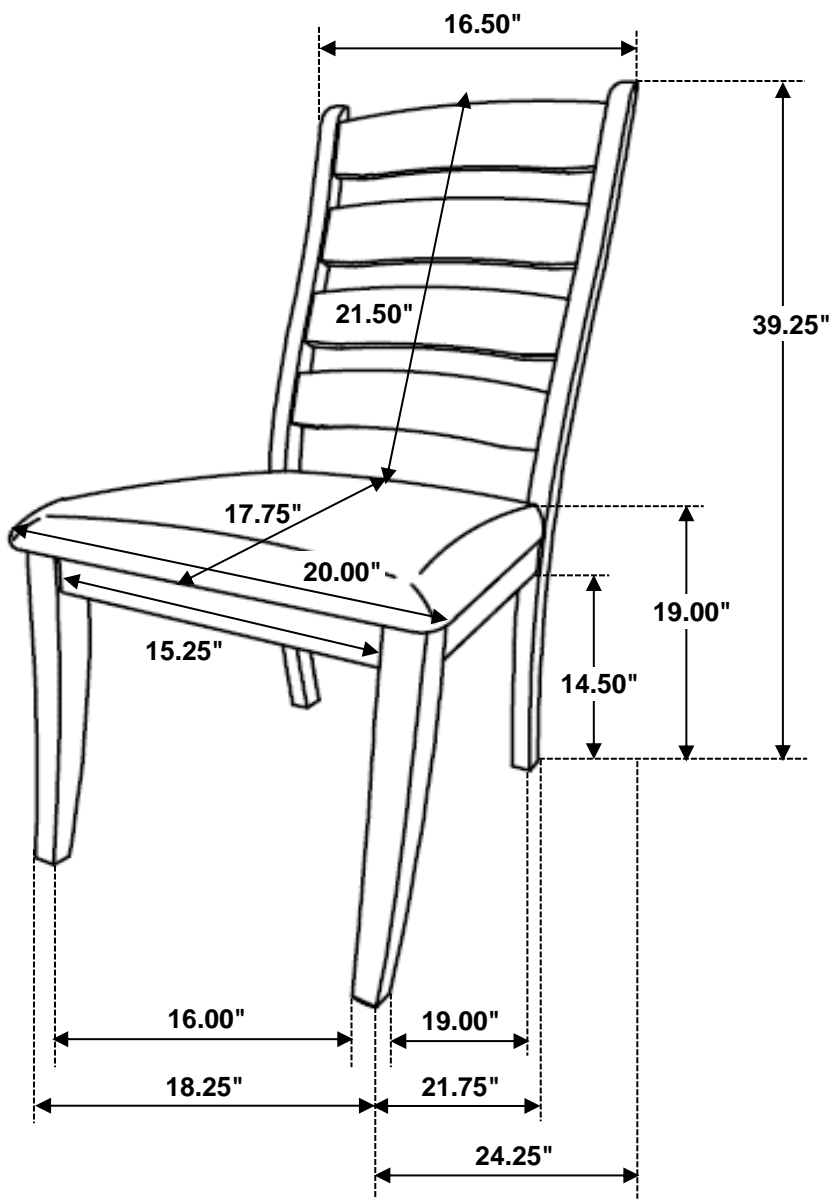

Note: Dimension tolerance $\pm 5\%$