

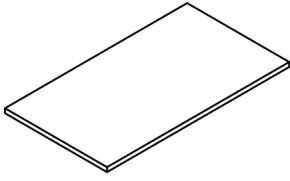

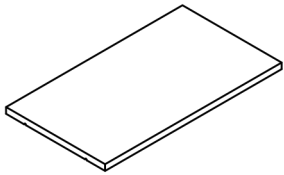

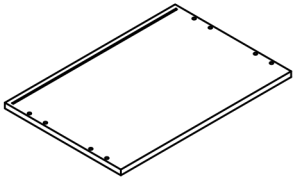

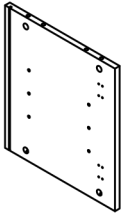
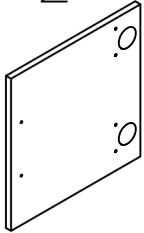
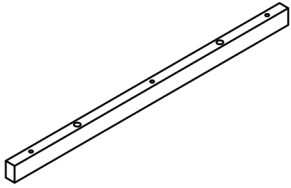
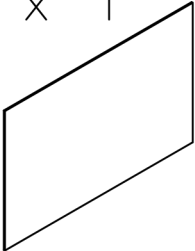

<p>A x 1</p> 	<p>B x 1</p> 	<p>C x 1</p> 	<p>D x 2</p> 
<p>E x 2</p> 	<p>F x 1</p> 	<p>G x 1</p> 	<p>H x 4</p> 
<p>J x 4</p>  <p>80*80*3mm</p>	<p>K x 4</p>  <p>∅26</p>	<p>L x 2</p>  <p>112x30x10</p>	<p>M x 6</p>  <p>15x15x10mm</p>
<p>N x 6</p>  <p>2x15mm</p>	<p>P x 24</p>  <p>3.5x15mm</p>	<p>R x 4</p>  <p>5/32"x20mm</p>	<p>S x 16</p>  <p>1/4"x15mm</p>
<p>T x 8</p>  <p>1/4"x25mm</p>	<p>U x 1</p>  <p>M4</p>	<p>W x 8</p>  <p>∅15x9.5mm</p>	<p>Y x 8</p>  <p>6mmx34mm</p>
<p>Z x 10</p>  <p>∅8x30mm</p>	<p>AA x 4</p>  <p>∅5*∅7*16</p>	<p>AB x 3</p>  <p>4x28mm</p>	<p>AC x 8</p>  <p>∅20</p>

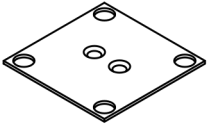
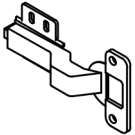
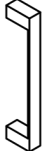
AD x 1

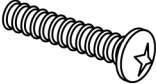
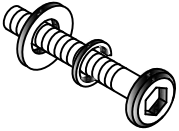
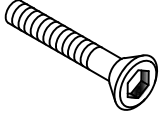

AE x 2

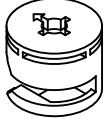
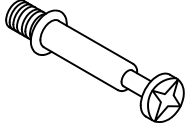
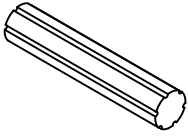
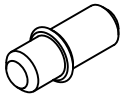
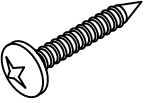
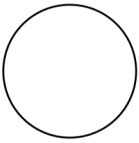

Not Included  
No Se Adjunta  
Non Inclus  
不提供此工具

⚠ NOTE: UNIT SHOULD BE ASSEMBLED BY TWO OR MORE PEOPLE.  
DO NOT TIGHTEN ANY BOLTS UNTIL ALL BOLTS HAVE BEEN STARTED!

⚠ NOTA: ¡ESTA UNIDAD DEBE SER ARMADA POR 2 O MAS PERSONAS!  
NO APRIETE NINGUN PERNO HASTA QUE TODOS ESTEN EN SU LUGAR!

⚠ REMARQUE: LE MEUBLE DOIT ETRE ASSEMBLÉ PAR DEUX PERSONNES OU PLUS.  
NF BLOQUER AUCUN VIS TANT QUF VOUS N'AVFZ PAS COMMFCE A TOUTES LES DEMARRER!

① x2

Px8



3.5x15mm

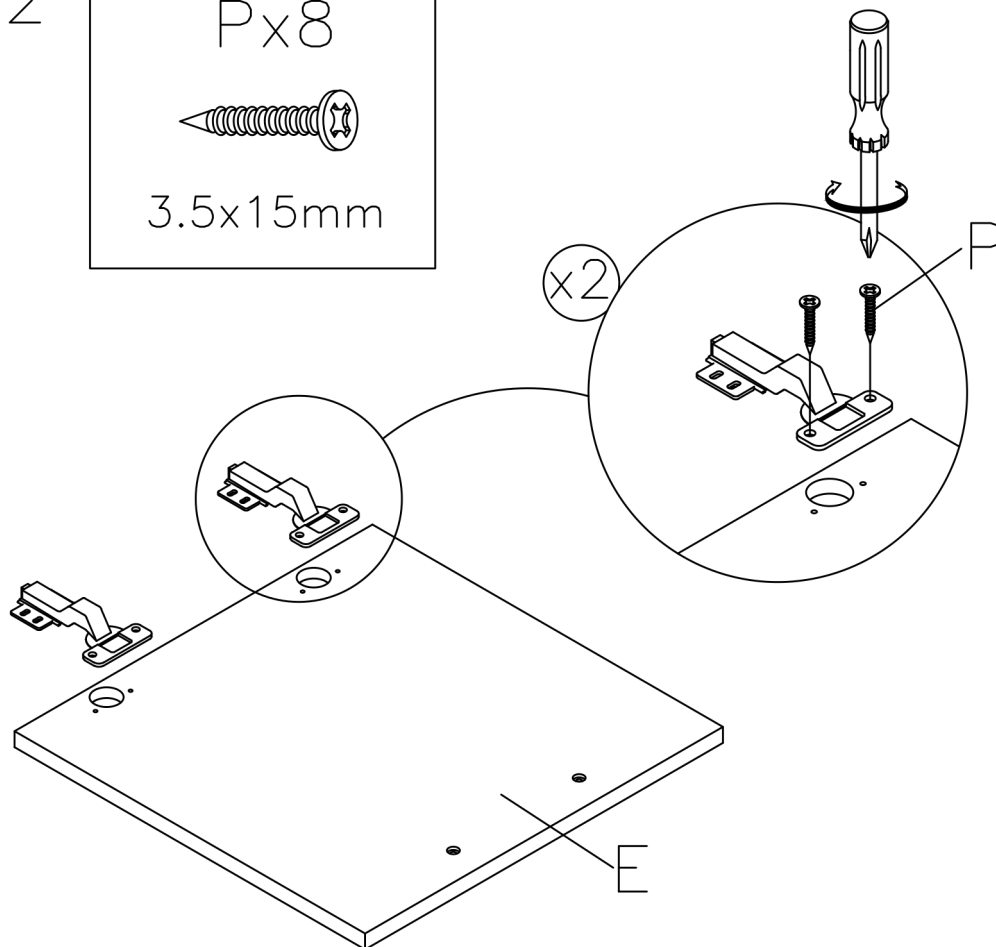

Replacement Parts

② x2

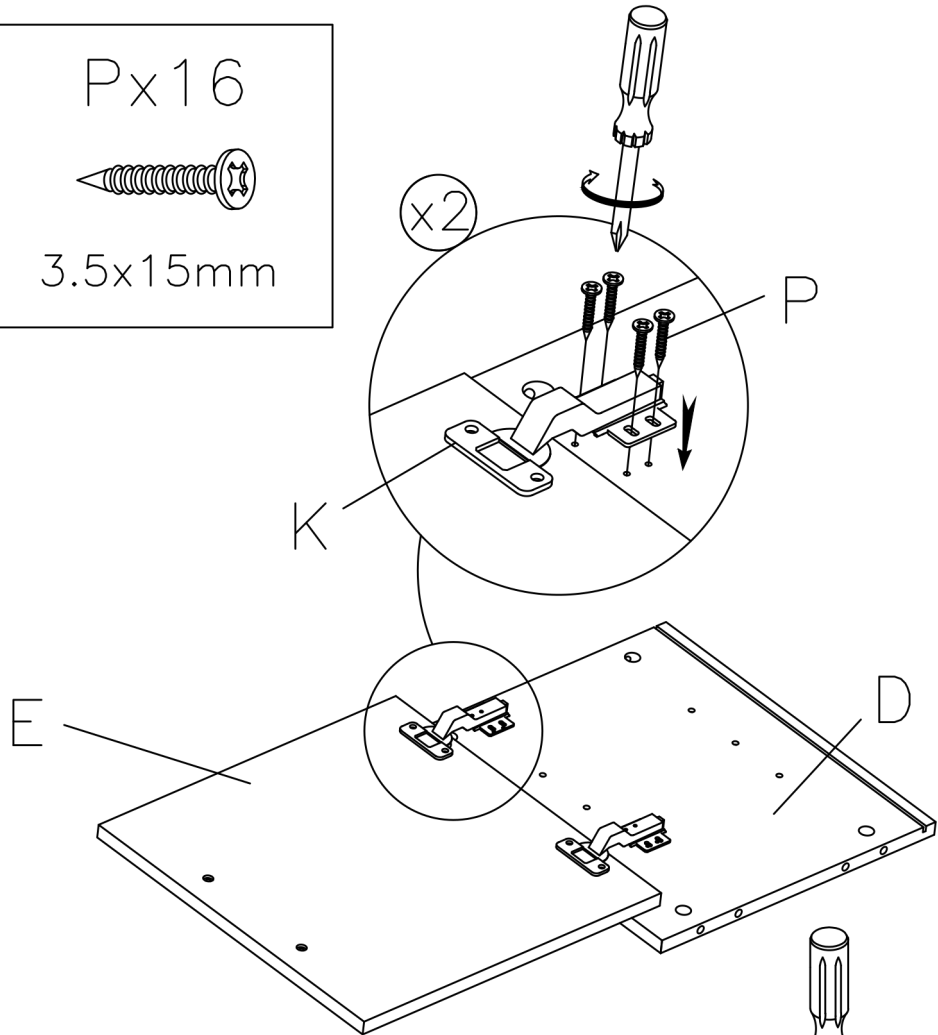
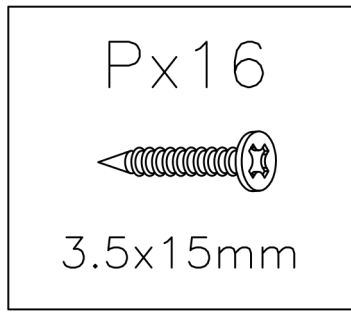

③

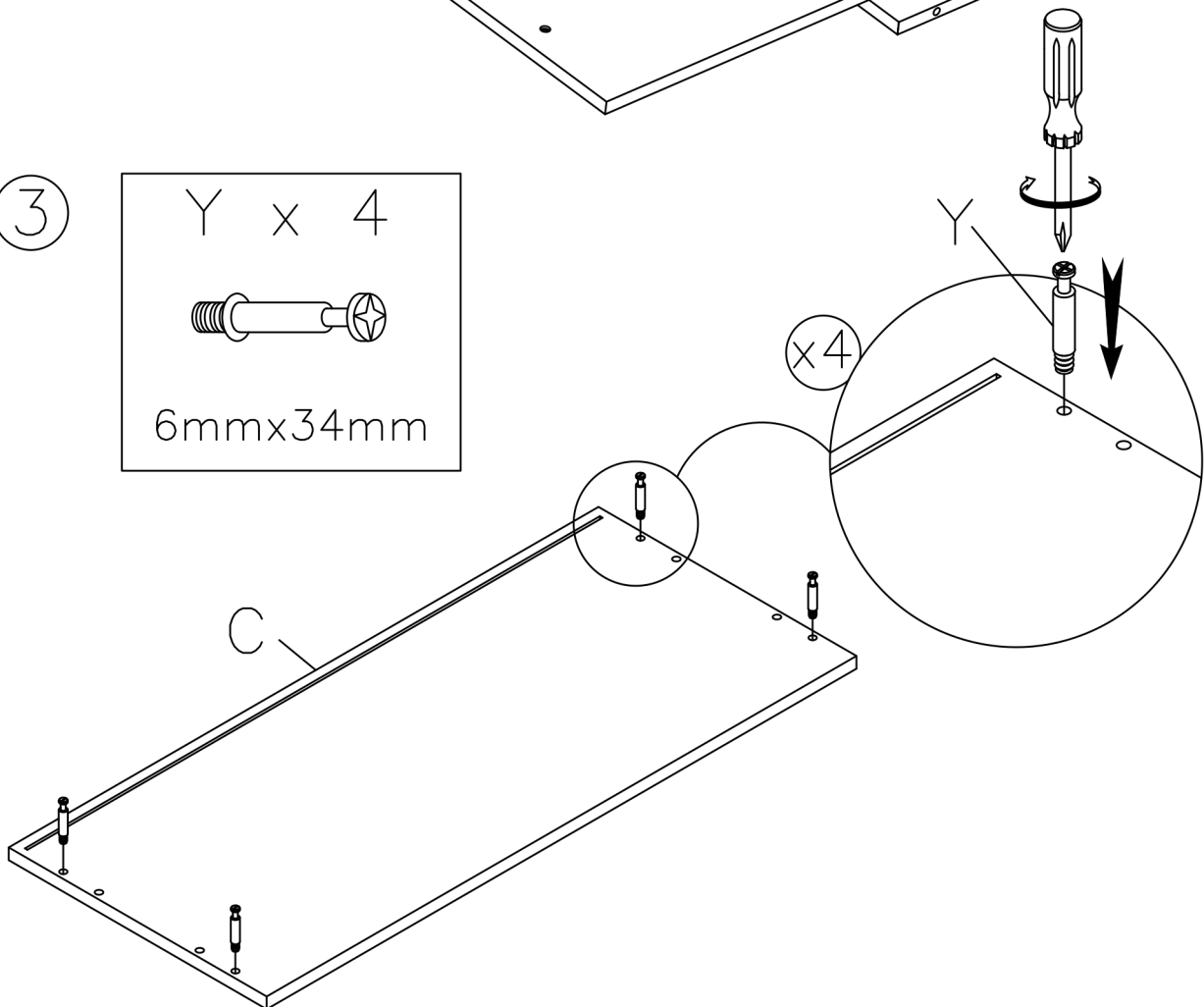
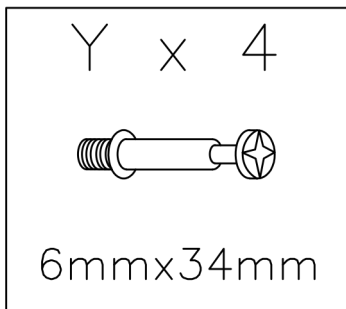

4

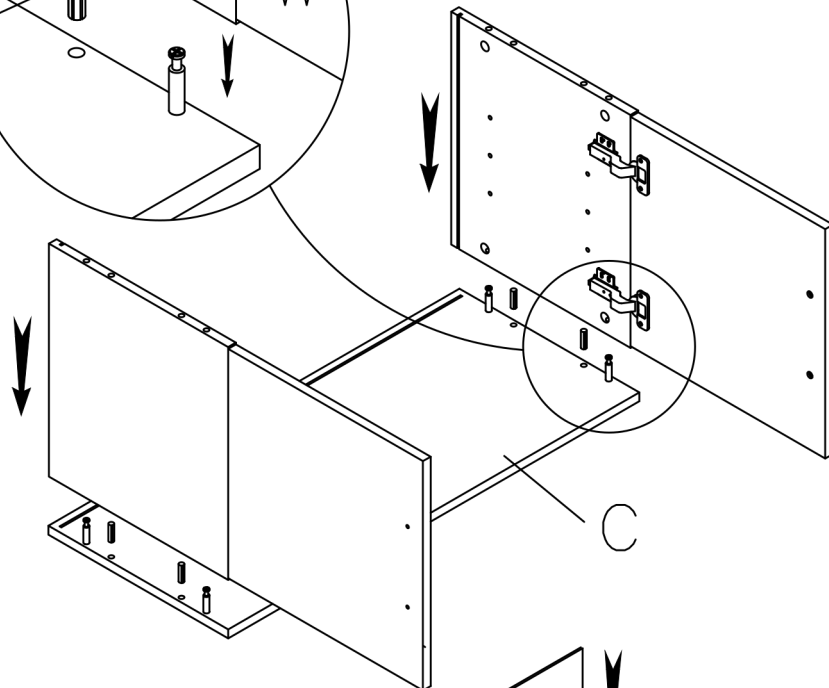
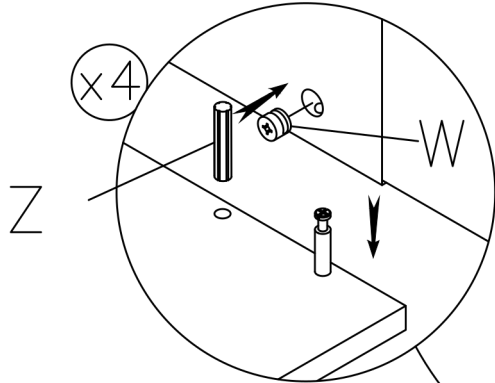
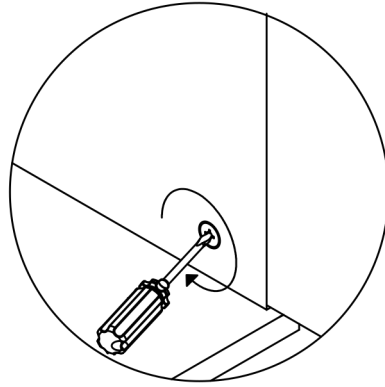
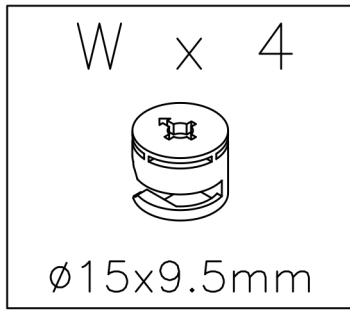

5

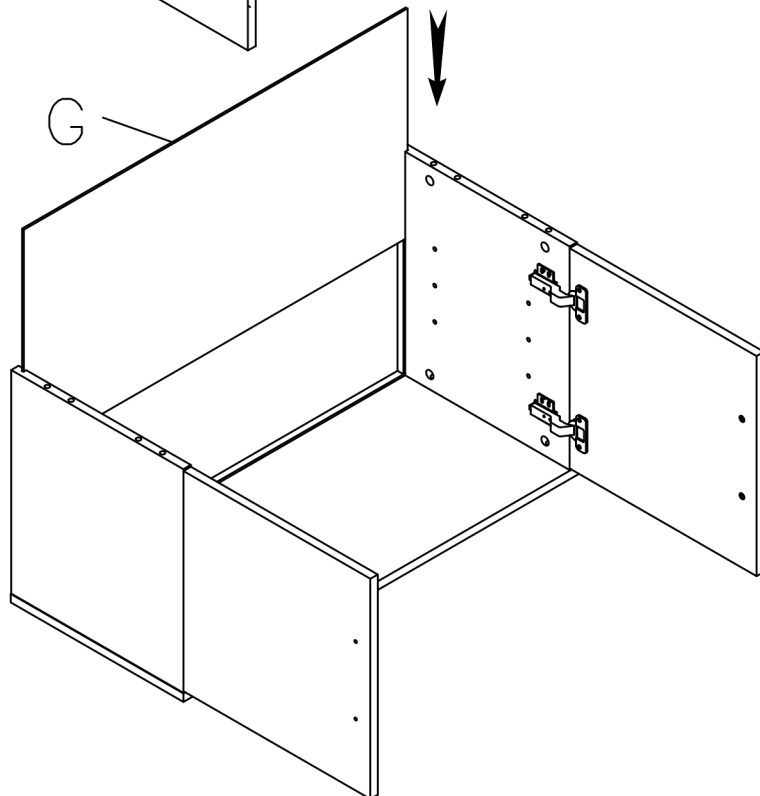

⑥

AB x 3



4x28mm

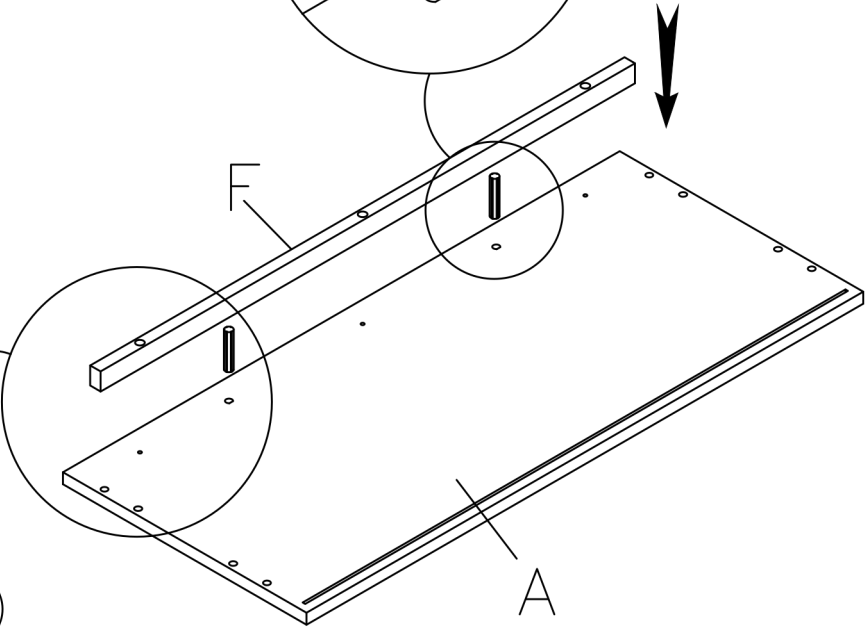
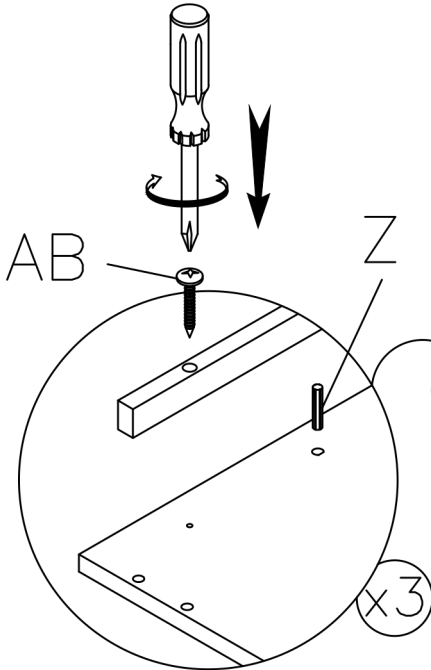
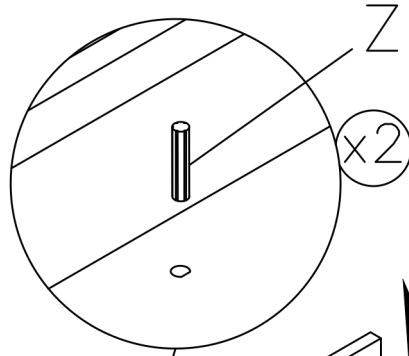

⑦

Y x 4

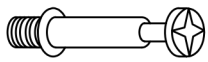

6mmx34mm

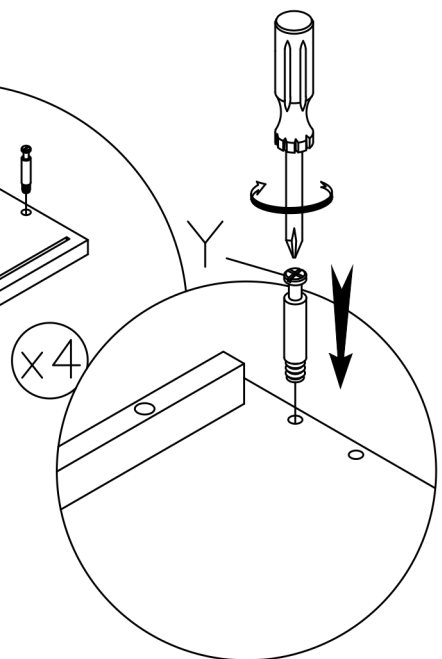
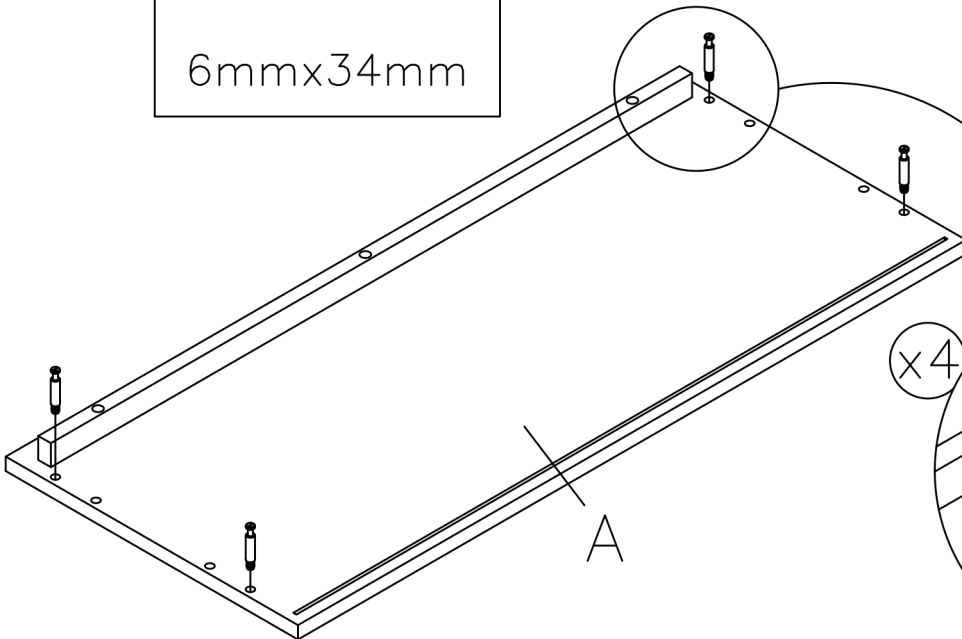
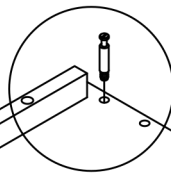

8

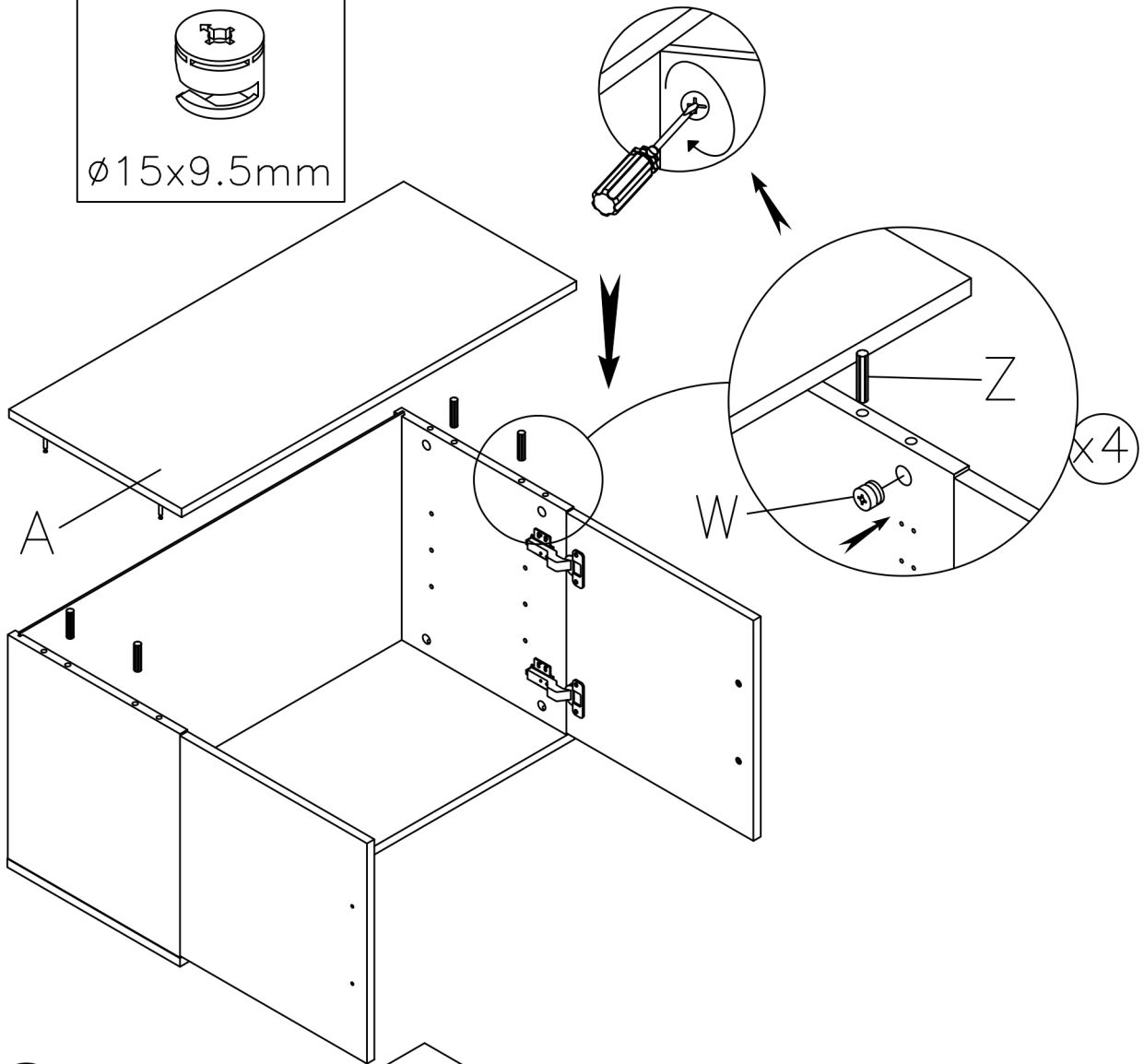
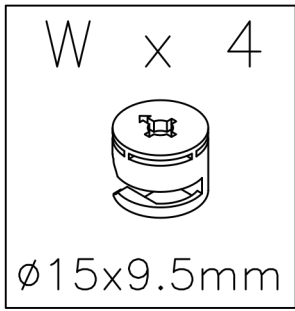

9

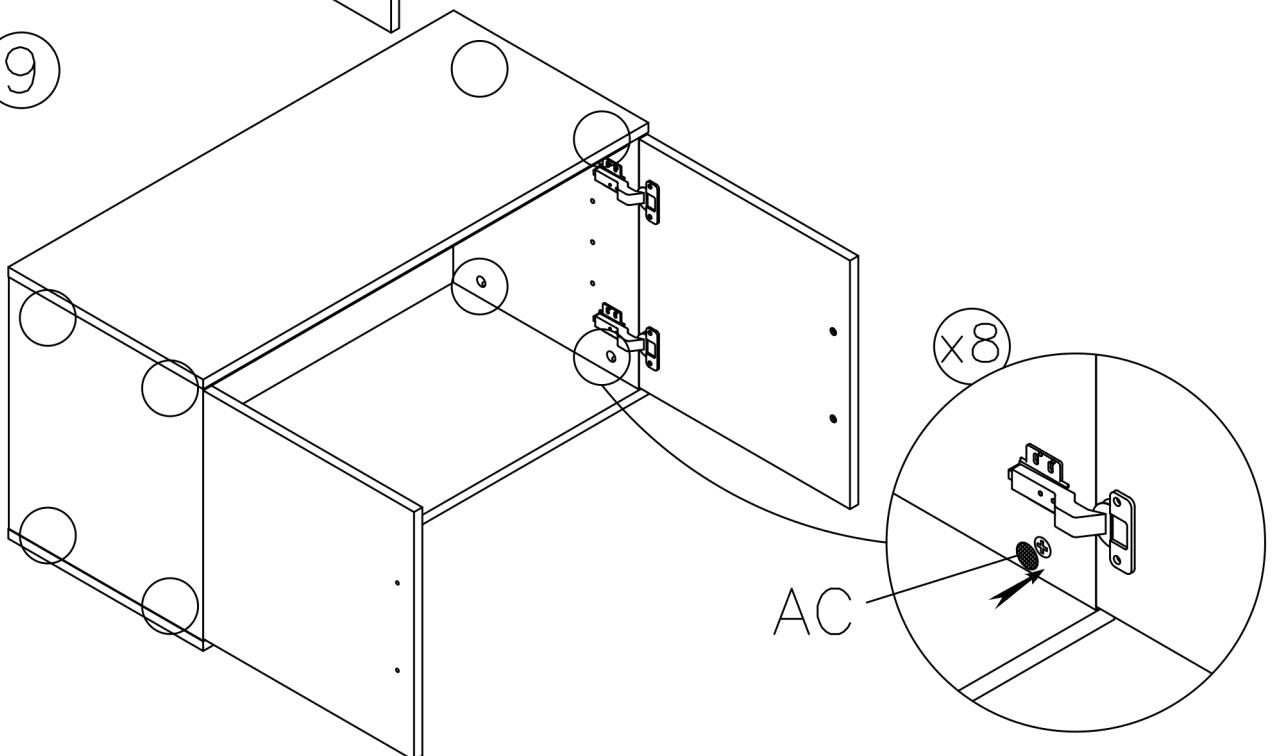

10

R x 4



5/32" x 20mm

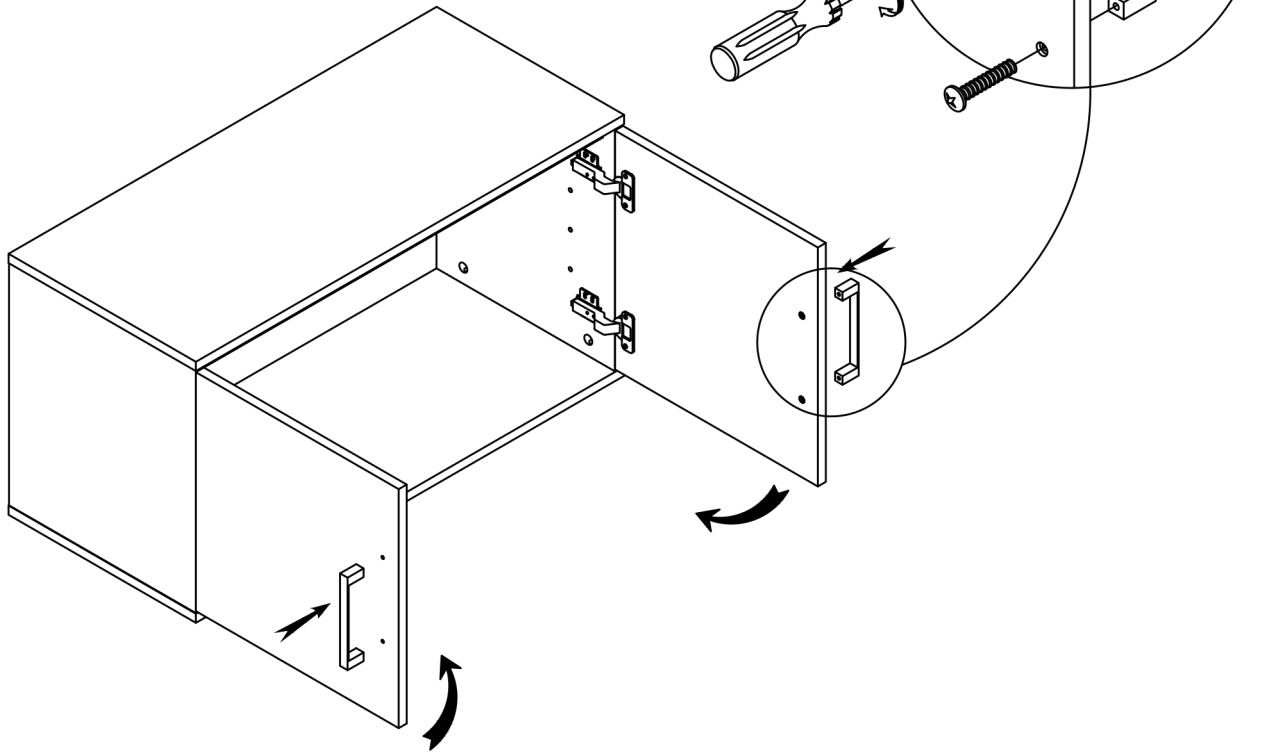

11 x 4

T x 8

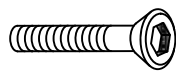

1/4" x 25mm

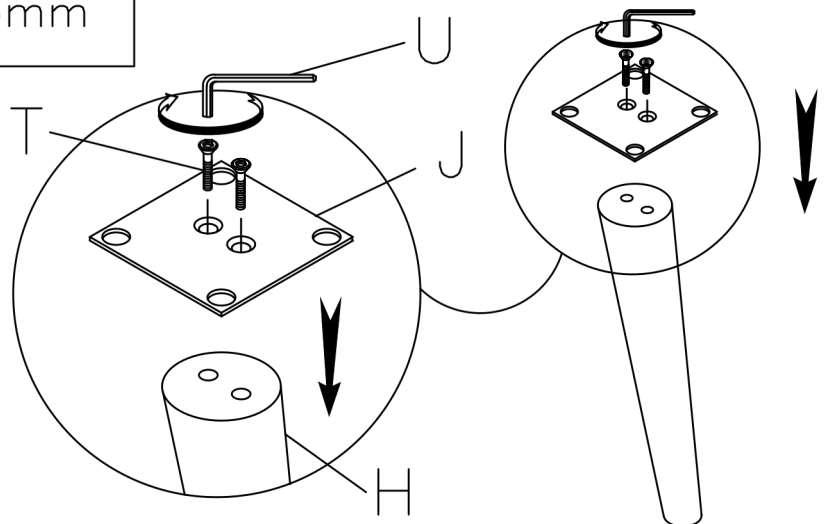

12

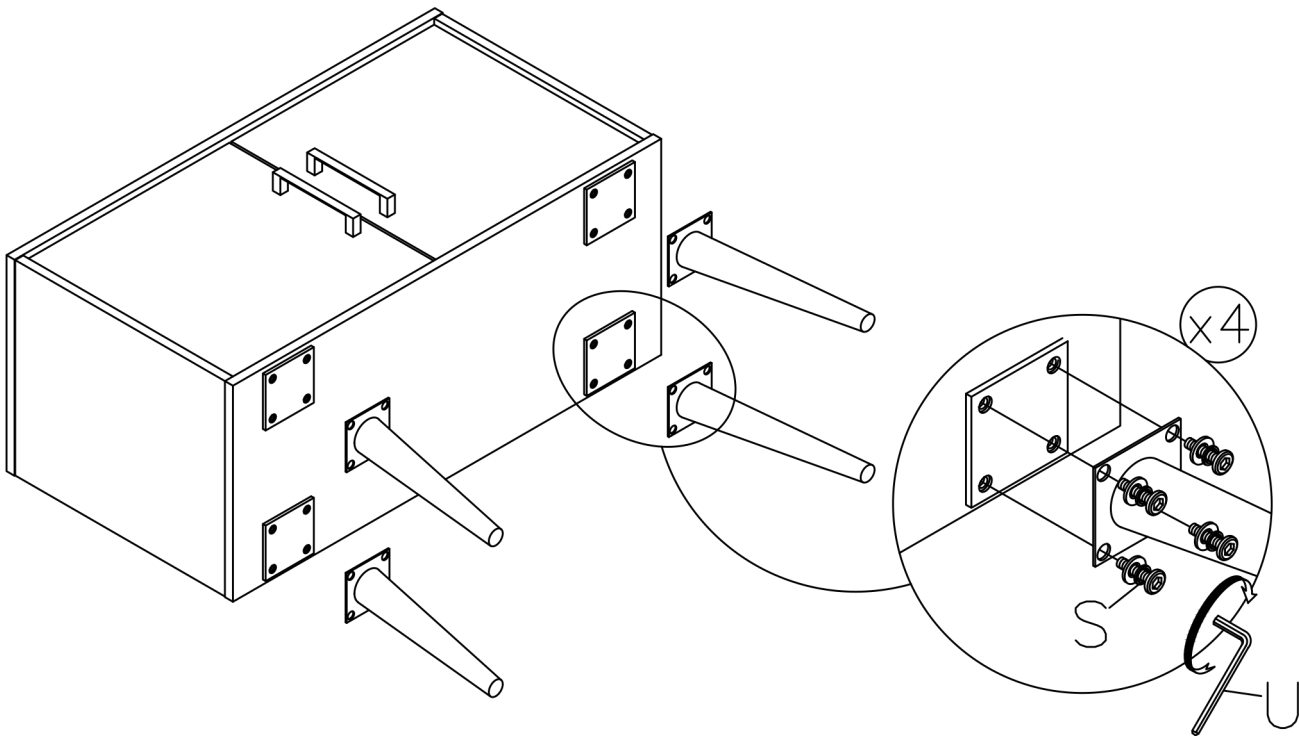
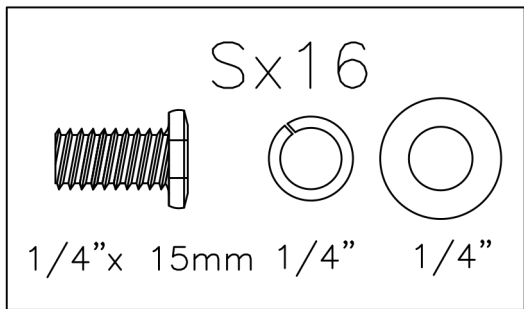

13

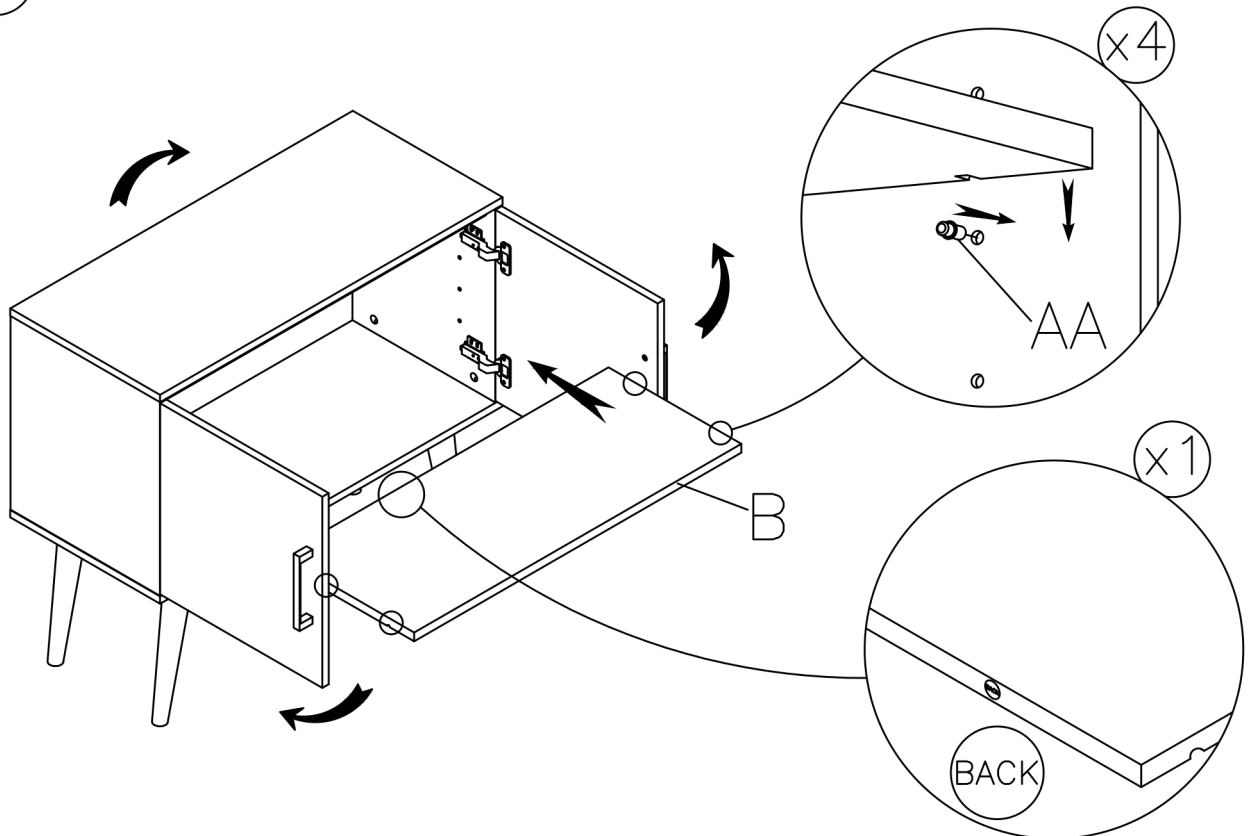

14

N x 6



2x15mm

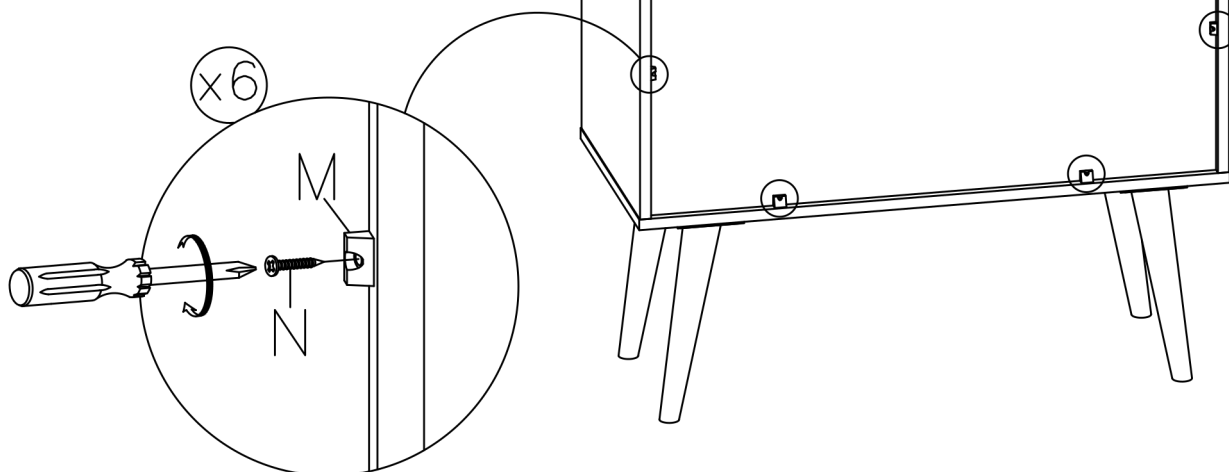

15

**! WARNING !**

The use of the included tipping restraint may reduce, but not eliminate, the risk of furniture tip over. Follow the instructions on the plastic bag for proper installation.

**!ADVERTENCIA!**

El uso del dispositivo diseñado para evitar que el mueble se dé vuelta reduce pero no elimina el riesgo de que eso pueda suceder. Siga las instrucciones que hay en la bolsa plástica para la instalación adecuada.

**! AVERTISSEMENT !**

L'utilisation du système anti-bascule peut réduire, mais n'élimine pas, les risques de renversement du meuble. Suivez les instructions se trouvant sur le sac en plastique pour l'installer correctement.

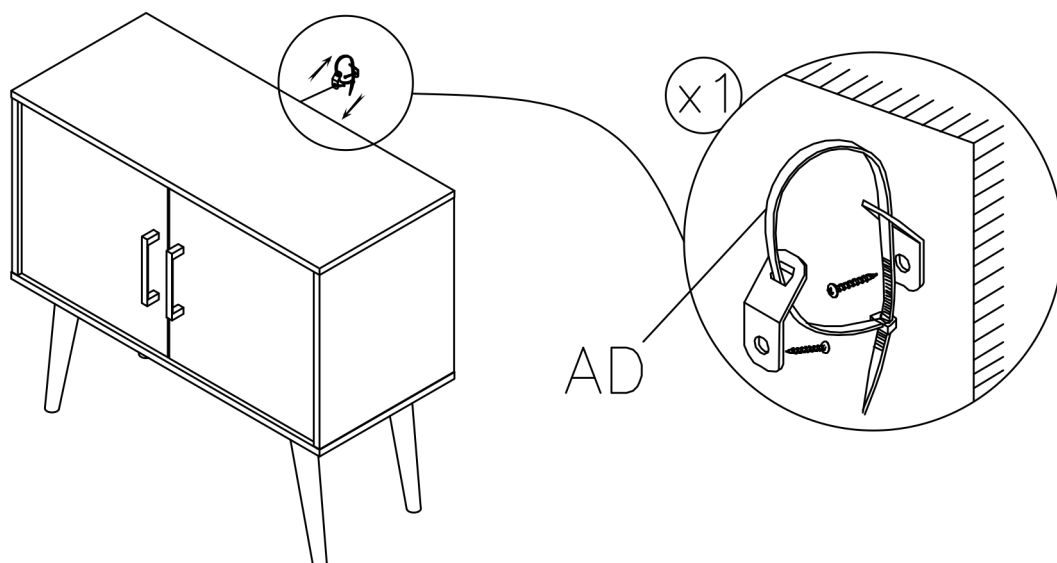

16

NOTE: IF THE UNIT IS PLACED ON AN UNLEVEL SURFACE, PLACE A LEVELER UNDERNEATH ONE FOOT UNTIL THE UNIT IS LEVEL. BREAK OFF ANY PROTRUDING SEGMENTS.

NOTA: EN CASO DE QUE EL DISPOSITIVO ESTÉ COLOCADO SOBRE UNA SUPERFICIE DESNIVELADA, PONGA UN NIVELADOR POR DEBAJO DE UNA PATA DE DISPOSITIVO HASTA QUE EL CUAL ESTÉ NIVELADO. ROMPA CUALQUIERA DE LOS SEGMENTOS QUE SOBRESALEN.

REMARQUE: SI L'UNITE EST PLACEE SUR UNE SURFACE DE NON-NIVEAU, PLACEZ UN NIVELEUR SUR UNE PIE JUSQUE A CETTE UNITE EST PLACEE, ROMPREZ TOUT SEGMENTS SAILLANTS.

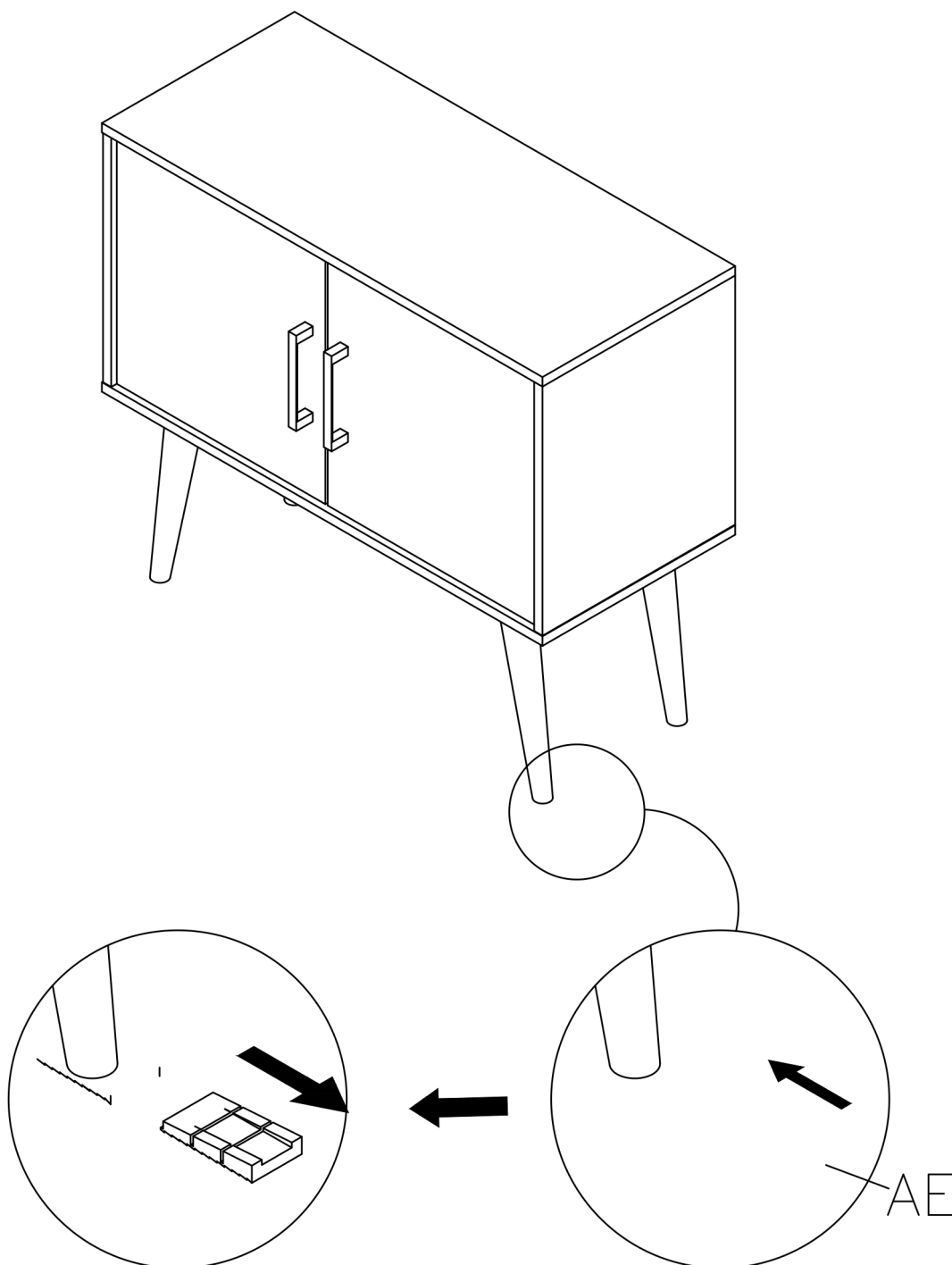

OPTIONAL: To adjust your doors to make the gaps more even.  
 OPCIONAL: Para ajustar las puertas para hacer los boquetes más incluso.  
 FACULTATIF: Pour ajuster vos portes pour rendre les espaces plus encore.

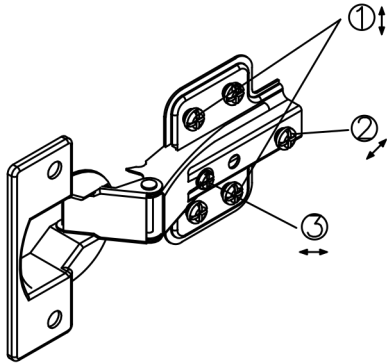

ENGLISH

- ① Door height adjusts screws (up & down).
- ② Adjusts distance between door and cabinet (in & out).
- ③ Adjusts distance between door and cabinet (side to side).

ESPAÑOL

- ① La altura de la puerta ajusta los tornillos (para arriba y abajo).
- ② Ajusta distancia entre la puerta y el gabinete (en y hacia fuera).
- ③ Ajusta distancia entre la puerta y el gabinete (lado al lado).

FRANCAIS

- ① L'ajustement des vis (vers le haut et vers le bas).
- ② L'ajustement des la distance entre la porte et le coffret (dedans et dehors).
- ③ L'ajustement de la distance entre la porte et le coffret (cote a cote).

