



# INSTRUCTION MANUAL

---

THREESEATS SOFA

## NOTICE

Please retain these instructions for future reference.

Please do not exceed the weight limitations of this item.

Do not stand on or use any part of this item as a step ladder.

Firmly secure all bolts, screws and knobs before use.

Reconfirm that all bolts, screws, and knobs are secure every 90 days.

Fasten screws loosely during initial assembly. Do not firmly tighten the screws until the item is completely assembled.

Be aware that some parts are heavy and have sharp edges.

If any parts are missing, broken, damaged, or worn, stop using this product until repairs are made and/or factory replacement parts are installed.

Do not use this item in a way inconsistent with the manufacturer's instructions as this could void the product warranty.

## TOOLS REQUIRED

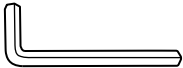

ALLEN WRENCH  
(PROVIDED)



300 LBS  
PER SEAT

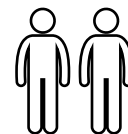

2 PERSON  
ASSEMBLY



APPROXIMATELY  
90 MIN.  
ASSEMBLY

## HARDWARE

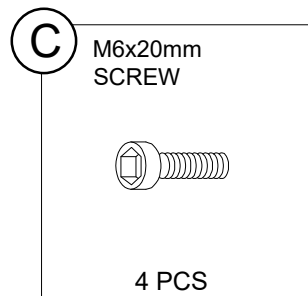
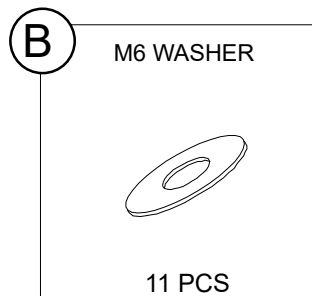
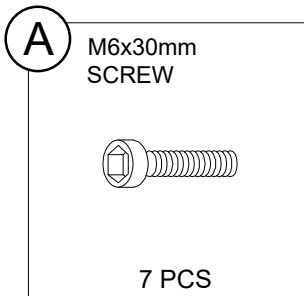

Use tools to attach hardware in the following way:

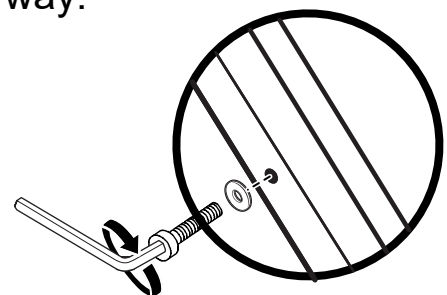

PARTS

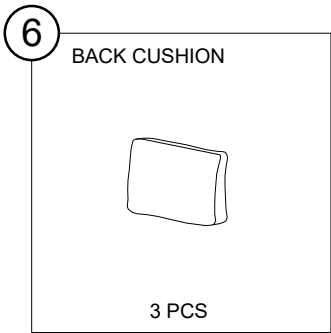
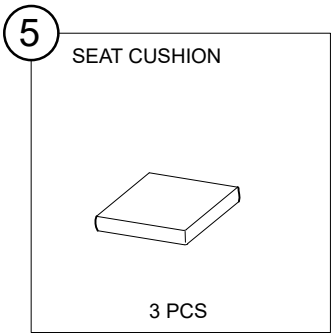
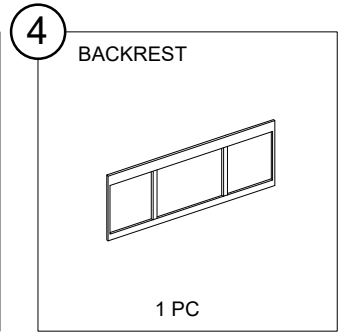
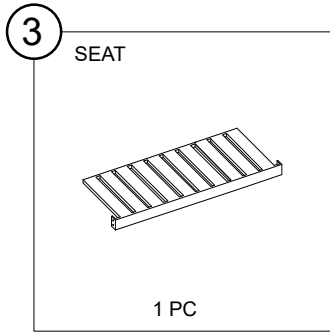
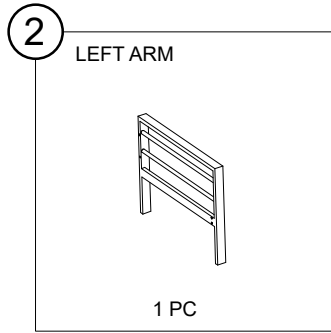
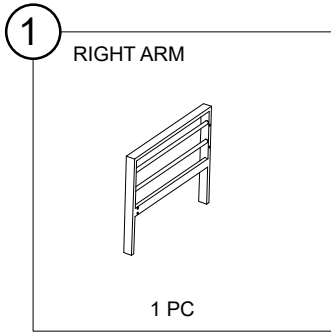

# PRODUCT ASSEMBLY - THREESEATS SOFA

1

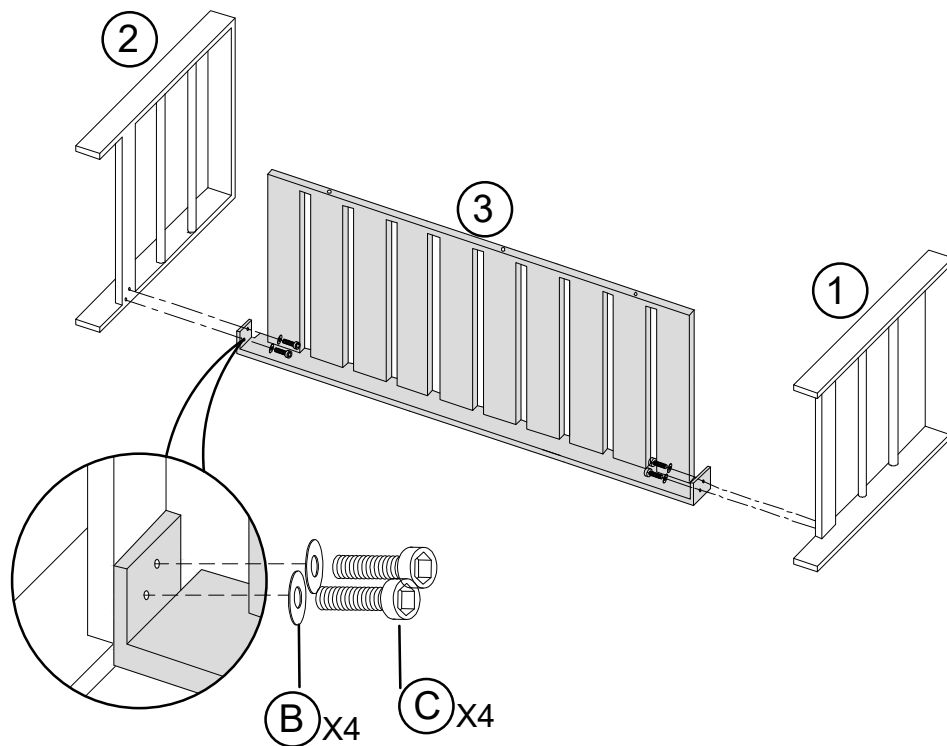

2

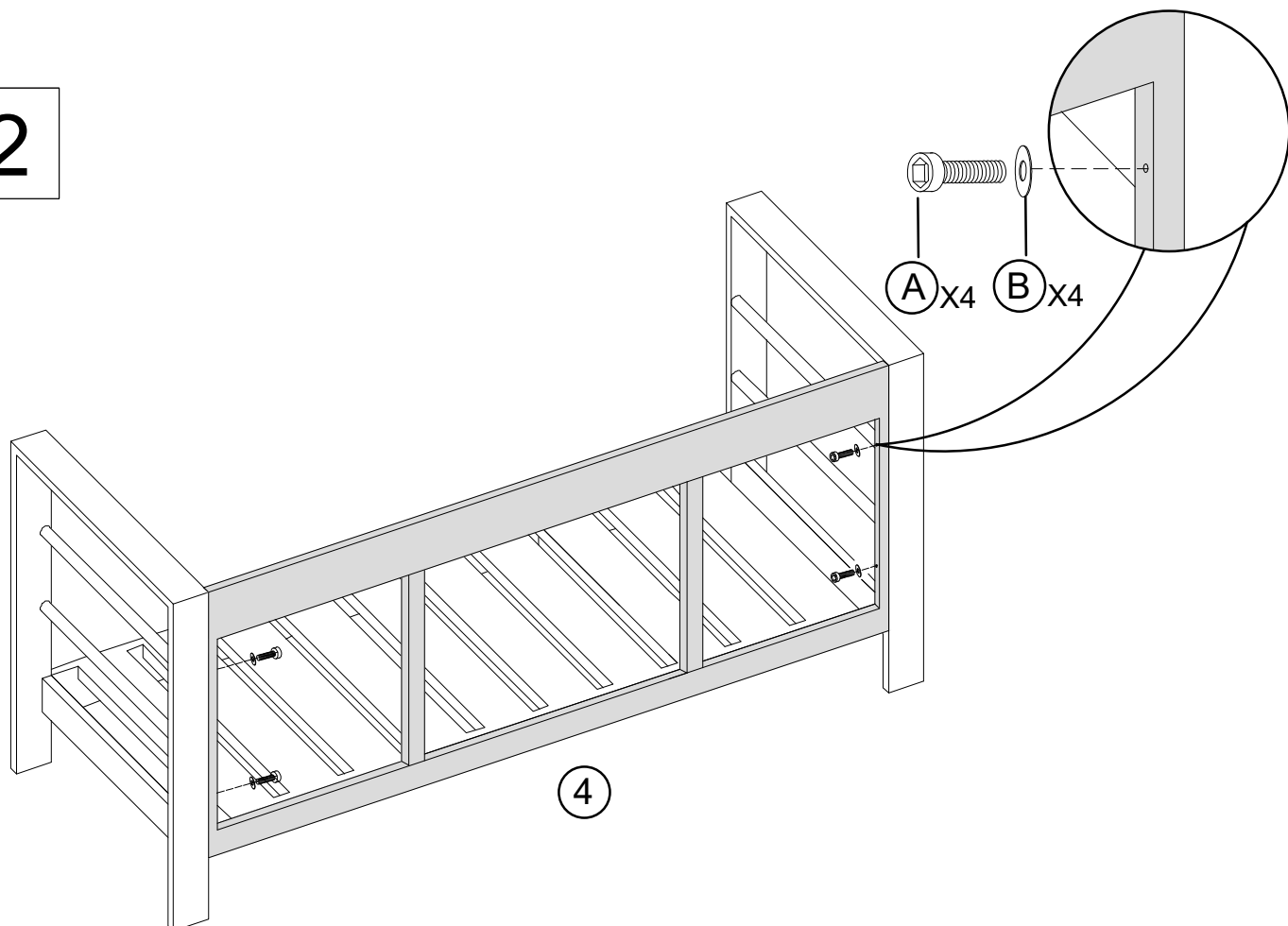

# PRODUCT ASSEMBLY - THREESEATS SOFA

3

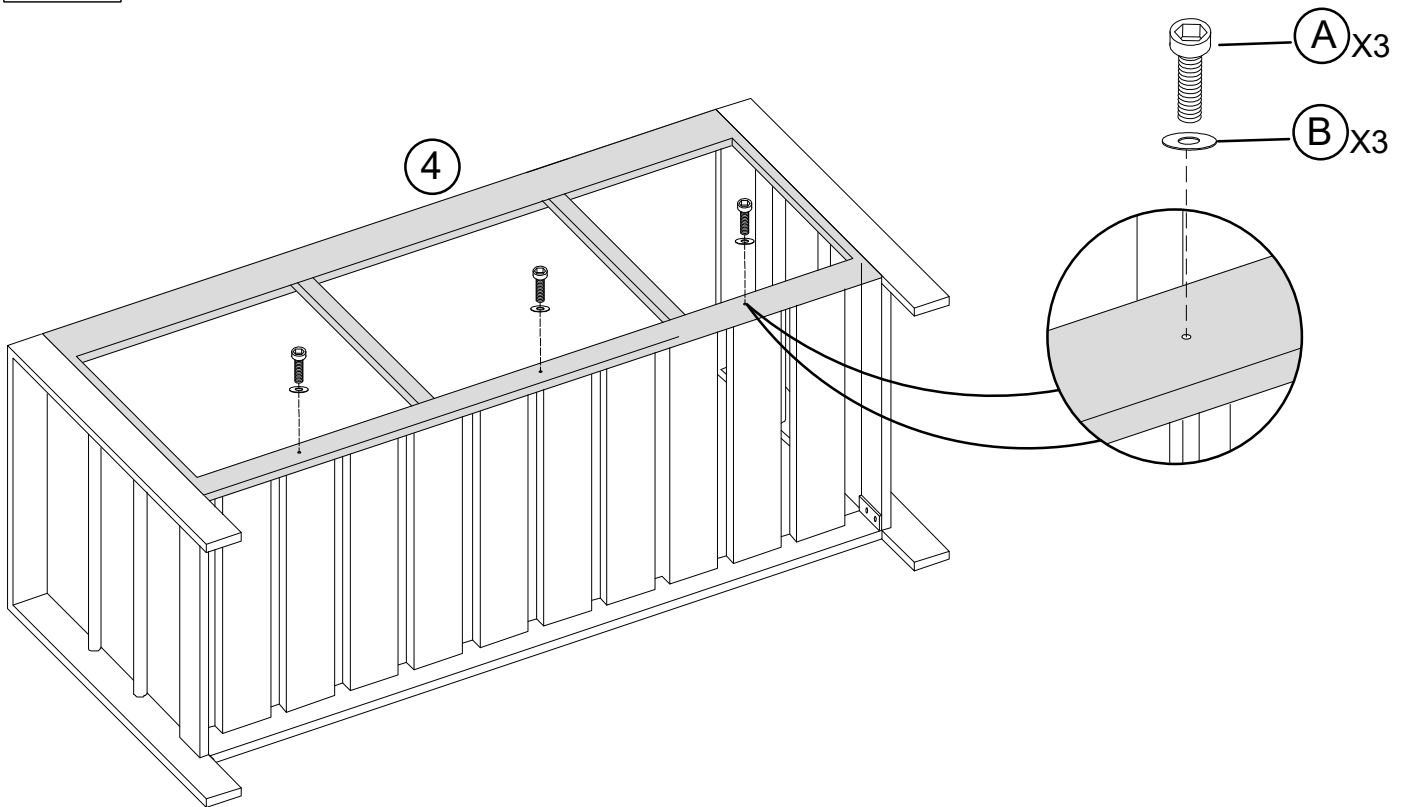

# PRODUCT ASSEMBLY - CUSHIONS

NOTE: Cushions are not waterproof; they are water resistant and can only withstand light rain. Do not leave cushions out in inclement weather

1

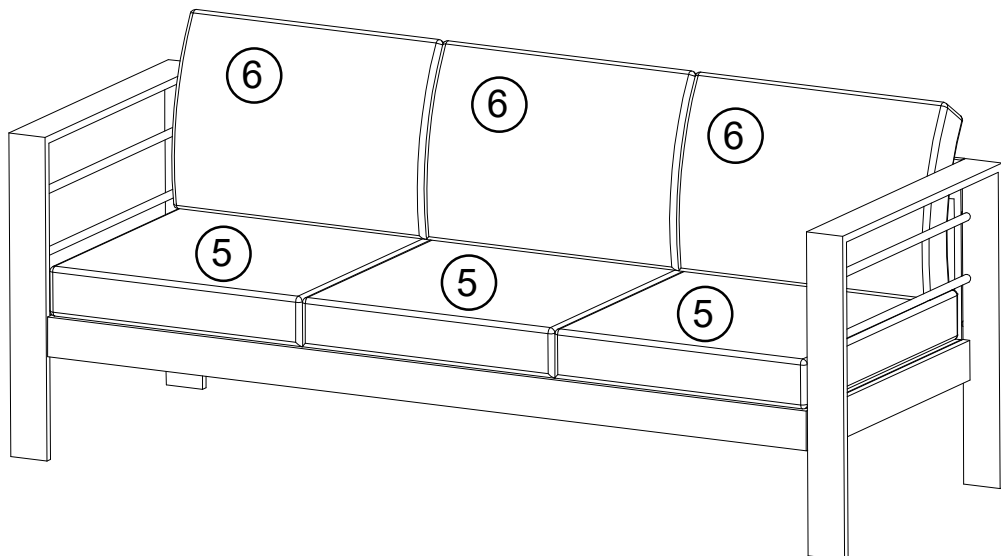

# HELP CENTER

Question about your product? We're here to help. Contact us:



Chat Support



Product Inquiry



Orders FAQ



Product Assembly



Returns & Refunds

## PRODUCT WARRANTY INFORMATION

All items can be returned for any reason within 30 days of the receipt and will receive the refund as long as the item is returned in its original product packaging and all accessories from its original shipment are included

All returns must be shipped back to the Return Center at the customer's expense. If the reason for return is a result of an error then we will provide a pre-paid shipping label via email. Once an item has been received refunds or replacements will be processed within 5

business days. Boxes for return shipping will not be provided, and it is the customer's responsibility to either use the original shipping boxes or purchase new boxes.

Pictures may be required for some returns to ensure an item is not damaged prior to its return. Items returned are not considered undamaged until they are received and verified as such. All damages to items are the customer's responsibility until the item has been received and acknowledged as undamaged.

## WARNING

Manufacturer and seller expressly disclaim any and all liability for personal injury, property damage or loss, whether direct, indirect, or incidental, resulting from the incorrect attachment, improper use, inadequate maintenance, or neglect of this product.