

HAPPINESS HAPPINESS INSTALLATION

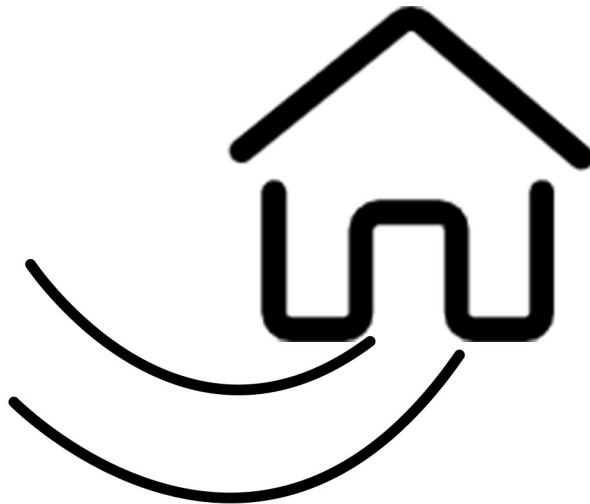

CAUTION

Parts are placed at the bottom of the product.

- If you have any questions with the product, please contact us by:
- **Email: customerservice@zoy-living.com**
(we will reply to you within 24 hours)

Assembly Instructions

RR5504AF

This product comes in three kinds of packages. Carefully remove all of components from the packaging and set aside for assembly.





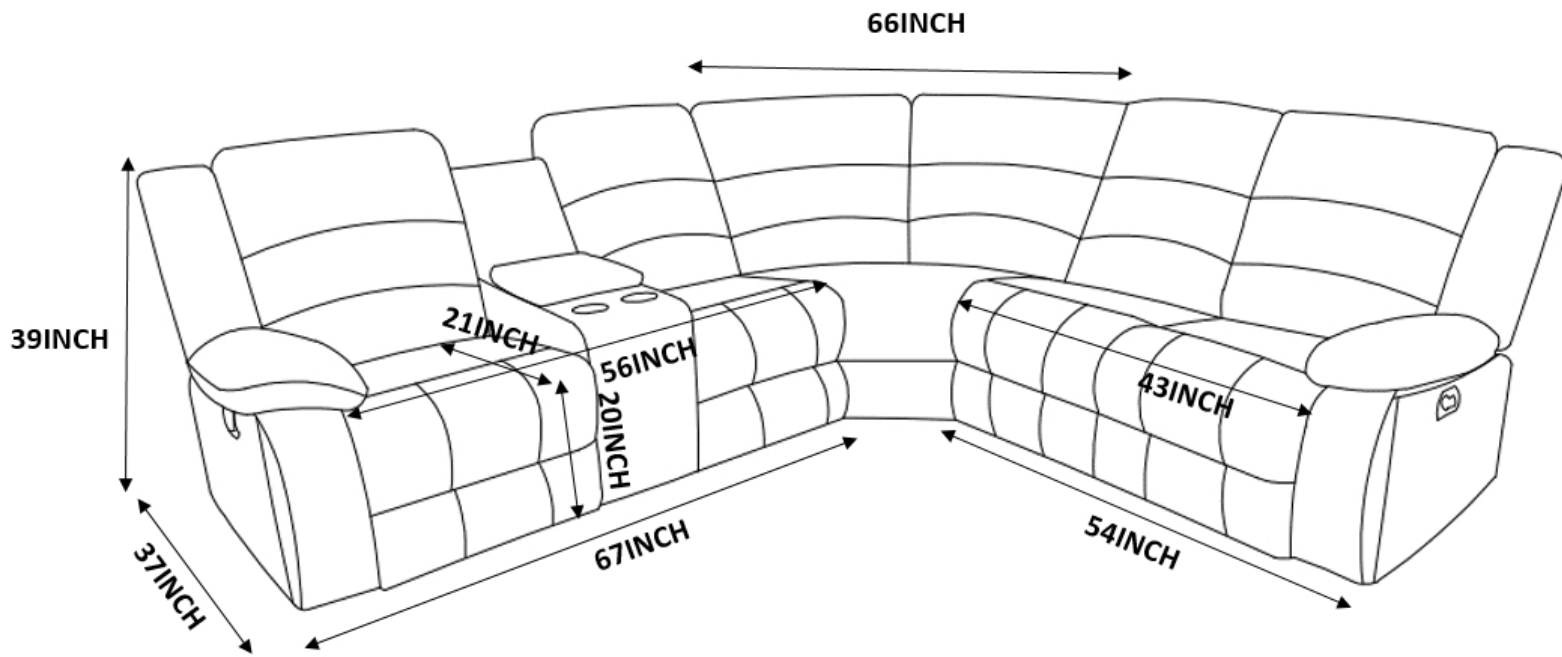



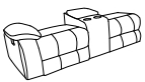

CAUTION

DO NOT use any sharp objects to open plastic-wrapped components as this may result in damage to the product or components.

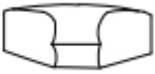
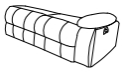

RR5504AF52LC+RW5504AF61N+RR5504AF52RZ

Package Contents

				BOX RR5504AF52LC
A*1	B*1	C*1	F*1	
				BOX RW5504AF61N
I*1	J*1			
				BOX RR5504AF52RZ
D*2	G*1			
				
H*1	E*1	C*1	K*1	

STEP1:

Remove parts from the bottom of the seat.

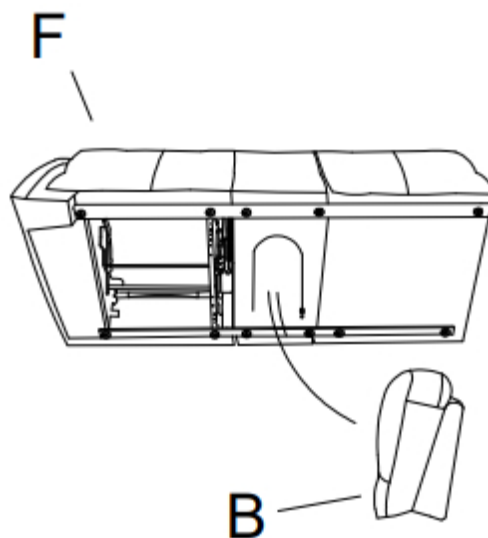

STEP2:

Attach **Back (A&B&C&D&E)** to **Seat (F&G&H)** by aligning the metal grooves on backrest to brackets on the mainframe as shown and align **Ears (J&K)** to **Backrest (A&E)**. Then attach **Seat(F&H)** to **Center Seat (G)** by aligning the metal grooves on seat to seat on the mainframe as shown. Ensure the **Seat(F&H)** slide down fully over the brackets on the **Center Seat (G)** .

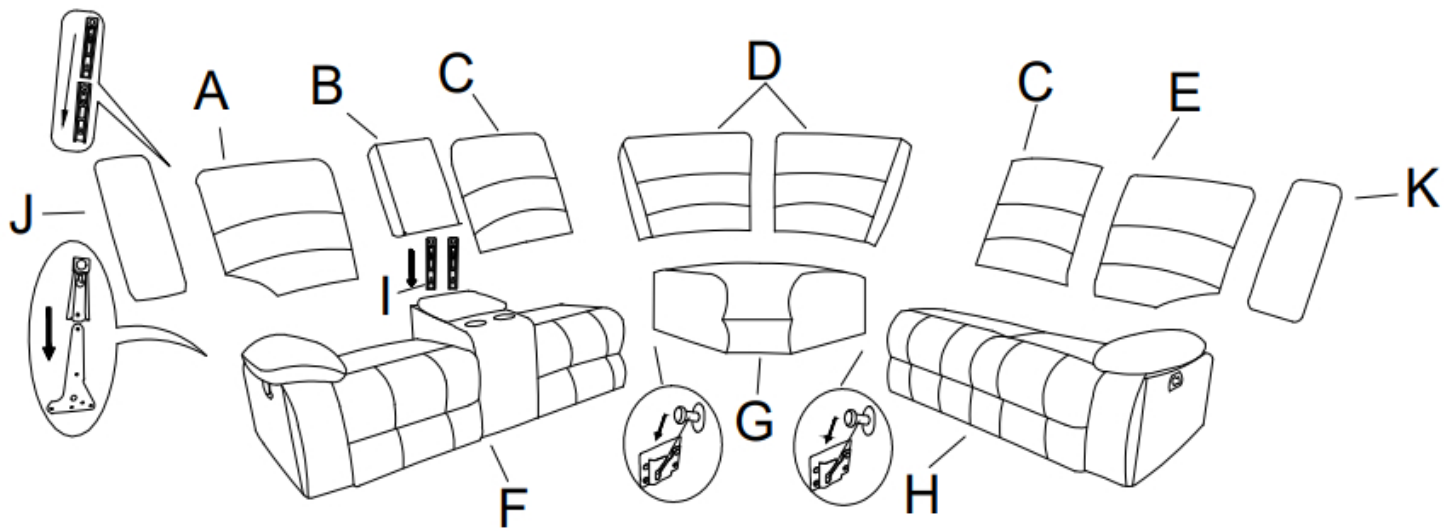

ASSEMBLY COMPLETED

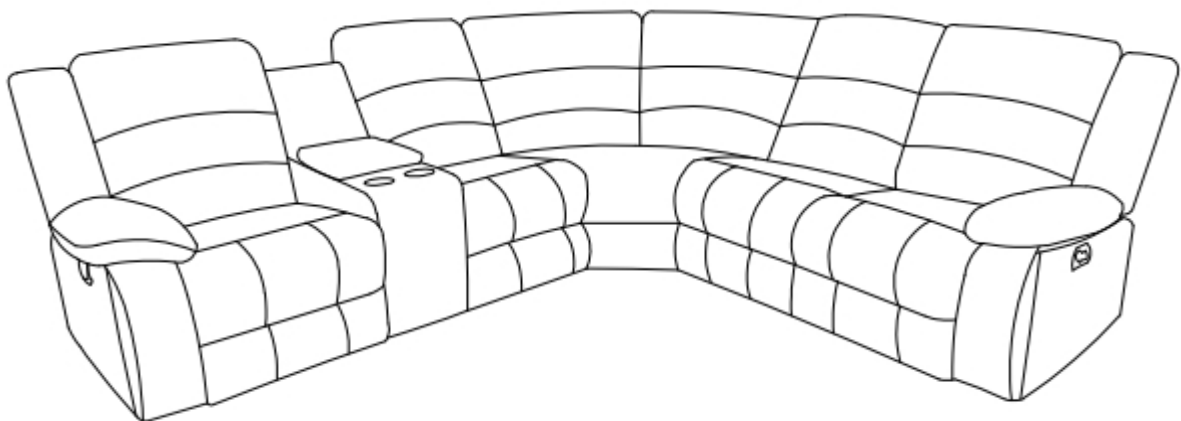

Warnings

1. Please check if the components of the chair are all included and can be used normally.
2. Assemble all components according to the instruction correctly before you connect the chair to the power.
3. Please DO NOT sit on the armrests or footrest to eliminate the risk of tipping over.
4. If the chair is damaged or doesn't match the website description, please send clear pictures of the product and label of the carton to our service team for further help.
5. If the recliner doesn't work, you may try the following measures for self-checking firstly:
 - a) Check if all the cables are connected;
 - b) Check if the light of transformer is on.

If the chair still doesn't work, please feed the information back to our customer service in time and we'll help you solve the matter as soon as possible.

6. If you have any questions with the product, please contact us by:

Email: customerservice@zoy-living.com (we will reply to you within 24 hours)

