



Installation Instruction

Model : 9318

Edition:2023030701Z

Preface

Thank you for choosing this chair.

You've made a wise choice for yourself, a comfortable and durable chair is an important part of a happy life.

Before enjoying it, you have to assemble it together. This guide will take you through the basic assembly process. To ensure smooth installation, please follow the assembly instructions, especially the important safety information.

Besides, although you can assemble the chair yourself, but there is a second person to help you make it more accommodating easy.

Before you start, check if there get some missing parts in the package. If you have any questions, please do not hesitate to email us, we will help you as soon as possible. If you encounter any difficulties during the assembly process, please remember to check the assembly process, see if you missed something. If you can not solve your problem, feel free to email us and our team will help you.

After-Sale Email Address: Kasorixchair-service@outlook.com

Parts List

(A)

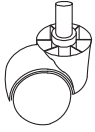

5*Wheels

(B)

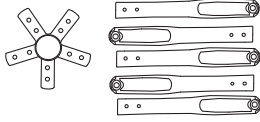

1*Star Base+5*Feet of Chair

(C)

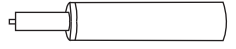

1*Gas Lift

(D)

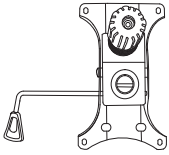

1*Seat Plate

(E)

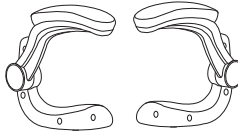

2*Armrests

(F)

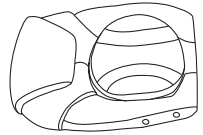

1*Backrest

(G)



1*Cushion

(H)

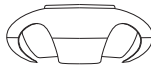

1*Connector

(1)

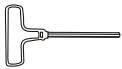

Wrench x1

(2)



M6*10 x10

(3)



M6*20 x4

(4)



M6*25 x8

(5)



x8

Installation Steps

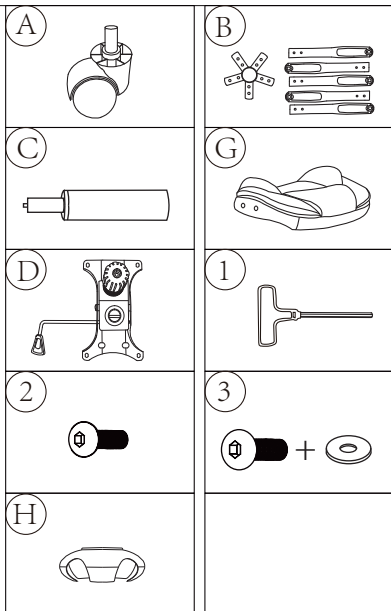
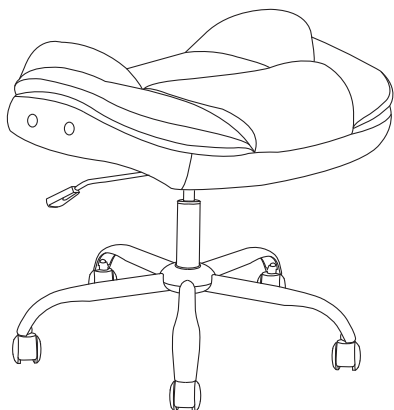

1

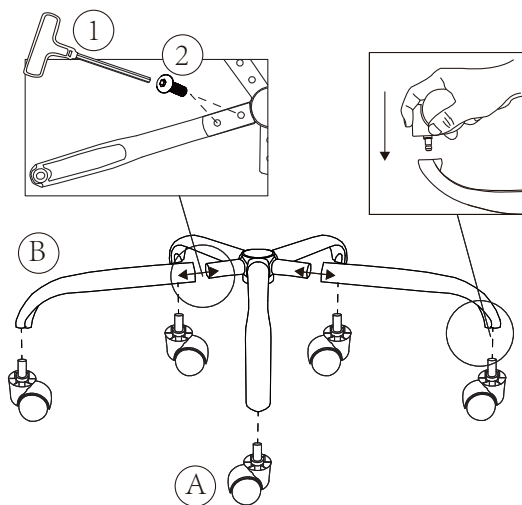

2

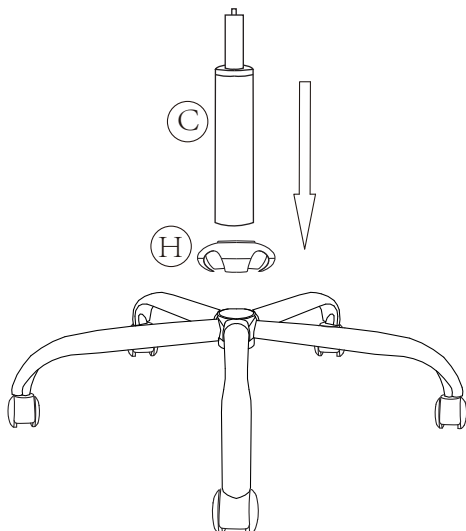

Installation Steps

1. Connect the feet of chair to the star base with wrench and screws ②, and then insert wheels(A) into each hole at the end of (B).
2. Install (H) and (C) vertically in the middle hole of (B).
3. Put the bottom of (G) upward, and install (D) on the bottom of (G) with ③ screws. (Note: Please identify the front and back directions of (G) carefully.)
4. Install (G) vertically on (C). (The top of (C) is inserted into the middle hole of (D).)

3

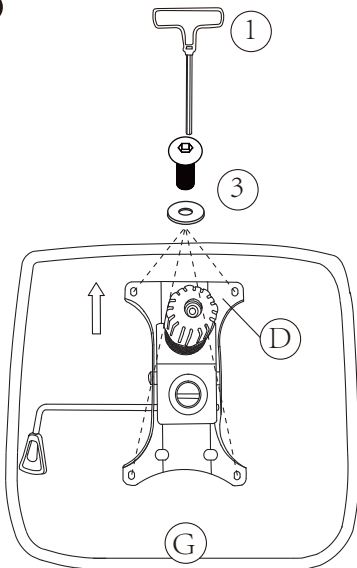



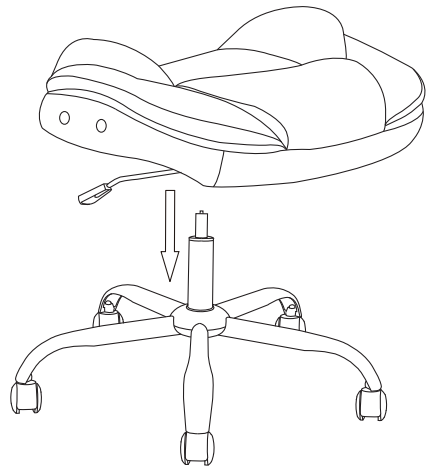

4



Installation Steps

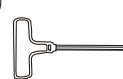

F 	E 
1 	4 
5 	

5

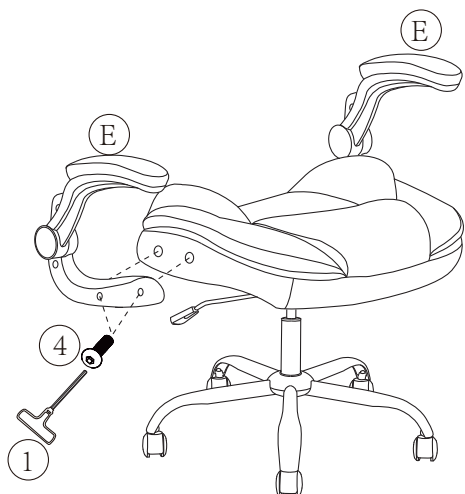

6

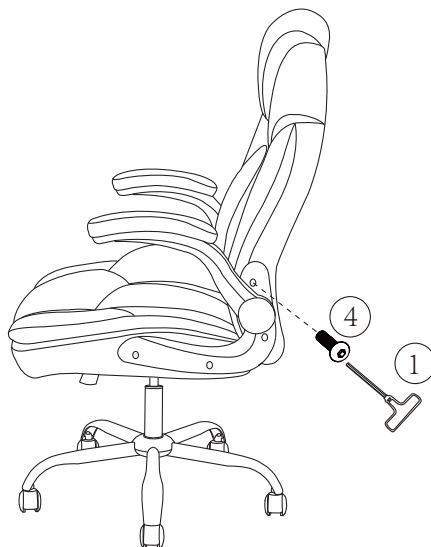

Installation Steps

5. Install the lower hole of (E) on both sides of (G) using ④ screws.
6. Place (F) on (G) and install the top hole of (E) on the corresponding positions on both sides of (F) using ④ screws.
7. Install the second hole on the upper end of (E) to the corresponding positions on both sides of (F) using ④ screws.
8. Cover the holes of armrests with ⑤ one by one and the chair is fully assembled now.

7

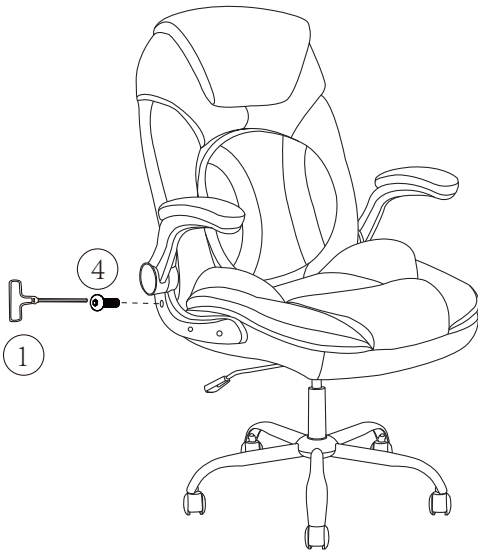

8

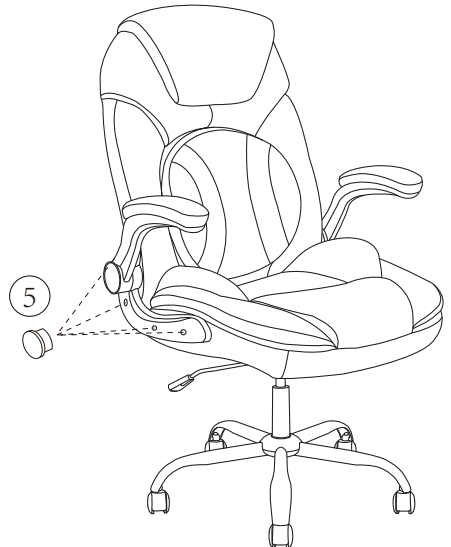

Instructions For Use

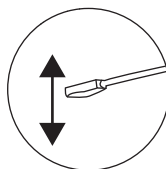

Raise:
Transfer the weight from the chair and lift up the right handle.

Lowering:
Transfer the weight to the chair and lift up the right handle.

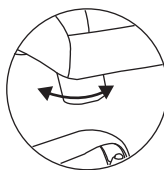
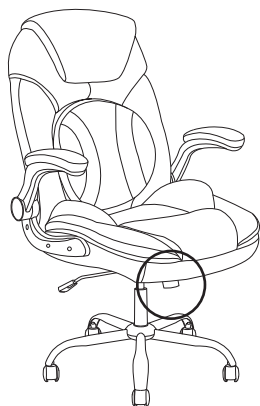

Turn the tray knob at the bottom of the chair cushion to adjust the reclining tension of the seat.

Safety And Maintenance

- Do not stand on a chair, and do not use a chair as a stepladder.
- Use this product for seating one person at a time.
- Do not use the chair unless all bolts and screws are firmly secured.
- Avoid contact with sharp objects to prevent puncturing the fabric.
- Every 6 months, check all bolts and screws to ensure they are tight.
- To clean the seat cushion, it is recommended to use a vacuum cleaner or wipe with a dry cloth.
- Chair weight limit not to exceed 300 LBS.

SAFETY INFORMATION



Sit in the center of the chair, with your back to the backrest



Do not sit at the front edge of the chair



Do not stand on the chair



Do not use the chair with more than one person



Do not push the chair around when a person is sitting in it



Do not push down on the backrest when a person is reclined



Do not place all your weight on the backrest only



Do not place all your hand or fingers near the recline mechanism

Product Warranty

Promises to repair or replace any chair that is found to be defective in material or workmanship within one (1) and year from the date of original purchase so long as you, the original purchaser, still owns it. This is your sole and exclusive remedy. This warranty is subject to the provisions below.

EXCLUSIONS:

This warranty does not apply and no other warranty applies to:

- Normal wear and tear, which are to be expected over the course of ownership.
- Misuse, abuse or excessive use of the product.
- Modifications or attachments to the product that are not approved .
- Products that were not installed, used, or maintained in accordance with product instructions and warnings.
- Products used for rental or commercial purposes.
- Damage caused by the carrier in-transit is handled under separate terms.

Seating Usage: Normal use for seating is identified as the equivalent of a single shift, forty- (40) hour workweek. To the extent that a seating product is used in a manner exceeding this, the applicable warranty period will be reduced in a pro-rata manner.

Some retailers might have custom models imported direct from the factory and therefore are not supported by our local service team because we don't have the correct parts, please contact your retailer directly for support. If you have any questions about that we will be happy to assist and identify those items.

RETURN POLICY:

We adopt a 30 days return policy which means that all products purchased on this website may be returned to us within the timeframe. You need to contact us within 30 days after the product(s) came into your possession and the product(s) must be returned to us without any undue delays.

Limited Warranty

Returned products must be returned in the same condition as they were sent and they must be sent in its original packaging.

If the product is not faulty, (i.e. if you changed your mind or if you are unhappy with the product for some other reason), the cost of shipping will fall on you. And it is your responsibility that the package arrives safely to us so we recommend that you use a courier service where it is possible to track the shipment.

If the product is faulty when you receive it please contact us and we will help you out (see more information under Manufacturer Warranty).

We reserve the right to give a partial refund in cases when the product(s) is not in an unused condition, is damaged or have missing parts not due to our error.

HOW RETURNS WORK:

Contact us through the contact form on our website and attach the invoice to the message as a proof of purchase. And please also write the reason for return.

We will then get back to you as soon as possible with information on where to send the product(s).

As soon as we have received the product(s) and made an inspection we will inform you of our decision.

If a refund is approved we will automatically credit the purchase to your credit card or original method of payment.

If the product(s) is damaged, not in its original condition or missing parts we will inform you if you are eligible for a partial refund. This is decided from case to case depending on the severity of the damages or what parts are missing.