

Fire Pit Table

If you have any questions about the product, please feel free to contact us.

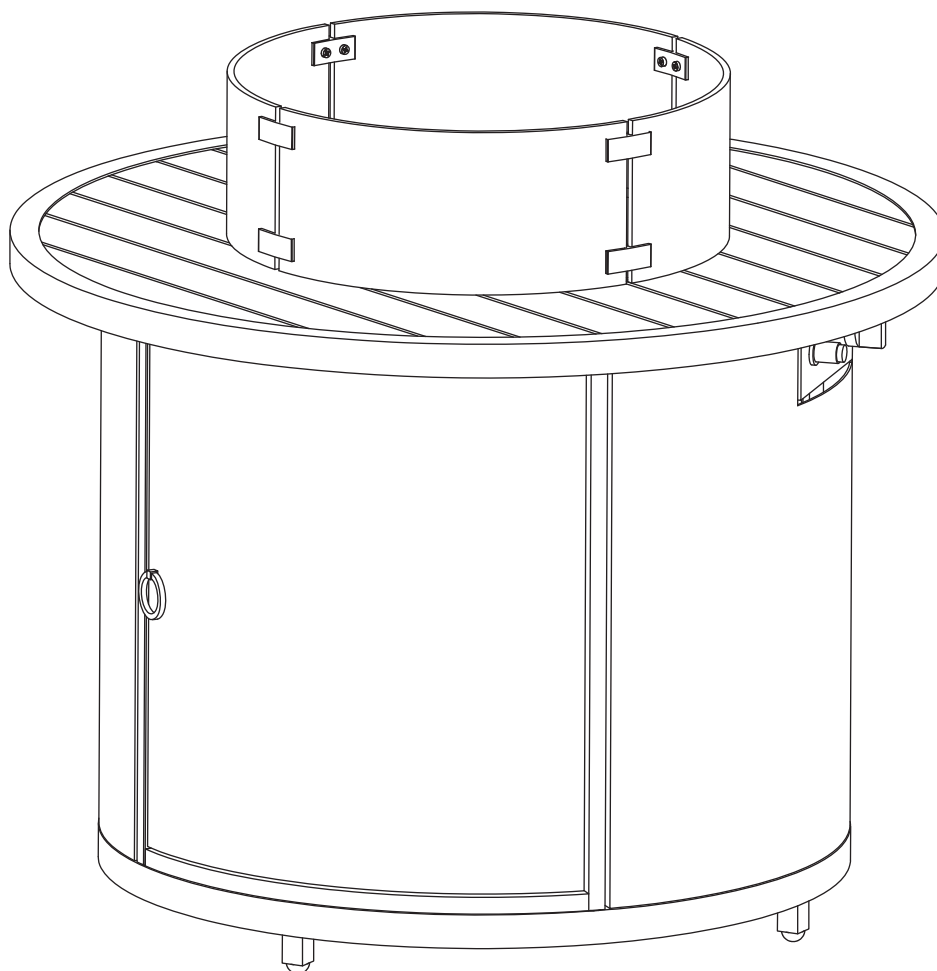

NOTICE



DANGER:

FIRE OR EXPLOSION HAZARD

If you smell gas:

- 1 Shut off gas to the appliance.
- 2 Extinguish any open flame.
- 3 If odor continues, leave the area immediately.
- 4 After leaving the area, call your gas supplier or fire department.

Failure to follow these instructions could result in fire or explosion, which could cause property damage, personal injury, or death.

WARNING:

Do not store or use gasoline or other flammable vapors and liquids in the vicinity of this or any other appliance.

An LP-cylinder not connected for use shall not be stored in the vicinity of this or any other appliance.

WARNING: For outdoor use only.

Installation and service must be performed by a qualified installer, service agency, or the gas supplier.

INSTALLER : Leave this manual with the appliance.

CONSUMER : Retain this manual for future reference.

DANGER



CARBON MONOXIDE HAZARD

This appliance can produce carbon monoxide which has no odour. Using it in an enclosed space can kill you. Never use this appliance in an enclosed space such as a camper, tent, car, or home.

WARNING:

If the information in this manual is not followed exactly, a fire or explosion may result causing property damage, personal injury, or loss of life.

WARNING:

Improper installation, adjustment, alteration, service or maintenance can cause injury or property damage. Read the installation, operating and maintenance instructions thoroughly before installing or servicing this equipment.

NOTICE



WARNING! HOT SURFACE!



GLASS. FRAGILE!



HANDLE WITH CARE



HEAVY OBJECT.
TWO PERSON LIFT REQUIRED.



LP SAFETY:

- Do not store a spare LP-gas cylinder under or near this appliance.
- Never fill the cylinder beyond 80 percent full.
- If the information in "(a)" and "(b)" is not followed exactly, a fire causing death or serious injury may occur. Do not use this appliance under overhead combustible surfaces.

MINIMUM CLEARANCES:

- Bottom: Non-Combustible Surface
 - Top: 60 inches
 - Sides: 36 inches
 - For Installation on (or over) non-combustible floors only
- Max. Input: 50,000 Btu/h
Max. Gas Supply Pressure: 250PSI
Min. Gas Supply Pressure: 25PSI

This appliance shall be used only outdoors in a well-ventilated space and shall not be used in a building, garage or any other enclosed area.

If this appliance is not in use, the gas must be turned off at the supply cylinder.

Indoor storage of this appliance is permissible only if the cylinder is disconnected and removed from the appliance.

Cylinders must be stored outdoors in a well-ventilated area out of the reach of children.

Disconnected cylinders must have threaded valve plugs tightly installed and must not be stored in a building, garage or any other enclosed area.

The gas pressure regulator provided with this appliance must be used, and must be the same model as supplied with the unit.

The cylinder supply system must be arranged for vapor withdrawal.

Cylinders used with this unit must have a collar to protect the cylinder valve.

An approved LP-Cylinder stabilizer, such as the stabilizer ring included, must be used when the appliance is in use.

NOTICE



LP CYLINDER:

All LP cylinders to be used with this appliance must be:

- a. Constructed and marked in accordance with the specifications for LP-gas cylinders Standard, CAN/CSA B339, Cylinders, Spheres and Tubes for the Transportation of Dangerous Goods.
- b. Provided with a listed overfilling prevention device.
- c. Provided with a cylinder connection device compatible with the connection for outdoor cooking appliances.
- d. Only a 20 lb. (9 kg) LP gas cylinder is to be used for this appliance, approximately 18" (46 cm) high & 12" (30 cm) diameter.
- e. The use of an approved LP gas cylinder stabilizer, such as the one included, must be used when using this appliance in order to prevent the LP gas cylinder from tipping over.

WARNING:

Please ensure that all adults and children who use or are near a unit in use are aware of the hazard of high surface temperatures present on the unit during use and should use caution and stay away to avoid burns or clothing ignition.

Carefully supervise young children in the area of this appliance. Clothing or other flammable materials should not be hung from the appliance or placed on or near the appliance. Any guard or other protective device removed for servicing the appliance must be replaced prior to operating the appliance.

Installation and repair should be done by a qualified service person. The appliance should be inspected before use and at least annually by a qualified service person. More frequent cleaning may be required as necessary. It is imperative that control compartment, burners and circulating air passageways of the appliance be kept clean.



CONNECTION:

1. Be sure the cylinder valve and appliance valves are "off".
2. Place full LP gas cylinder on tank stabilizer ring. Secure the base of the LP gas cylinder by hand tightening the wing-nut collar.
3. Center the nipple in the cylinder valve and hold in place.
4. Using the other hand, turn the hand wheel clockwise until there is a positive stop. Do not use tools.
5. Hand tighten only. When making the connection, hold the regulator in a straight line with the cylinder valve, so as not to cross thread the connection.
6. Leak test the connection.

DISCONNECTION:

1. Be sure the cylinder valve and appliance valves are "off" before disconnection.
2. Using one hand, turn the hand wheel anticlockwise.

LEAK TEST:

1. DO NOT USE OR PERMIT SOURCES OF IGNITION IN THE AREA WHILE DOING THE LEAK TEST. THIS INCLUDES SMOKING.
 2. Leak testing should be done once per year or whenever the LP gas cylinder or any other gas system part is taken apart, serviced or replaced, whichever is more frequent.
 3. Ensure all gas system coupling joints are tight and properly attached.
 4. Prepare a leak testing solution of half liquid detergent and half water.
 5. Apply the solution to the LP gas delivery system at points as shown in illustration indicated on page 5 .
 6. The leak(s) must be stopped by tightening the loose joints, if possible, or by replacing the faulty parts(s) with the part(s) recommended by the appliance manufacturer.
- THE APPLIANCE IS NOT TO BE USED UNTIL ANY LEAK IS CORRECTED.

NOTICE



LEAK TEST: Apply the solution to the LP gas delivery system at points:
1. Fire Table Valve Coupling
2. Gas Hose Regulator
3. Cylinder Valve Coupling

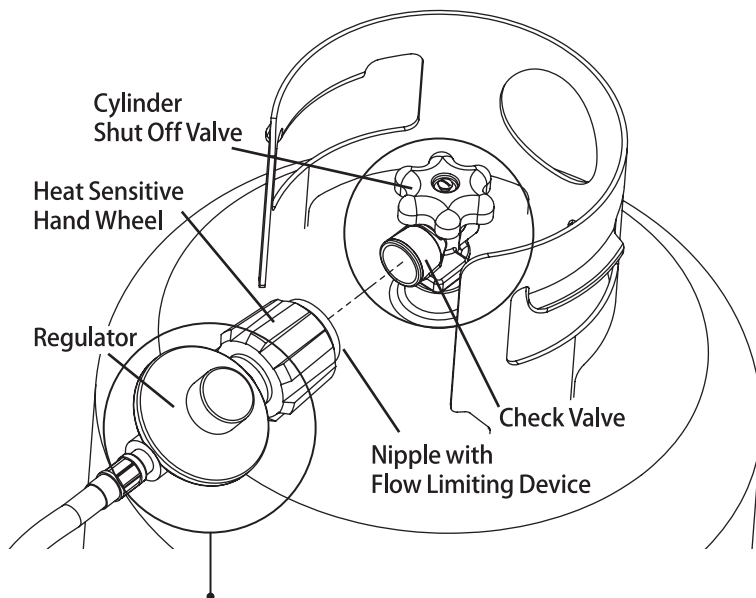
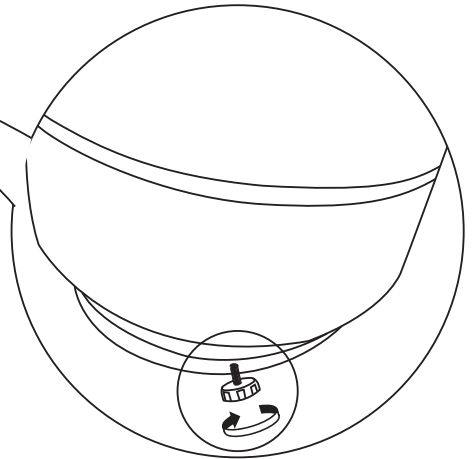
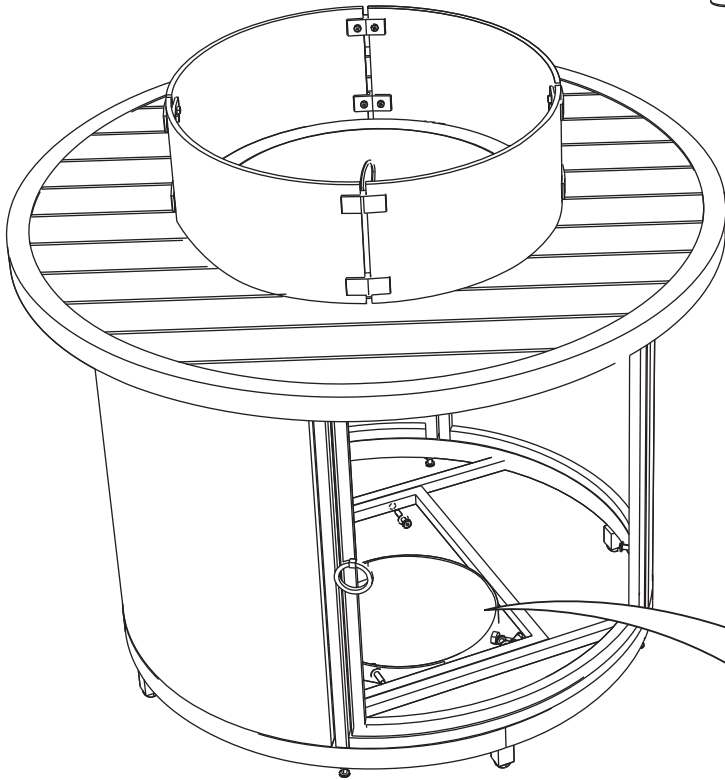
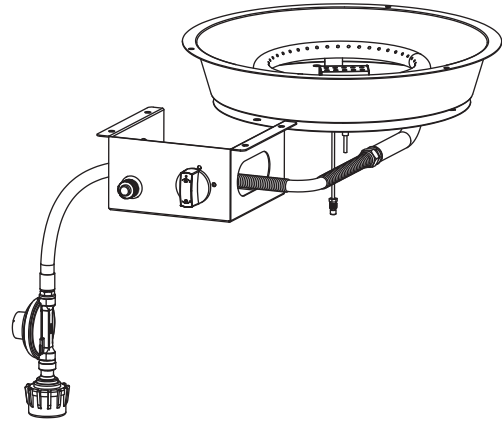

LEAK TEST: Apply the solution to the LP gas delivery system at points.
Fire Table valve coupling; gas hose regulator & cylinder coupling.



WARNING:

If the information in this manual is not followed exactly, a fire or explosion may result causing property damage, personal injury or loss of life. Installation and service must be performed by a qualified installer, service agency or the gas supplier.

THE APPLIANCE IS NOT TO BE USED UNTIL ANY LEAK IS CORRECTED.

A gas appliance repairman or LP gas dealer should be called if attempts to stop the leak(s) are unsuccessful and, in such case, the LP gas supply must be shut off at the cylinder valve or the cylinder must be removed from the appliance until the leak(s) is corrected.

Inspect hose prior to each use of the unit. To gain access for inspection remove the side panels. To remove each side panel, simply use pull rings and lift panel away. Refer to assembly instructions for visual diagrams. The hose assembly must be replaced prior to the appliance being put into operation if there is evidence of excessive abrasion or wear, or if the hose is damaged. Should you require a replacement hose. Replacement hose assembly shall be the one that is specified by manufacturer.

Inspect burner prior to each use. Burner must be replaced prior to the appliance being put into operation if there is evidence of damage.

Should any part of this appliance (including the burner) become soiled or dirty, wipe lightly with a damp cloth. Do not use flammable or corrosive cleaning products on or near this unit.

Ensure that gas hose is placed in an area where it is unlikely to be tripped over (such as pathways or trails) or subject to other accidental damage.

Keep the appliance area clear and free from combustible materials, gasoline and other flammable vapors and liquids.

Solid fuels shall not be burned in this appliance.

The installation must conform with local codes, or in the absence of local codes with the National Fuel Gas Code, ANSI Z223.1/NFPA 54; National Fuel Gas Code; Natural Gas and Propane Installation Code, CSA B149.1; or Propane Storage and Handling Code, CSA B149.2, as applicable.

NOTICE



Please retain these instructions for future reference.

Dear Customer

Thank you for your purchase.

When you receive the product, please make sure that all the parts are intact.







Then please browse the entire installation manual before assembly.

If problem occur unsatisfactorily as follows

- A** . The outer box is damaged
- B** . The product is damaged / bent / cracked while you open the box
- C** . The parts / accessories / assembly tools are missing
- D** . The product is hard to assemble
- E** . The instructions are not clear and can not be referred
- F** . The product has functional problems
- G** . Other aspects that you are not satisfied with



Please do not hesitate to contact us for help. Our team with factory direct after-sales service will reply within 24 hours and will do our best to resolve the problem for you.

HARDWARE LIST

| Hardware List | | | | |
|--|--|--|--|---|
|  M6*15 Bolt |  M6*30 Bolt |  M6*45 Bolt |  Ø6*12 Washer |  Hex Wrench |
| 8 pc | 8 pc | 4 pc | 20 pc | 1 pc |
|  Hex Wrench |  M8*7 Screw | | | |
| 1 pc | 16 pc | | | |

PART LIST

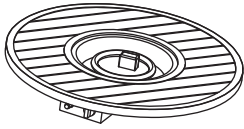
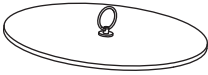
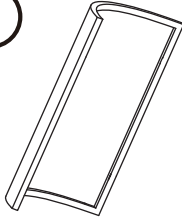
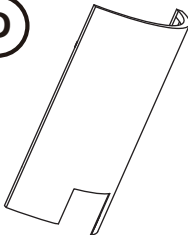
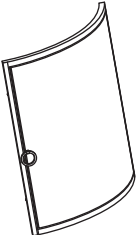
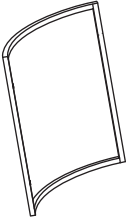
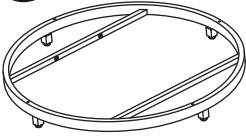
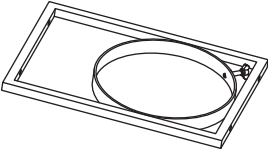

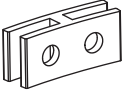
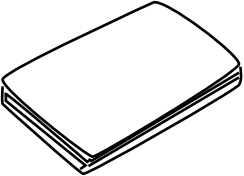
Parts List

| | | | | |
|---|---|---|--|---|
|  |  |  |  |  |
| 1 pcs | 1 pcs | 1 pcs | 1 pcs | 1 pcs |
|  |  |  |  |  |
| 1 pcs | 1 pcs | 1 pcs | 4 pcs | 8 pcs |
|  <p>Cover</p> | | | | |
| 1 pcs | | | | |

1. Please ensure that all accessories are complete before starting the installation.
2. Due to the variety of accessories, many accessories may be glued together, please check carefully
3. If any accessories are missing or damaged, please contact the seller immediately.

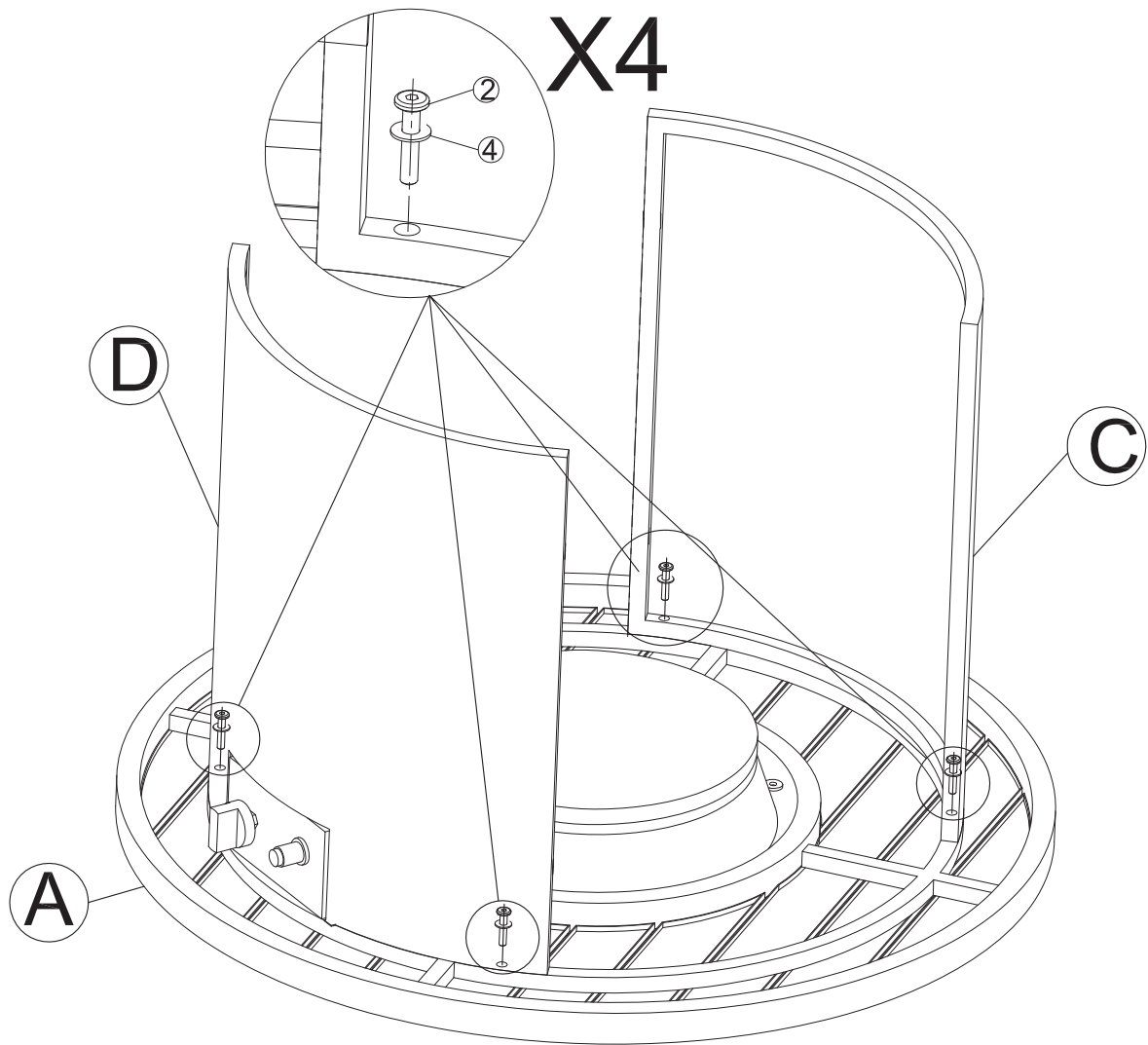

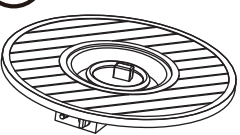
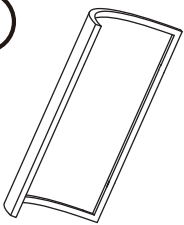
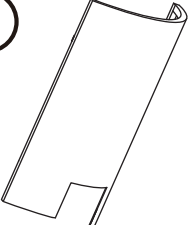
STEP 1



| | | | | |
|---|---|---|---|---|
|  |  |  |  |  |
| 1 pcs | 1 pcs | 1 pcs | M6*30 Bolt 4 pc | Ø6*12 Washer 4 pc |

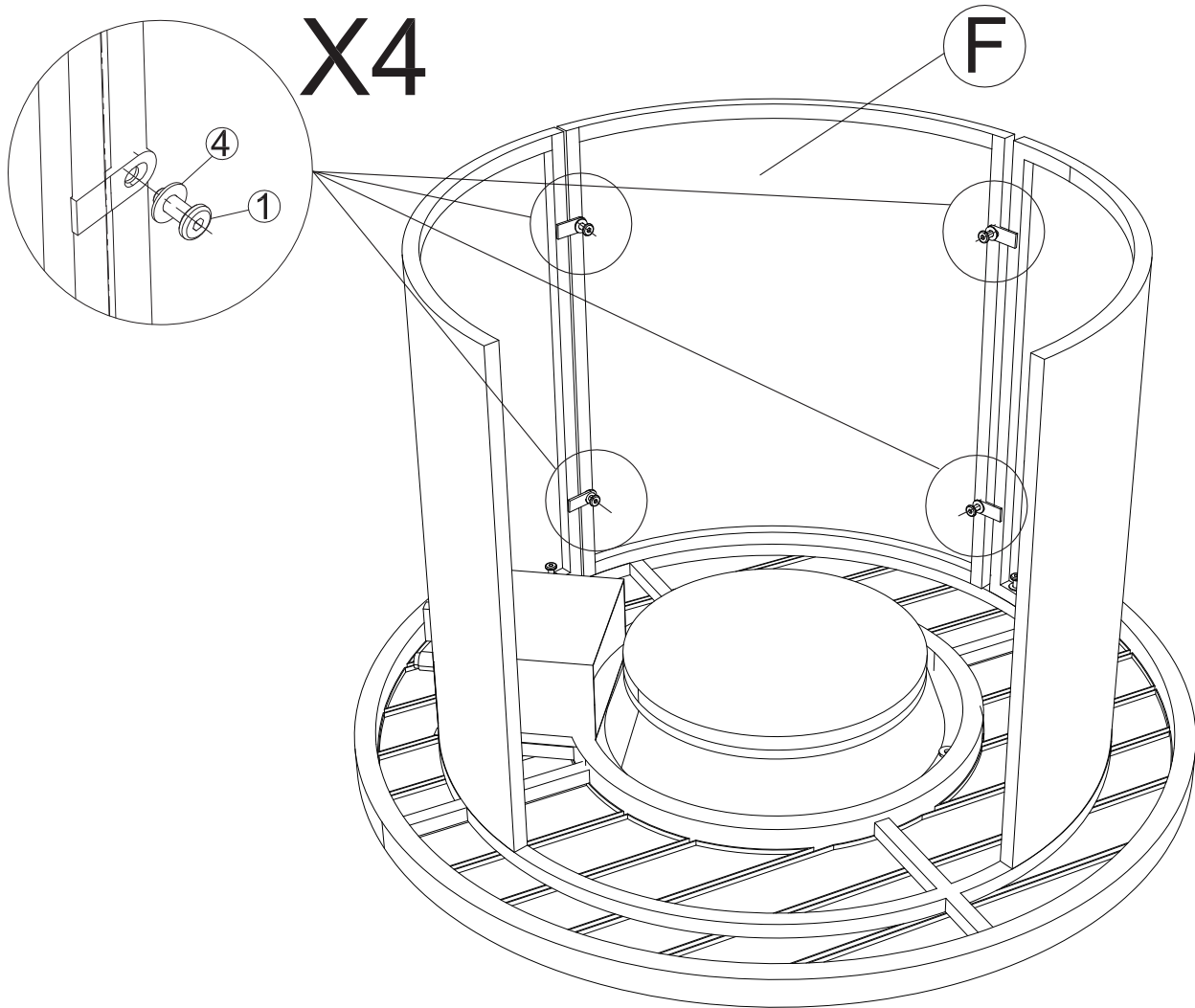

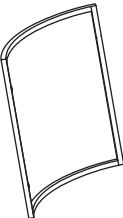
STEP 2

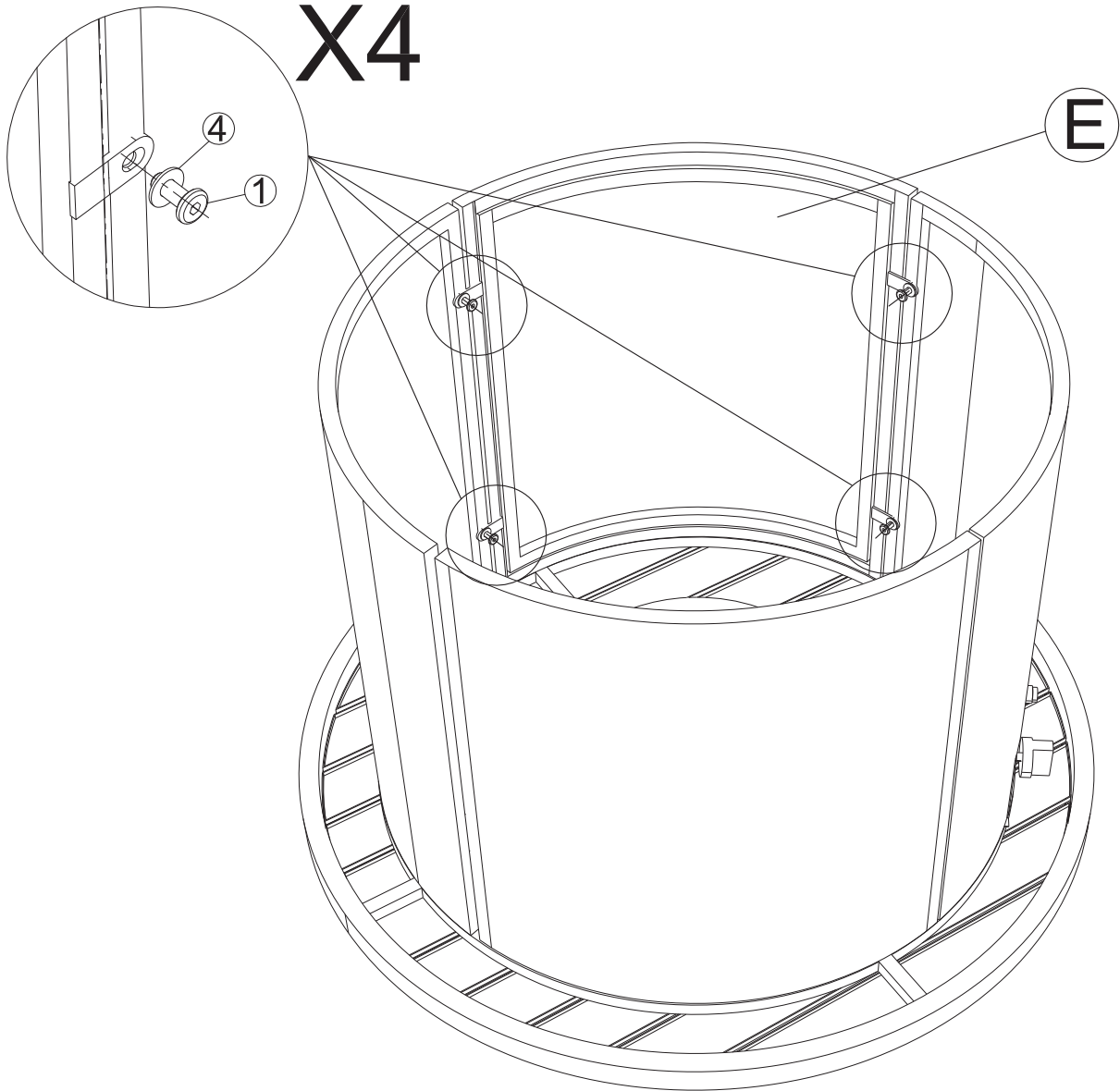

| | | |
|--|---|---|
|  F |  1 M6*15 Bolt |  4 Ø6*12 Washer |
| 1 pcs | 4 pc | 4 pc |

STEP 3

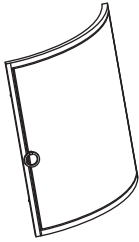

| | | |
|---|---|---|
|  <p>E</p> |  <p>1</p> <p>M6*15 Bolt</p> |  <p>4</p> <p>Ø6*12 Washer</p> |
| 1 pcs | 4 pc | 4 pc |

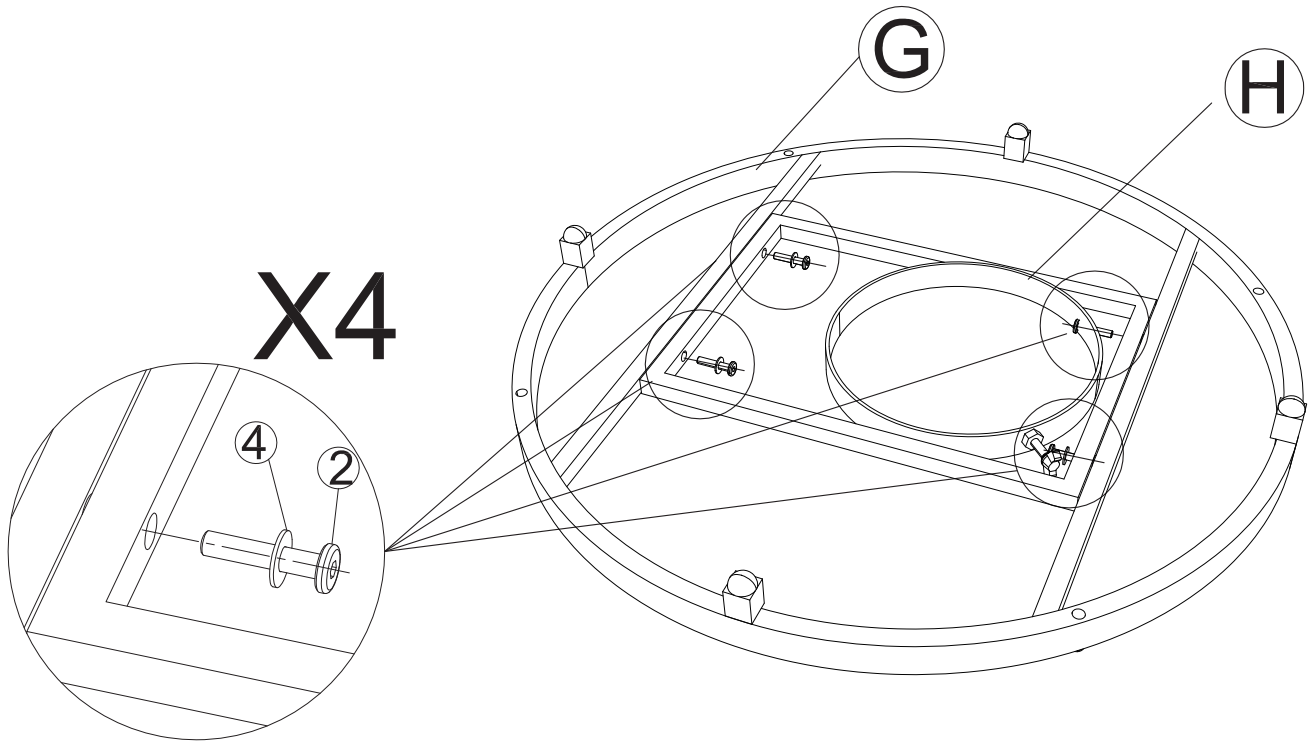

STEP 4

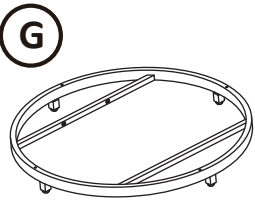
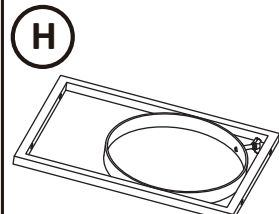
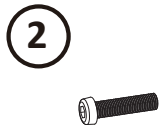
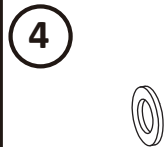

| | | | |
|---|---|--|---|
|  |  |  |  |
| 1 pcs | 1 pcs | M6*30 Bolt | Ø6*12 Washer |
| | | 4 pc | 4 pc |

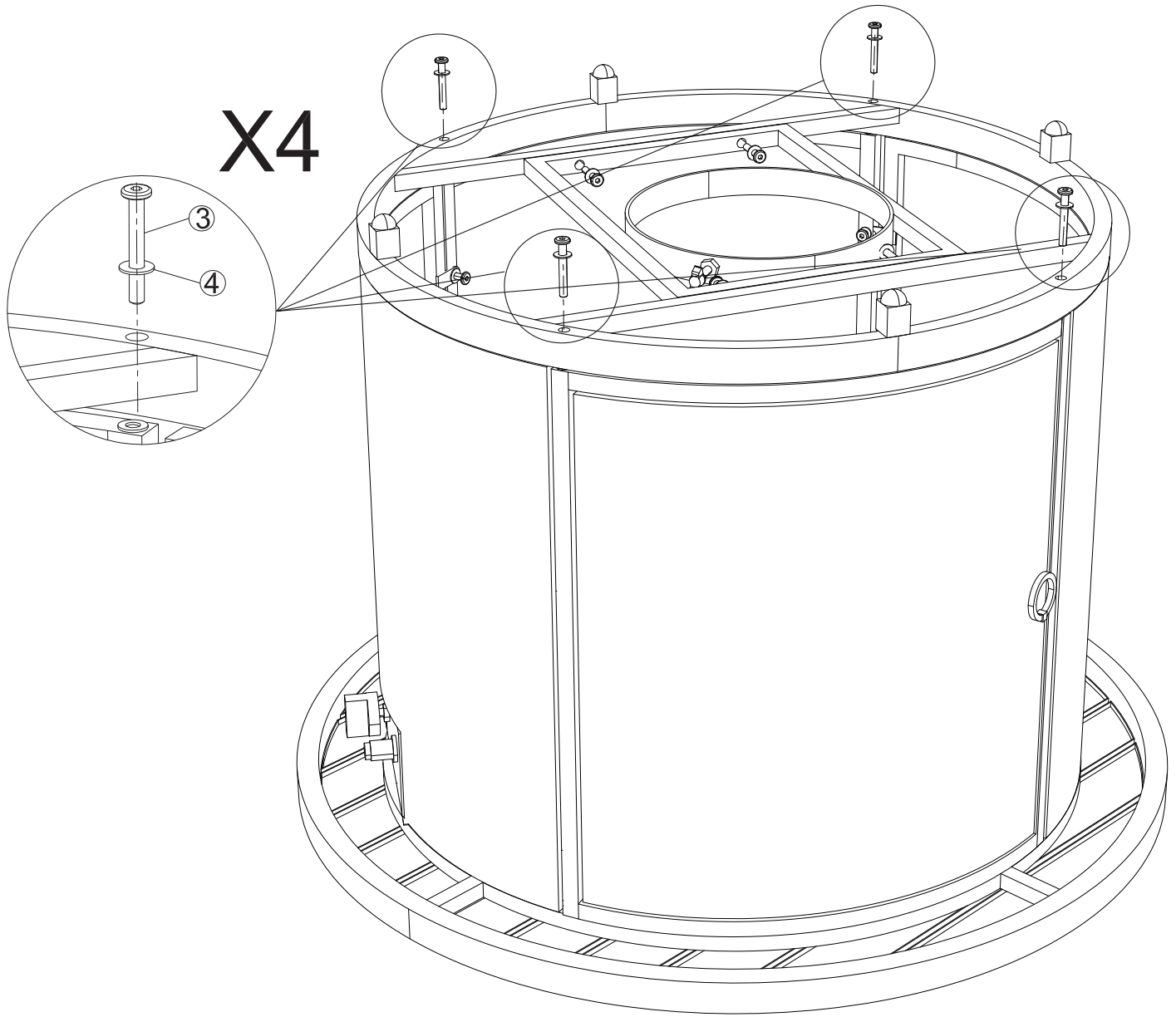
STEP 5



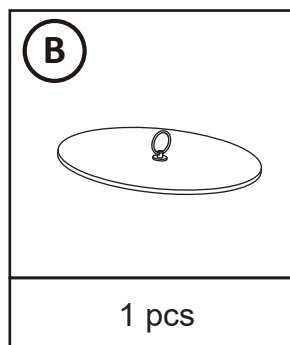
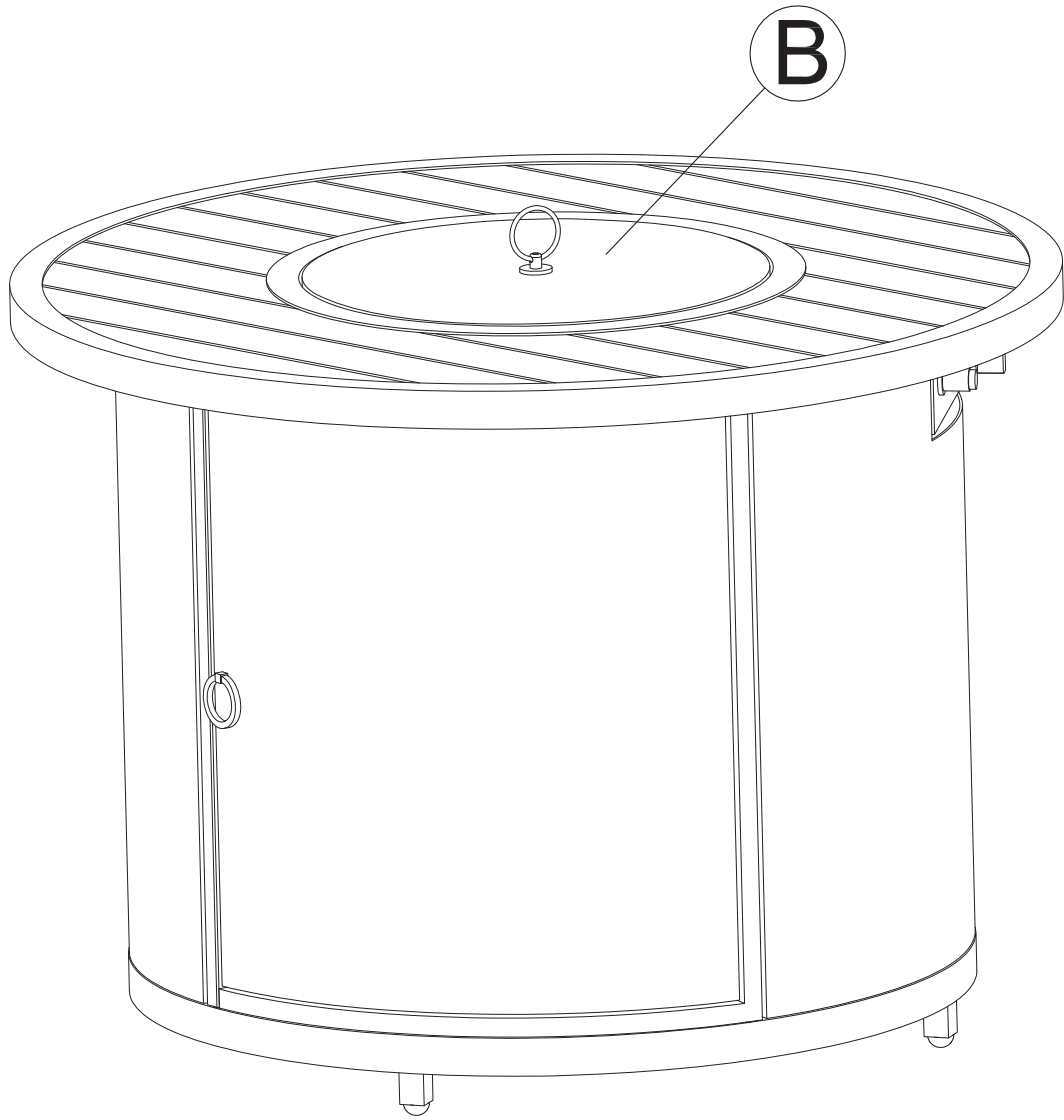

| | |
|--|---|
| 3  M6*45 Bolt | 4  Ø6*12 Washer |
| 4 pc | 4 pc |

STEP 6

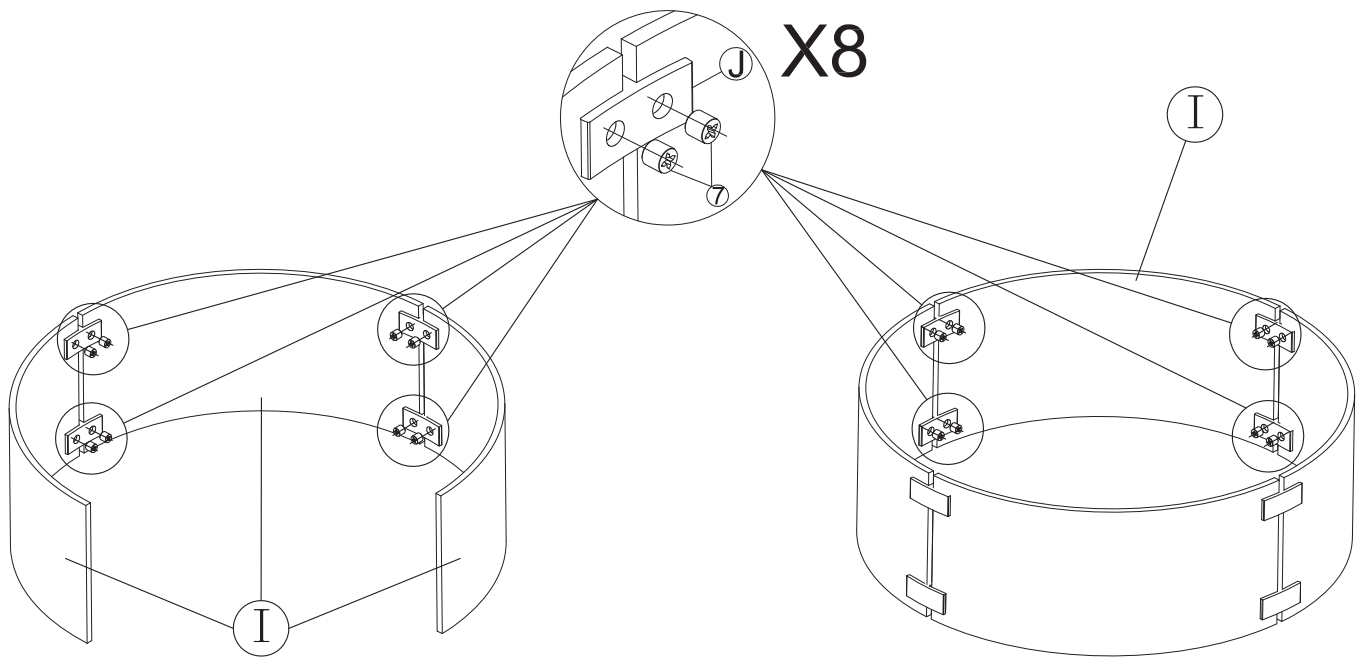

STEP 7

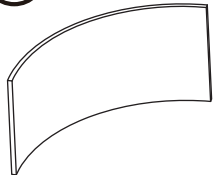
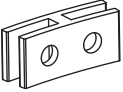

| | | |
|--|--|--|
|  <p>I</p> |  <p>J</p> |  <p>7</p> <p>M8*7 Screw</p> |
| 4 pcs | 8 pcs | 16 pcs |

STEP 8

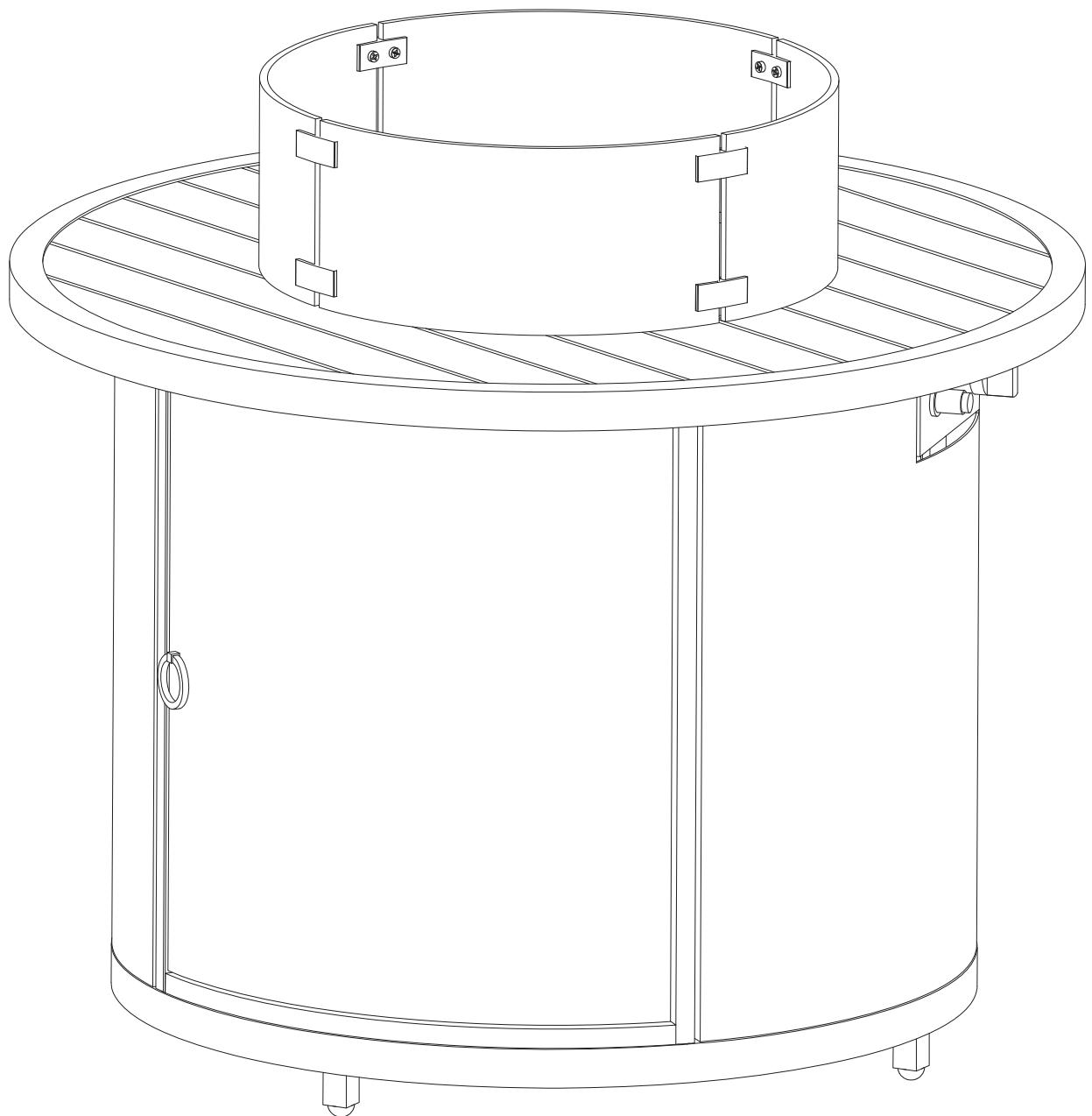

AFTER-SALE SERVICE CARD

If you have any suggestions for our products or find that the products have quality problems, please contact us first, our after-sales team will reply you within 24 hours, and we will do our best to give you solutions until you are satisfied.

Guaranteed Customer Service

Your shopping experience is very important to us!
Feel unsatisfied? **Contact us!**
Have any questions? **Contact us!**

Wanna Share how wonderful our smart products makes your home?
Share your pictures with us.
Any suggestions? **Contact us!**
We gotcha back!