

ASSEMBLY INSTRUCTIONS

2D Floor Cabinet

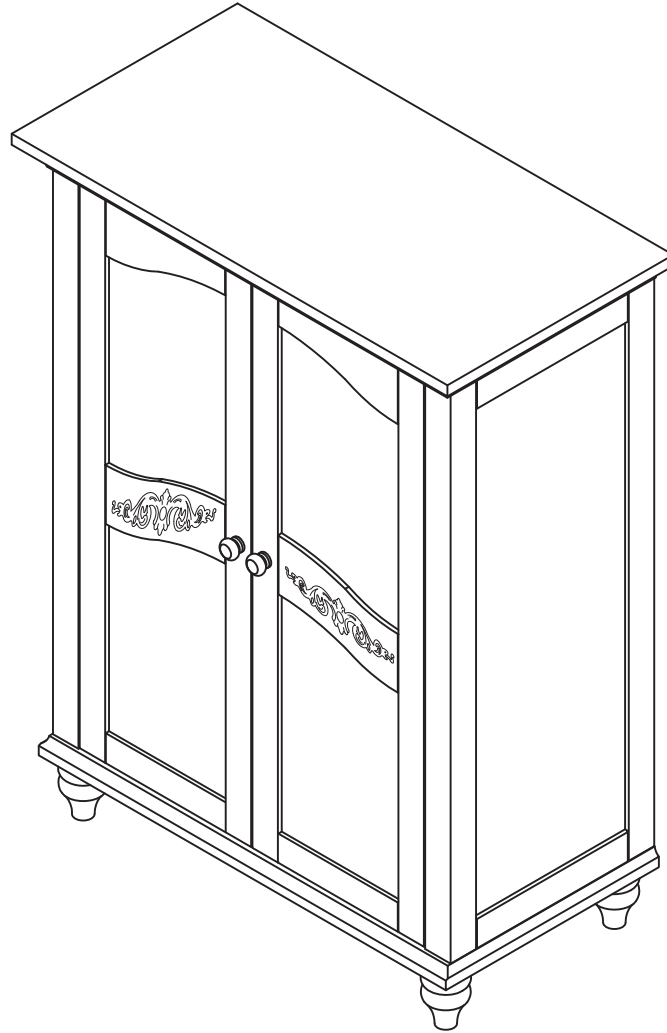

ASSEMBLY INSTRUCTIONS-IMPORTANT

Carefully unpack & identify each component before attempting to assemble. Refer to parts list. Please take care when assembling the unit and always set the parts on a clean, soft surface. If you require any assistance with assembly, parts, please call the company you place order









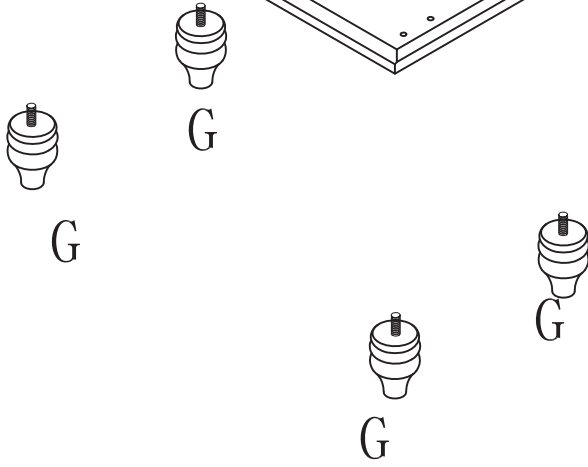
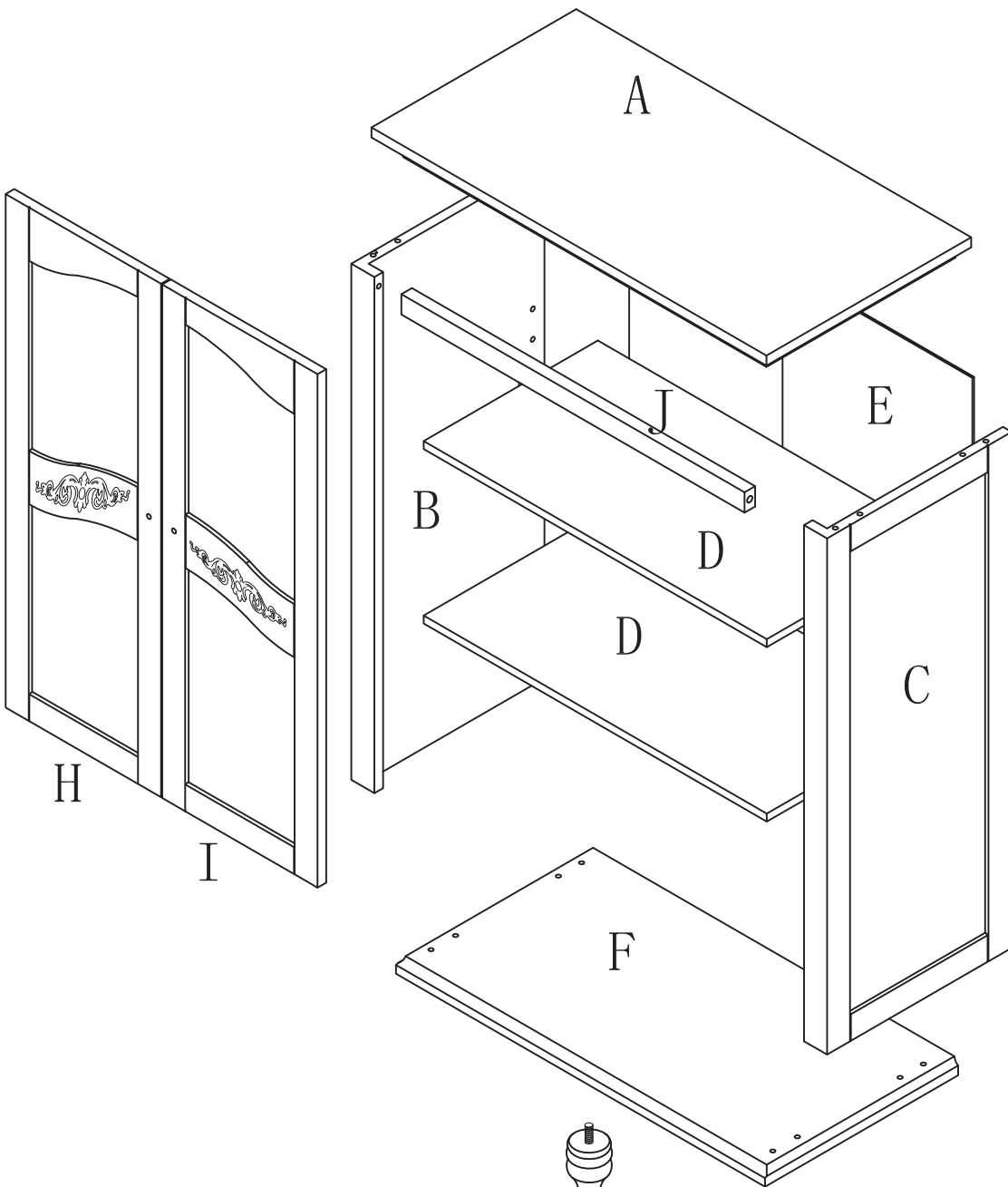

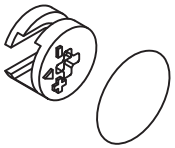
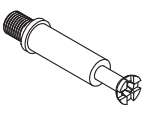
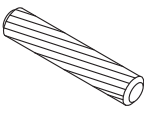
INSTRUCCIONES PARA ARMAR-IMPORANT:

Desempaque cuidadosamente e identifique cada componente antes de tartar de empezar su ensambladura. Verifique la lista de partes. Por favor tenga cuidado cuando arme la unidad y siempre coloque las piezas sobre una superficie plana, suave y limpia.

DIRECTIVES DE MONTAGE-IMPORTANT:

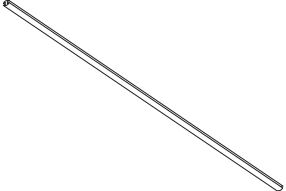
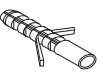
Avant de commencer l' assemblage, déballez délicatement toutes les pièces et repérez-les sur la liste des pièces. Procédez avec soins durant l' assemblage et posez toujours les pièces sur une surface proper, douce et lisse.



<p>①</p>  <p>8PCS</p>	<p>②</p>  <p>8PCS</p>	<p>③</p>  <p>12PCS</p>
<p>④</p>  <p>8PCS Ø3*12MM</p>	<p>⑤</p>  <p>2PCS</p>	<p>⑥</p>  <p>2PCS</p>
<p>⑦</p>  <p>8PCS</p>	<p>⑧</p>  <p>16PCS Ø3*12MM</p>	<p>⑨</p>  <p>1PC</p>
<p>⑩</p>  <p>1PC</p>	<p>⑪</p>  <p>1PC</p>	<p>⑫</p>  <p>2PCS</p>
<p>⑬</p>  <p>2PCS Ø4*25MM</p>		

STEP 1
ÉTAPE 1
PASO 1

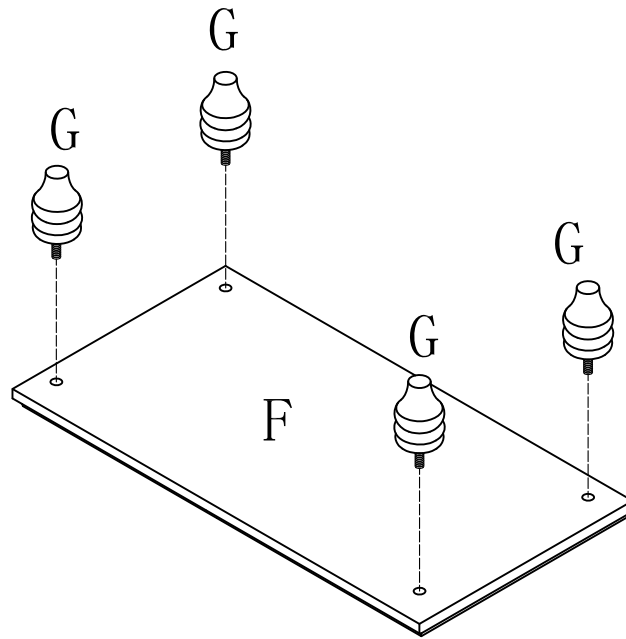

STEP 2
ÉTAPE 2
PASO 2

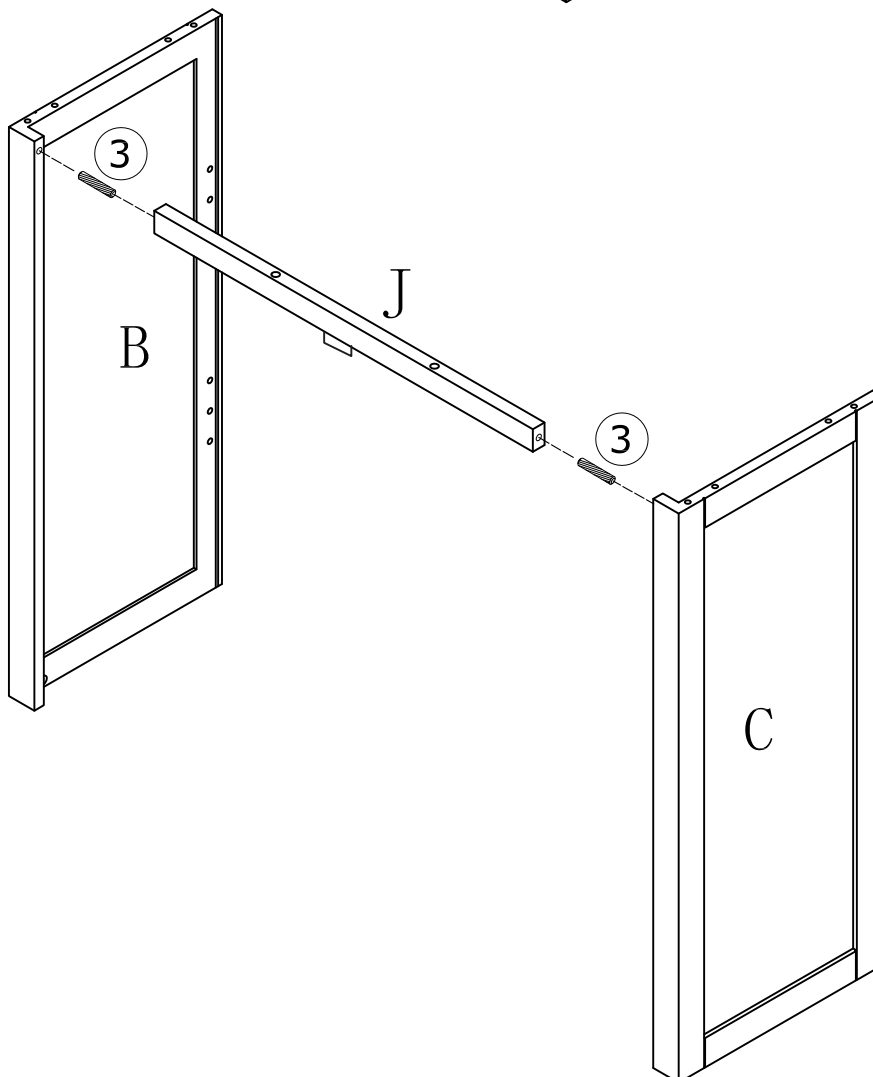

STEP 3
ÉTADE 3
PASO 3

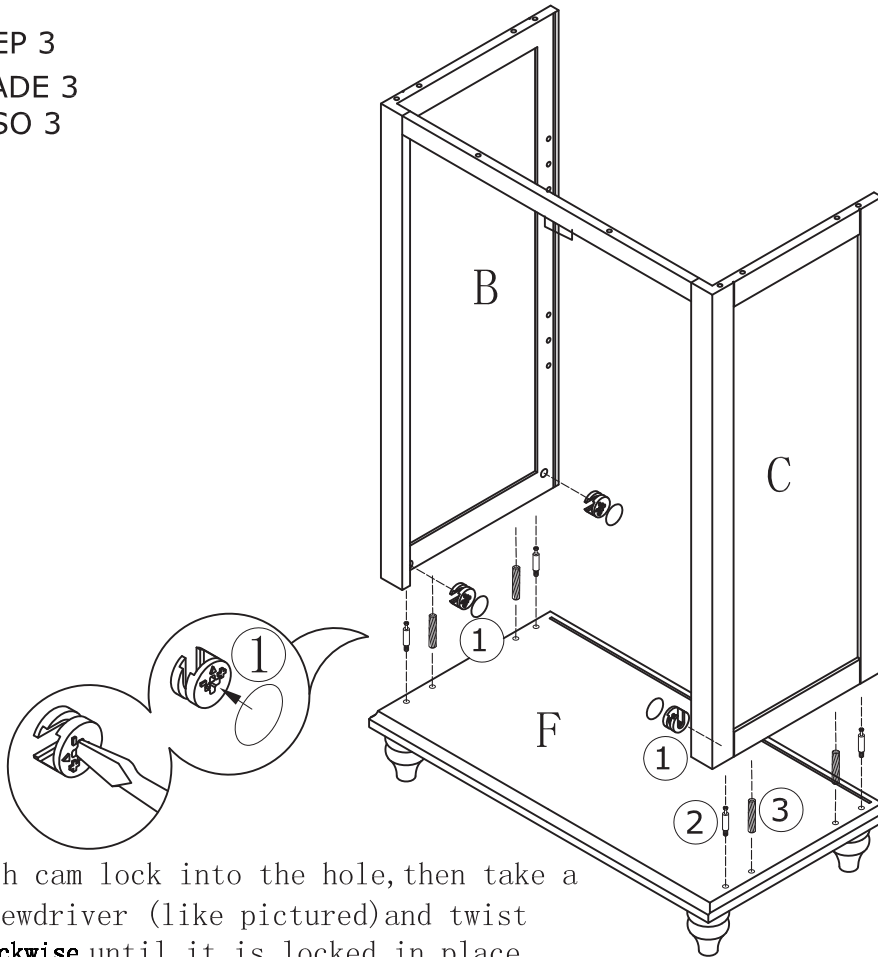

Push cam lock into the hole, then take a screwdriver (like pictured) and twist **clockwise** until it is locked in place.

STEP 4
ÉTADE 4
PASO 4

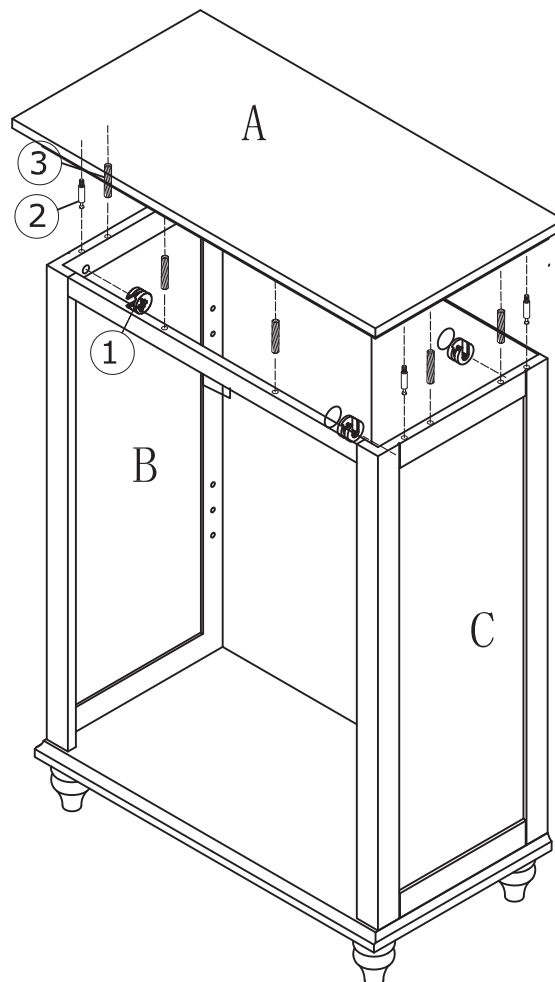

STEP 5
ÉTAPE 5
PASO 5

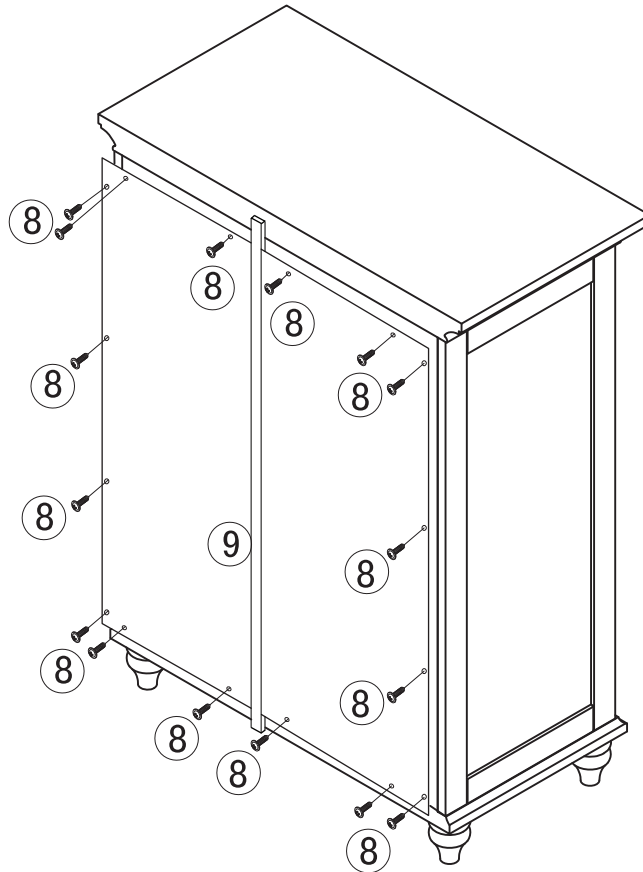

STEP 6
ÉTAPE 6
PASO 6

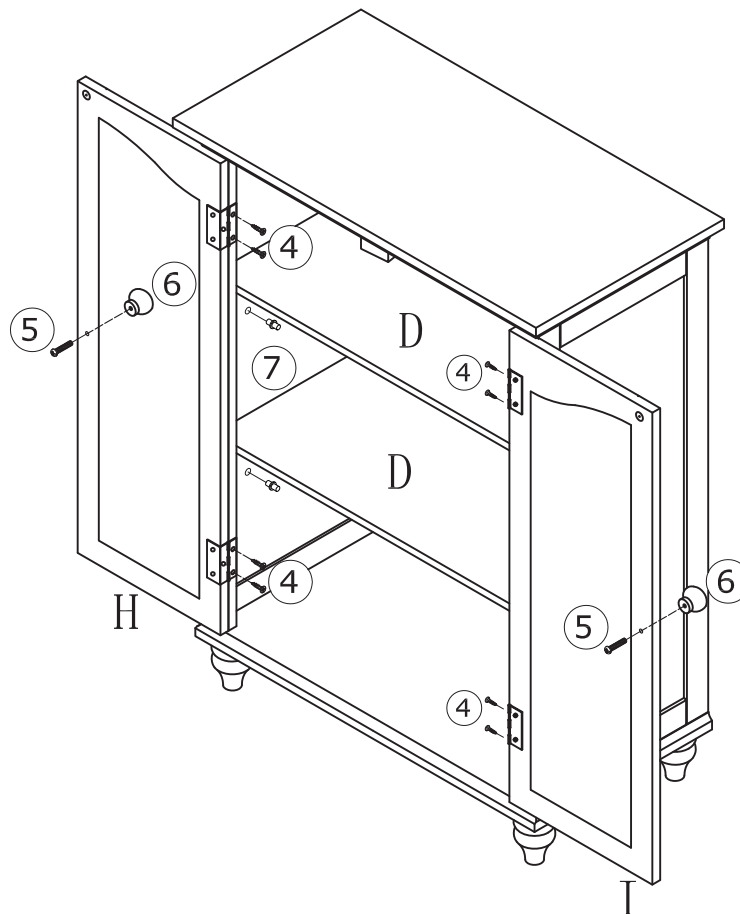

STEP 7
ÉTAPE 7
PASO 7

