

# User's Manual

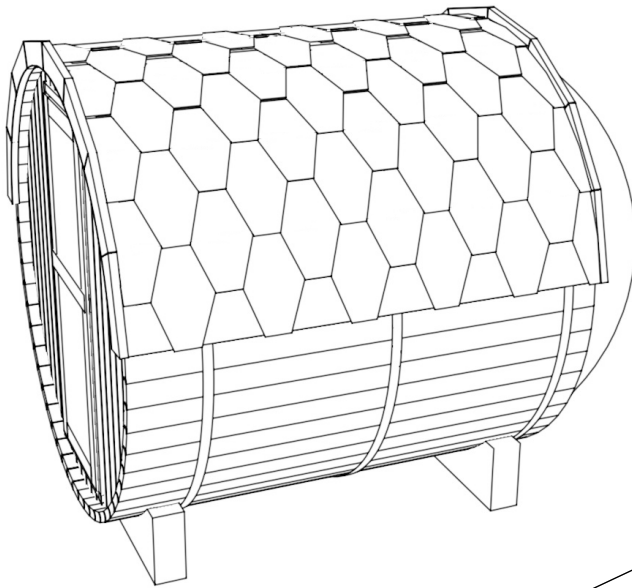

SMT-HSR1815A/SMT-HSR1818A/  
SMT-HSR1824A  
Series without porch

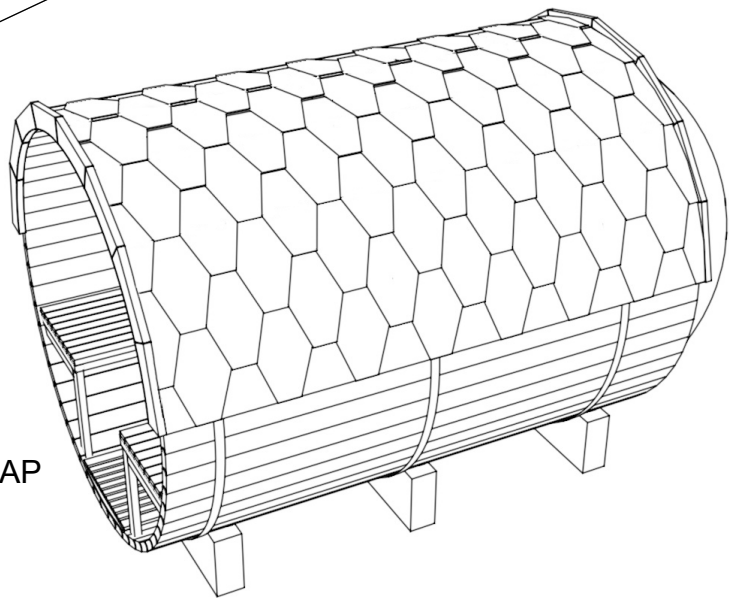

SMT-HSR1818AP/SMT-HSR1824AP  
Series with porch

# Contents

<b>Sequences and contents of sauna assembly</b>	<b>Page</b>
Instructions before Use .....	- 3 -
1.Base Assembly .....	- 6 -
2.Front and Back Wall Assembly .....	- 7 -
3.Stave Assembly .....	- 8 -
4.Accessories installation .....	-10-
5.Sauna heater fence and lamp assembly(Lamp is optional) .....	-11-
6.External waterproofing installation .....	-12-
Asphalt shingles installation .....	-13-
Wood shingles installation .....	-14-
7.Filled with waterproof glue .....	-14-
8.Instructions .....	-15-

## Instructions before Use



1. A member of the high blood pressure, heart disease, high blood pressure do not Sauna.
2. Who has a cold should not be sauna. because the sauna room hidden cryptococcus bacteria can enter human body through respiratory tract, such as easy to cause pneumonia, etc.
3. Do not sauna when overwork and can't sleep in sauna room. People with poor muscle tone when they are tired, reduce the stimulation of cold and hot resistance ability, easy to cause collapse when sauna.
4. Do not sauna when on an empty stomach, lest cause cardiovascular collapse. Should not be sauna after overstrain brain or strenuous exercise, it can cause brain anemia or shock.
5. It is not suitable for sauna not after half an hour feast, because the high temperature make the skin vasodilation, blood backflow in great quantities, which affects the blood supply of the digestive organs, interfere with digestion and absorption of food.
6. Do not sauna after drinking. After heavy drinking, it can make the brain systems at the mercy of the function to drop, at this time if sauna, under the effect of alcohol, a amount of sweat will make human body caused by rapid filtration syncope.
7. Do not wear jewelry when sauna, like jade, necklaces, watches, etc are easy absorption of heat may be burn the skin.
8. Do not apply cosmetics, because it can block pore, prevent sweat evaporation.
9. Sauna is not suitable for the elderly, sitting in a sauna room, the body sweat more, the blood becomes sticky, it is easy to form thrombus, cause of various cardiovascular diseases. Especially the elderly, their body temperature regulating center not too sensitive, so not suitable for sauna.
10. Sauna should not be too long, if too long, excessive sweating can make the person to exhaustion; temperature is too high, can be difficulty breathing. In general, in the sauna room should be come out every 5-10 minutes. Setting temperature personalized, it is recommended that the dry steam temperature between 60°C to 80°C make the person feels more moderate.
11. Do not immediately come with cold air after sauna, prevent big difference temperature cause vascular contractions induced stroke.
12. Go with partner sauna, should be timely supplement moisture, do not wait until thirsty to drink.
13. Keep awake when sauna, if have shortness ofbreath, dizziness and other symptoms should immediately stop sauna, lie down in a better air circulation place, drink some cold boiled water, not drink too low water temperature.
14. Do not get up too fast and too hard, be sure slow up and adequate rest.

# Introduction:

## Instructions before assembly

1. At least two people are required to assemble the sauna.
2. Assembly location: check whether the ground or platform is horizontal, and slight slope will not affect the assembly and use of sauna, but if the slope is evident, a pad is needed to keep the sauna level.
3. All screw heads to assemble sauna must be completely inserted into wood to avoid scratching skin during use. If you want to assemble accessories provided by other companies to the sauna, try to avoid metal accessories, or insulate them.
4. Please find qualified electricians to install the electrical elements in sauna.

## 1. Tools we prepare

Plastic Hammer × 1	Glue gun × 1	Waterproof glue
		

## 2. Tools you need to prepare

Power Drill x 1	Adjustable Wrench x 2	Tape x 1	U-shaped nail gun x 1	Scissors/Utility Knife x 1	Herringbone ladder x 1
					
Bar Level × 1					
					

## 3. All parts list

Accessories package List							
NO.	Component	Unit	Model/ numbers				
			SH1815A	SH1818A	SH1818AP	SH1824A	SH1824AP
1	Power/Voltage	Pc	220V/4.5KW	220V/6.0KW			
2	Bucket	Pc	1	1	1	1	1
3	Sauna Stones	Ctn	1	1	1	1	1
4	Thermometer /Hygrometer	Pc	1	1	1	1	1
5	Explosion-proof Lamp Holder	Pc	1	1	1	1	1
6	Ladle	Pc	1	1	1	1	1

# Wooden components of sauna

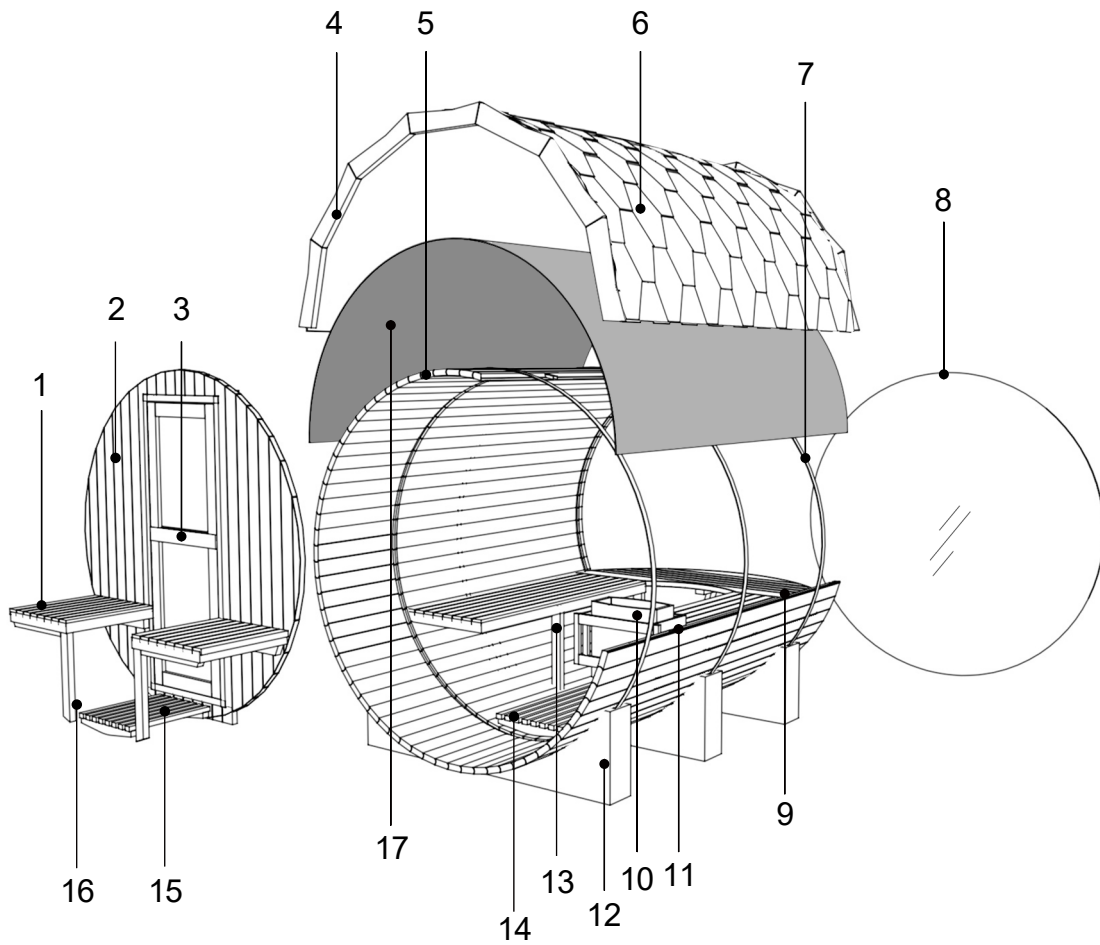

No.	Name	Quantity
1	Outside Bench(Series porch)	2
2	Front Wall	3
3	Door Handle	/
4	Decorative Plates	/
5	Stave	/
6	Shingles	1
7	Steel Ring	2-3
8	Panoramic Window	1

No.	Name	Quantity
9	Inside Bench	3
10	Heater Fence	1
11	Sauna Heater(Optional)	2
12	Base	2-3
13	Bevel Support	0-4
14	Inside Floor	1
15	Outside Floor(Series Porch)	1
16	Bevel Support(Series Porch)	2
17	Tarp	1

# 1. Base assembly step

- ① The length of A depends on 1 to 3 base blocks. The distance among bases can be distributed freely and equally by customers.

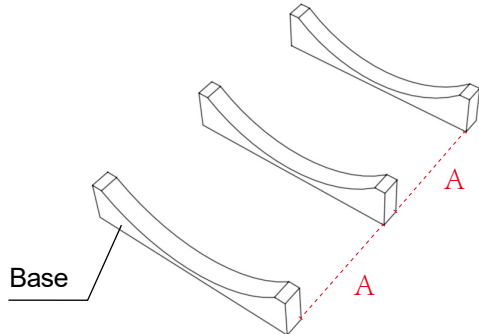

- ② Place the arc-shaped wooden strip with raised sides in the middle of the base and fix it with screws.

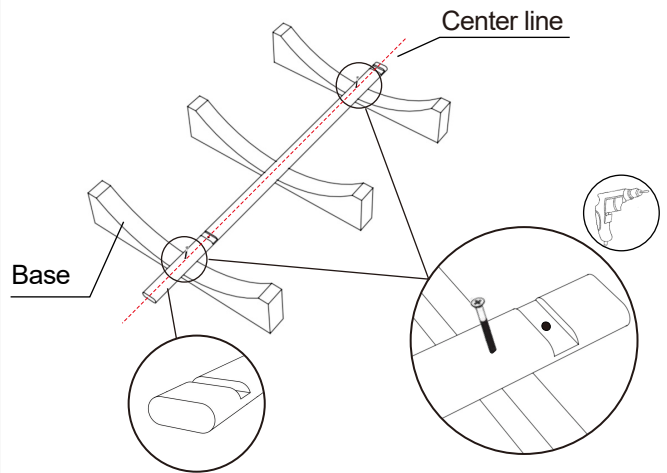

- ③ The wooden strip with holes will be placed first.

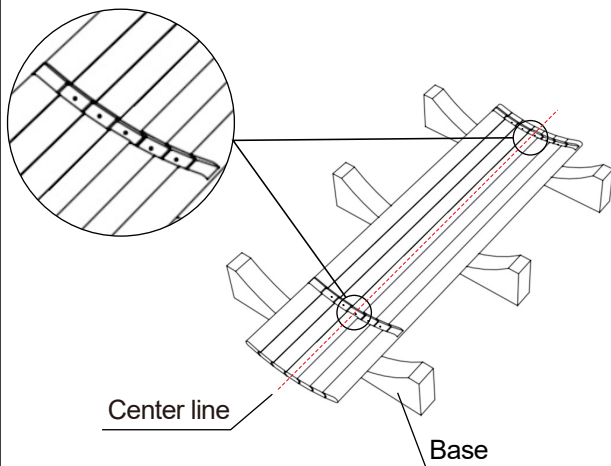

- ④ Fix the staves to the base with screws.

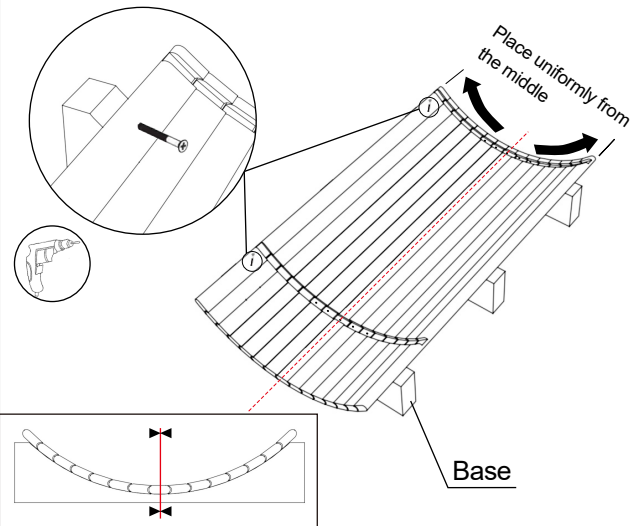

## 2. Front and back wall assembly

①

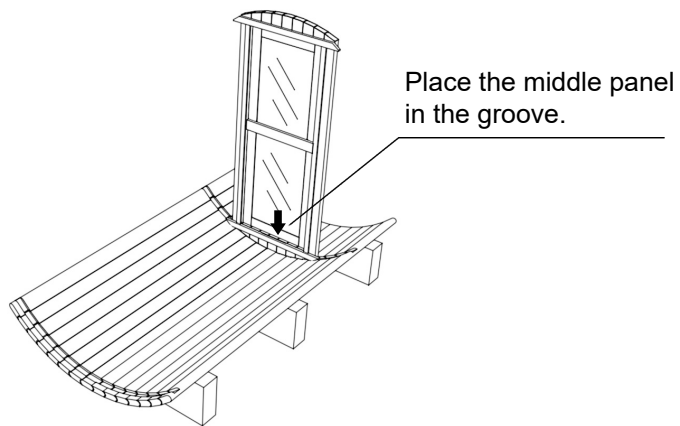

② Place the three panels of the front wall into the grooves.

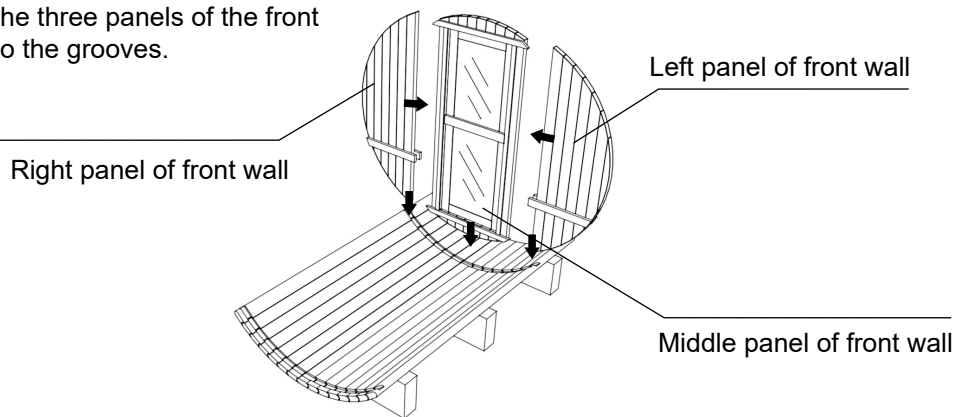

③

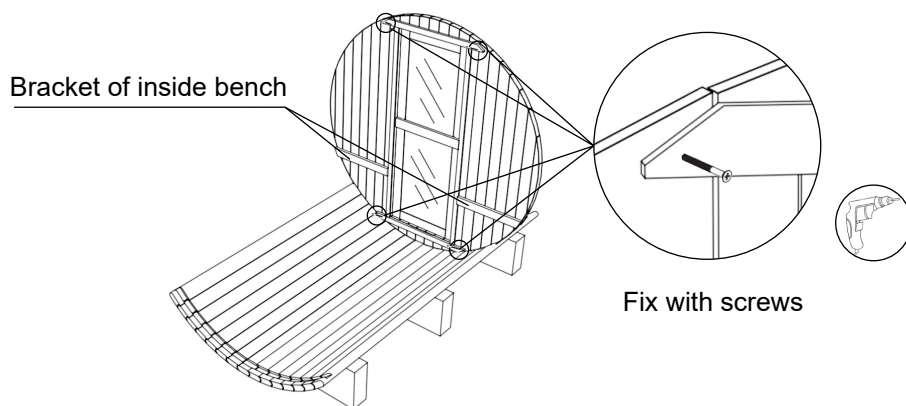

④

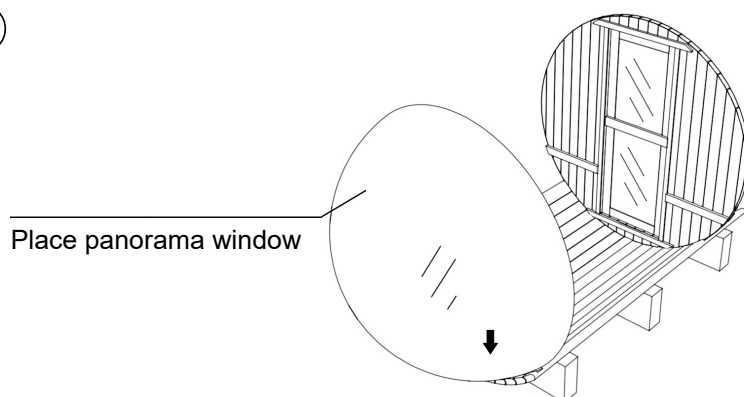

### 3. Stave assembly

- ① Place the level on the front wall to ensure the front wall is level.

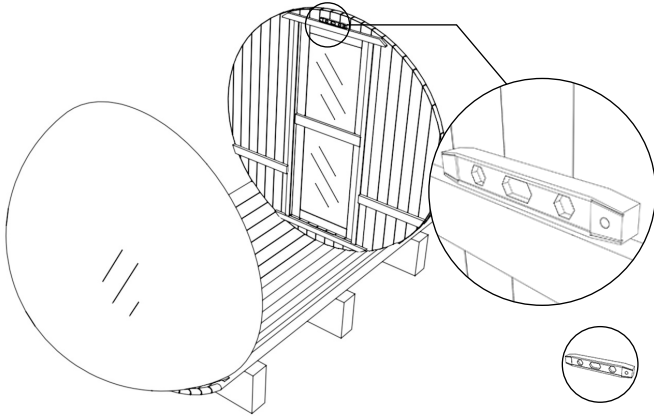

- ② When installing the staves in the lower half, use screws to secure the staves to the front wall.

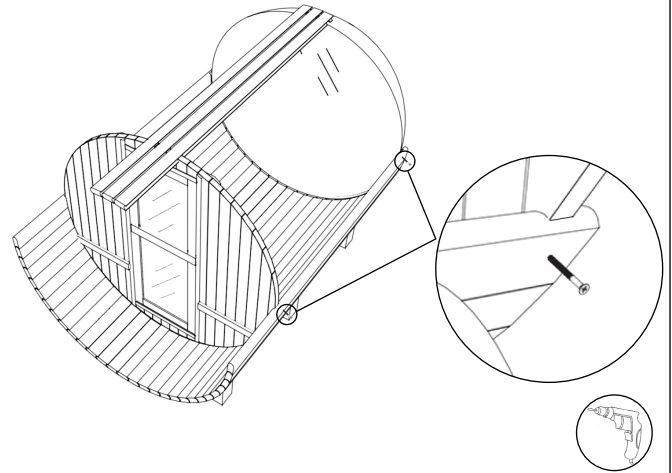

- ③

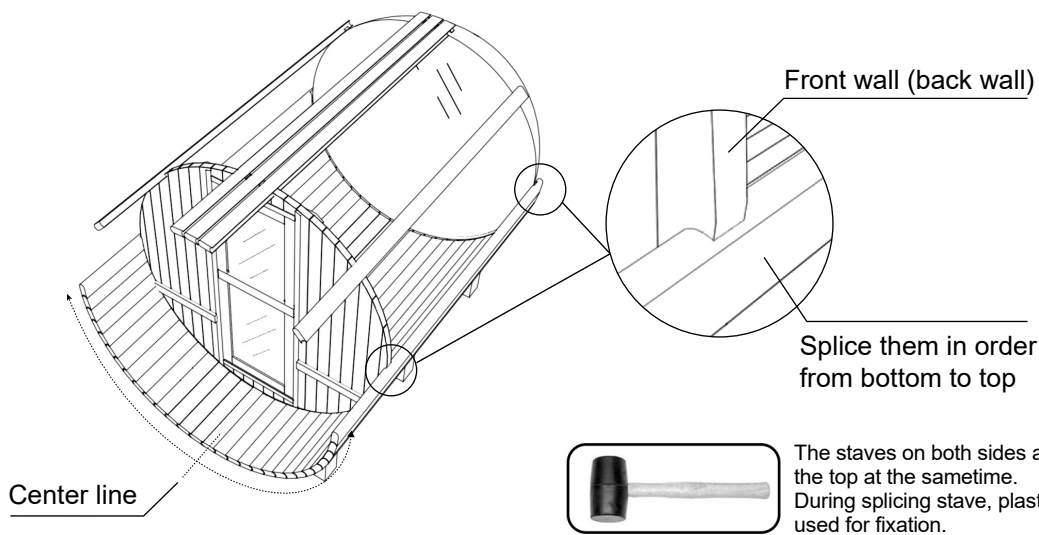

- ④

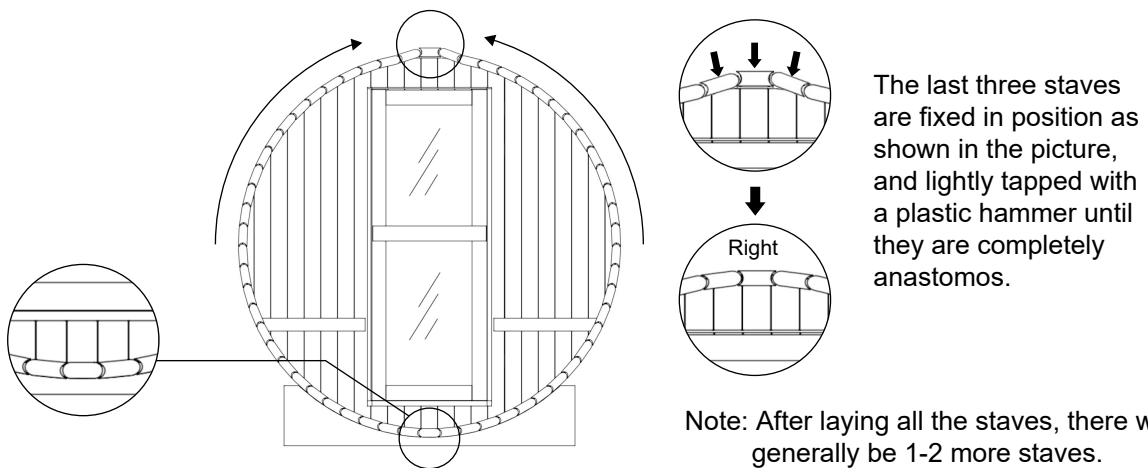

⑤ Connect the steel belts.

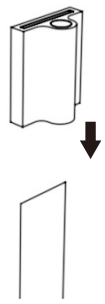

Pass the steel belt through the buckle.

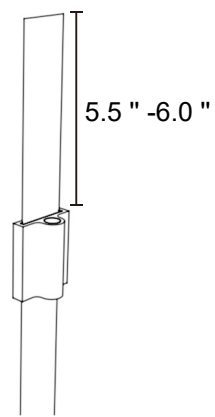

The length of the steel belt passing through the buckle is 5.5 " -6.0 ".

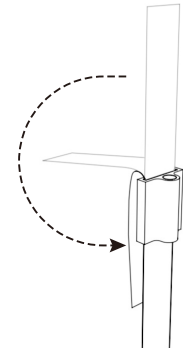

Fold the steel belt inwards.

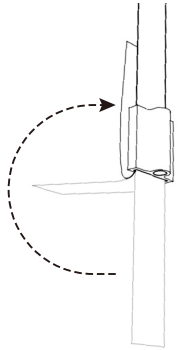

The steel strip on the other side is bent and folded according to the same steps.



Remove the screws, springs and washers on one side.



Pass the screw through the buckle.

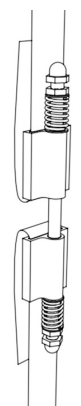

Put the gasket, spring, gasket in turn, and tighten the screws.

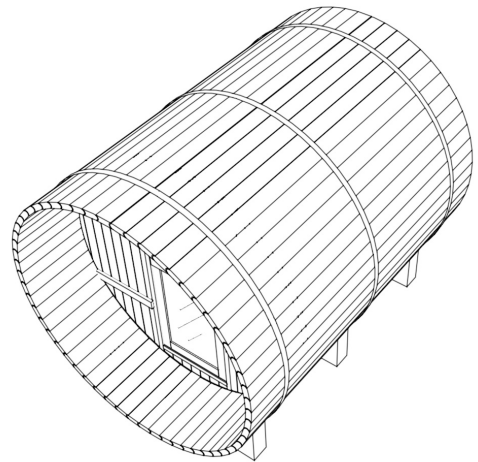

# 4. Accessories installation

First place the inside and outside ( series with porch ) floors, then install other accessories such as stools.

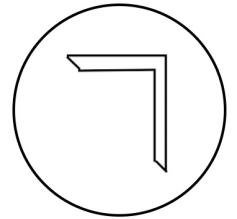

## Required accessories:

- |                                |  |                              |
|--------------------------------|--|------------------------------|
| 1. Bench                       | 2. Bevel support                         | 3. Floor                     |
| Inside bench                   | 2-4 pcs for inside bench                 | Inside floor                 |
| Outside bench ( Series porch ) | 2 pcs for outside bench ( Series porch ) | Outside floor (Series porch) |

<p>①</p> <p>Inside floor</p> <p>Outside floor (series porch)</p>	<p>②</p> <p>Inside floor</p> <p>Outside floor (series porch)</p> <p>Bracket of outside bench (series porch)</p>
<p>③</p> <p>Bench inside</p> <p>For series with porch</p> <p>Secure the bench to the support with screws.</p>	<p>④</p> <p>Secure the supports to the staves with screws.</p>
<p>⑤</p> <p>Outside bench (series porch)</p> <p>Secure the bench to the support with screws.</p>	<p>⑥</p> <p>Outside bench (series porch)</p> <p>Secure the supports to the staves with screws.</p>

# 5.Sauna heater fence and lamp assembly (Lamp is optional)

## ① Sauna heater fence

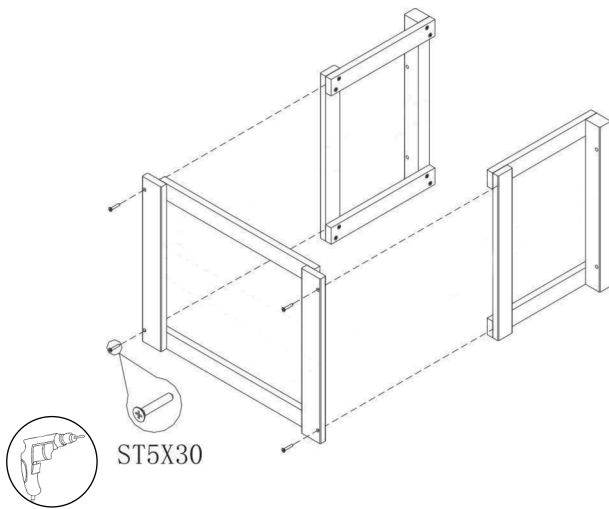

## ②

Sauna heater

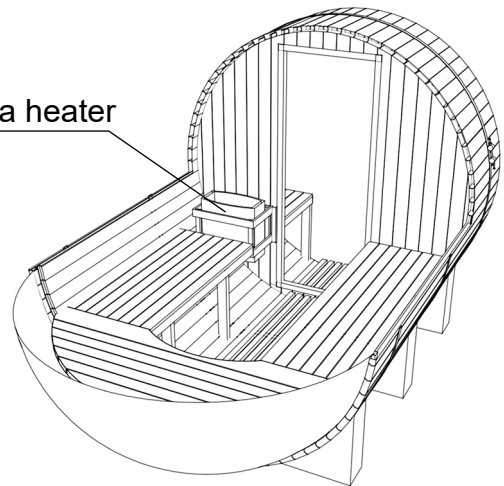

! Please refer to heater instructions for installation the heater.

## ③

Sauna heater fence

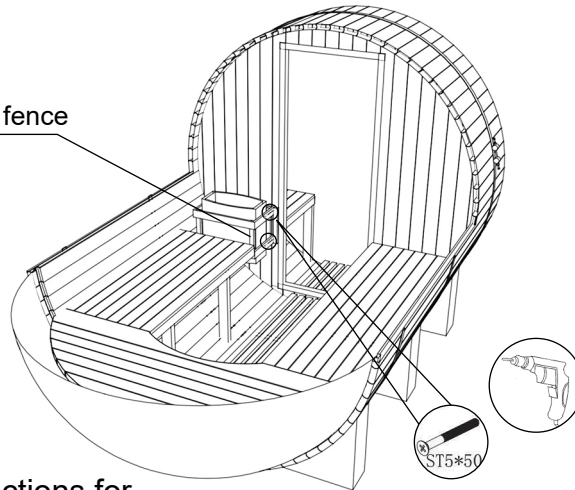

! Please refer to heater instructions for installation the heater fence.

## ④ Sauna lamp assembly(Lamp is optional)

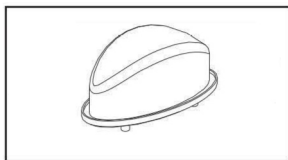

4-1: Accessories of lamp

4-2:Lamp assembly

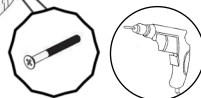
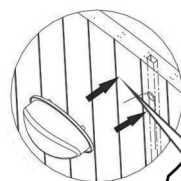

Sauna Light

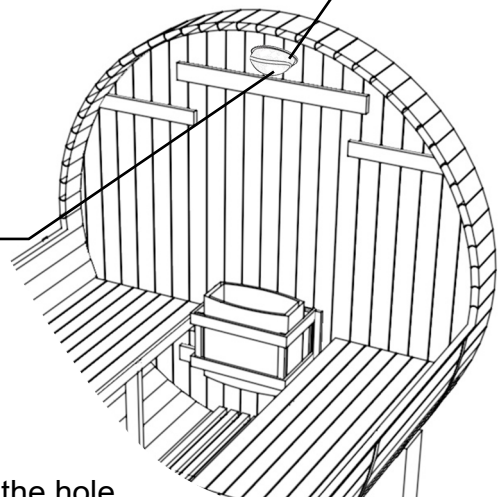

Note: Make hole in the wall by yourself,then wire out from the hole.

## 6. External waterproofing installation

- ① Install the water retaining strips on both sides (the height is level with the door handle).

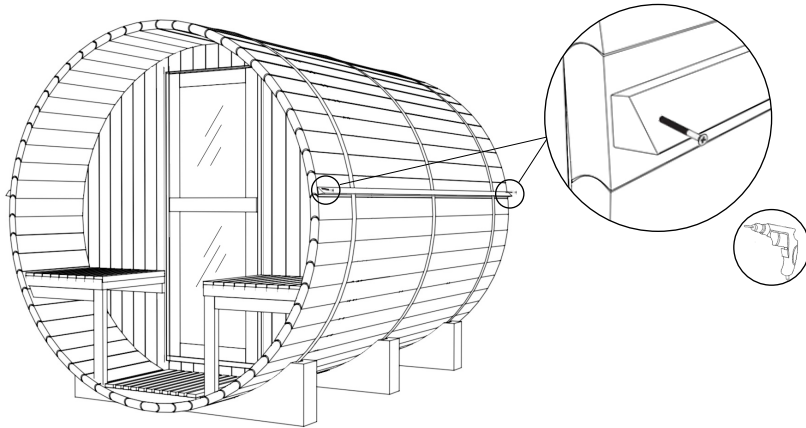

②

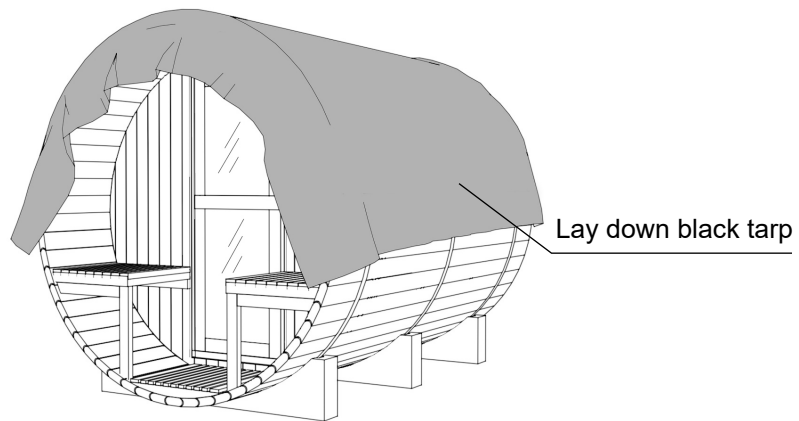

③

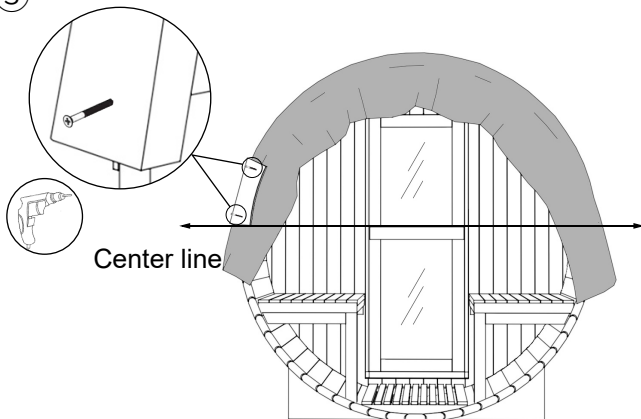

- ④ Install the front and rear decorative panels of the barrel sauna (the height is flush with the water retaining strip).

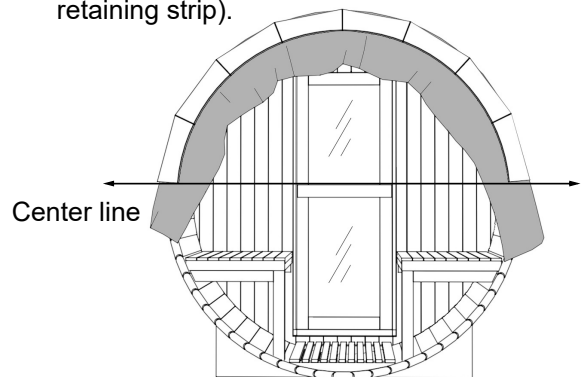

⑤

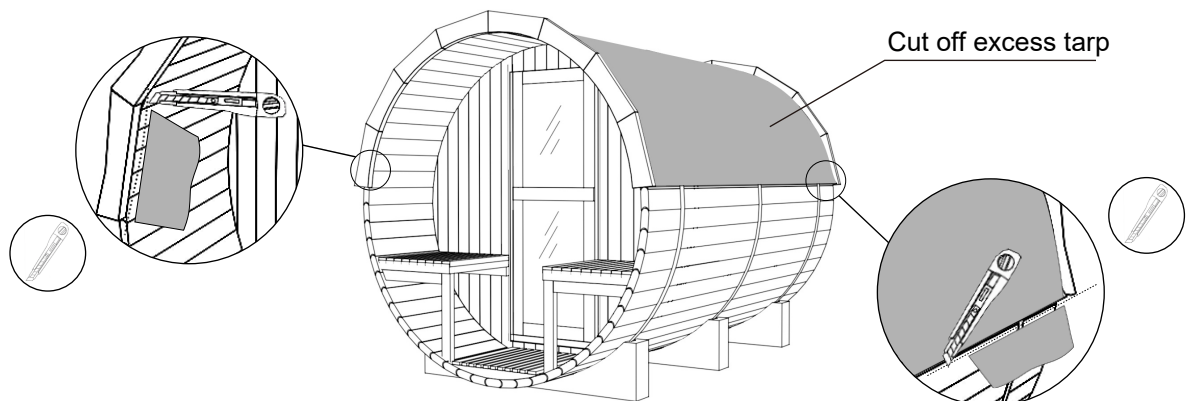

# (1) Asphalt shingles installation

- ① Suggestion: Use a nail gun to fix the three places in the middle of the head and tail of each piece.

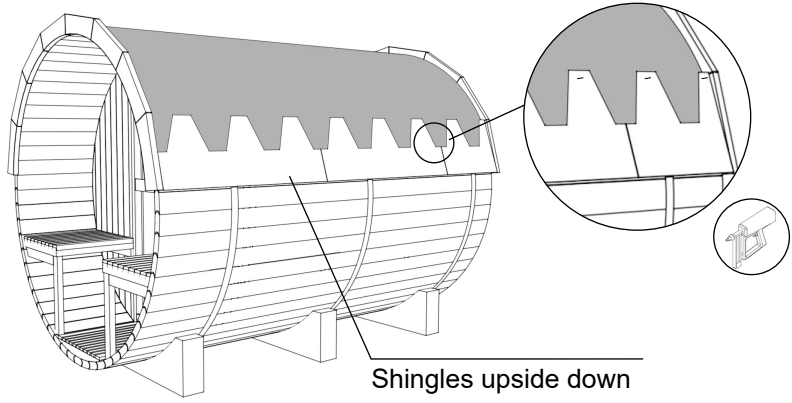

- ②

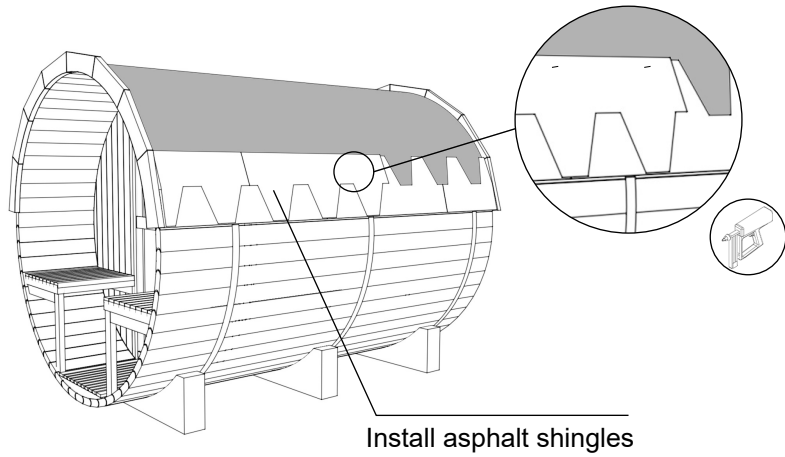

- ③ Cut off excess asphalt shingles.

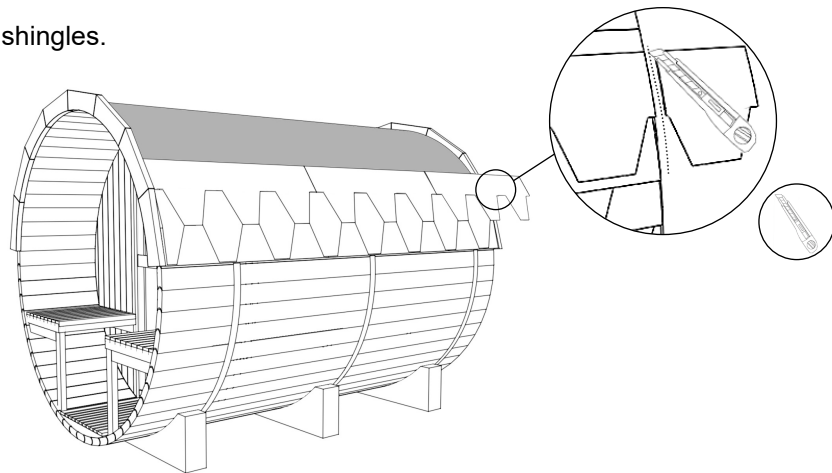

- ④

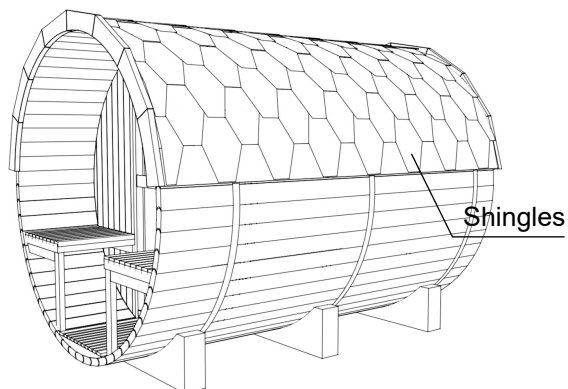

## (2) Wood shingles installtion

- ① From bottom to top, secure the side flashings with a nail gun.

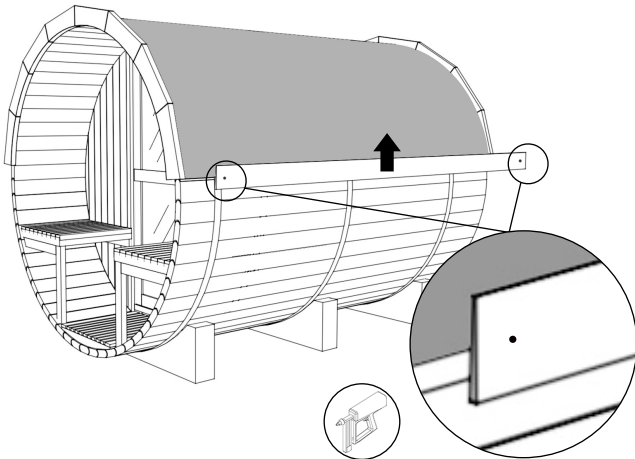

②

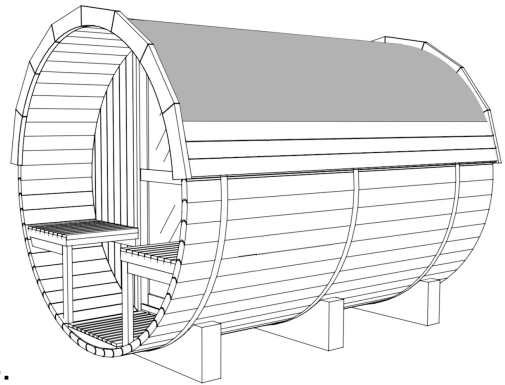

**NOTE:**  
The thick side of the flashing is placed underneath.

③

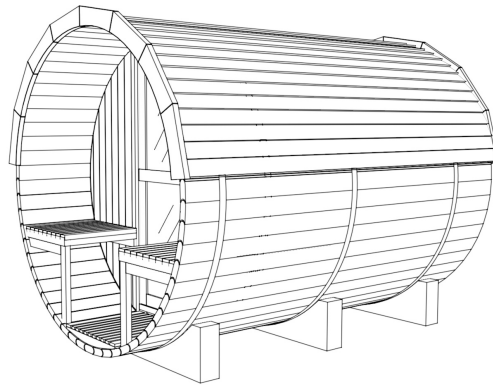

## 7.Filled with waterproof glue

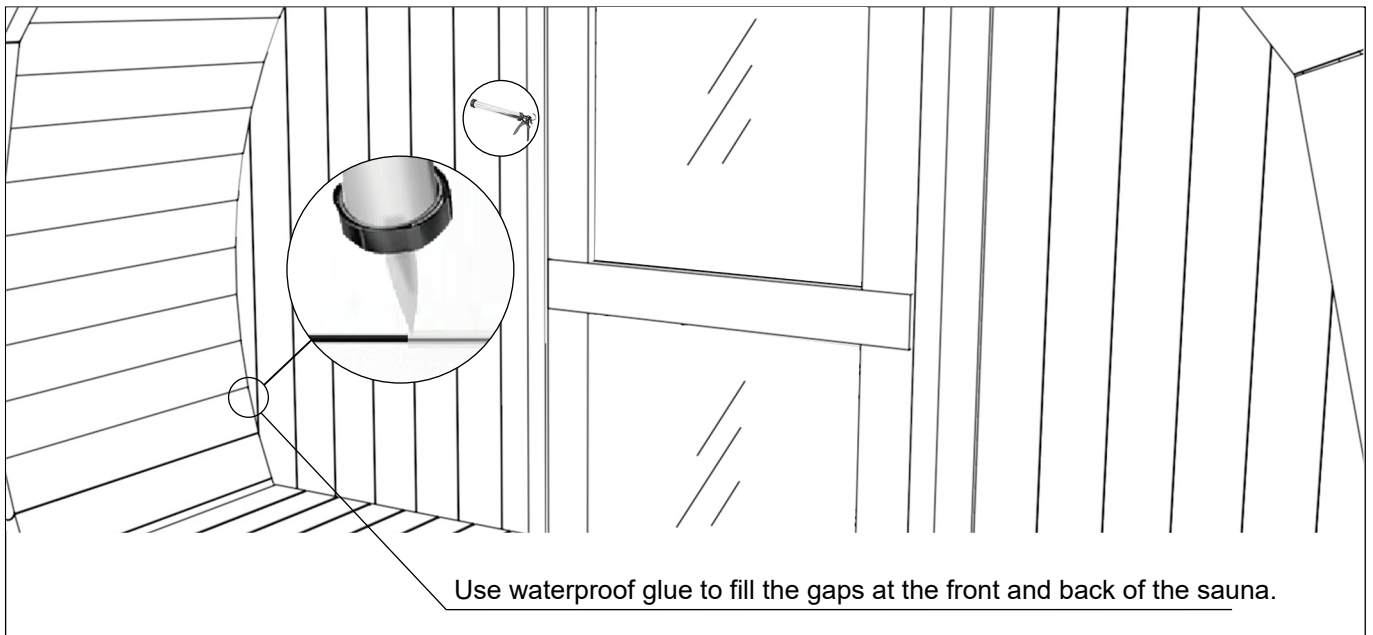

Use waterproof glue to fill the gaps at the front and back of the sauna.

## **8. Instructions:**

### **Maintenance instructions**

(1 ) Turn on sauna heater, setting desired temperature, normally 60°C-80°C (in the area between bench surface and your head). Start with low temperature and increase it according to endurance of your body when you are in a sauna for the firsttime.

(2) Before the sauna, take off clothes, glasses, jewelries, cell phones and other belongings, and then take a simple shower or spa.

(3) The average sauna period for each time is around 5-15 minutes.

(4) After a sauna, you can take a bath in a swimming pool or take a shower to cool your body for 10-20 minutes.

(5) After re-entering the sauna, you may find there are drops formed by vapor on sauna stones. If water drops to the ground, it means you are overusing the sauna.

(6) At least rest for 20 minutes after the last time in sauna. First take a shower with soap and warm water, then with cool water to close skin pores. Put on clothes after your body temperature completely lowers. ( children must be companied by parents)

### **Suggestions:**

(1 ) Paint the surface of sauna annually. You can choose the wood wax coating service provided by our company when purchasing the product.

(2) Put a carpet before the door to keep the floor clean.

(3) Brush obstinate stains on the sauna with sandpaper for daily maintenance.

(4) Replace sauna stones after over 500 hours in normal use.