

ASSEMBLY INSTRUCTIONS













ASSEMBLY TIPS:

1. Remove hardware from box and sort by size.
2. Please check to see that all hardware and parts are present prior to start of assembly.
3. Please follow attached instructions in the same sequence as numbered to assure fast & easy assembly.









Warning I

1. Don't attempt to repair or modify parts that are broken or defective. Please contact the store immediately.
2. This product is for home use only and not intended for commercial establishment.

PARTS IDENTIFICATION:

A		TABLE TOP	1pc
B		TABLE FRAME	2pcs
C		TABLE LEG	2pcs
D		BACK FRAME	4pcs
E1		LEFT LEG	4pcs
E2		RIGHT LEG	4pcs
F		BAR	4pcs
G		BOTTOM CROSS BAR	4pcs
H		TOP CROSS BAR	4pcs
I		SEAT CUSHION	4pcs

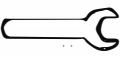
Z HARDWARE PACKAGE:

NO	DESCRIPTION	FIGURE	QTY
1	SHORT WOOD SCREW		4pcs
2	LARGE WOOD SCREW		16pcs
3	SHORT BOLT 1/4" x 1/2"		24pcs
4	EXTRA LARGE BOLT		16pcs
5	MEDIUM BOLT 1/4" x 3/8"		4pcs
6	LARGE BOLT		8pcs
7	HEX NUT		12pcs
8	WRENCH		1pc
9	ALLEN WRENCH		1pc

STEP 1

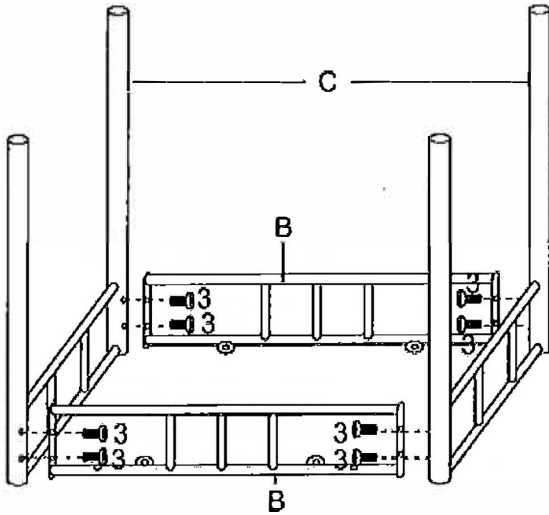

1. As shown in figure, use BOLT 3 to fix table frame and table legs together.

STEP 2

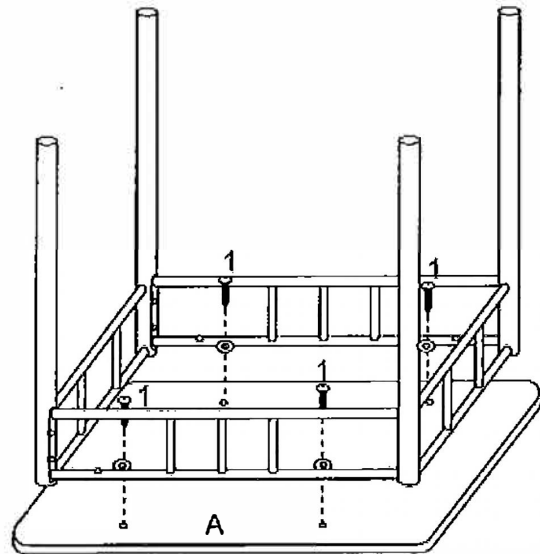

2. As shown in figure, assembling table top and table frame by SCREW 1.

STEP 3

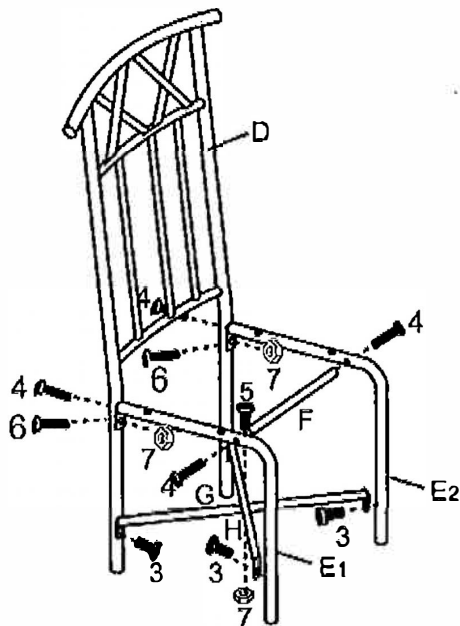

3. Attach left and right legs (E1 & E2) to the back (D) with bolts (4 & 6 & 7). Only hand tighten bolts. Attach bar (F) to legs with bolt (4). Attach cross bars (G & H) to the legs using bolt (3). Tighten all bolts with wrench.

STEP 4

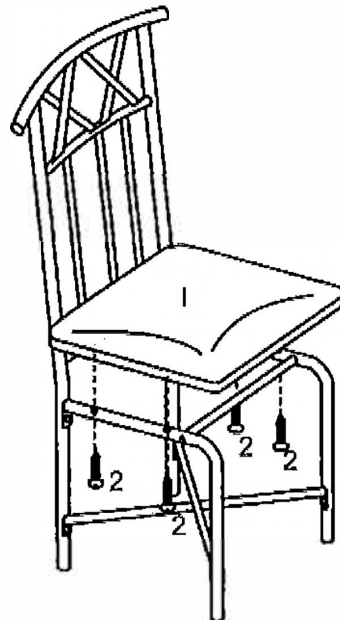

4. As shown in figure, put on cushion and assembling by SCREW 2...