

L-SHAPED DESK WITH FILE CABINET

ASSEMBLY INSTRUCTION

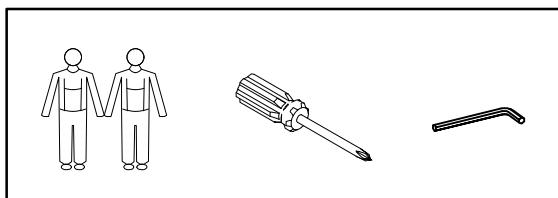
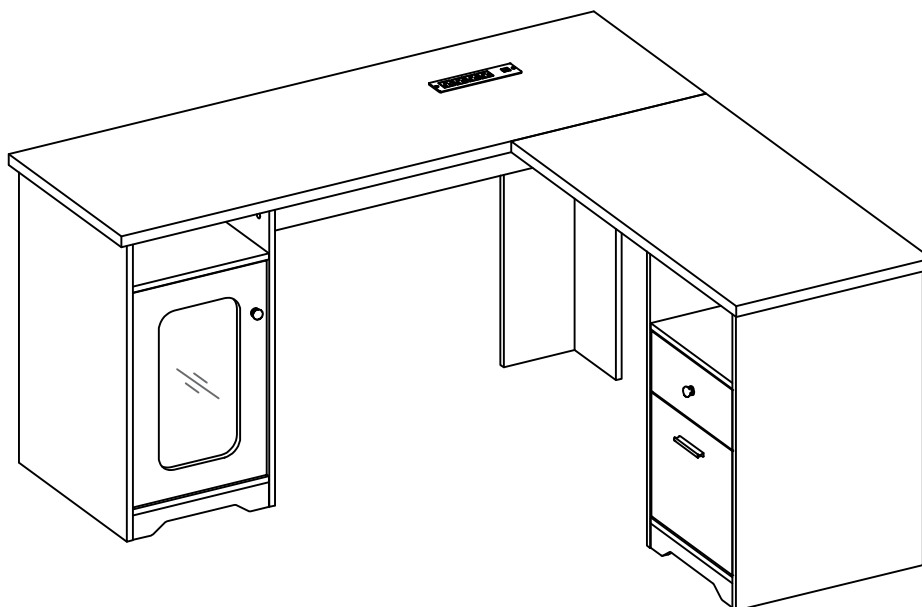

CAUTION

Put the screws in loosely until all pieces are together and then tighten them all.
It will save your time if you make a mistake while installing.



There are two packages for this rack, you may not receive them at the same time, please wait a few days if you only get one package.

Dear Customers,

Thank you for purchasing our products.

As a reliable seller, we have been pursuing to provide customers with 100% satisfied products and services, so we hope that you will enjoy this shopping experience.

If you find any damage, missing parts, or dissatisfaction after receiving the product, please contact us freely at the first time. We will provide you with a 100% satisfactory solution.

Thanks again for your order. Please feel free to case of any problem regarding assembling or the product itself. We will do everything we can to resolve it.



Please follow the instruction manuals and use a pad to protect the product during your assembly.

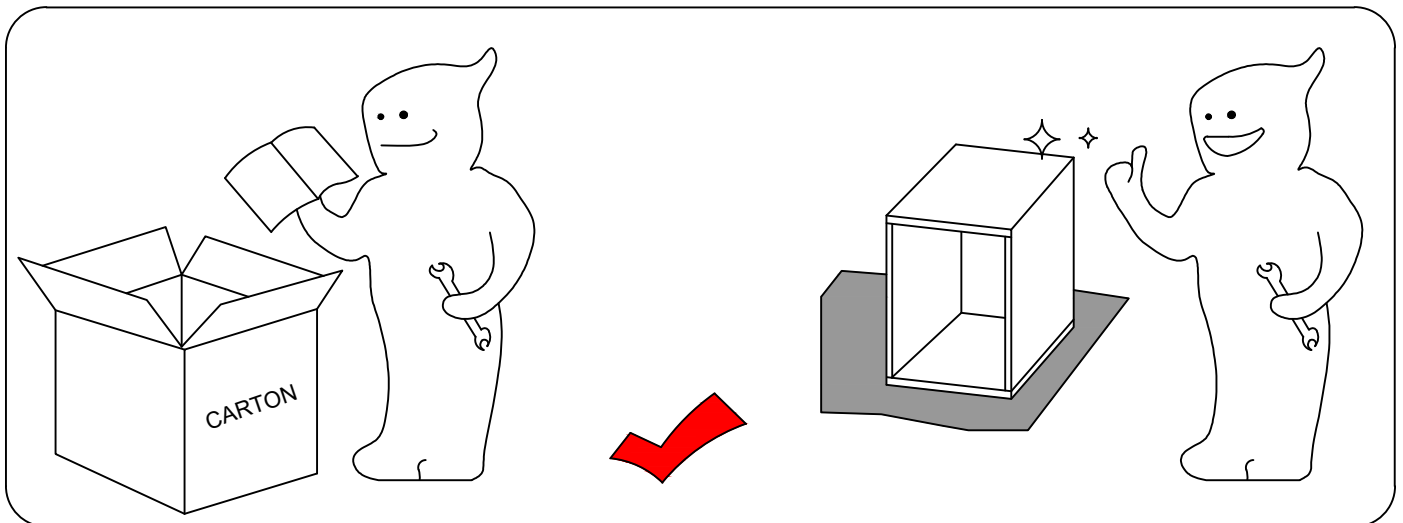
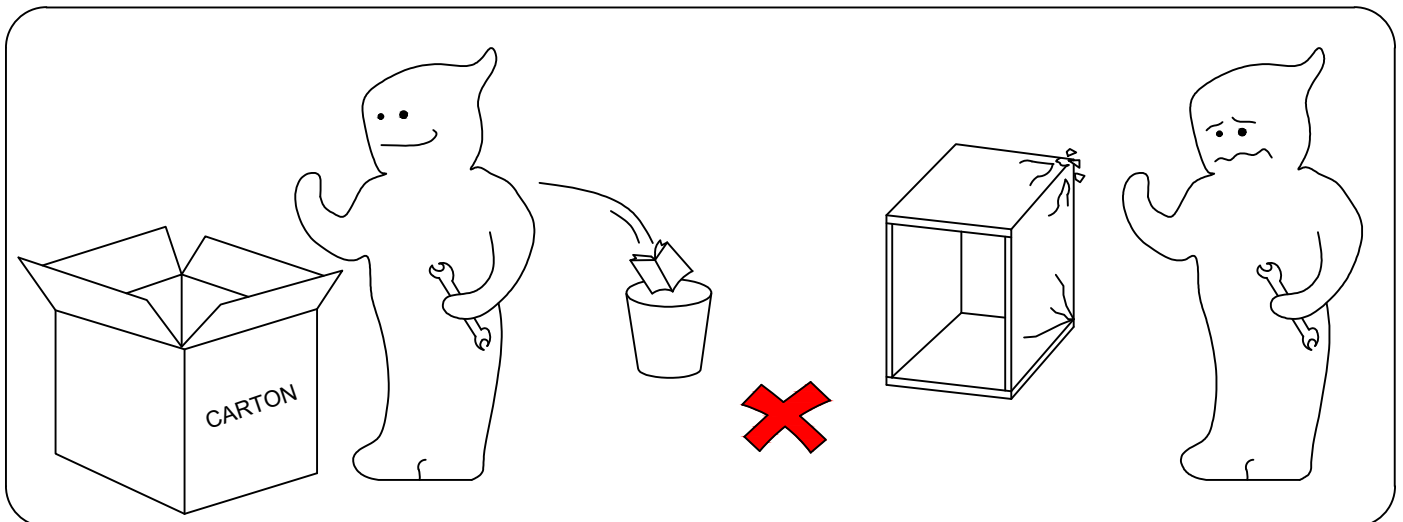

Using Camlocks

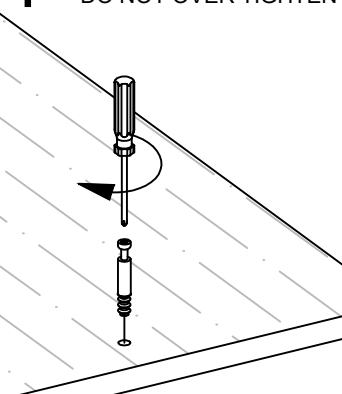
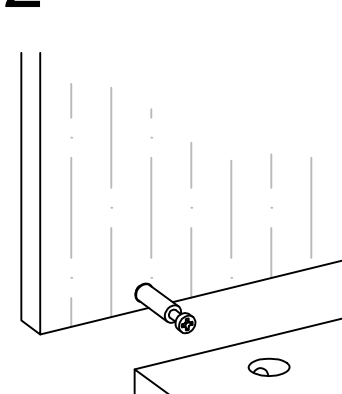
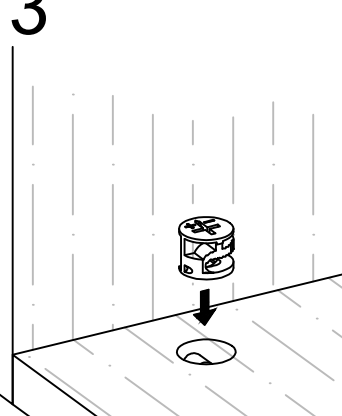
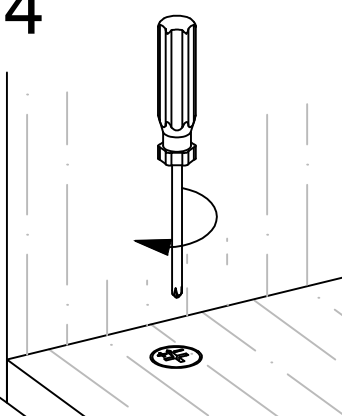
<p>Connect the male camlock as directed in the assembly instructions using a screwdriver.</p>	<p>1 DO NOT OVER TIGHTEN</p> 	<p>Push the male camlock into the entry hole.</p>	<p>2</p> 
<p>Insert the female camlock as shown in the instruction.</p> <p>Note: ensure that the arrow on the top of the camlock points toward the entry hole for the male camlock.</p>	<p>3</p> 	<p>Turn the female camlock clockwise with a screwdriver.</p> <p>You should feel a click when the camlock is locked in place.</p> <p>The joint is now secure.</p>	<p>4</p> 

HOW TO ADJUST THE EUROPEAN ADJUSTABLE HINGES ON DOOR

If the doors require adjustment, follow the below options as needed:

To adjust door up or down, loosen screws (a), adjust door and retighten screws.



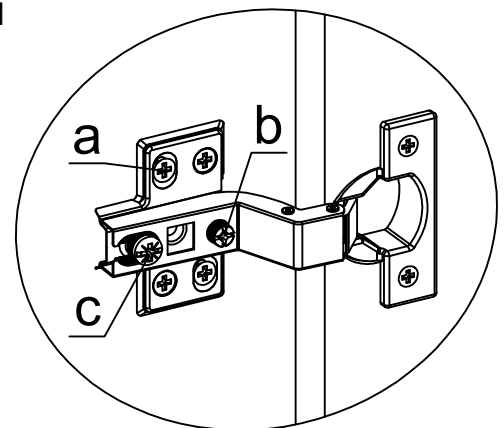

To adjust door left and right, turn screw (b) in or out.

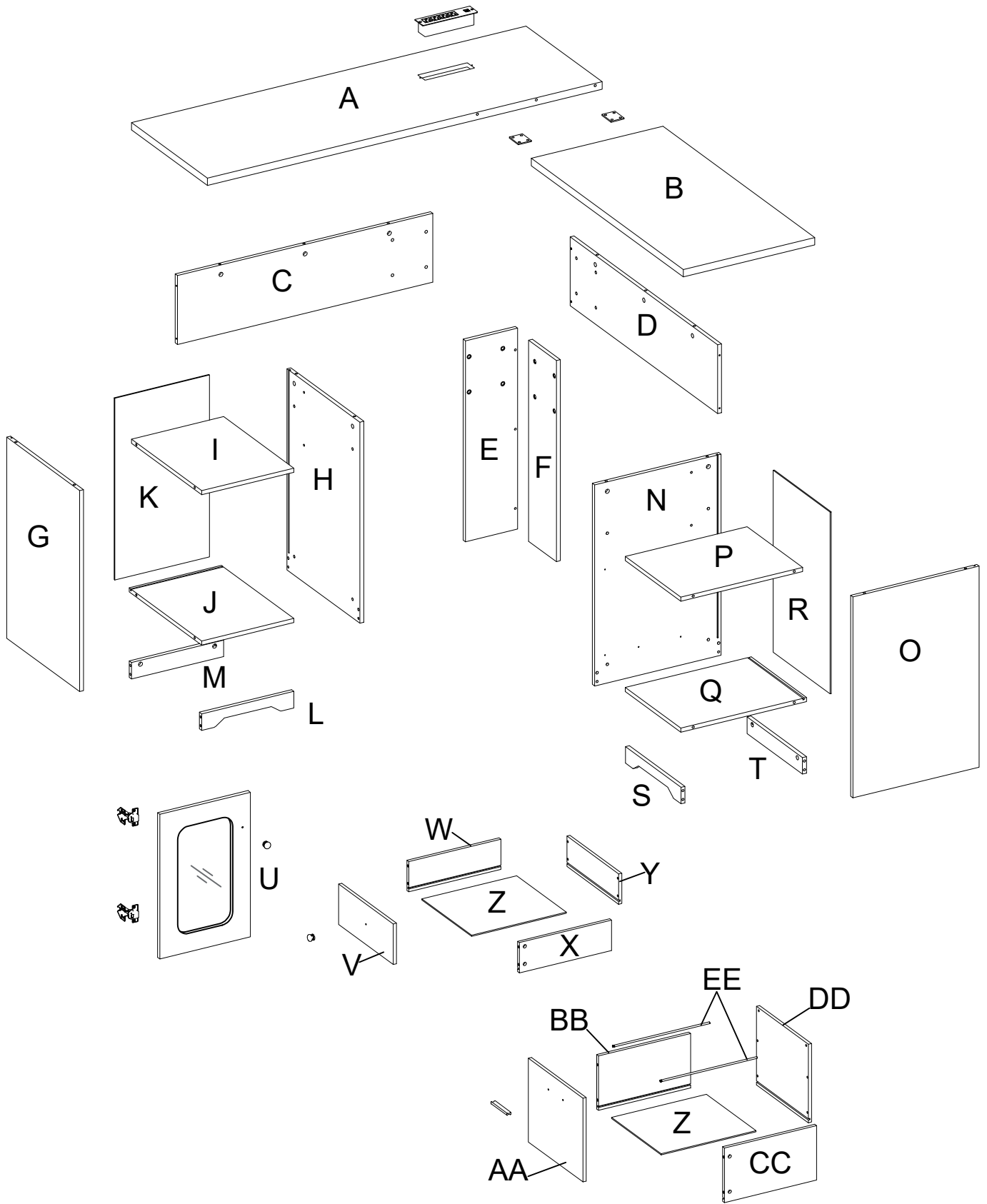
To adjust door in and out, loosen screw (c), adjust door and retighten screw.



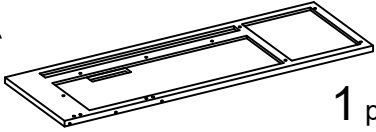
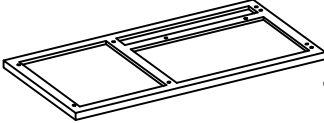
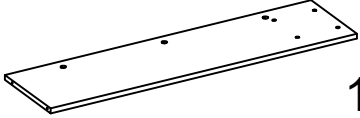
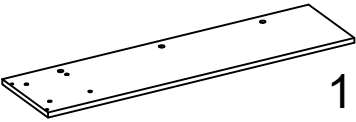
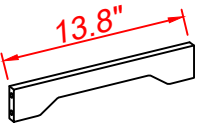
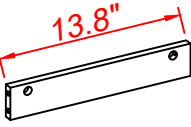
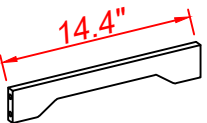
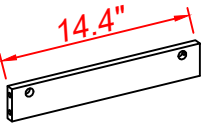
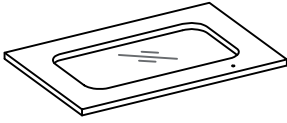
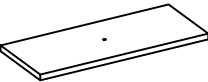
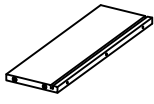
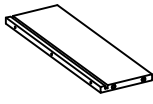

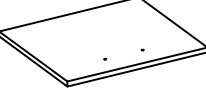
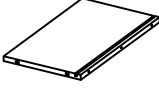
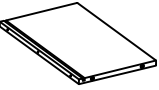
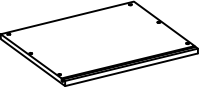

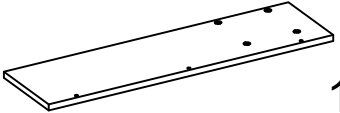
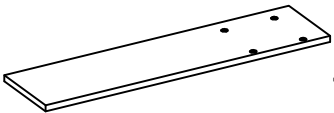
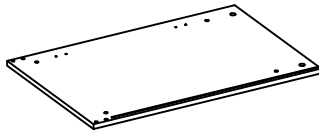
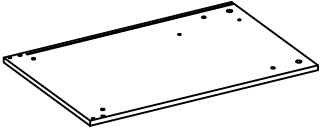
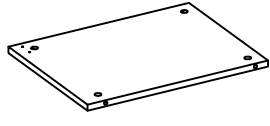
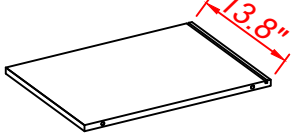
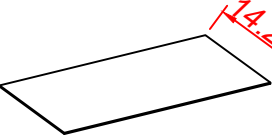
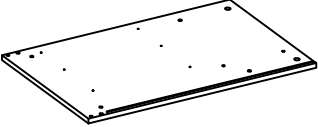
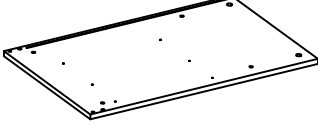
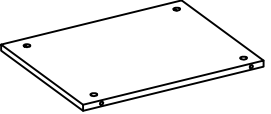
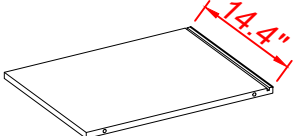
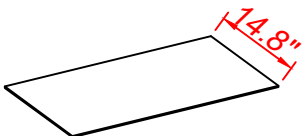
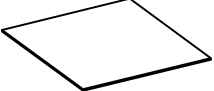



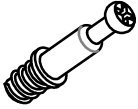

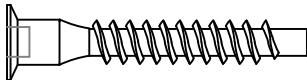
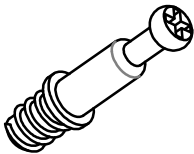

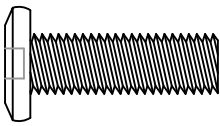

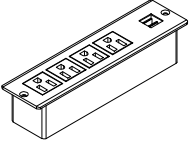

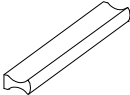
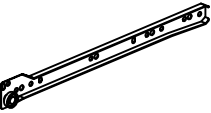
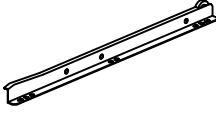
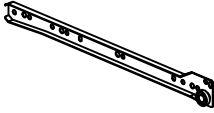
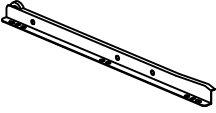
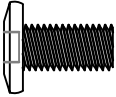
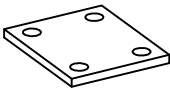
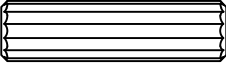
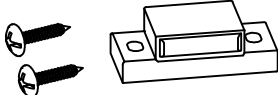
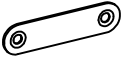

PART LIST A		
A  1 pc	B  1 pc	C  1 pc
D  1 pc	L  1 pc	M  1 pc
S  4 pcs	T  1 pc	U  1 pc
V  1 pc	W  1 pc	X  1 pc
Y  1 pc	AA  1 pc	BB  1 pc
CC  1 pc	DD  1 pc	EE  2 pcs
PART LIST B		
E  1 pc	F  1 pc	G  1 pc
H  1 pc	I  1 pc	J  1 pc
K  1 pc	N  1 pc	O  1 pc
P  1 pc	Q  1 pc	R  1 pc
Z  2 pcs		

HARDWARE LIST

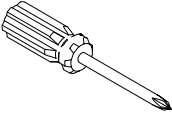
<p>①</p>  <p>M6x28 8 pcs</p>	<p>②</p>  <p>Ø12 8 pcs</p>	<p>③</p>  <p>M6x40 17 pcs</p>	<p>④</p>  <p>M6x40 38 pcs</p>
<p>⑤</p>  <p>Ø15 38 pcs</p>	<p>⑥</p>  <p>M8x25 8 pcs</p>	<p>⑦</p>  <p>M3x12 28 pcs</p>	<p>⑧</p>  <p>1 pc</p>
<p>⑨</p>  <p>M4x20 2 pcs</p>	<p>⑩</p>  <p>2 pcs</p>	<p>⑪</p>  <p>M4x16 2 pcs</p>	<p>⑫</p>  <p>1 pc</p>
<p>⑬</p>  <p>2 pcs</p>	<p>⑭</p>  <p>2 pcs</p>	<p>⑮</p>  <p>2 pcs</p>	<p>⑯</p>  <p>2 pcs</p>
<p>⑰</p>  <p>M6x12 8 pcs</p>	<p>⑱</p>  <p>60*50*4 2 pcs</p>	<p>⑲</p>  <p>Ø8x30 11 pcs</p>	<p>⑳</p>  <p>M3x16 1 pc</p>
<p>㉑</p>  <p>1 pc</p>	<p>㉒</p>  <p>M4x14 12 pcs</p>	<p>㉓</p>  <p>Ø35 2 pcs</p>	<p>㉔</p>  <p>M4 1 pc</p>
<p>㉕</p>  <p>1 pc</p>			

STEP 1

③  x4

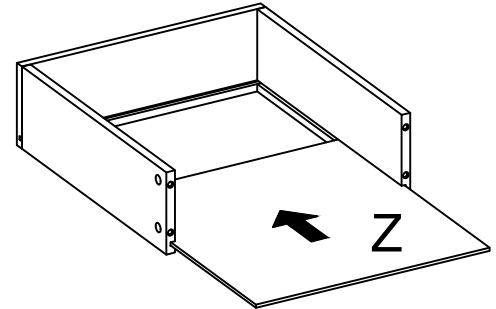
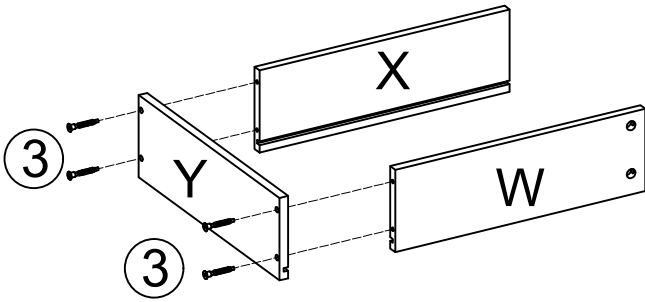

STEP 2

①  x4

②  x4

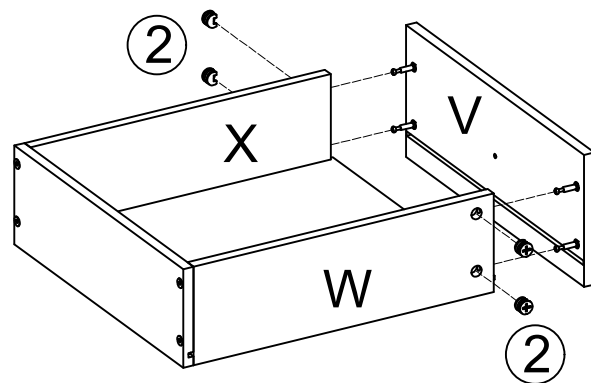
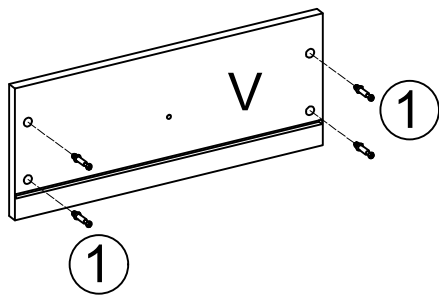

STEP 3

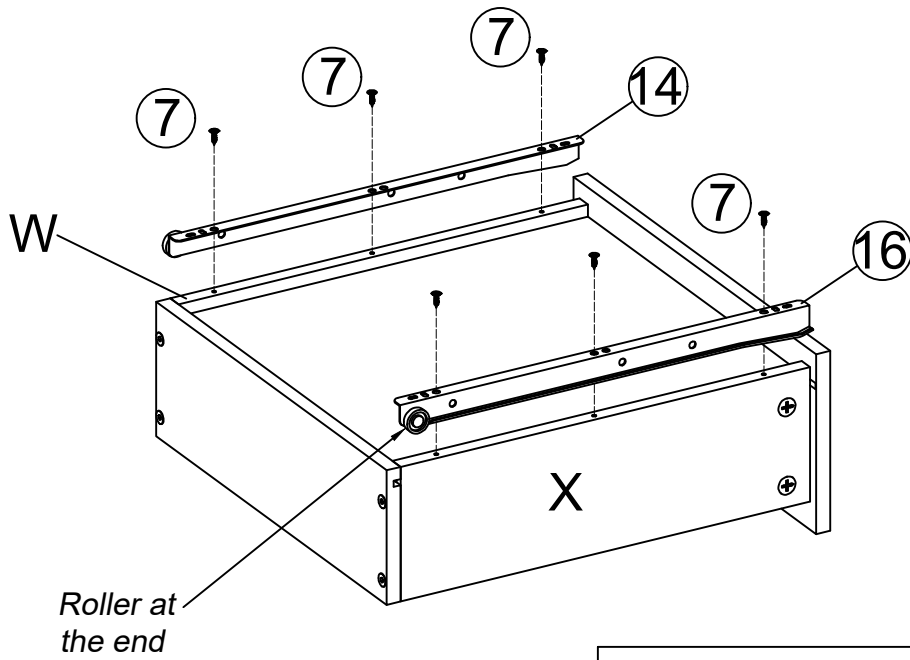

STEP 4

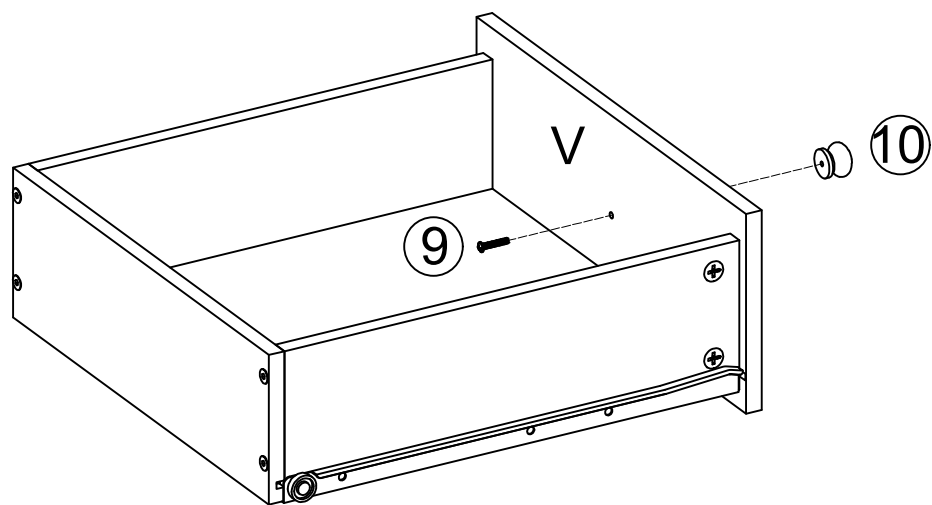

STEP 5

③  x4

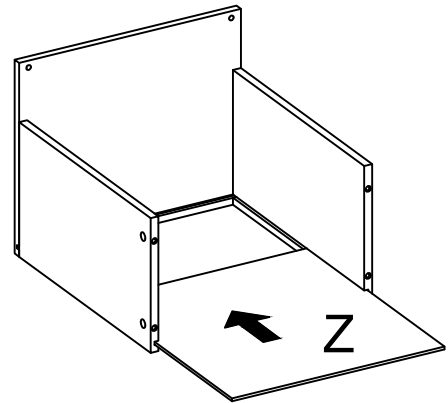
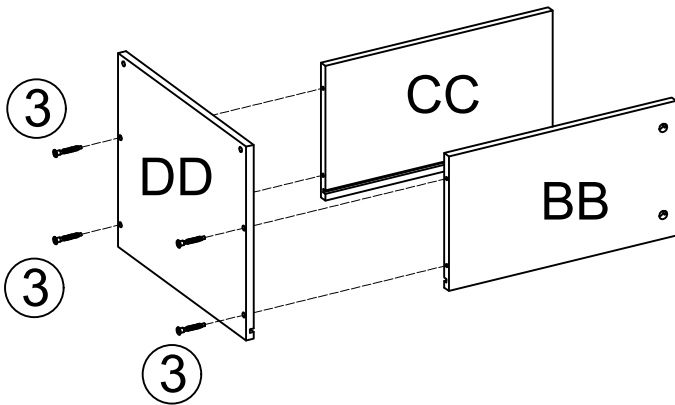

STEP 6

①  x4

②  x4

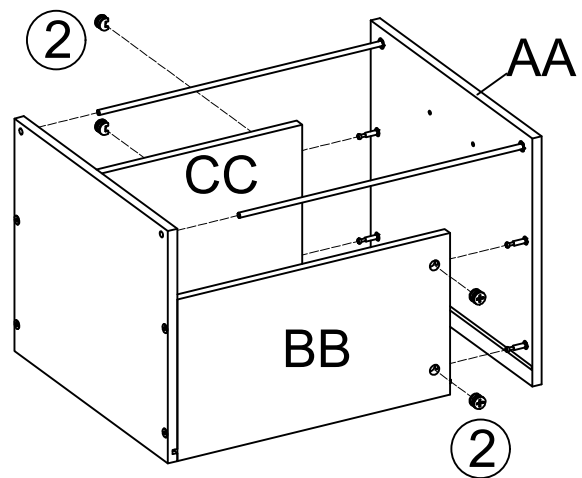
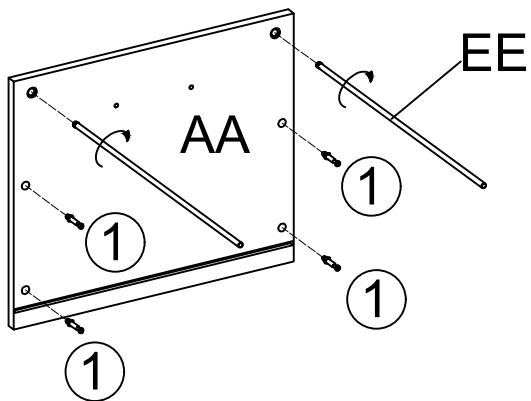

STEP 7

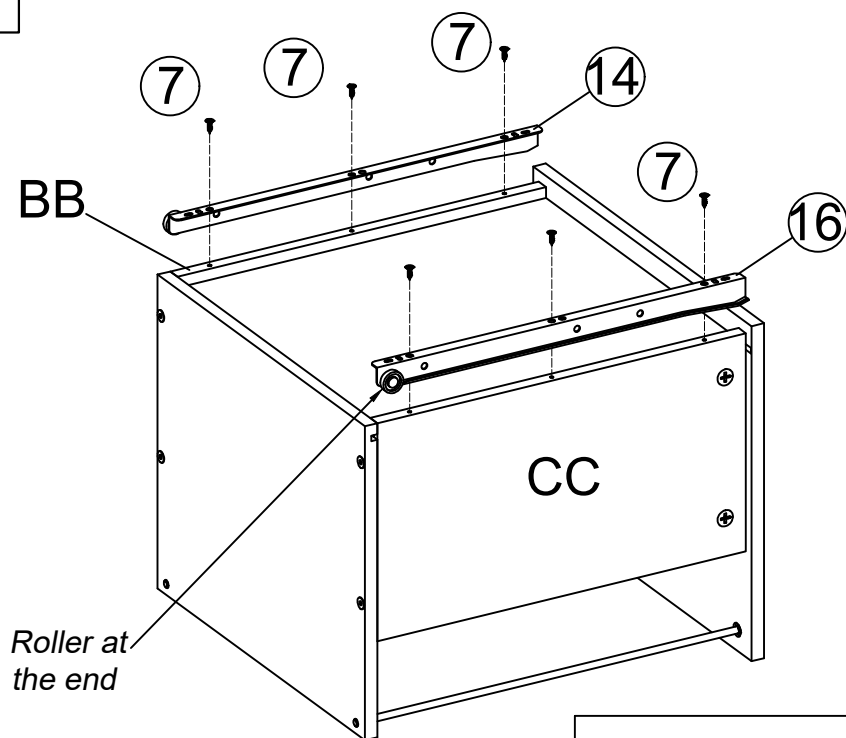

Roller at the end

- 7 x6
- 14 x1
- 16 x1

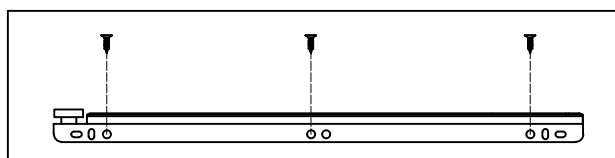

STEP 8

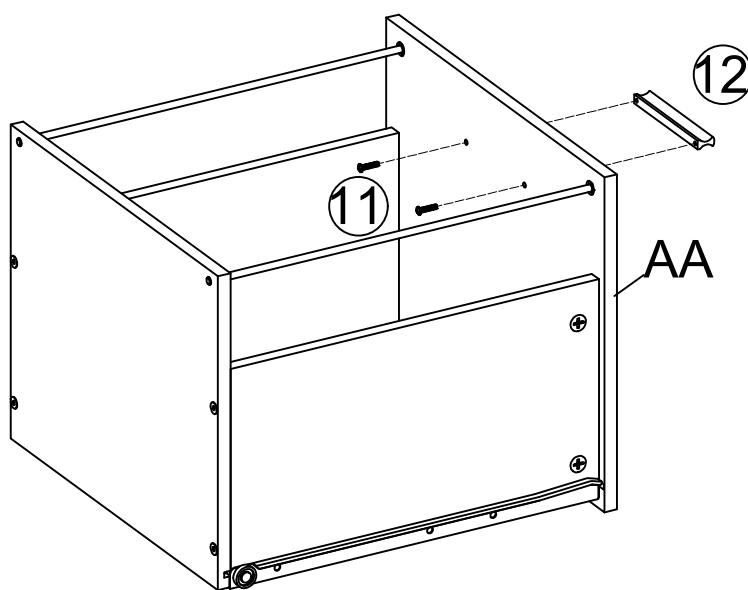

- 11 x2
- 12 x1

STEP 9

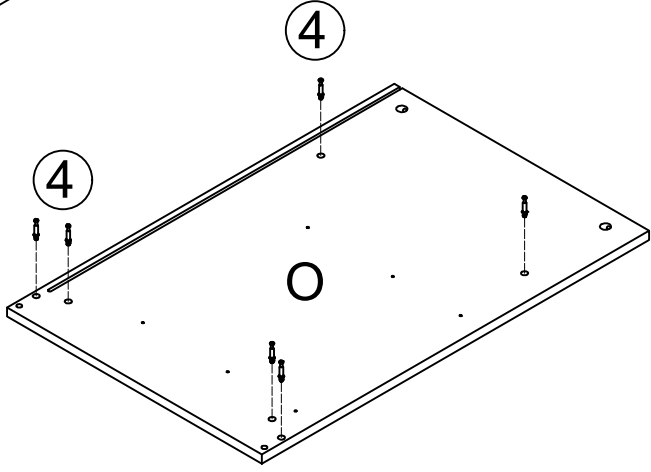
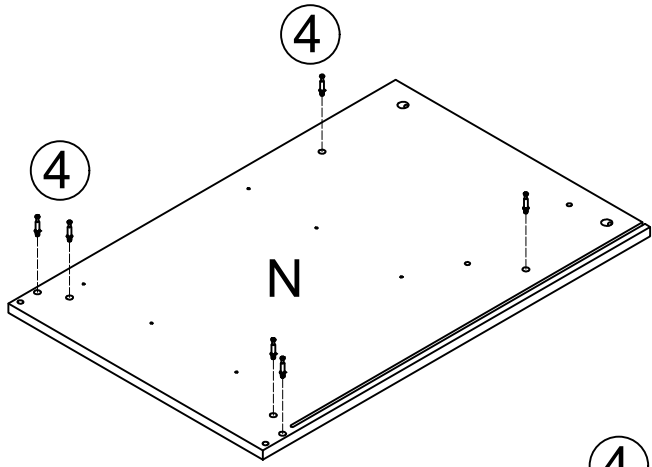

STEP 10

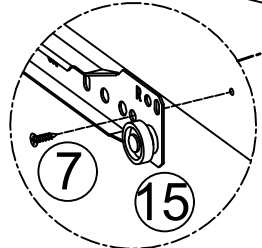
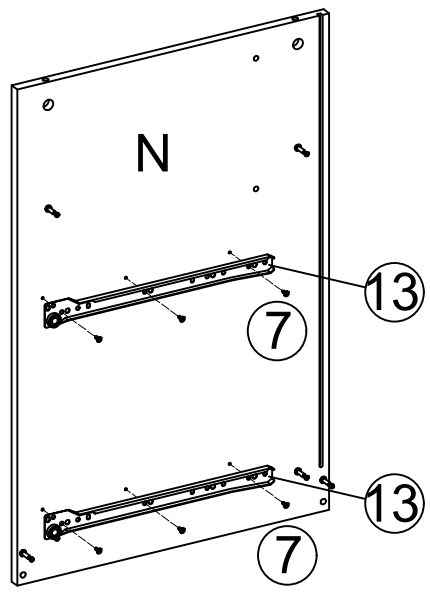
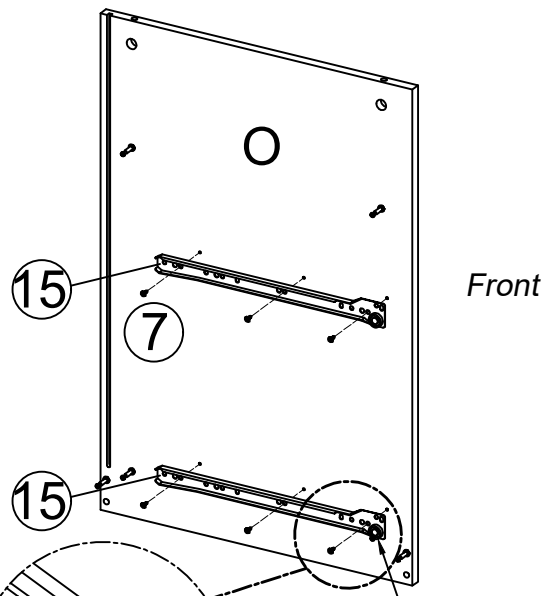

Roller is bottom

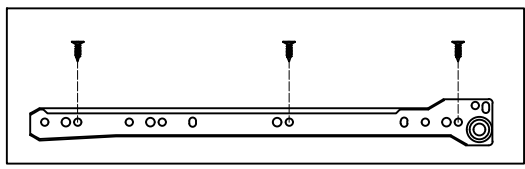

STEP 11

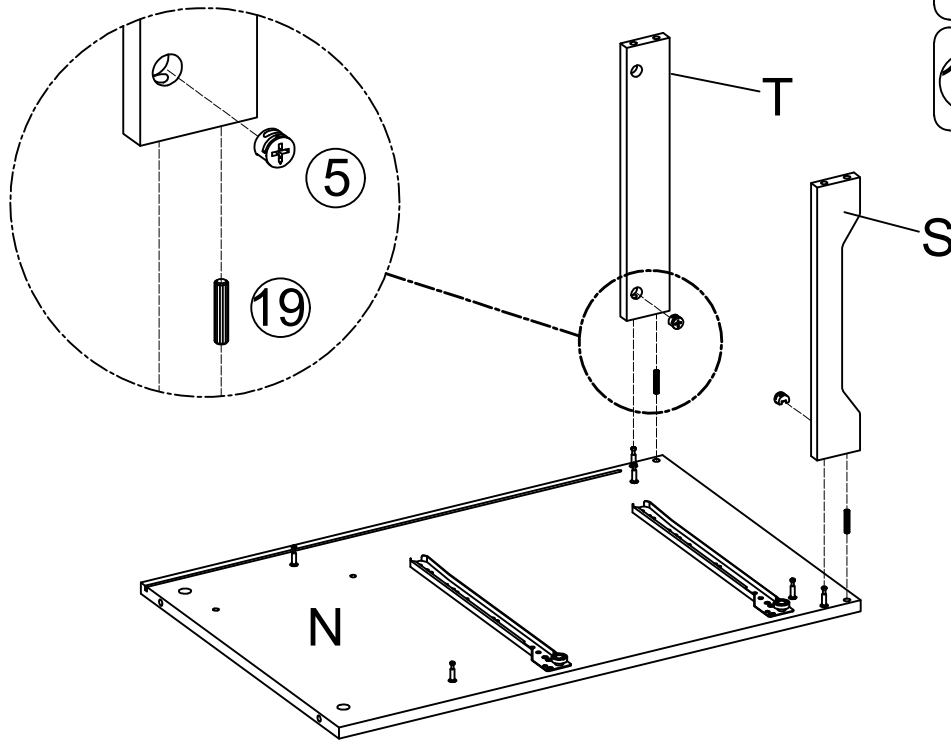

STEP 12

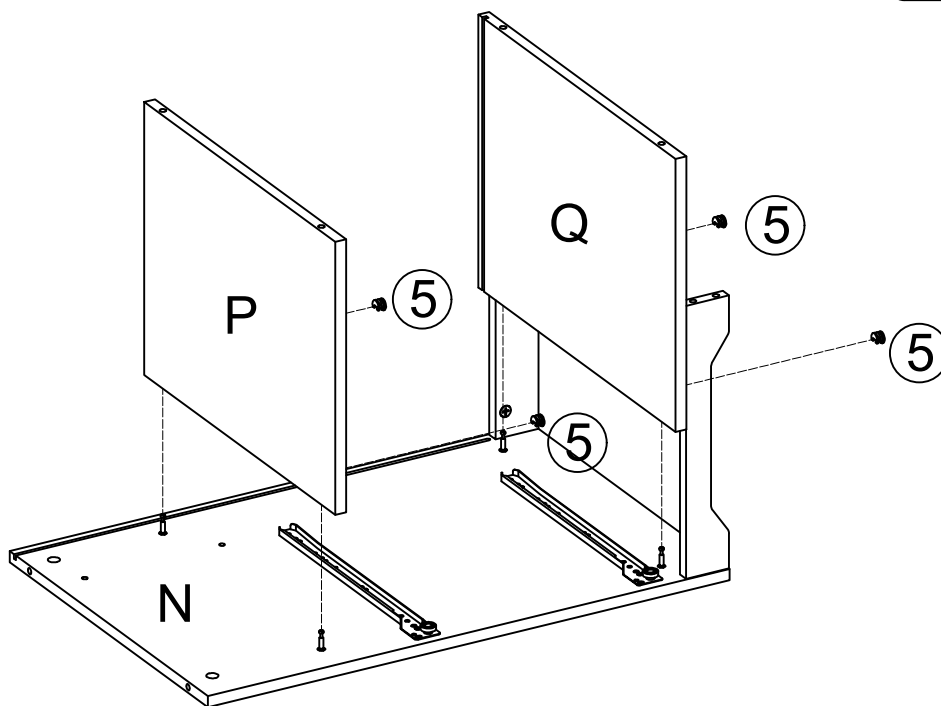

STEP 13

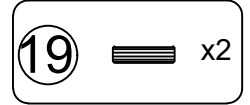
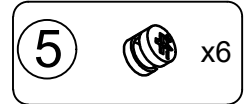
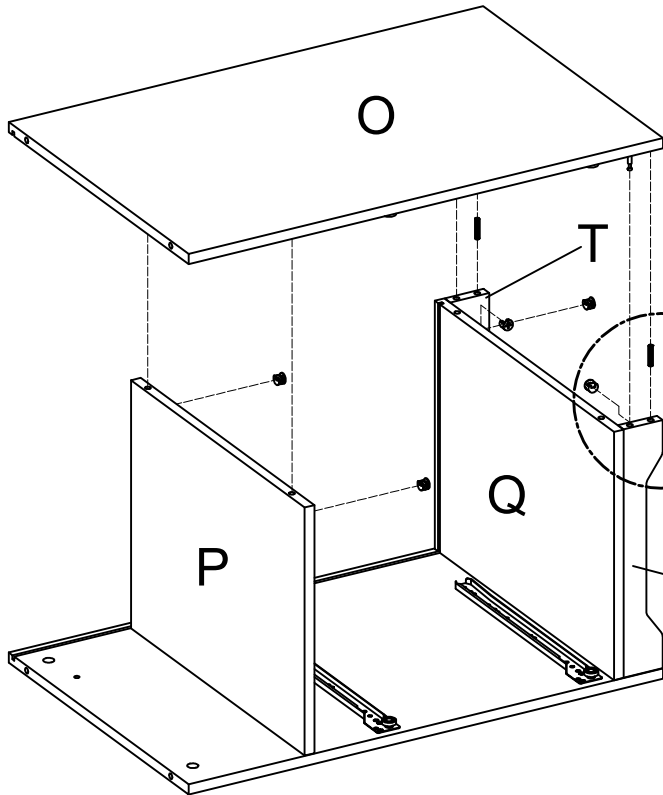

STEP 14

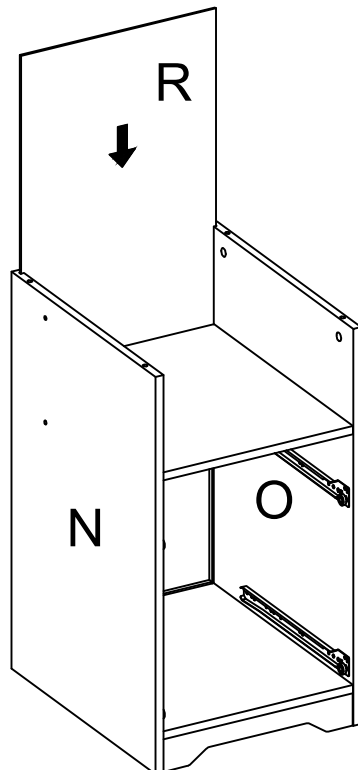

STEP 15

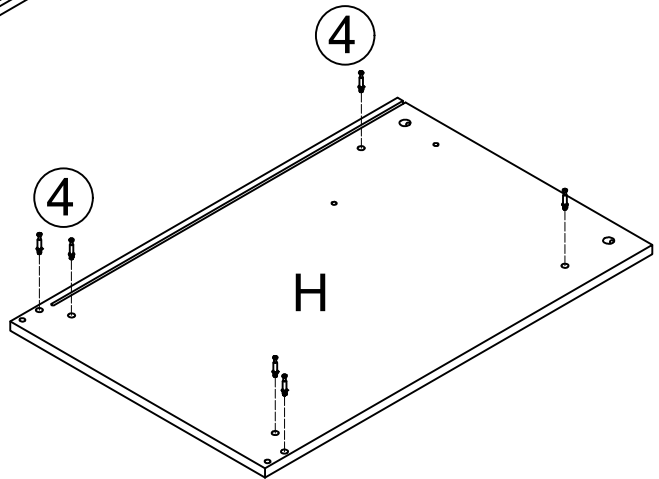
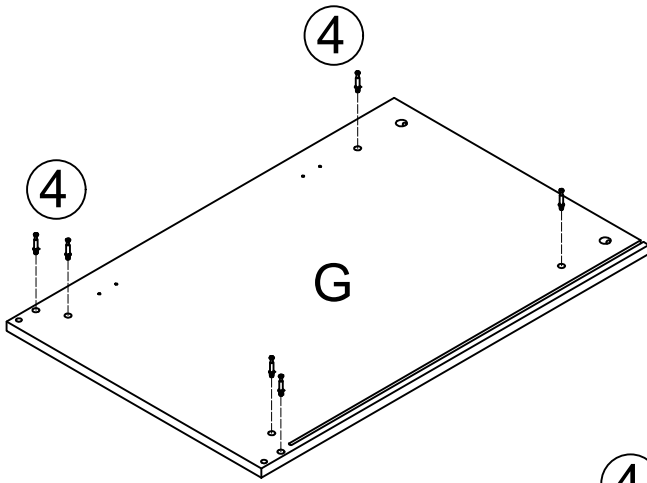
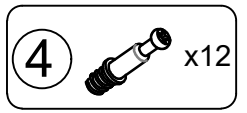

STEP 16

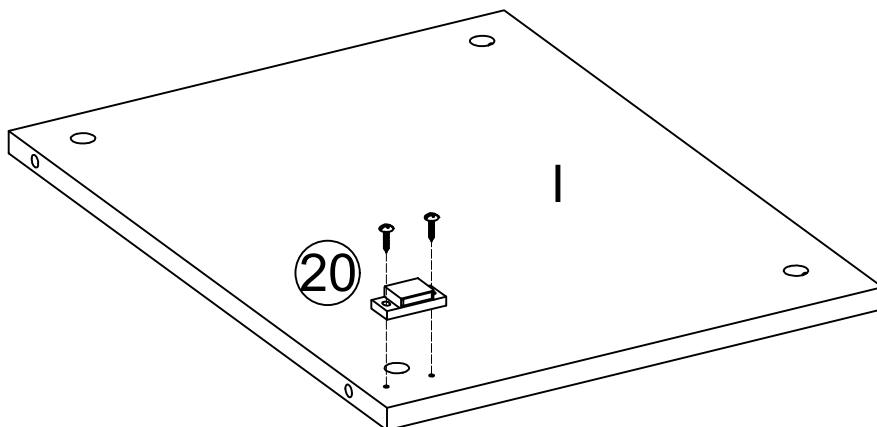
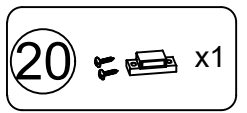

STEP 17

5  x2

19  x2

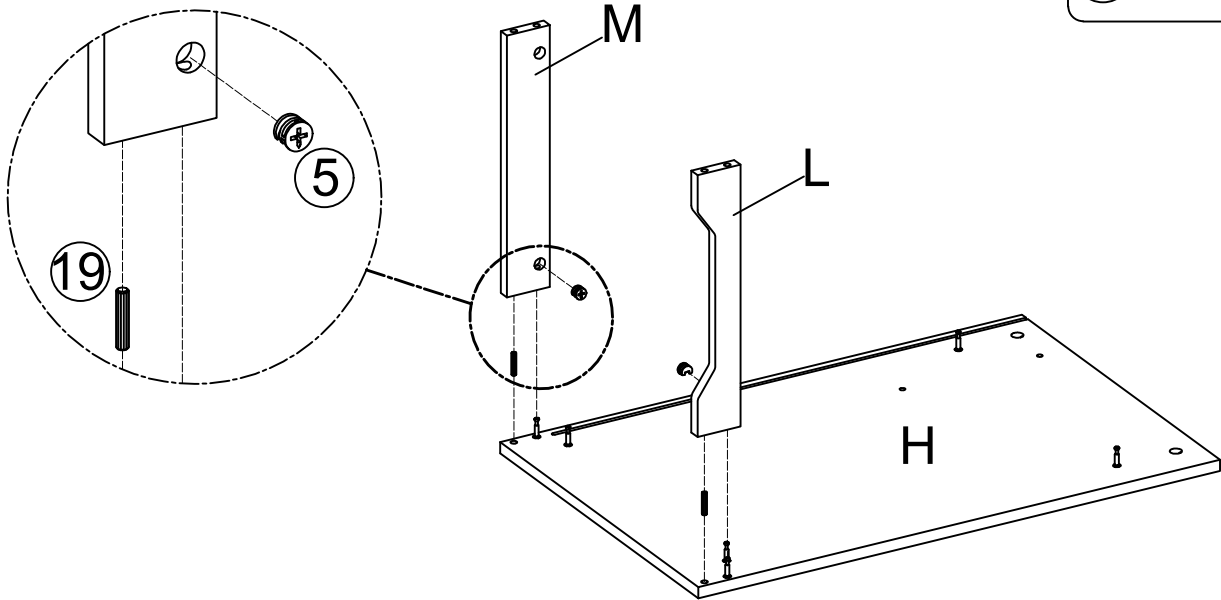

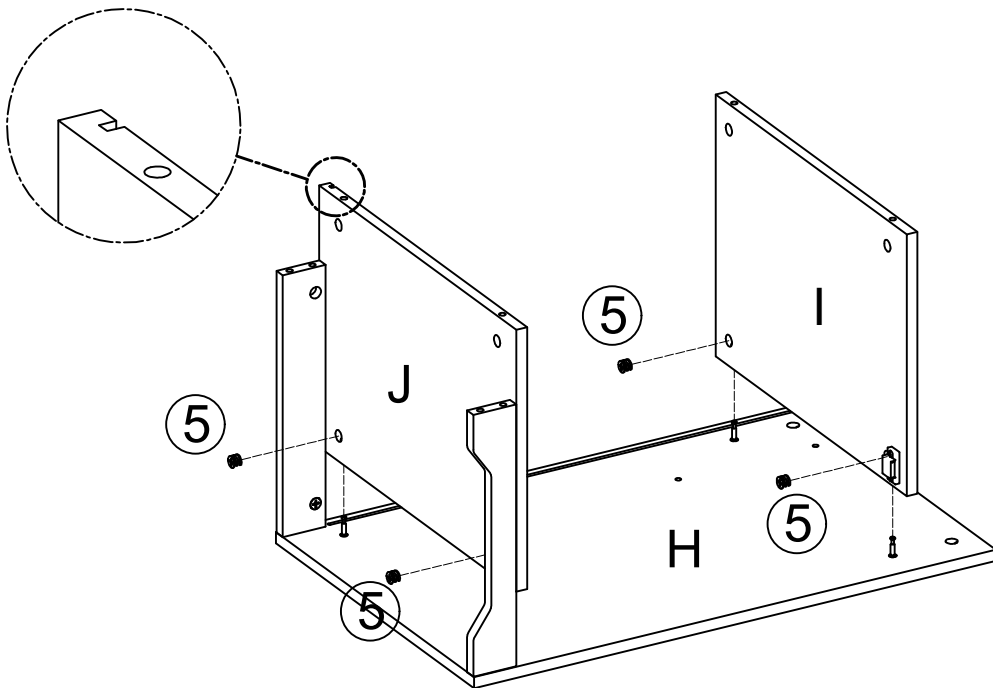

STEP 18

5  x4



STEP 19

- 5  x6
- 19  x2

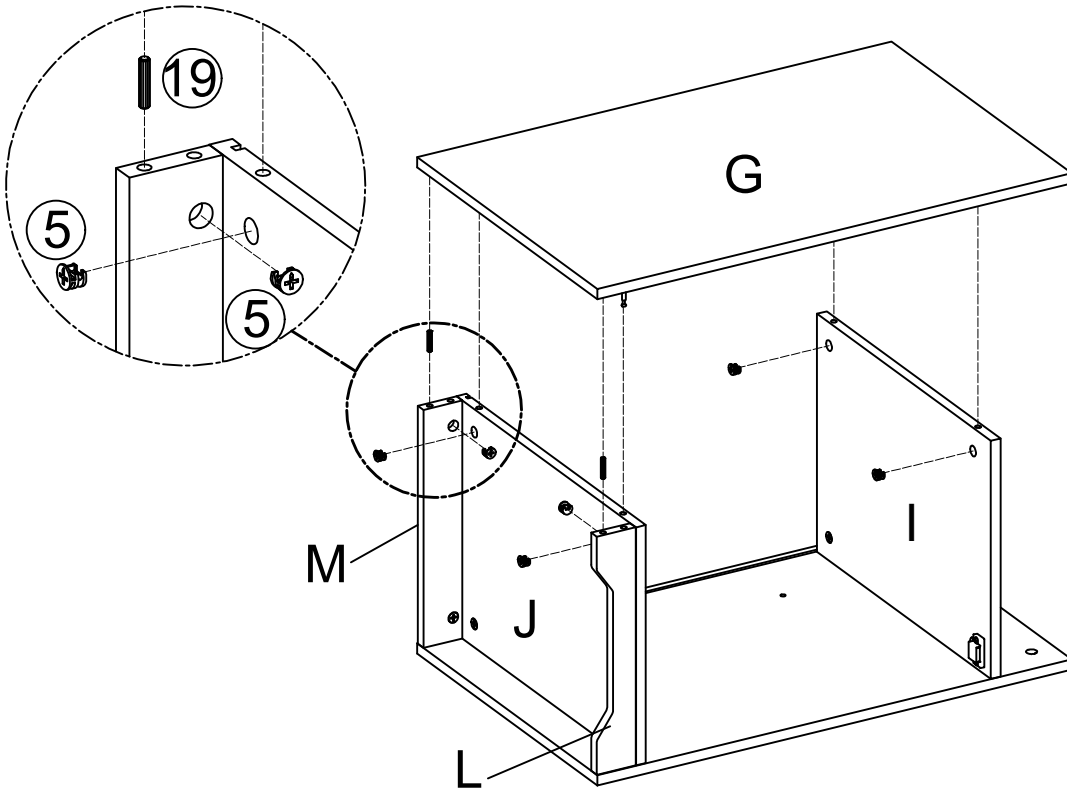

STEP 20

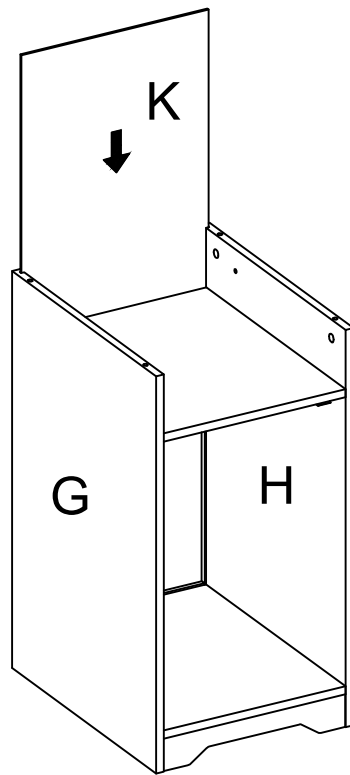

STEP 21

③  x3

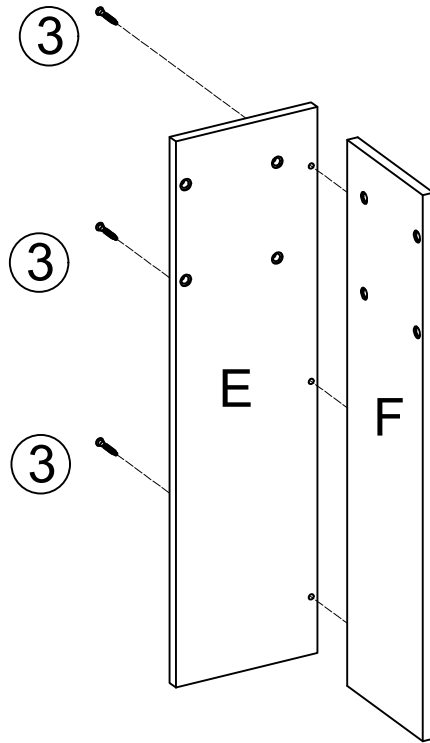

STEP 22

③  x2

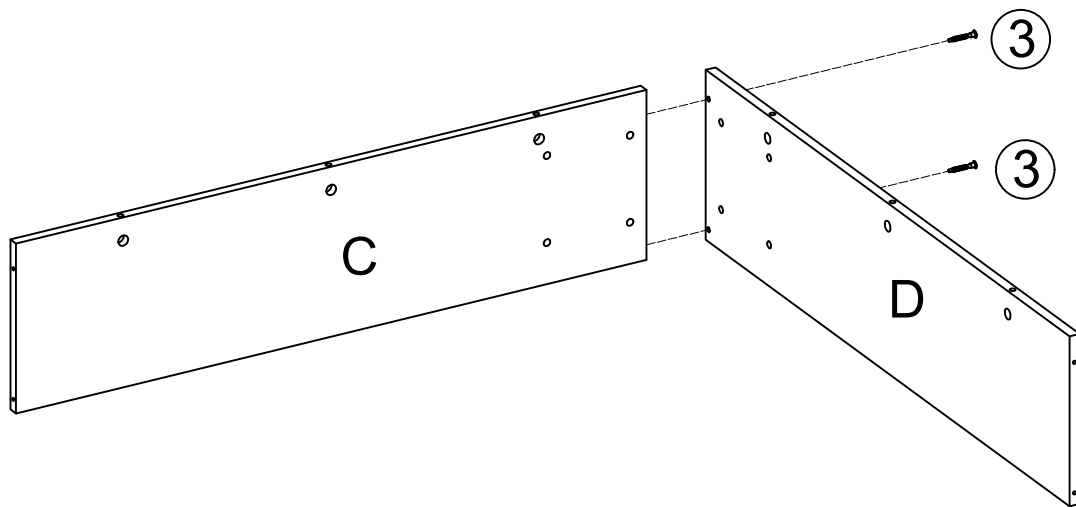

STEP 23

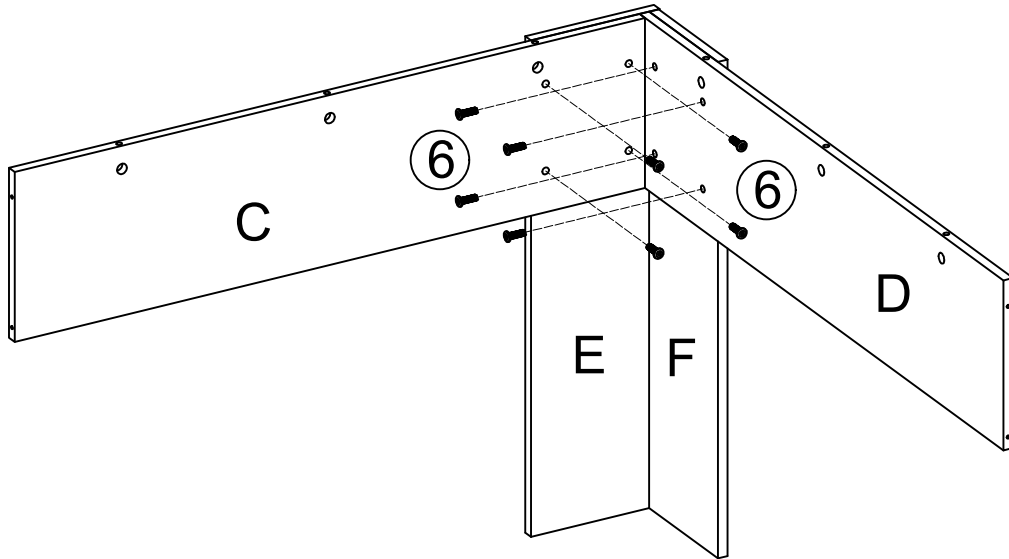
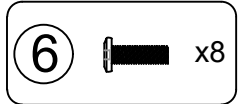

STEP 24

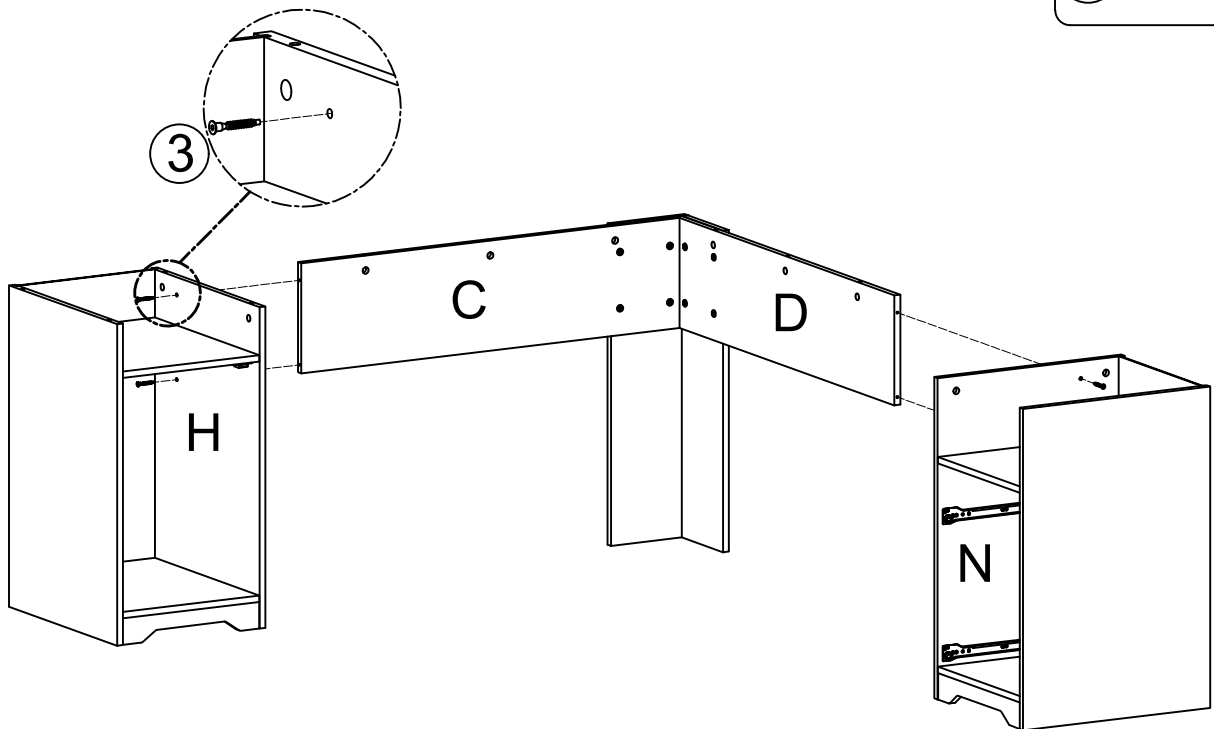

STEP 25

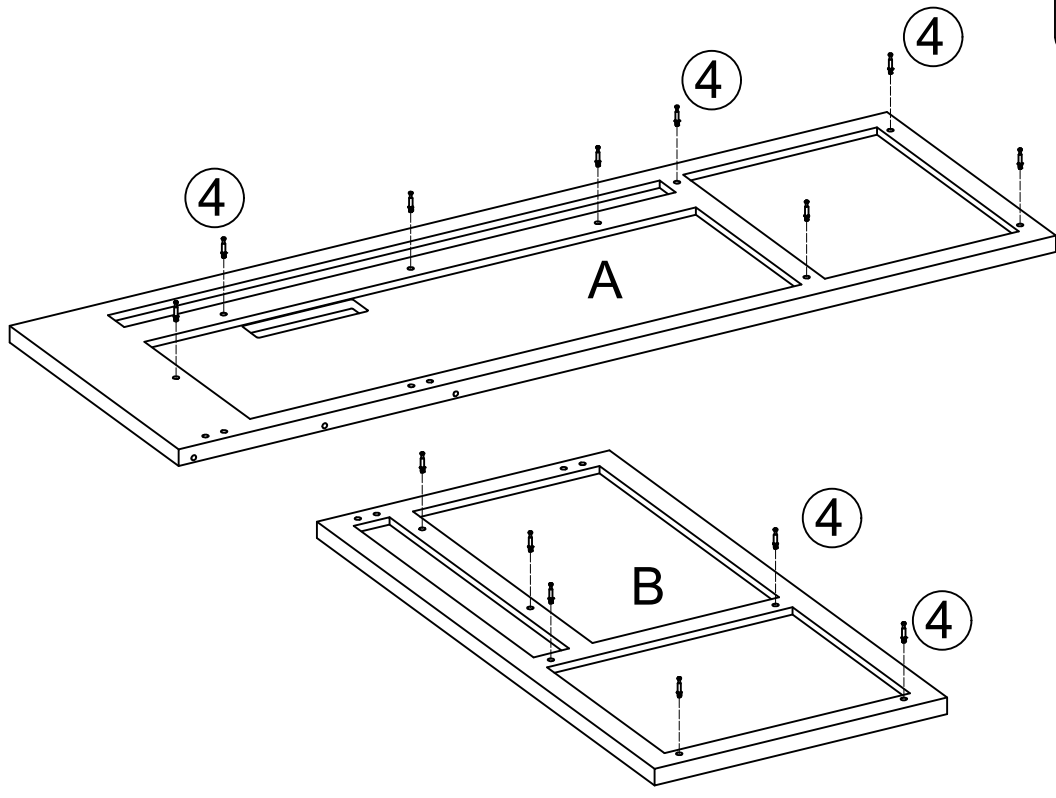
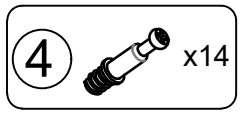

STEP 26

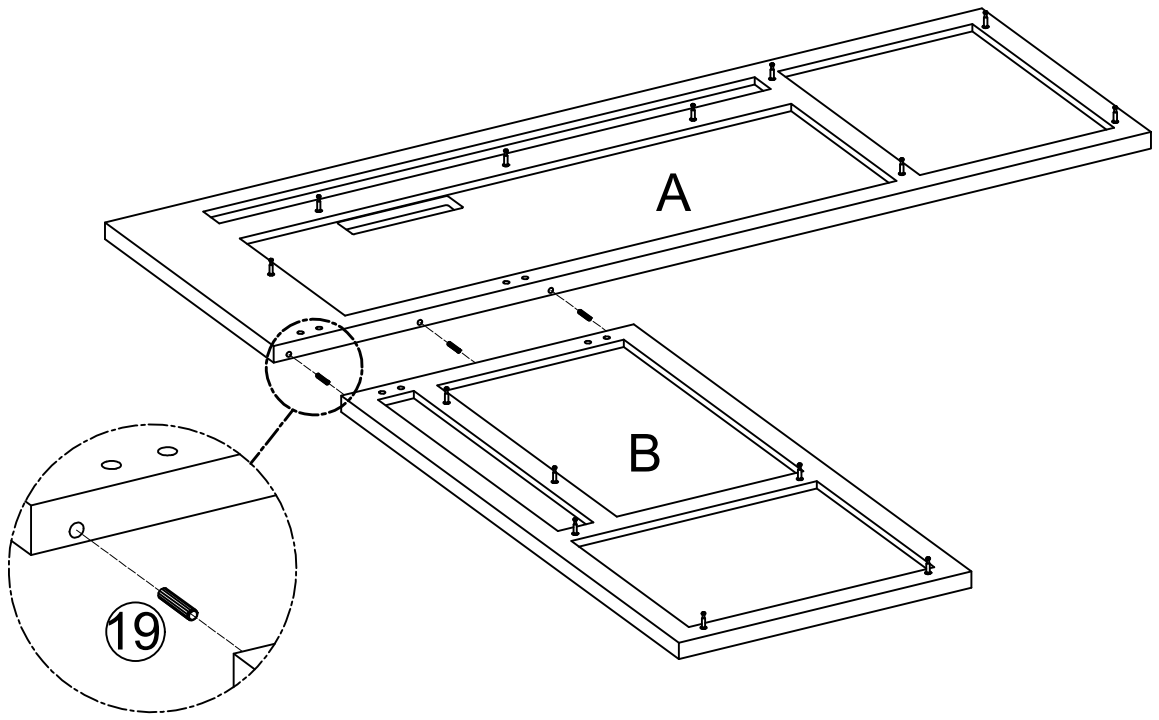
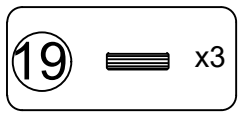

STEP 27

- 17 x8
- 18 x2

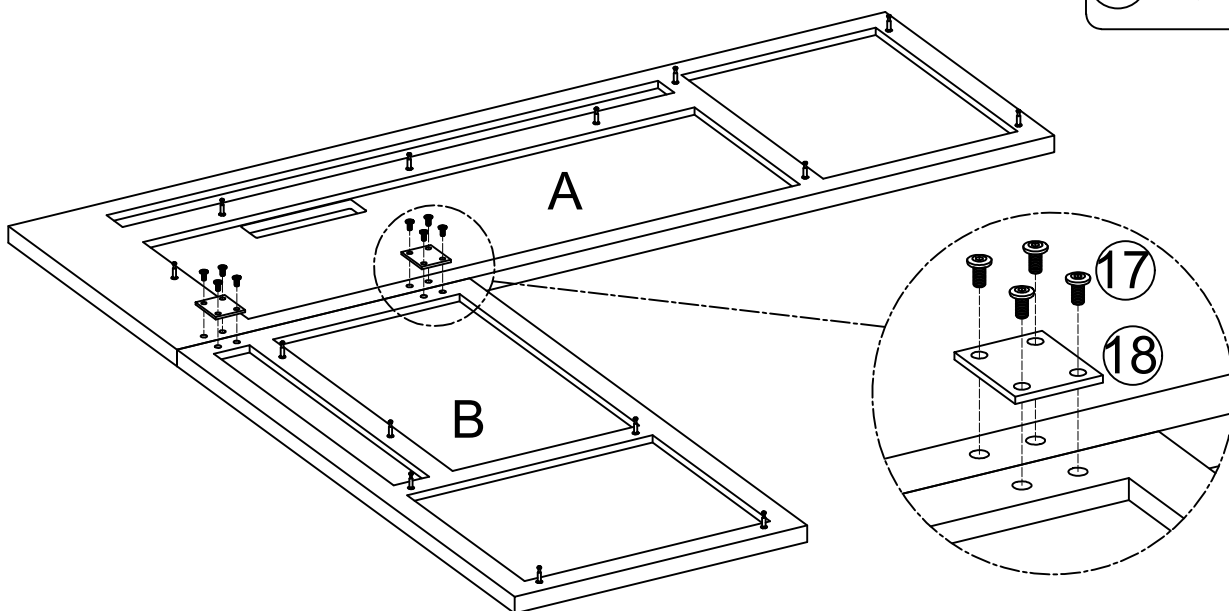



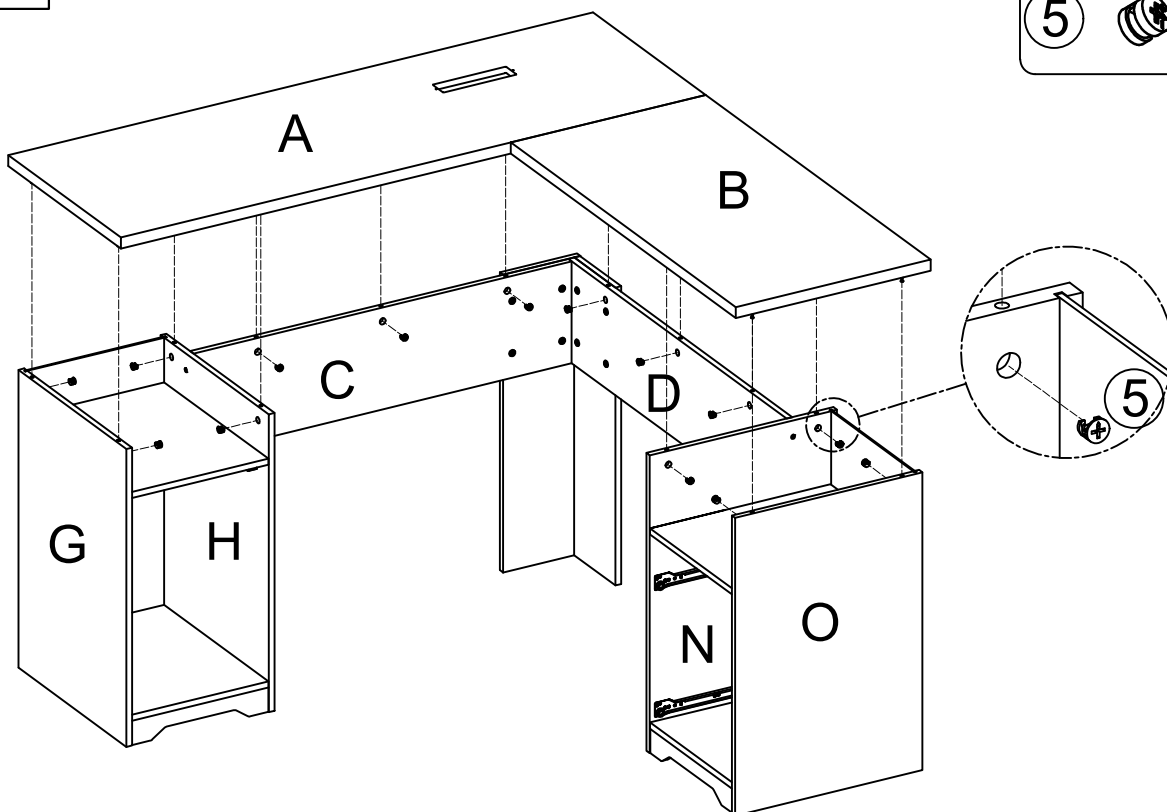

STEP 28

- 5 x14

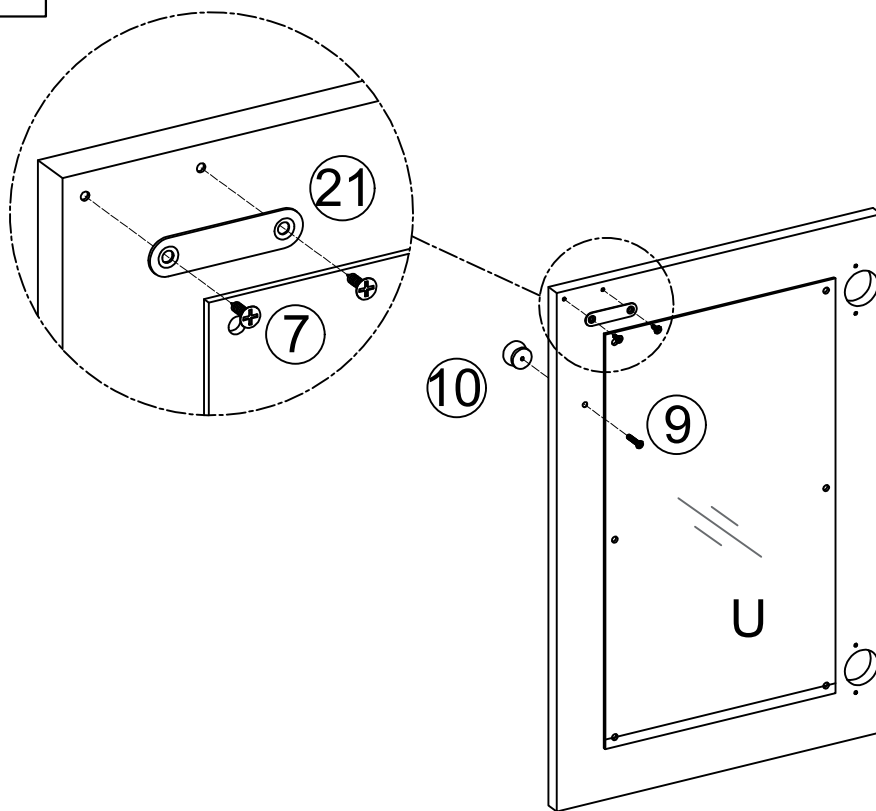



STEP 29

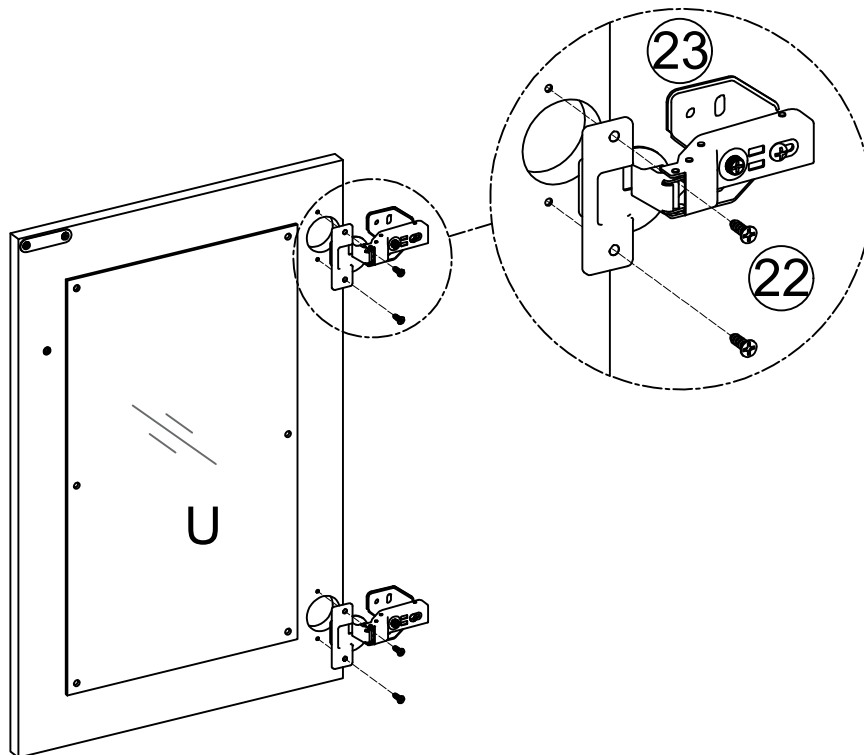

- 7**  x2
- 9**  x1
- 10**  x1
- 21**  x1

STEP 30



- 22**  x4
- 23**  x2

STEP 31

22  x8

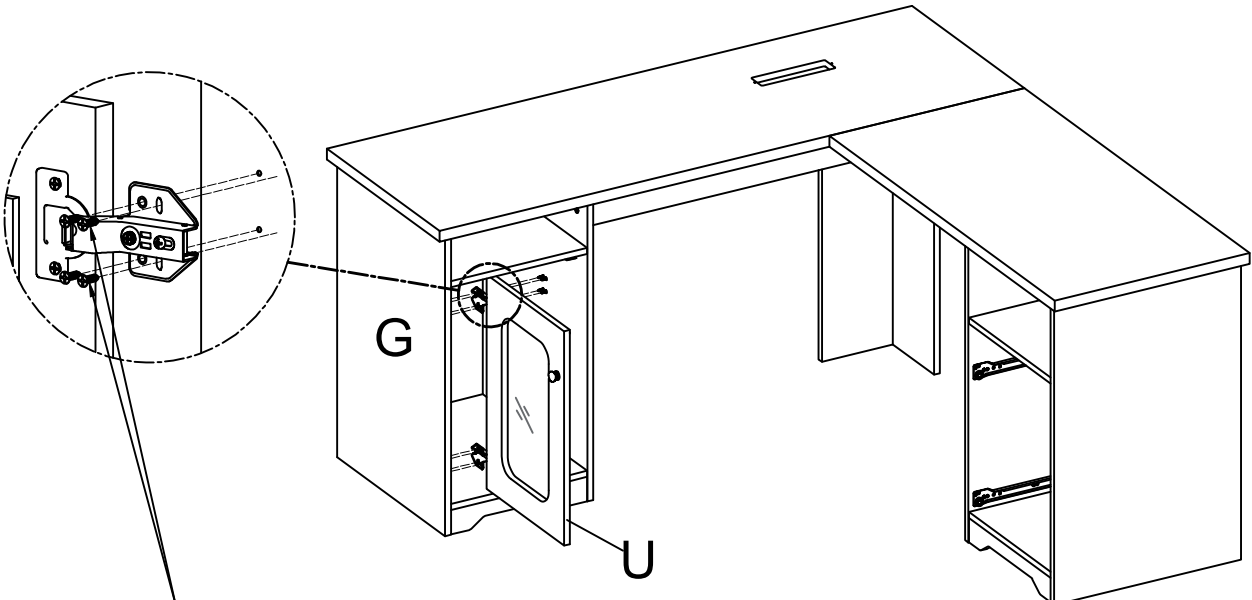

There are no reserved holes for two back screws, please use tools to screw directly.

STEP 32

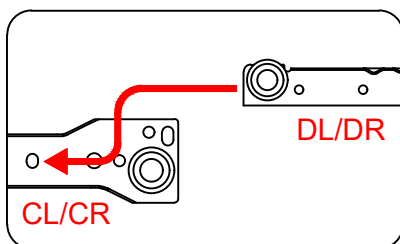
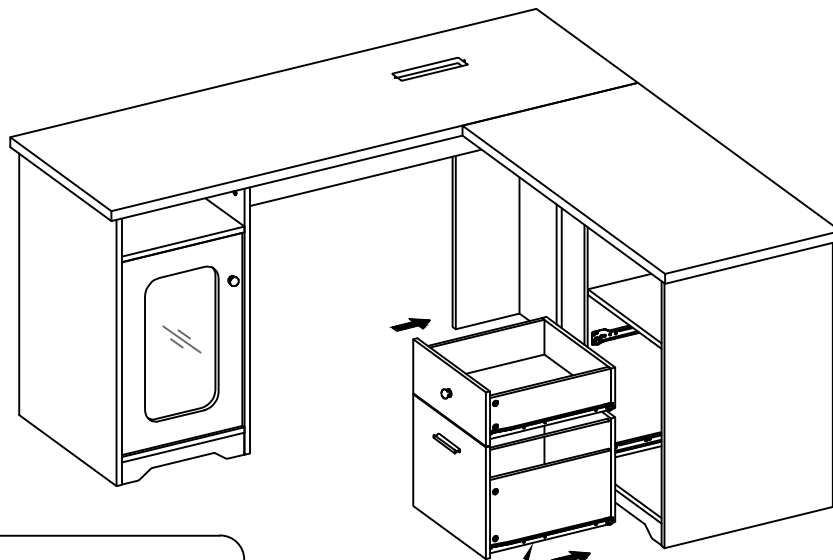

Please put the wheels align with the slots as the instruction shows, then slide into them

STEP 33

