

## NOTICE

- \* Please make sure that you have all parts indicated and they are in good condition before you begin assembly of this item. Refer to part list and hardware list below for guidance.
- \* This item should be assembled on a soft surface to prevent scratching the finish during assembly.
- \* This item may require periodic tightening.
- \* If you are having difficulty, our friendly Customer Care team is always here to help. Please email [customersupport@safavieh.com](mailto:customersupport@safavieh.com)

## PREPARATION



- \* Before beginning assembly of product, make sure all parts are present. Compare parts with part contents list and hardware contents list.
- \* If any part is missing or damaged, do not attempt to assemble the product.
- \* Estimated Assembly Time : 10 minutes.
- \* Tools required for Assembly (included) : Allen Key

## CARE AND MAINTENANCE

**WOOD CARE:** Adhesive felt pads should always be applied to areas of furniture which make direct contact with flooring, said application will prevent damage to the furniture and or surfaces on which the furniture lies. Objects placed on articles of furniture should rest on nonabrasive material as to prevent damage to the wood finish. Wipe up spills immediately and avoid common hazards such as hot dishes, harsh solvents and abrasives. Cleaning should be done with a soft lint free cotton cloth dampened with water or furniture polish.

**UPHOLSTERY CARE:** To prevent overall soiling, frequent vacuuming or light brushing is recommended. Cushions and pillows should be turned on a weekly basis. Down-filled cushions should be brushed rather than vacuumed. Spot clean should undertake a complete overall cleaning. The use of steam or water-based cleaners may cause excessive shrinking or staining.

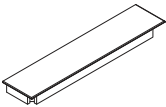
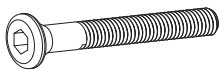
### Part List and Hardware List

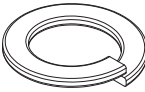
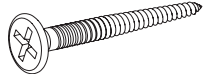
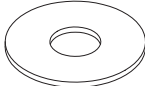
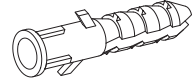
PIECE	DESCRIPTION	PICTURE	QTY	PIECE	DESCRIPTION	PICTURE	QTY	PIECE	DESCRIPTION	PICTURE	QTY
A	Table Top		1x	HW 1	Jcbb Bolt M8x0.5x60mm		4x	HW 4	Allen Key M5		1x
B	Table Leg		2x	HW 2	Spring Washer 8mm		4x	HW 5	CSK Screw M4x2.0x45mm		2x
				HW 3	Flat Washer 8mm		4x	HW 6	Wall Plug		2x



ITEM ID: CNS1400

ITEM DIMENSION: 45.27"W x 9.84"D x 35.43"H

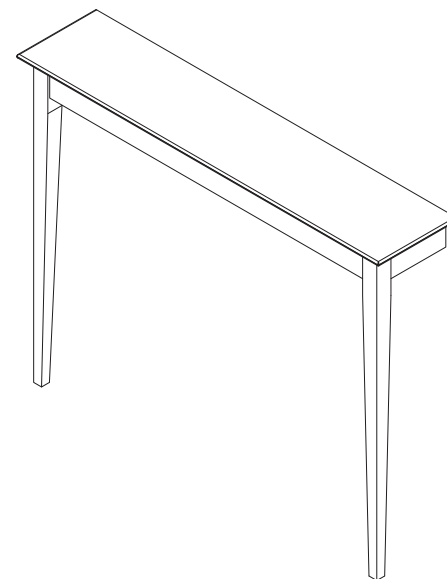

**WARNING**



Weight capacity - 165 LBS

Warning : Do not stand on table.

Warning : Do not over torque bolts.

# PREPARATION

- \* Before beginning assembly of product, make sure all parts are present. Compare parts with part contents list and hardware contents list.
- \* If any part is missing or damaged, do not attempt to assemble the product.
- \* Estimated Assembly Time : 10 minutes.
- \* Tools Required for Assembly (included) : Allen Key

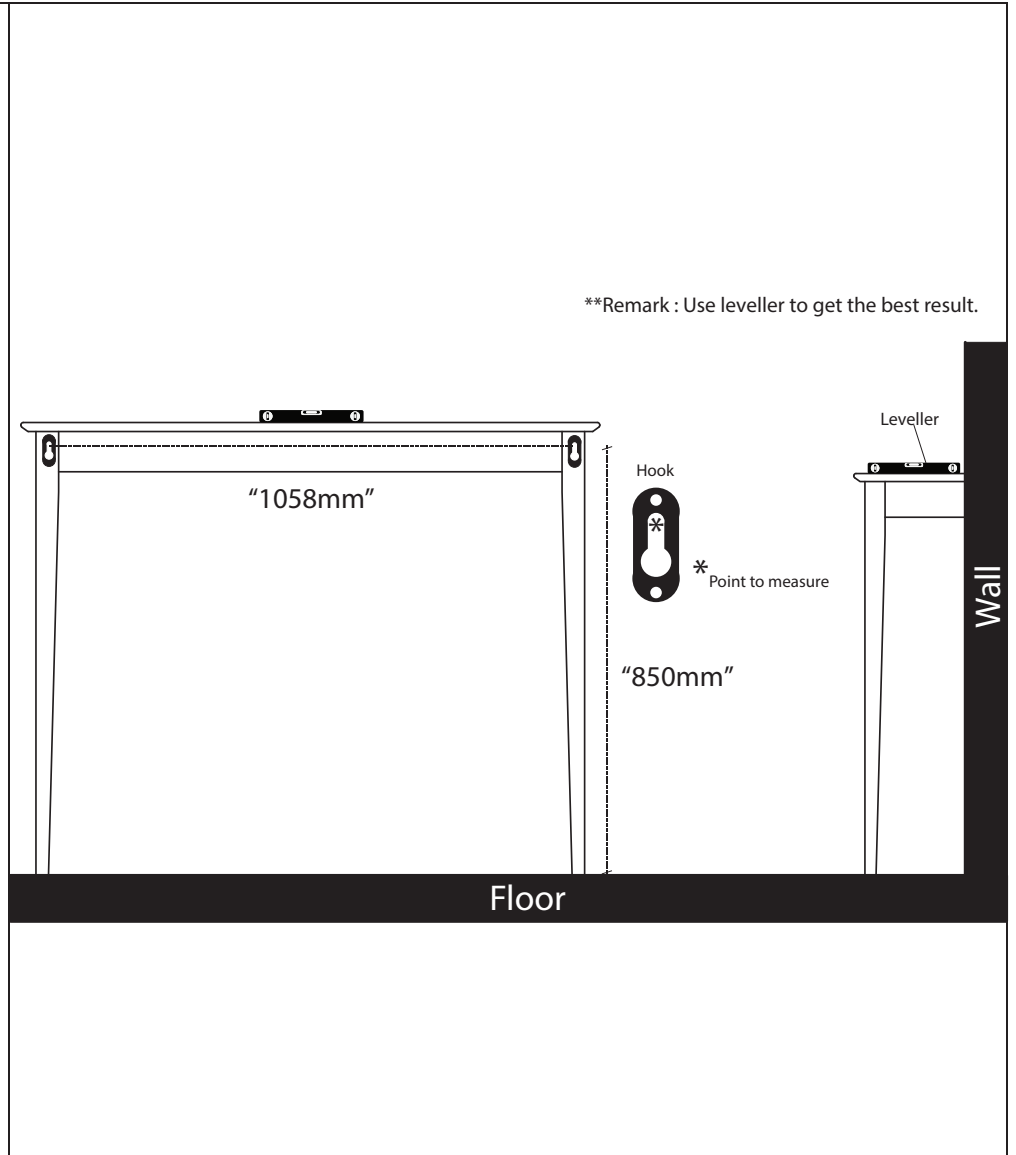
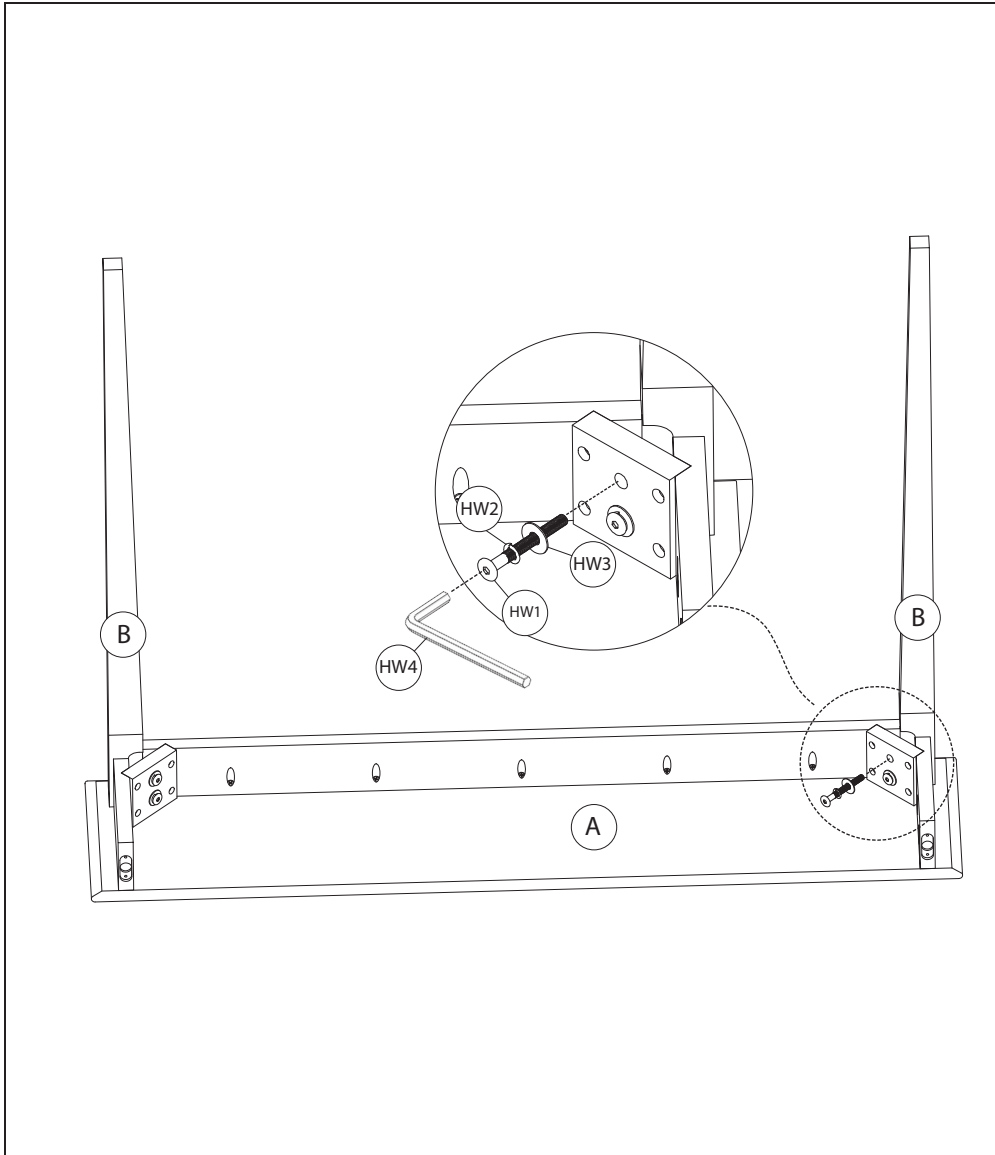

**Step 1 :** Place the table leg (B) in position and screw in the bolts (HW1). Put the washer (HW2,HW3) on the bolts (HW1) in the order shown in the picture.

**Step 2 :** Look at the back there is two hook to attach at the wall. Measure the point to point between the hook and point to floor.

# PREPARATION

- \* Before beginning assembly of product, make sure all parts are present. Compare parts with part contents list and hardware contents list.
- \* If any part is missing or damaged, do not attempt to assemble the product.
- \* Estimated Assembly Time : 10 minutes.
- \* Tools Required for Assembly (included) : Allen Key

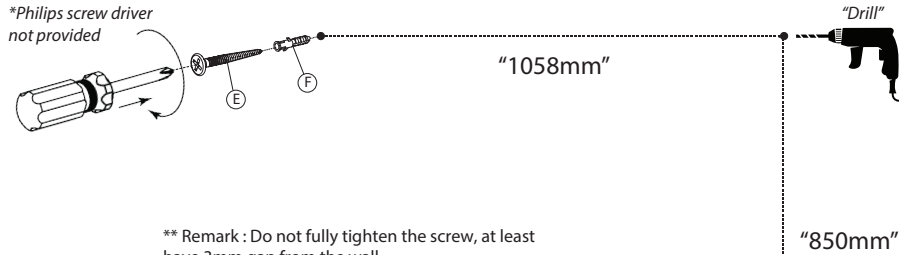
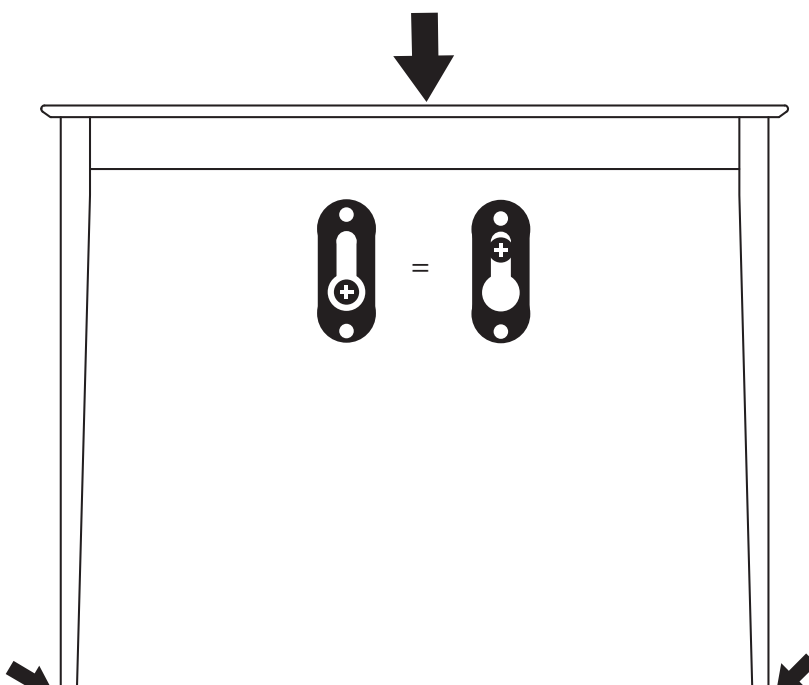
 <p>*Philips screw driver not provided</p> <p>"1058mm"</p> <p>"850mm"</p> <p>** Remark : Do not fully tighten the screw, at least have 3mm gap from the wall.</p>	
<p>Floor</p>	<p>Floor</p>
<p><b>Step 3 :</b> Measure the wall, mark it accurately. The fixing supplied are suitable for masonry wall, please use appropriate fixings for your wall construction. Always check for wires or pipes in wall before drilling. Drill and fit wall plugs (HW6) and screws (HW5).</p>	<p><b>Step 4 :</b> Insert the screw head inside the hook, then push the table top down to floor. Make sure the leg touch the floor to secure the table.</p>