









Round Dining Table

Base
Top

Examine all packaging material for small parts that may have come loose during shipment. Periodic checks are recommended to insure that all components are in proper position, tight and free from damage. Keep this assembly instruction for future reference. Adult assembly is required.

CODE	QTY	HARDWARE
1	2	1/4" x 12 Allen Bolts 
2	4	1/4" x 30 Allen Bolts 
3	4	1/4" x 18 Sunk Bolts 
4	4	1/4" x 30 Sunk Bolts 
5	6	Φ6.5*1.5 Spring Washers 
6	4	Φ20*Φ6.5*2.0 Flat Washers 
7	2	Φ16*Φ6.5*1.5 Flat Washers 
8	1	4*4 Allen Wrench 

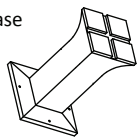
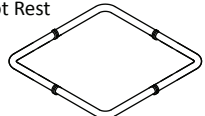
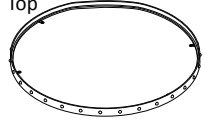
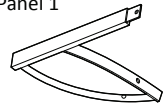
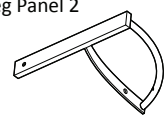
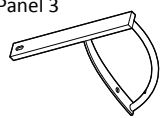
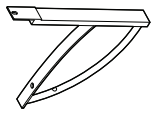
CODE	QTY	COMPONENTS	CODE	QTY	COMPONENTS
A	1	Base 	B	1	Foot Rest 
C	1	Top 	D	1	Leg Panel 1 
E	1	Leg Panel 2 	F	1	Leg Panel 3 
			G	1	Leg Panel 4 

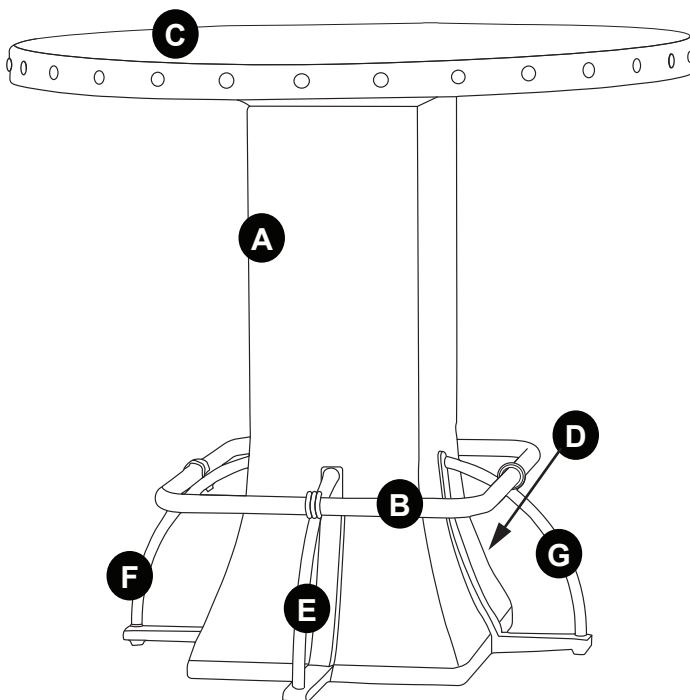

⚠ WARNING

- Do not let any sharp objects touch or rub the surface of the product.
- When assembling, do not let children play around the working area.
- Please confirm all parts are correct before starting the assembly process.
- Do not tighten all bolts and screws completely until the entire unit has been assembled and set up.
- Be careful if using power tools as they can over tighten screws and strip threads.

CARE & MAINTENANCE: The touch of a soft cloth is all the maintenance the finish will ever need. Please do not use harsh or abrasive cleaners for polishing, as they may cause damage to the finish. Periodic checks are recommended to make sure that all hardware is securely tightened.

Round Dining Table

Base
Top

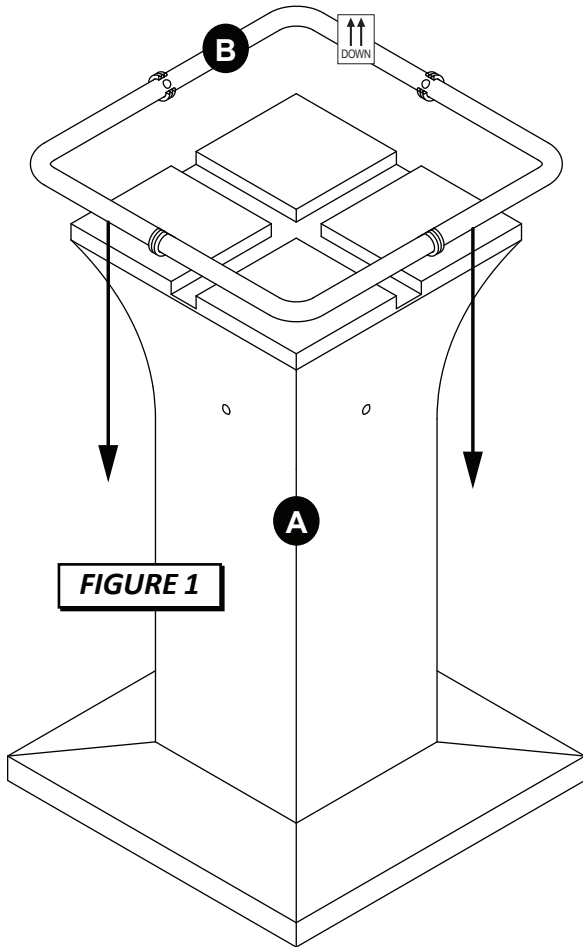

STEP 1 - Figure 1

Begin assembly by setting Base (A) upside down on a clean smooth surface. Turn Foot Rest (B) upside down and slide down on to Base (A).

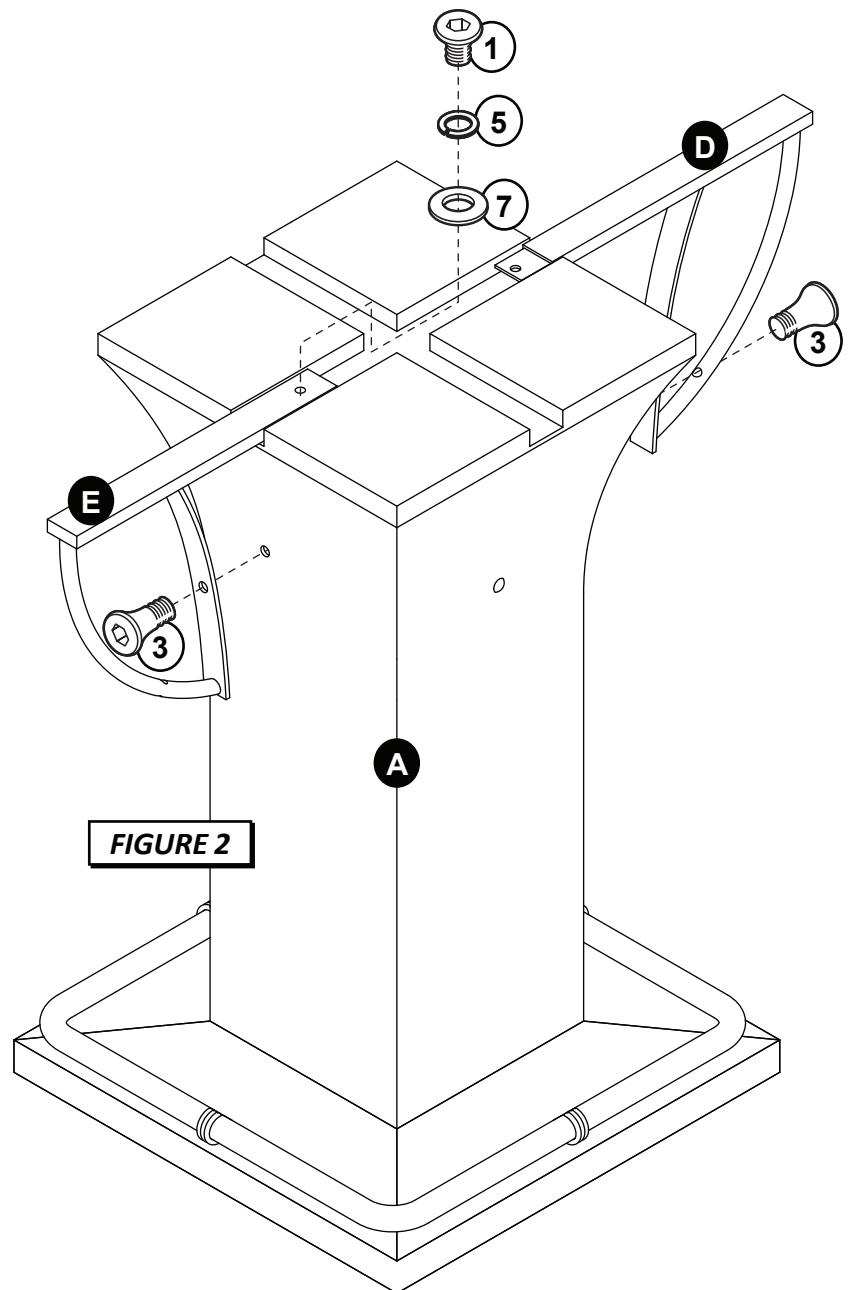

STEP 2 - Figure 2

Slide in Leg Panel 1 (D) and then Leg Panel 2 (E) over the top and then line up the holes and secure with 1 Allen Bolt (1), 1 Spring Washer (5) and 1 Flat Washer (7) from the top and 1 Sunk Bolt (3) from each side.

Base
Top

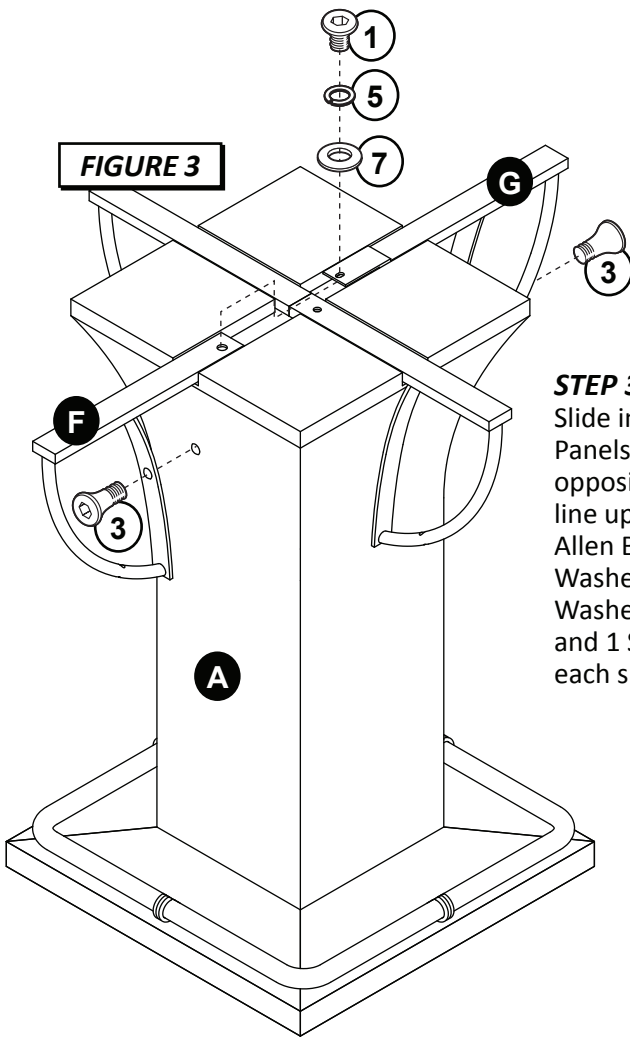

STEP 3 - Figure 3
Slide in remaining 2 Leg Panels (F & G) from opposite sides until they line up and secure with 1 Allen Bolt (1), 1 Spring Washer (5) and 1 Flat Washer (7) from the top and 1 Sunk Bolt (3) from each side.

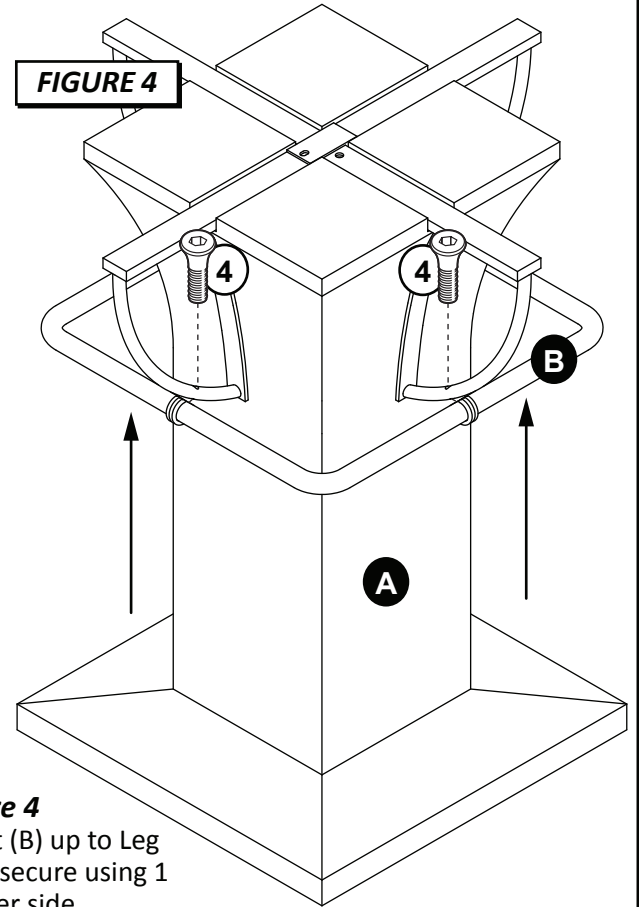

STEP 4 - Figure 4
Raise Foot Rest (B) up to Leg Panels (D) and secure using 1 Sunk Bolt (4) per side.

STEP 5 - Figure 5
Set Top (C) upside down on a clean smooth surface. Line up holes of Base (A) and Top (C) then secure each with 4 Allen Bolts (2), 4 Spring Washers (5) and 4 Flat Washers (6). Tighten all bolts with Allen Wrench (8) provided.

