

ASSEMBLY INSTRUCTION

Important note:

1. Place all wooden parts on a clean and smooth surface such as a rug or carpet to avoid scratching the parts.
2. Kindly follow the assembly instructions step by step.
3. Do not tighten all screws and bolts until the table is fully assembled.
4. Unscrew the protective plastique supports from the metal insert of the table legs before assembly.

PARTS IDENTIFICATION

A Table Top

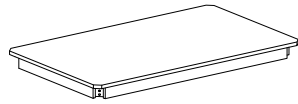

1pc

B Table Leg

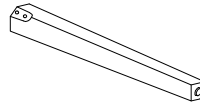

4pcs

HARDWARE IDENTIFICATION

1 Bolt

Ø5/16"x60mm



8pcs

2 Spring Washer

Ø5/16"x13mm



8pcs

3 Flat Washer

Ø5/16"x19mm



8pcs

4 Allen Key



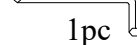

M4

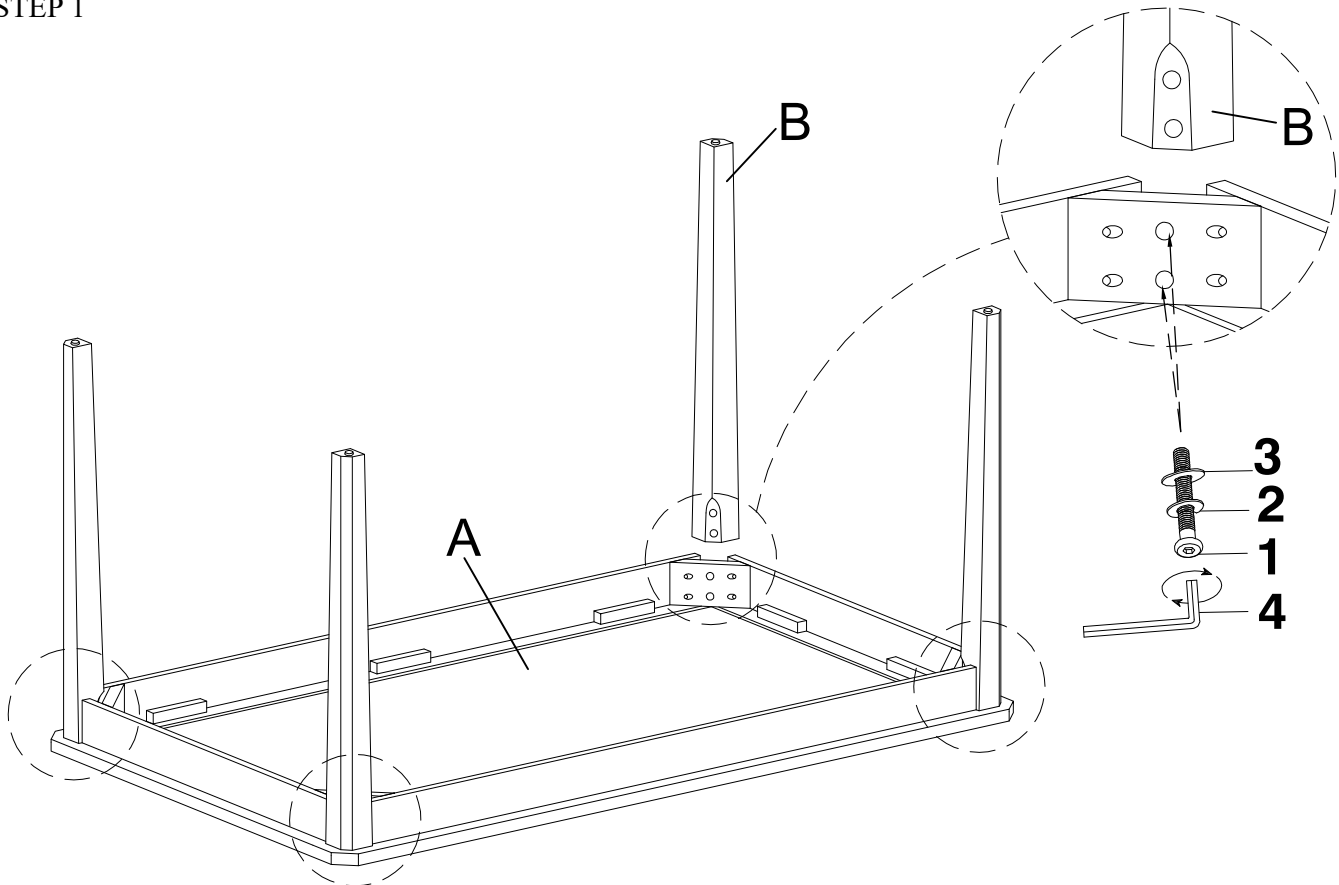

1pc

STEP 1



1 	Bolt	2 	Spring Washer	3 	Flat Washer	4 	Allen Key
Ø5/16"x60mm	8pcs	Ø5/16"x13mm	8pcs	Ø5/16"x19mm	8pcs	M4	1pcs

ASSEMBLY INSTRUCTION

COMPLETE

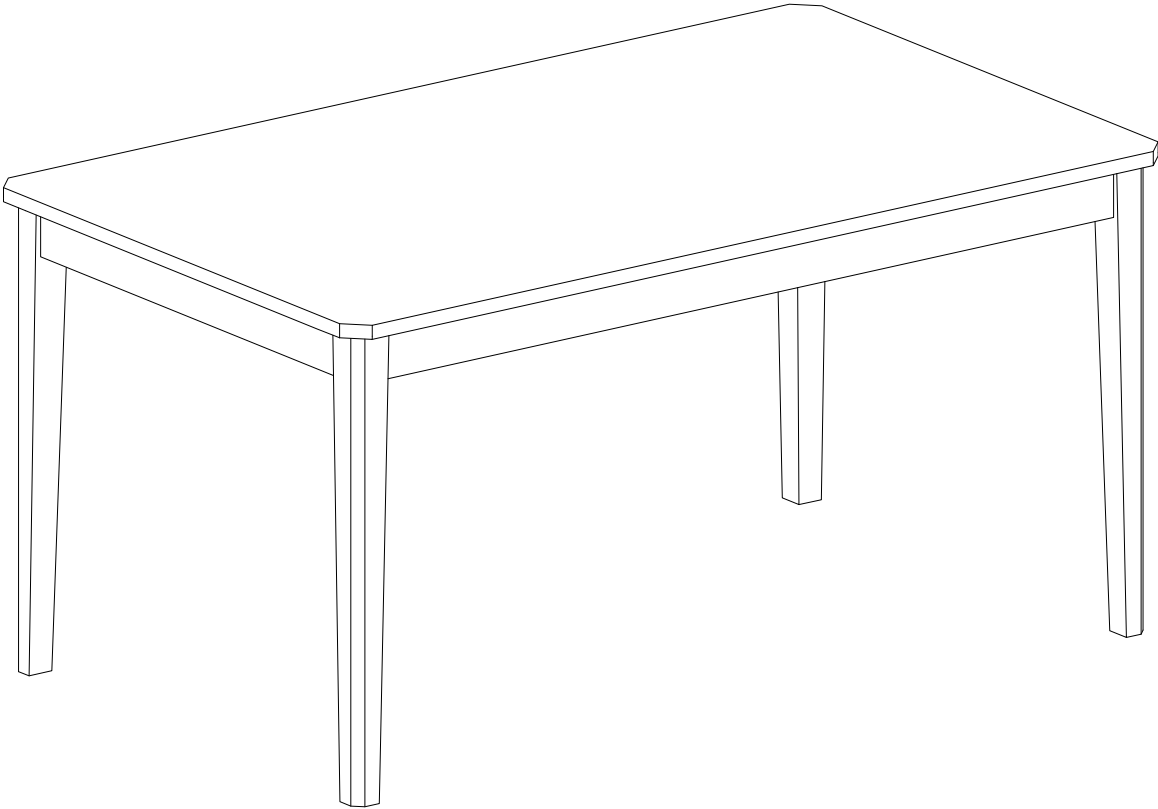

ASSEMBLY INSTRUCTION

Important note:

1. Place all wooden parts on a clean and smooth surface such as a rug or carpet to avoid scratching the parts.
2. Kindly follow the assembly instructions step by step.
3. Do not tighten all screws and bolts until the table is fully assembled.
4. Unscrew the protective plastique supports from the metal insert of the legs before assembly.

PARTS IDENTIFICATION

A Chair Back

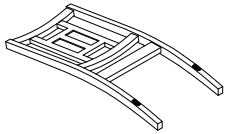

1pc

B Seat cushion

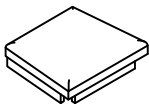

1pc

C Left Leg

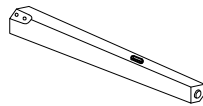

1pc

D Right Leg

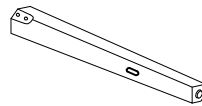

1pc

E Side Strecher

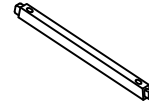

1pc

F Side Strecher

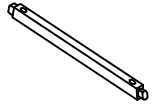

1pc

HARDWARE IDENTIFICATION

1 Long Bolt

Ø1/4"x75mm



4pcs

2 Bolt

Ø1/4"x50mm



4pcs

3 Bolt

Ø1/4"x38mm



2pcs

4 Spring Washer

Ø1/4"x11mm



10pcs

5 Flat Washer

Ø1/4"x19mm



10pcs

6 Allen Key

M4

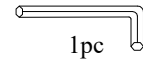

1pc

7 Wood screw



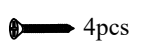

#8x38mm

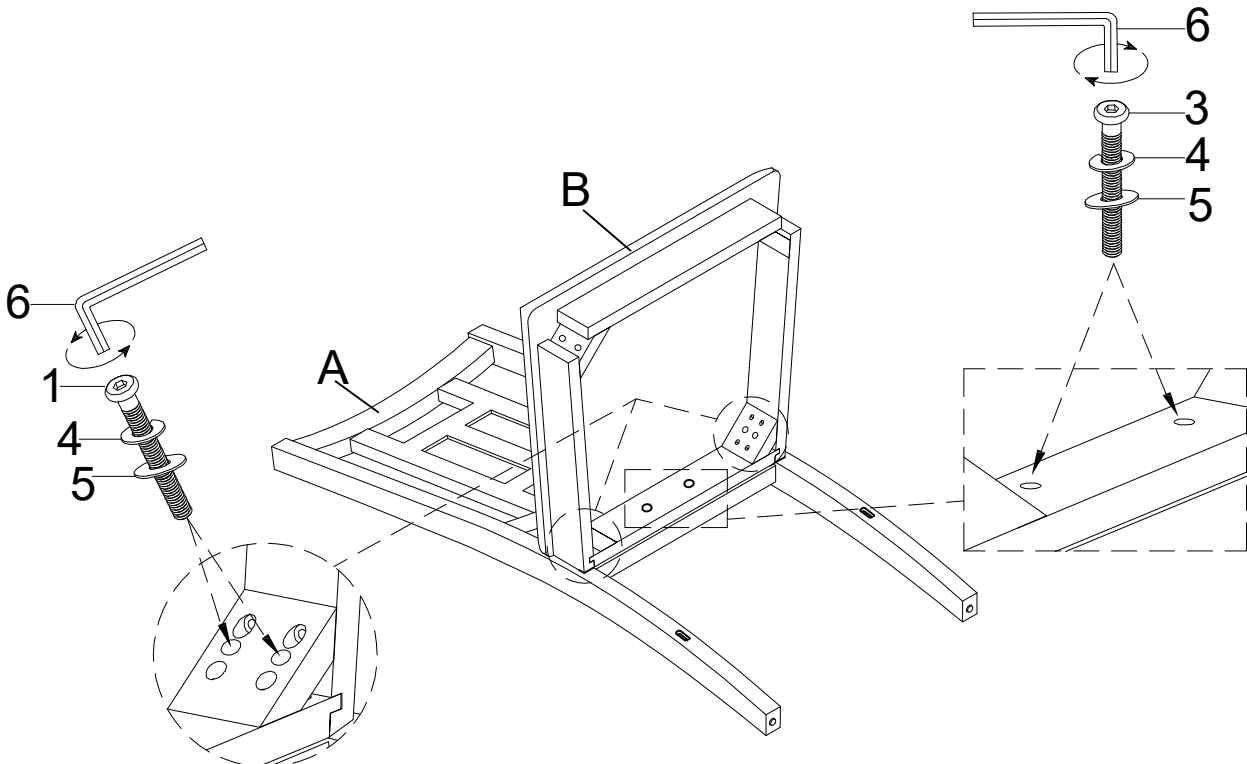

4pcs

STEP 1





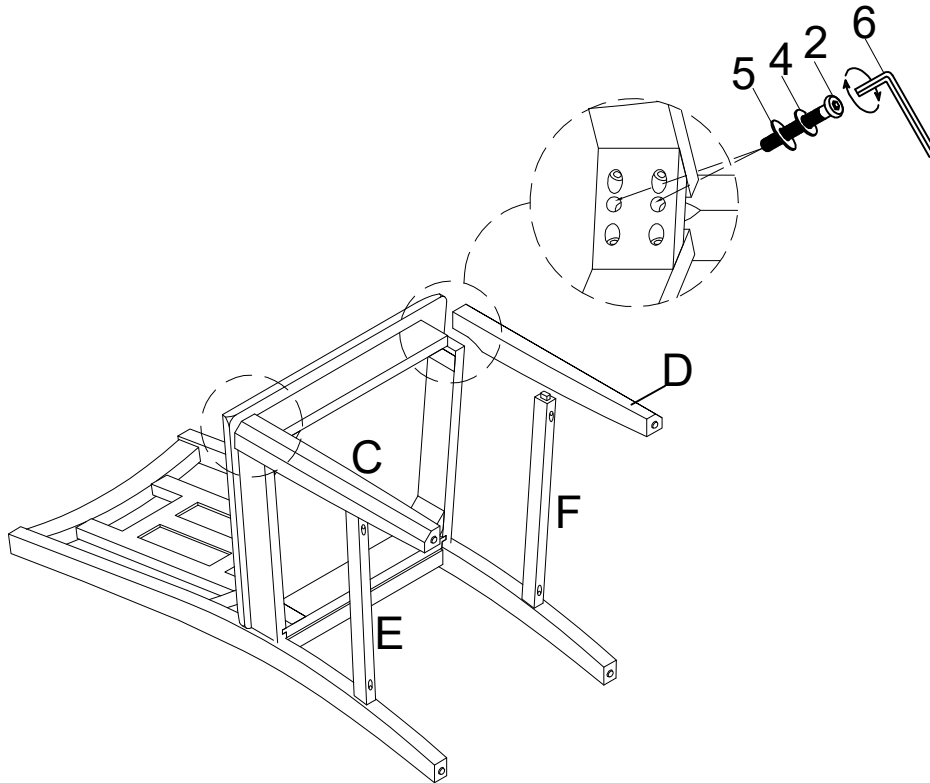

1 	Long Bolt	3 	Bolt	4 	Spring Washer	5 	Flat Washer	6 	Allen Key
Ø1/4"x75mm	4pcs	Ø1/4"x38mm	2pcs	Ø1/4"x11mm	6pcs	Ø1/4"x19mm	6pcs	M4	1pcs

ASSEMBLY INSTRUCTION

STEP 2



2  Ø1/4"x50mm	Bolt	4  Ø1/4"x11mm	Spring Washer	5  Ø1/4"x19mm	Flat Washer	6  M4	Allen Key
	4pcs		4pcs		4pcs		1pcs

STEP 3

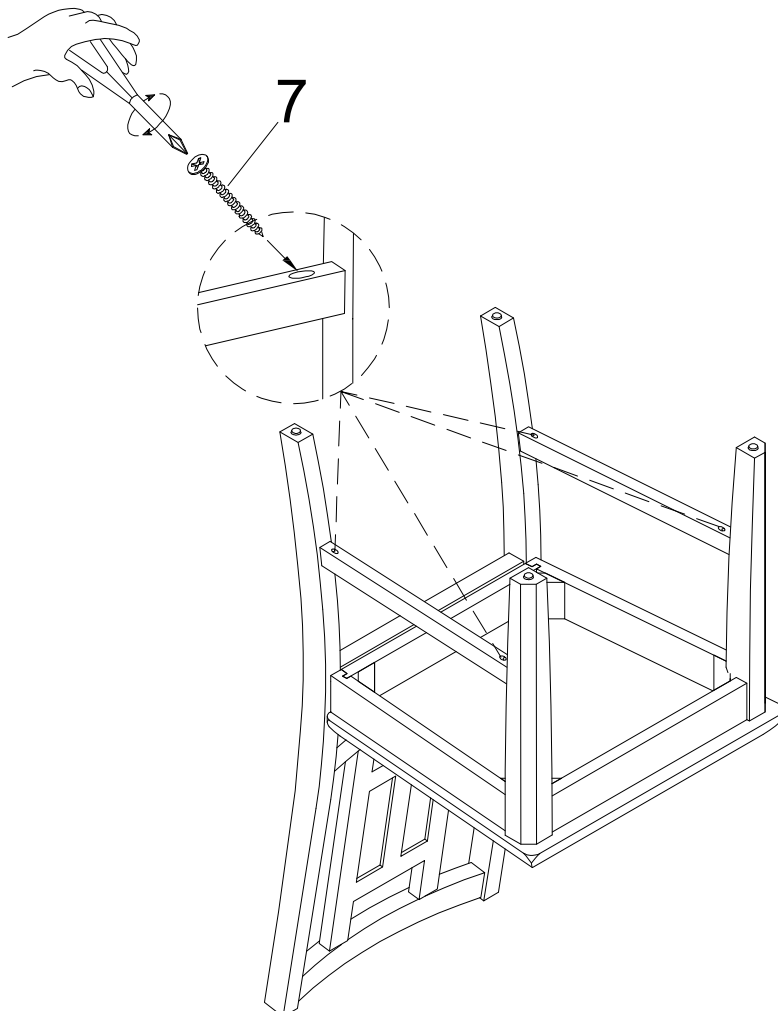

7  #8x38mm	Wood screw
	4pcs

ASSEMBLY INSTRUCTION

COMPLETE

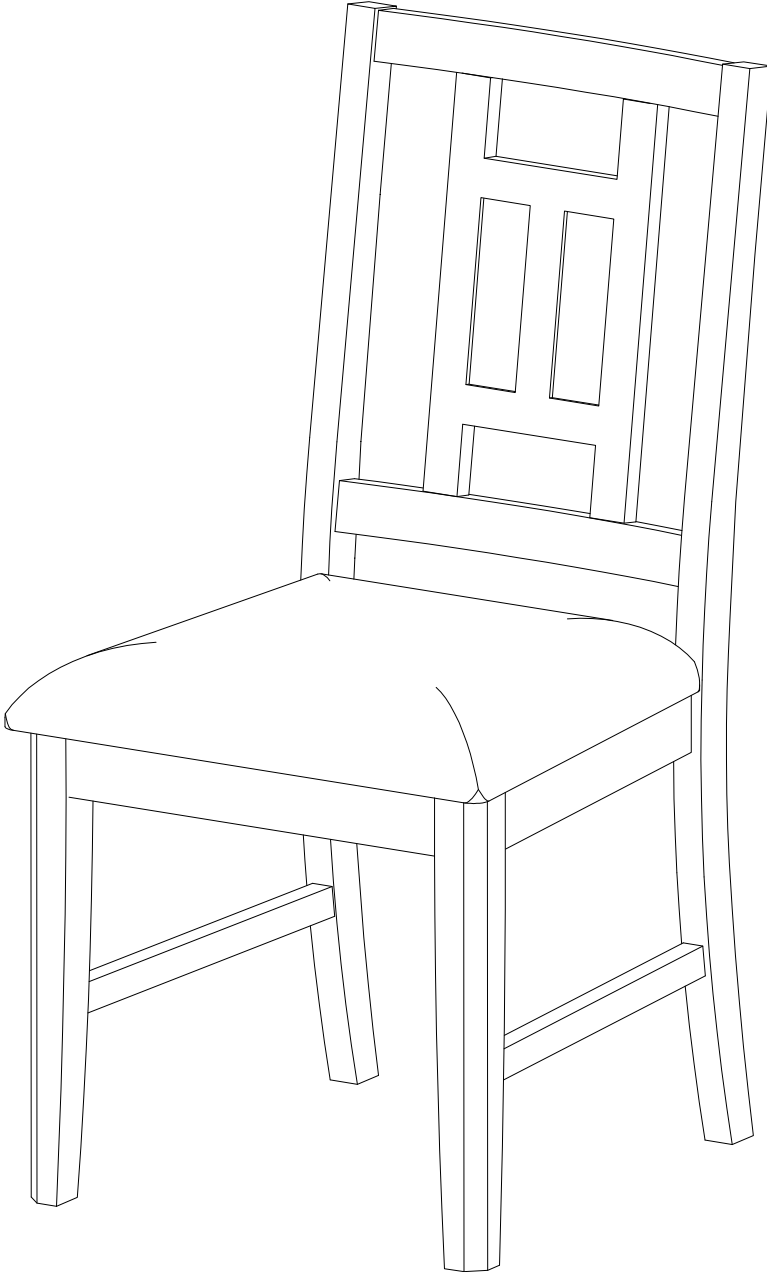

ASSEMBLY INSTRUCTION

Important note:

1. Place all wooden parts on a clean and smooth surface such as a rug or carpet to avoid scratching the parts.
2. Kindly follow the assembly instructions step by step.
3. Do not tighten all screws and bolts until the table is fully assembled.
4. Unscrew the protective plastique supports from the metal insert of the table legs before assembly.

PARTS IDENTIFICATION

A Seat Cushion

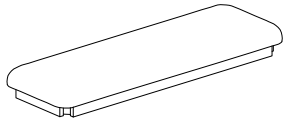

1pc

B Sheft

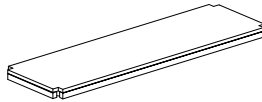

1pc

C Leg

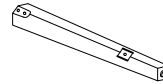

4pcs

HARDWARE IDENTIFICATION

1 Bolt

Ø1/4"x50mm



12pcs

2 Spring Washer

Ø1/4"x11mm



12pcs

3 Flat Washer

Ø1/4"x19mm



12pcs

4 Allen Key



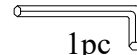

M4

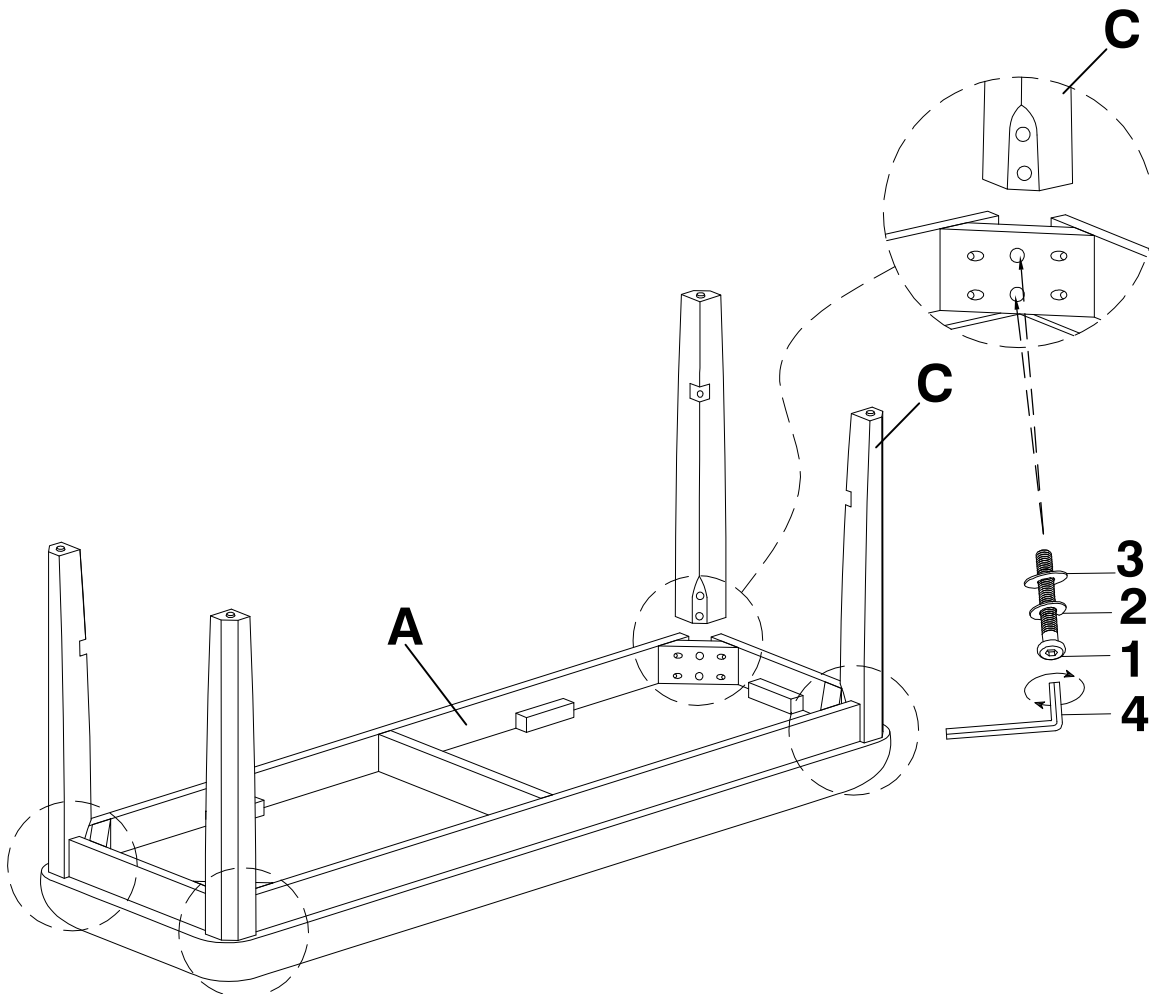

1pc

STEP 1





1 	Bolt	2 	Spring Washer	3 	Flat Washer	4 	Allen Key
Ø1/4"x50mm	8pcs	Ø1/4"x11mm	8pcs	Ø1/4"x19mm	8pcs	M4	1pcs

ASSEMBLY INSTRUCTION

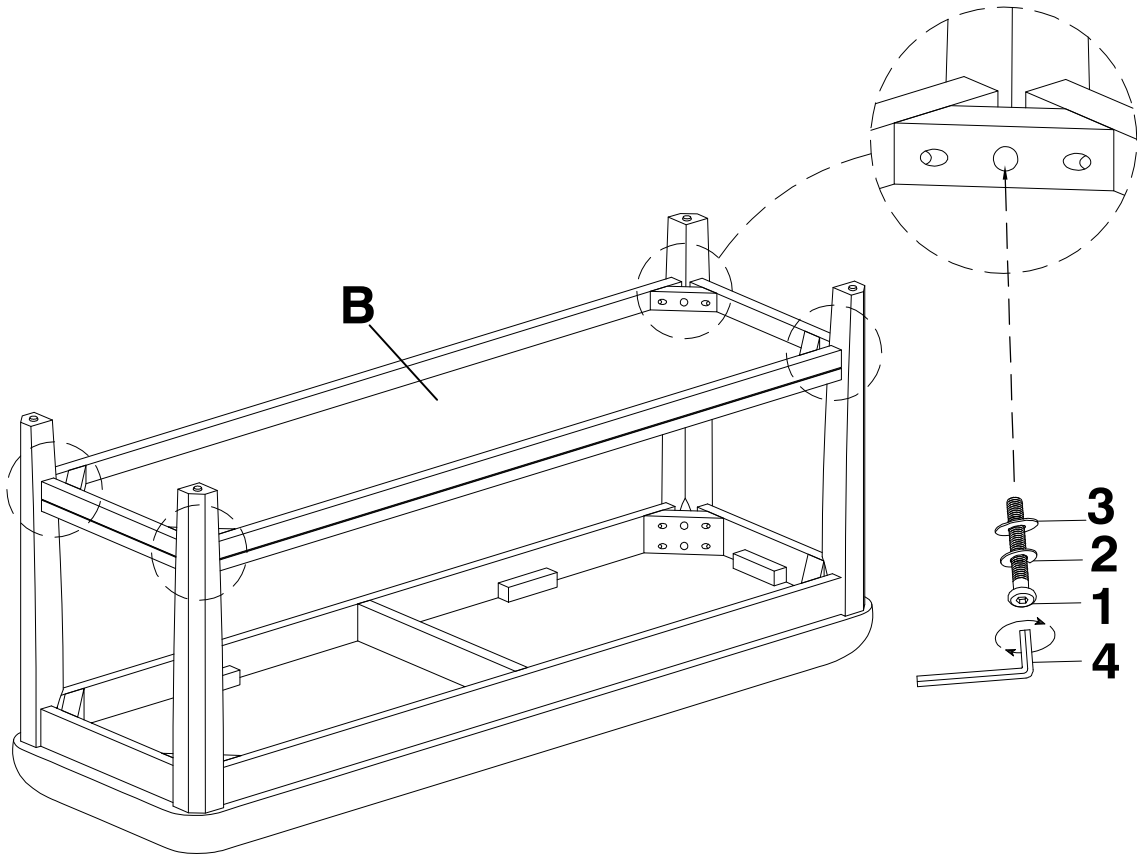
STEP 2





1		Bolt
	Ø1/4"x50mm	4pcs

2		Spring Washer
	Ø1/4"x11mm	4pcs

3		Flat Washer
	Ø1/4"x19mm	4pcs

4		Allen Key
	M4	1pcs

1		Nut
	Ø1/4"x11mm	4pcs

2		Spring Washer
	Ø1/4"x11mm	4pcs

3		Flat Washer
	Ø1/4"x19mm	4pcs

4		Allen Key
	M4	1pcs

COMPLETE

