

ASSEMBLY AND INSTALLATION INSTRUCTIONS

WARNING: TO AVOID RISK OF ELECTRICAL SHOCK, BE SURE TO SHUT OFF POWER WHILE INSTALLING OR SERVICING THIS FIXTURE.

NOTES:

1. Before installing, consult local electrical codes for wiring and grounding requirements.
2. Read and save these instructions.
3. Always switch off the electricity supply and allow to cool for 10 minutes before changing the light bulbs.

2-LIGHT OUTDOOR WALL SCONCE

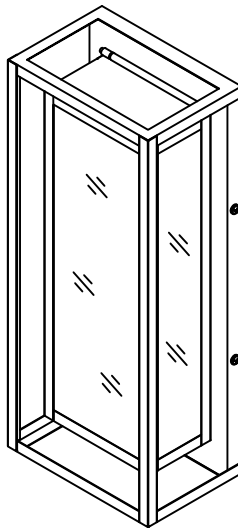

TOOLS REQUIRED

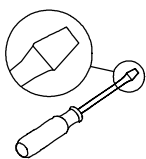

Flathead
Screwdriver

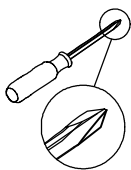

Phillips
Screwdriver



Ladder

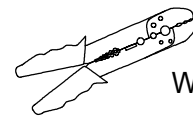

Wire Strippers



Pliers



Electrical
Tape

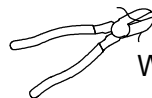

Wire Cutters



Safety Glasses

PREPARATION

Before beginning assembly of product, make sure all parts are present. Compare parts with package contents list and hardware contents list. If any part is missing or damaged, do not attempt to assemble the product. When the lamp is not installed finish, please don't throw away the package, so as not to leave the parts in the package.

PART LIST AND HARDWARE LIST

PIECE	DESCRIPTION	QUANTITY
A	Wire nut	3
B	Strain relief bushing	2
C	Mounting plate	1
D	Green ground screw	1
E	Wooden screw	2
F	Outlet box screw	2
G	Rubber Pad	4
H	Mounting screw	4
I	Fixture body	1
J	Decorative Nut	1

INSTALLATION

1. Fix the mounting plate(C) to the outlet box with outlet box screws(F), then fix the self-wooden screw(E) in the Strain relief bushing(B).
2. Connect the power circuit grounding wire (green or bare copper wire) to the fixture grounding wire, Black to (black) and white to (white).
3. Use Rubber Pads (G) mounting screws (H) to connect the fixture body (I) to the mounting plate (C).
4. Unscrew the decorative nut (J) and open the small frame on the clamp (I) (as shown in the figure).
5. Install two B-type bulb with a maximum power of 40W (not included) onto the lamp head.
6. Close the small frame on the Fixture body (I) and tighten it with decorative nuts(J).

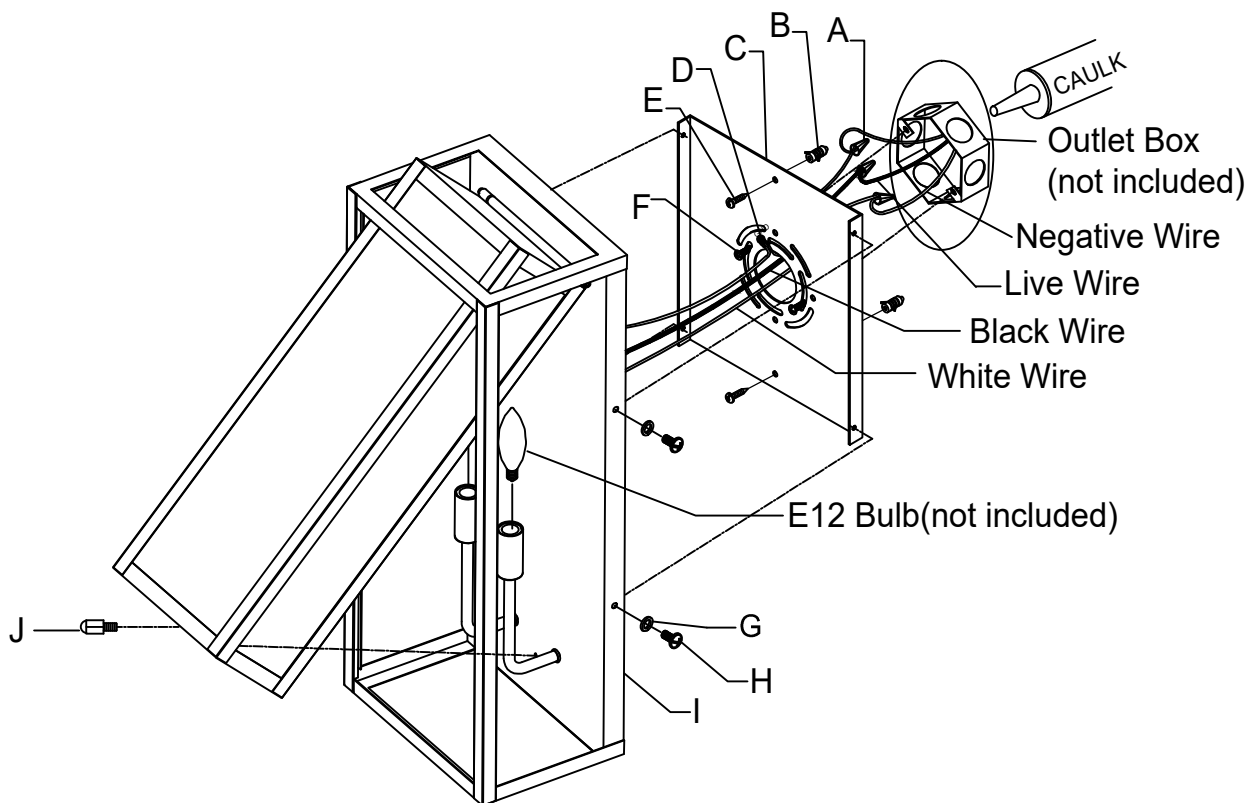

If you have any issues with use this product, please email us. Be sure to include your order number and photos of the issues. This will help us provide you with faster support and solve your problem.